

1

BASIC PHYSIOLOGY AND BIOPHYSICS OF EMG SIGNAL GENERATION

T. Moritani

*Laboratory of Applied Physiology
The Graduate School of Human and Environmental Studies
Kyoto University, Kyoto, Japan*

D. Stegeman

*Department of Clinical Neurophysiology
University Medical Center, Nijmegen
Interuniversity Institute for Fundamental and Clinical Human Movement Sciences (IFKB)
Amsterdam, Nijmegen, The Netherlands*

R. Merletti

*Laboratory for Engineering of the Neuromuscular System
Department of Electronics
Politecnico di Torino, Italy*

1.1 INTRODUCTION

Understanding EMG signals implies the understanding of muscles and the way they generate bioelectrical signals. It also implies the understanding of the “forward problem,” that is, how specific mechanisms and phenomena influence the signals, as well as the more difficult “inverse problem”, that is, how the signals reflect certain mechanisms and phenomena and allow their identification and description. The concept of forward and inverse problem is familiar to physiologists and engineers and is strictly associated to the concept

Electromyography: Physiology, Engineering, and Noninvasive Applications, edited by Roberto Merletti and Philip Parker.

ISBN 0-471-67580-6 Copyright © 2004 Institute for Electrical and Electronics Engineers, Inc.

of a system as a set of inputs, transfer functions and outputs, and of a model, as a set of descriptions and relations associating, under certain conditions and assumptions, the inputs to the outputs.

In this chapter we provide a basic description of the physiological system whose output is the needle or surface detected EMG signal. We summarize the large number of factors and phenomena that contribute to such signals and provide a basis of knowledge for the signal analysis approaches that will be addressed in the subsequent chapters. In Section 1.2 we introduce basic concepts and mechanisms of muscle physiology and motor control. In Section 1.3 we consider the basic electrophysiology of the muscle membrane. We assume that some of the concepts described in Section 1.2 (action potential, power spectrum, etc.) are known to the reader. They are discussed in greater detail in Section 1.3 and in other chapters of this book.

1.2 BASIC PHYSIOLOGY OF MOTOR CONTROL AND MUSCLE CONTRACTION

1.2.1 Motor Unit

The human motor system must cope with a great diversity of internal and external demands and constraints. These include the regulation of force output for precise and powerful movements, upright posture, locomotion, and even our repertoire of gestures. As it is impossible to describe all the specific control features of the various motor systems in isolation, we will attempt to delineate the basic principles of motor control, with special attention to the skeletomotor system, which plays the major role in the control of force and movements in humans.

Simplified schematic diagrams of the central motor system and the concept of the motor unit (MU) are presented in Figure 1.1). The central nervous system is organized in a hierarchical fashion. Motor programming takes place in the premotor cortex, the supplementary motor area, and other associated areas of the cortex. Inputs from these areas, from the cerebellum and, to some extent, from the basal ganglia converge to the primary motor cortex and excite or inhibit the various neurons of the primary motor cortex. The outputs from the primary motor cortex have a powerful influence on interneurons and motoneurons of the brain stem and of the spinal cord. There exists a link between the corticospinal tract and alpha (α)-motoneurons, providing direct cortical control of muscle activity, as indicated in Figure 1.1.

A motor unit (MU) consists of an α -motoneuron in the spinal cord and the muscle fibers it innervates (Fig. 1.1). The α -motoneuron is the final point of summation for all the descending and reflex input. The net membrane current induced in this motoneuron by the various synaptic innervation sites determines the discharge (firing) pattern of the motor unit and thus the activity of the MU. The number of MUs per muscle in humans may range from about 100 for a small hand muscle to 1000 or more for large limb muscles [33]. It has also been shown that different MUs vary greatly in force generating capacity, with a 100-fold or more difference in twitch force [27,97].

The wide variation in the morphological and electrophysiological properties of the individual motoneurons comprising a motoneuron pool is matched by an equally wide range in the physiological properties of the muscle units they innervate. Interestingly the muscle fibers that are innervated by a particular motoneuron manifest nearly identical bio-

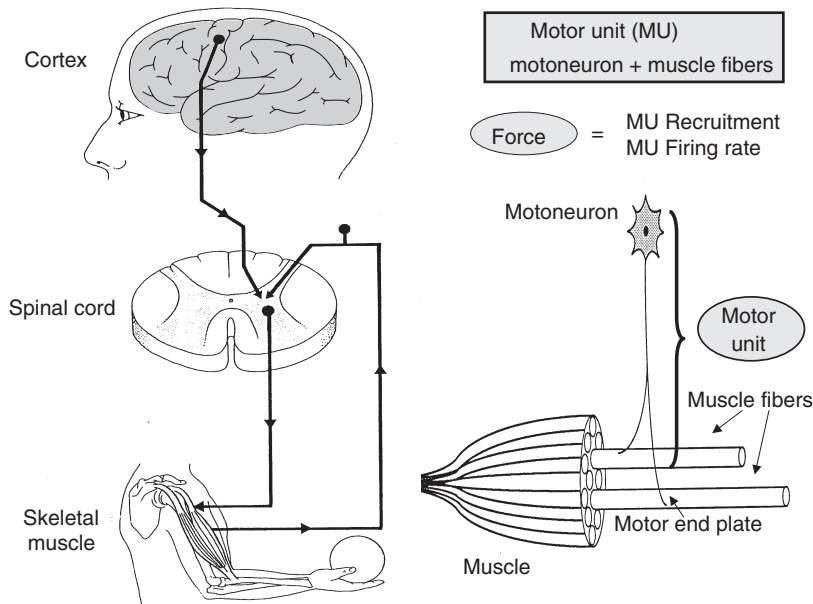

Figure 1.1. A schematic representation of basic motor control mechanisms and of the motor unit and its components. (Modified from [93] with permission)

chemical, histochemical, and contractile characteristics, together defining the typing of the specific MU. Earlier studies [10] identified three types of motor units based on physiological properties such as speed of contraction and fatigability (sensitivity to fatigue): (1) fast-twitch, fatigable (FF or type IIb); (2) fast-twitch, fatigue-resistant (FR or type IIa); and (3) slow-twitch (S or type I), which is most resistant to fatigue. The FF type motor units are predominantly found in pale muscles (high ATPase enzyme for anaerobic energy utilization), low capillarization, less hemoglobin, myoglobin, and mitochondria for oxidative energy supply), while red muscles (low ATPase, high capillarization, abundant hemoglobin, myoglobin and mitochondria for oxidative energy supply) such as the soleus are predominantly composed of type S motor units.

Figure 1.2 shows typical contractile properties of predominantly fast-twitch (extensor digitorum longus, EDL) and slow-twitch (soleus, SOL) fibers obtained from an isolated rat muscle. Note the large differences in contractile force, contraction time (CT), electromechanical delay time (EMD), and maximal rate of force development (dF/dt) and relaxation.

In humans a classification of motor units based on their physiological properties is difficult to achieve. Therefore an identification of muscle fiber populations in the muscle cross section based on histochemical criteria has been commonly adopted after obtaining a small sample of muscle tissue by a needle biopsy technique. Type I muscle fibers have high levels of ATPase activity and low levels of succinic dehydrogenase (SDH, one of the major enzymes for aerobic energy production), and type II fibers demonstrate the reverse pattern of enzyme activity. Type II fibers are subdivided in two subgroups type IIa and type IIb with different properties. Figure 1.3 shows histochemical fiber typing in human skeletal muscle demonstrating different myofibrillar ATPase reactions after preincubation at pH 4.6. In this preparation, type I (slow-twitch) fibers stain dark, type IIa fibers remain unstained, and type IIb fibers moderately stained (see Fig. 1.3).

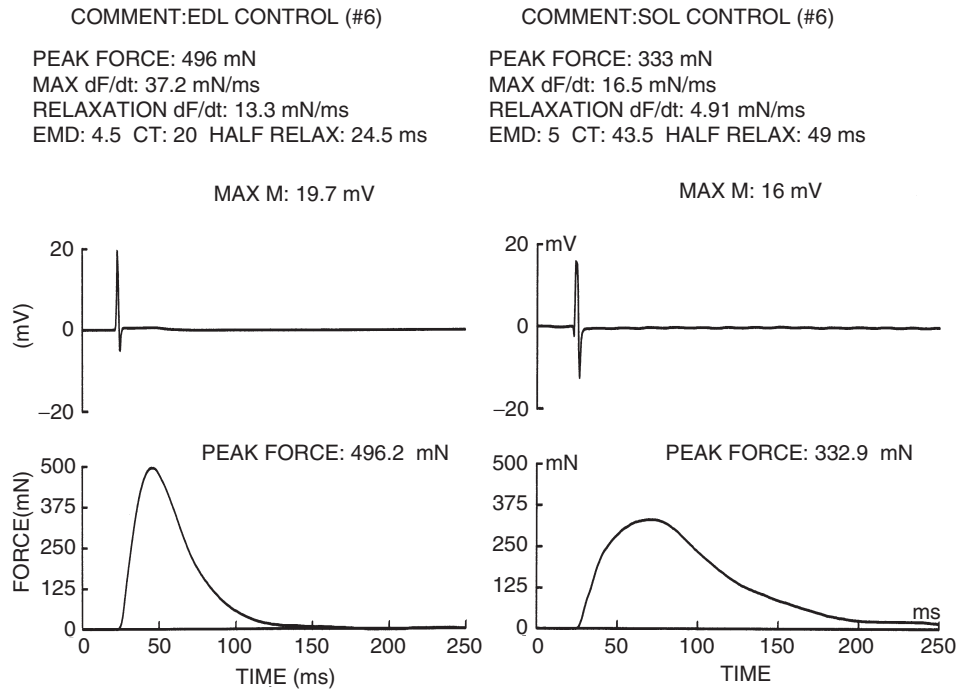

Figure 1.2. Contractile characteristics of typical fast-twitch (*left*: rat EDL) and slow-twitch (*right*: soleus) muscle fibers. EMD: Electromechanical delay (time delay between the onset of EMG and the onset of force). CT: Contraction time (time from onset to peak of force).

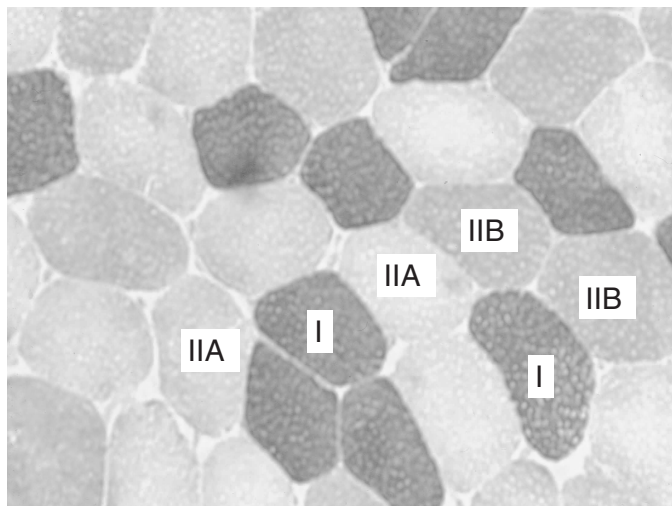

Figure 1.3. Histochemical determination of human muscle fiber types.

During aerobic work glycolytic energy metabolism furnishes pyruvate, which is then transferred to the mitochondria where its carbon skeleton is entirely degraded to CO_2 through oxidative phosphorylation. This process of full oxidation of glucose in mitochondria yields 36 ATP molecules for each glucose molecule degraded. Note that anaerobic glycolysis of glucose to pyruvate only yields 2 ATP with a subsequent formation of lactic acid, which may affect muscle contractile activity. Thus the net ATP production differs by a factor 18 between aerobic and anaerobic energy metabolism. Consequently type I fibers are fatigue resistant due to their high oxidative metabolism and their higher energy efficiency.

Type II (fast-twitch) fibers stain weaker for succinic dehydrogenase than type I fibers, but stain stronger for the enzymes necessary for anaerobic metabolism. Type II fibers therefore generate the ATP for muscular contraction mainly through anaerobic glycolysis, which results in the production of lactic acids and other metabolic by-products. They possess small amounts of mitochondria, and their power output during repetitive activation cannot be achieved through ATP production by oxidative process in their mitochondria. Thus type II fibers are prone to fatigue quickly because they accumulate lactic acids (up to 30-fold the concentration in resting muscle). The low pH associated with this lactate accumulation, as well as the corresponding increases in free phosphate and other metabolic by-products, inhibits the chemical reactions including the myosin ATPase, slowing contraction speed or stopping active contraction entirely (see Fig 1.4). The different metabolic pathways are activated depending on the speed, the intensity, and the duration of muscular contraction.

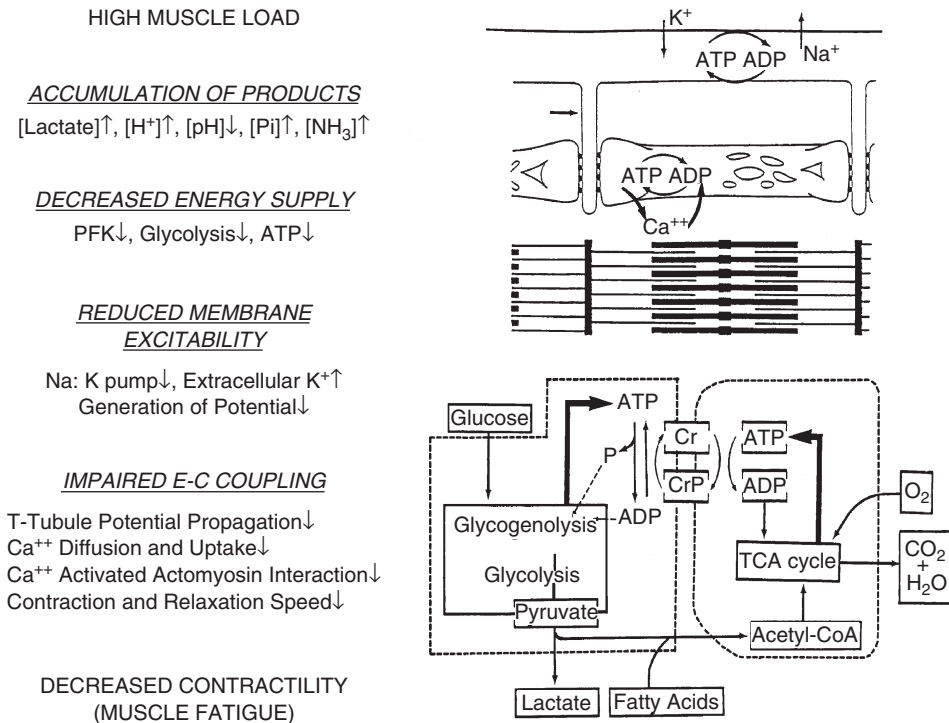

Figure 1.4. Possible metabolic and electrophysiologic consequences of muscular activity that lead to fatigue.

TABLE 1.1. Summary of Different Motor Units and Their Physiological Properties

Motor Unit Type	Histochemical and Metabolic Properties	Mechanical Properties	Electrical Properties	Others
S or SO or type I	Oxidative, do not work well in ischemic or low oxygen conditions	Slow twitch, small forces, fatigue resistant, smaller fiber diameter and MU size	Lower nerve conduction velocity	Small axons recruited at low force levels
FR or FOG or type IIa	Oxidative glycolytic	Fast twitch, fatigue resistant	Intermediate nerve conduction velocity	Intermediate axons recruited at moderate force levels
FF or FG or type IIb	Glycolytic, work well in ischemic or low oxygen conditions	Fast twitch, large forces, fatigable, larger fiber diameter and MU size	High nerve conduction velocity	Large axons recruited at high force levels

In addition the MU type is not only reflected in mechanical and histological differences but also in the single-fiber action potential and in the MU action potential features. Wallinga et al. [102] investigated the action potential of individual muscle fibers of the rat soleus (type I) and the extensor digitorum longus (EDL, predominantly type II). They found that in comparison to type I fibers, type II fibers have more negative resting potential, larger peak excursion, faster rate of depolarization and repolarization and shorter action potential duration. Furthermore type I and types IIa and IIb muscle fibers appear to be randomly distributed across the muscle cross section. Depending on the muscle function, the percentage of the two fiber types may be different. Antigravity muscles (e.g., soleus) tend to be predominantly type I, while muscles suitable for rapid movements have similar proportions of the two fiber types. Table 1.1 summarizes different MU properties.

1.2.2 Motor Unit Recruitment and Firing Frequency (Rate Coding)

In voluntary contractions, force is modulated by a combination of MU recruitment and changes in MU activation frequency (rate coding) [54,69,72]. The greater the number of MUs recruited and their discharge frequency, the greater the force will be. During full MU recruitment the muscle force, when activated at any constant discharge frequency, is approximately 2 to 5 kg/cm², and in general, this is relatively independent of species, gender, age, and training status [1,41].

Our current understanding of motor unit recruitment is based on the pioneer work of Henneman and colleagues in the 1960s, who proposed that motor units are always recruited in order of increasing size of the α -motoneuron. This “size principle” of Henneman et al. [34] was based on results from cat motoneurons and is supported by strong evidence that in muscle contraction there is a specific sequence of recruitment in order of increasing motoneuron and motor unit (MU) size [18,24,54,69]. Goldberg and Derfler [28] later showed positive correlations among recruitment order, spike amplitude, and twitch tension of single MUs in human masseter muscle. Because of the great wealth

of data supporting this size-based recruitment order in a variety of experimental conditions, it is often referred to as the “normal sequence of recruitment” or “orderly recruitment” [32]. Recent data further confirm the presence of this “size principle,” and that transcortical stimulation generates normal orderly recruitment [3].

It is well documented that motor unit recruitment and firing frequency (rate coding) depend primarily on the level of force and the speed of contraction. When low-threshold MUs are recruited, this results in a muscular contraction characterized by low force-generating capabilities and high fatigue resistance. With requirements for greater force and/or faster contraction, high-threshold fatigable MUs are recruited [24,33]. The technical difficulties associated with single motor unit recordings at high forces in humans and the difficulty in generating controlled forces in animal preparations limit the accuracy with which the precise motor unit recruitment and rate coding can be established. However, Kukulka and Clamann [54] and Moritani et al. [74] demonstrated in human adductor pollicis that for a muscle group with mainly type I fibers, rate coding plays a prominent role in force modulation. For a muscle group composed of both types I and II fibers, MU recruitment seems to be the major mechanism for generating extra force above 40% to 50% of maximal voluntary contraction (MVC). Thus, in the intrinsic muscles of human hands, motor unit recruitment appears to be essentially complete at about 50% of maximal force, but recruitment in the biceps, brachialis, and deltoid muscles may continue until more than 80% of maximal force is attained [18,54,72,81].

The number of MUs recruited and their mean discharge frequency of excitation determine the electrical activity in a muscle, that is, there are the same factors that determine muscle force [5,72]. Thus a direct relationship between the electromyogram (EMG) and exerted force might be expected. Under certain experimental conditions this relationship can be demonstrated by recording the smoothed rectified or integrated EMG (iEMG) [20,68,71,73]. The reproducibility of EMG recordings is remarkably high, as the test–retest correlation ranges from 0.97 to 0.99 [52,71,73].

Figure 1.5 represents a typical set of raw surface EMG recording together with the corresponding force curve during force-varying isometric muscle contraction. Surface EMG frequency power spectral data are also shown. It can be readily seen that EMG activity increases progressively as a function of force generated, suggesting a gradual MU recruitment and MU firing rate modulation taking place in order to match the required force demand. Thus the increase in EMG amplitude might represent MU recruitment and/or MU firing frequency modulation whereas the increase of mean frequency (MPF) of the power spectrum might represent, at least in part, the additional recruitment of superficial high threshold MUs that most likely possess large and sharp spikes affecting high frequency bands of the surface EMG power spectrum [72].

However, the change in the surface EMG should not automatically be attributed to changes in either MU recruitment or MU firing frequencies as the EMG signal amplitude is further influenced by the individual muscle fiber potential, degree of MU discharge synchronization, and fatigue [5,6,7,44,75,82]. A direct single motor unit recording with bipolar wire electrodes is shown for comparison (Fig. 1.6) during the same experimental condition previously described. Note that the isolated MU spikes can be observed. Additional motor units as represented by greater spike amplitudes could be identified even at near 80% of maximal force production.

Several previous studies [69,98] have demonstrated that the firing rates of active motor units increase monotonically with increasing force output. This may imply that increased excitation to the active muscle motoneuron pool increases the firing rates of all the active motor units. In addition to this common increase, common fluctuations of firing rates are

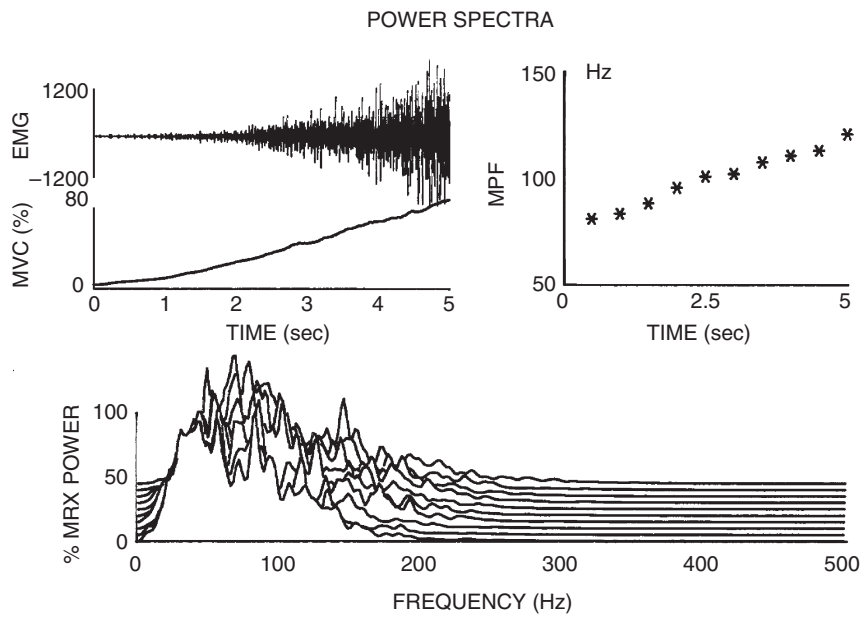

Figure 1.5. Typical set of computer outputs showing the changes in raw EMG signal recorded from the biceps brachii muscle and the corresponding frequency power spectra during linearly force-varying isometric muscle action.

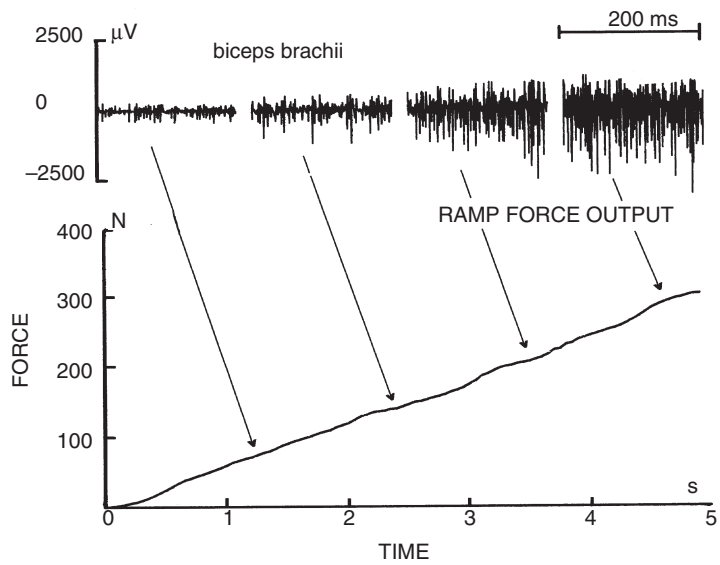

Figure 1.6. Intramuscular spike recordings obtained from the biceps brachii muscle during linearly force-varying isometric muscle contraction.

often present. De Luca et al. [18] investigated this commonality in the fluctuations of the firing rates of up to eight concurrently active motor units during various types of isometric muscle action: attempted constant force, ramp force increase, and force reversals. Their results strongly indicated that there was a unison behavior of the firing rates of motor units, both as a function of time and force. This property has been termed the “common drive.” The existence of this common drive implies that the nervous system does not control the firing rates of motor units individually. Instead, it modulates the pool of motoneurons in a uniform fashion; a demand for force modulation can be achieved by modulation of the excitation and/or inhibition on the motoneuron pool as a whole.

1.2.3 Factors Affecting Motor Unit Recruitment and Firing Frequency

Muscle Action. It is well established that eccentric (lengthening) contraction requires less oxygen and lower amount of ATP than concentric contraction [15,42]. Both surface [53] and intramuscular EMG studies [76] have demonstrated that MU recruitment patterns are qualitatively similar in both types of contractions, but for a given MU, the force at which MU recruitment occurs is greater in eccentric contractions than in either isometric or concentric (shortening) contractions.

On the other hand, selective recruitment of type FF motor units has been most clearly demonstrated by comparing different types of muscle actions of the human gastrocnemius and soleus muscles [86,87]. Motor units with low recruitment thresholds observed during concentric (shortening) muscle action were apparently suppressed during eccentric (lengthening) muscle action. Interestingly muscle soreness that has a delayed onset is a common feature among both athletes and untrained individuals. A number of investigators have demonstrated that the eccentric component of dynamic work plays a critical role in determining the occurrence and severity of exercise-induced muscle soreness [25,66,91]. It has been also demonstrated that type II fibers are predominantly affected by this type of muscular contraction [25]. Based on these findings and the results of EMG studies cited earlier, it is most likely that muscle soreness associated with eccentric component of dynamic exercise might be in part due to high mechanical forces produced by relatively few active MUs, which may in turn result in some degree of disturbance in structural proteins in muscle fibers, particularly those of high recruitment threshold MUs.

As movement speed increases, the force supplied by type S motor units decreases much more rapidly than that supplied by type FF units because of differences in their force-velocity relations. As a consequence it has been proposed that rapid movements may be accomplished by selective recruitment of type FF motor units. This selective recruitment of either slow or fast ankle extensor muscles has been documented during a variety of locomotor tasks in cats [37,95]. For example, Smith et al. [95] demonstrated selective recruitment of the fast LG muscle during rapid paw shaking without concomitant recruitment of the slow SOL muscle, possibly due to the time constraints imposed by the rapid movements during which the recruitment of slow muscle would be incompatible with the demands of the movement. Studies in humans have generally not supported this idea. Moritani et al. [78,79], however, reported some evidence of phase-dependent and preferential activation of the relatively “fast” gastrocnemius muscle (as compared to “slow” soleus) with increasing demands of force and speed during different types of hopping in man. In the arm muscles the order of recruitment appears dependent on the specific task requirements, especially movement speed and direction [99]. DeLuca and Erim [17] have recently proposed a model of common drive of motor units that provides a possible scheme

for the control of MUs, unifying various seemingly different or isolated past research findings. According to this model the pool of MUs that makes up a muscle is controlled not individually but collectively during a contraction. The unique firing patterns of individual MUs are affected not by separate command signals sent to these units but by one common motor drive to which MUs respond differently. Considering the simplicity of this “common drive” and the previously described size principle, the control of the MUs within a muscle represents a functional elegance that relates the specifics of the hierarchical grading to the local size-related excitation of the MUs. This would obviously free the central nervous system to provide a global input to the motoneuron pool corresponding to the intended output of the muscle (see [17] for more details). A proposal for the special behavior of the motoneuron action potential as a dominant stage in this process was recently made by Kleine et al. [50] on the basis of experimental work of Matthews [65].

Muscle Fatigue. Earlier electromyographic studies [5,75,82] indicated that the amplitude of EMG signals increases progressively as a function of time during sustained fatiguing submaximal contractions. In the wide range of submaximal contractions not all of the available motor units of the pool are recruited. Simultaneous recordings of single motor unit spikes and surface EMG analysis demonstrated that there was a progressive decrease in mean power frequency (MPF) of the surface EMG signal during sustained contractions at 50% of MVC, but this decline was accompanied by a significant increase in the root mean square value of the EMG amplitude and a progressive MU recruitment as evidenced by an increased number of MUs with relatively large intramuscular spike amplitude [75]. It was generally assumed that additional MUs were progressively recruited to compensate for the loss of contractility due to some degree of impairment of fatigued MUs. However, this increased amplitude of the surface EMG could not be demonstrated during sustained maximal voluntary contractions (MVC) [7,8,82]. There was some evidence that a progressive reduction occurs in MU firing rates during sustained MVC in the absence of any measurable neuromuscular transmission failure [9,75]. This finding suggests the existence of different MU recruitment and rate-coding mechanisms during sustained maximal and submaximal voluntary contractions.

On the other hand, an important feature of the neuromuscular system is its plasticity and capability to evolve, adapt, and repair itself. This feature makes it possible to compensate for age-related deterioration, to benefit from training in sport, to adapt to a particular job or physical activity, and so on [88]. It is known that athletes active in resistance sport (e.g., long-distance runners and swimmers) have a higher percentage of type I fiber cross-sectional area than athletes involved in explosive performances (e.g., sprinters). Interestingly aging skeletal muscles exhibit a progressive decrement in cross section and maximal isometric contraction force. The effects of aging on the characteristics of skeletal muscles are fiber type specific. The decline in fiber number and size is more prominent for type II fibers than for type I [13], leading to the paradox of an aged muscle being more fatigue resistant than a young one.

Energy Metabolism and Oxygen Availability. During cycling exercise an increase in plasma lactate concentration occurs already at 50% to 70% of maximal oxygen uptake (V_{O_2max}) and well before the aerobic capacity is fully utilized [103,104]. However, at the exercise intensity with a considerable amount of lactate production, the actual torque is usually less than 20% of maximal voluntary contraction. Despite these relatively low force output and moderate speed of contractions (60 revolution per minute) during cycling, glycogen content of types IIa and IIb fibers is progressively decreased (first in type IIa

and finally type IIb) [100], suggesting a decrease in the motor unit recruitment threshold force of these fibers during development of fatigue.

Gollnick et al. [30] showed that in isometric muscle actions, slow-twitch fibers are the only ones to be depleted of glycogen at force developments up to 15% to 20% MVC. Above this level, fast-twitch fibers are also depleted of glycogen. This suggests that above 20% MVC, the availability of oxygen and the developed force influences recruitment of fast motor units, since blood flow is usually restricted during sustained contraction about 20% MVC [39]. These available data suggest that not only the force and speed of contraction but also the availability of oxygen and energy substrates affect the recruitment of high threshold motor units. An early recruitment of slow-twitch MU recruitment in 30% MVC fatiguing tibialis anterior muscle exercise was found in an ^{31}P -NMR spectroscopy study by Houtman et al. [38].

To further shed a light on this issue of energy supply and motor unit recruitment and rate coding pattern, Moritani et al. [83] experimentally determined the interrelationships among oxygen supply, motor unit activity, and blood lactate during intermittent isometric contractions of the hand grip muscles. Subjects performed for 2 seconds 20% of MVC followed by 2 seconds of rest repeated for 4 minutes under free circulation and/or arterial occlusion between the first and second minutes. The constancy of both intramuscular motor unit spikes and surface EMG activity during isometric contraction indicated no electrophysiological signs of muscular fatigue with free circulation condition. However, significant changes in the above-mentioned parameters were evident during contractions with arterial occlusion. Since the availability of oxygen and blood-borne substrate, such as glucose and free fatty acids, are severely reduced during occlusion, a progressive recruitment of additional motor units might have taken place so as to compensate for the deficit in force development [6,75]. This may occur if motor units become depleted of glycogen [30,100] or affected by some degree of intramuscular acidification [67,105]. This in turn interferes with the excitation-contraction (E-C) coupling with subsequent decrease in the developed force. Under these physiological conditions, if the force output were to be maintained, a progressive recruitment of additional MUs with possibly more glycolytic (types IIa and IIb) fibers would take place.

These results suggest that not only the force and speed of contraction but also the availability of oxygen and/or energy substrates may affect the recruitment of high threshold motor units. In good agreement with this hypothesis, the ^{31}P NMR experiments [12] demonstrated that the rate of recovery in PCr/inorganic phosphate (Pi) during the contraction was dependent on oxygen delivery. These results and other evidence [48] suggest a causal relationship between oxygen supply and energy state in the contracting as well as recovering skeletal muscles. It is therefore reasonable to believe that oxygen availability may play an important role in regulating MU recruitment and firing frequency as there exists a close link between state of energy supply and types of muscle fibers being recruited [75,80,83].

1.2.4 Peripheral Motor Control System

There are a variety of specialized receptors located in the muscles, tendons, fascia, and skin that provide information to appropriate parts of the central nervous system (CNS) concerning the length and force characteristics of the muscles. The simplest functional element of the motor activity is the so-called stretch reflex. Reflexes are largely automatic, consistent, and predictable reactions to sensory stimuli. A physician taps a patient's

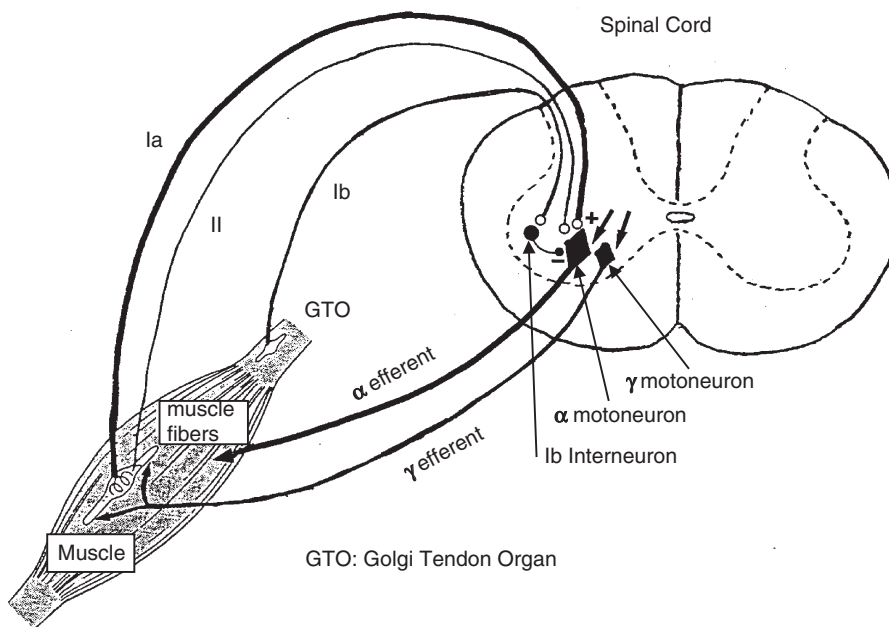

Figure 1.7. Schematic representation of the reflex components.

knee and the leg extends. This is an example of a very simple reflex: the stretch reflex. Figure 1.7 schematically illustrates the basic components involved in this stretch reflex.

Within each muscle are sensory receptors called muscle spindles. Spindles provide information to the nervous system regarding the absolute length of the muscle and the rate of change of the length (velocity) of the muscle. The tap stretches the muscle. This stretch is detected by the muscle spindle and is conveyed directly to a spinal motoneuron via sensory afferent (group Ia afferent). This leads to excitation of motoneuron and efferent impulses that cause contraction of the corresponding muscle. This way the muscle is shortened, the stretching of the muscle spindles is removed and their Ia afferent activity diminishes. In the process only one synapse is involved: a sensory Ia afferent to motoneuron. The term monosynaptic is therefore typically used to describe the stretch reflex. Although the stretch reflex is termed monosynaptic, the sensory afferent from the spindle also contacts interneurons, sensory neurons, and neurons that send ascending projections to higher centers such as thalamus. From there, processed messages return to the motoneurons, closing a longer parallel reflex arc. The stretch reflex therefore also has polysynaptic components (i.e., involving more than one synapse). Note that all reflexes, no matter how simple, can be modified by signals from the brain.

Muscle spindles are composed of intrafusal fibers, sensory endings, and motor axons. Each spindle contains several intrafusal fibers and sensory endings and is innervated by specialized motoneurons (fusimotor neurons or gamma [γ] motoneurons). The neural input to muscle spindles comes from fusimotor neurons located in the spinal cord (see Fig. 1.7). The main function of fusimotor neurons is to control the sensitivity of spindle afferents to dynamic stretches by innervating intrafusal fibers. Some fusimotor neurons (beta [β] motoneurons) innervate both extrafusal (skeletal) and intrafusal (muscle spindle) fibers.

As just described, muscle spindles are only one of many types of receptors that provide information necessary for movement. Control of posture and movement requires

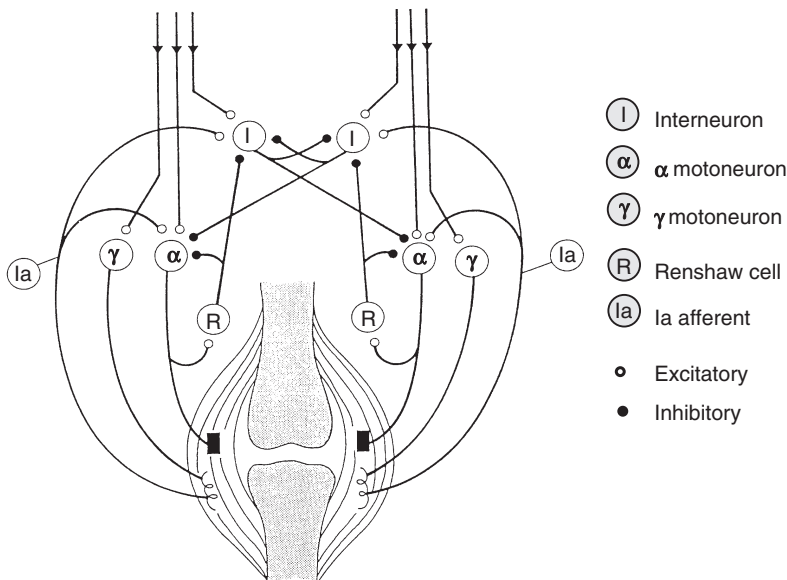

Figure 1.8. Stretch reflex neural circuitry and neural-mechanical coupling between antagonistic pairs of limb muscles. (Modified from [70] with permission)

monitoring not only of muscle length but also of muscle tension. We do possess another specialized receptor called the Golgi tendon organ (GTO). GTOs are specialized sensory receptor organs located primarily in the musculotendinous junction. GTOs provide information regarding the amount of force, or tension, being generated within the muscle. Thus the functioning of these peripheral receptors (muscle spindles and GTOs) is absolutely essential to the control of muscle contraction. GTOs have a low threshold (i.e., they tend to respond to small changes) to contraction-induced changes in muscle tension, and at higher threshold to stretch-induced tension. The sensory information detected by the GTO receptors is conveyed via group Ib sensory afferents (see Fig. 1.7). Group Ib afferents from GTOs mediate nonreciprocal inhibition. Nonreciprocal inhibition, also termed autogenic inhibition, refers to inhibitory input to an agonist (i.e., the prime mover) and its synergists concomitant with an excitatory input to opposing (antagonist) muscles. The inhibition of agonist motoneuron pools and the excitation of antagonist motoneurons are accomplished by Ib interneurons. This type of inhibition assists with the matching of muscle forces to the requirements of a motor task [55]. Ib interneuron can be either facilitatory or inhibitory. GTO activation therefore results in many other responses in addition to nonreciprocal inhibition.

It is now important to realize that smooth coordinated movement relies not only on muscle activation but on muscle deactivation as well. When you are trying to extend the leg, it would be impossible if muscles that opposed that movement were contracting. As previously described, the Ia afferent that convey stretch reflex information branch when they enter the spinal cord (see Fig. 1.8). Some of these branches synapse on interneurons. One type of interneuron that is contacted is the Ia inhibitory interneuron. So when you try to extend the leg, the muscle spindles of the leg extensor will be stimulated and cause stretch reflex together with excitation of this Ia inhibitory interneuron that will have an

inhibitory effect on motoneurons innervating muscles that are antagonists to the stretched muscle, in this case the flexor muscles. This process is referred to as reciprocal inhibition or disynaptic inhibition because two synapses are involved in the inhibitory pathway. The Ia inhibitory interneuron receives rich convergent inputs from many other sources and processes in such a way that the appropriate amount of antagonist muscle inhibition is achieved. Obviously different motor tasks require varying degrees of antagonist muscle inhibition and synergist muscle activation.

Inhibition of antagonists and other muscle groups can also be accomplished by Renshaw cell mediated inhibition, Ib-mediated inhibition (presented earlier in GTO description), and presynaptic inhibitory mechanisms. Renshaw cells are interneurons that directly synapse on alpha motoneurons and Ia inhibitory interneurons (see Fig. 1.8). The Renshaw cell will inhibit the alpha motoneuron of a contracting muscle and its synergists. In addition it will inhibit the antagonist muscle's Ia inhibitory interneuron (disinhibition). This aids in grading muscle contractions and assisting task-appropriate agonist/antagonist cocontraction [55].

During various stages of ontogenetic development, neural projections exist that are not normally present in the adults [56]. These neonatal "exuberant" projections appear to retract or become physiologically latent during development. Neural activity definitely plays a critical role in retraction and segregation within the nervous system. The gradual reduction of exuberant neural projections is related to competition for synaptic sites [29] and early redundancy yields to refinement based on a proper matching of afferents and efferents. Competitive interactions between projections are modulated by neural activity and thus removal of competition may result in an abnormal retention of neonatal neural exuberance.

Damaging the motor cortex of cats during the neonatal stage, for example, results in developmental delays and reflex changes similar to those seen in children with cerebral palsy [56,57]. A series of studies by Leonard [59,60] have investigated the effects of neonatal neuronal exuberance and its retention following damage to the central nervous system (CNS) in humans. Figure 1.9 demonstrates a typical set of results obtained from deep tendon reflex testing and surface EMG recordings obtained from a normal infant and a child with cerebral palsy. In normal infants a single tendon tap to either the patellar or Achilles tendon elicited reflex responses in agonist, antagonist, and other leg muscles (see Fig. 1.9). By 5 years of age this reflex overflow was greatly reduced. Children with cerebral palsy did not have a reduction of reflex overflow. Instead, the infantile pattern of reflex distribution to antagonist and other muscles was maintained. Children with cerebral palsy thus seem to have a delayed or absence of reflex development rather than an aberrant development.

The reflex overflow recorded in normal infants and children with cerebral palsy can best be explained by (1) exuberant Ia projections that extend to motoneurons innervating muscles other than the one being stimulated, (2) exuberant motoneuron projections, and/or (3) a lack of supraspinal input that normally would depress reflex activity. The abolition of reflex overflow in normal children and adults may thus reflect either retraction of exuberant neural projections and/or gating of spinal cord reflexes by maturing supraspinal input [59]. H-reflex studies enabling the quantification of spinal motoneuron pool excitability have also indicated that children with cerebral palsy have impairments in reciprocal inhibition, both before and during voluntary movement [60]. These deficits, which involve damage to supraspinal centers, contribute to their inability to perform smooth, coordinated movements [58].

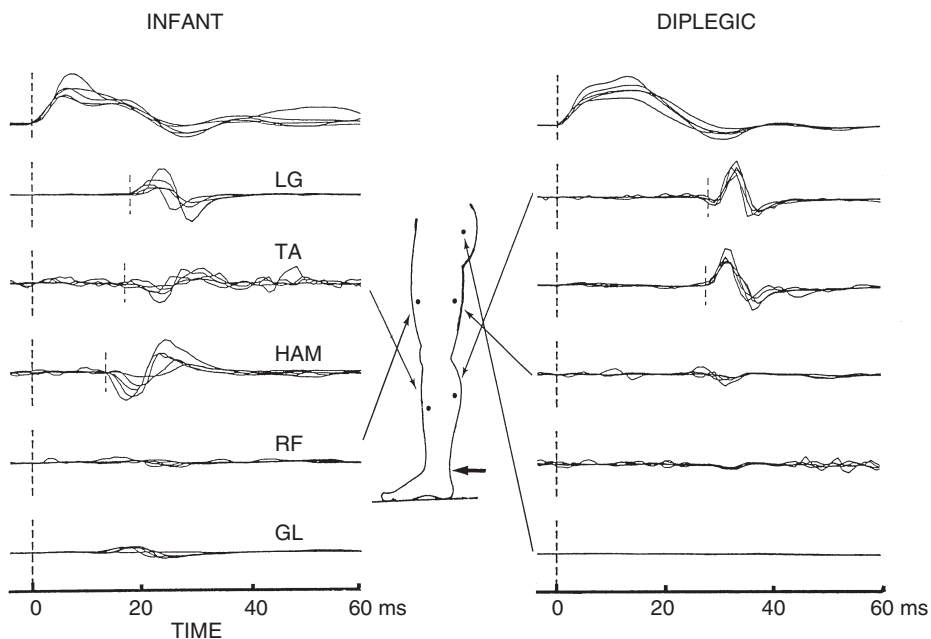

Figure 1.9. Five superimposed reflex responses following an Achilles tendon tap in a normal 8-month-old infant (*left*) and a 13-year-old child with spastic diplegia (*right*). Note that the infant had monosynaptic reflex responses in several muscles following the Achilles tendon tap. The 13-year-old child with diplegia had reflex activation similar to those of the normal infant. *Top plot:* Tendon-tap pressure. LG: Lateral gastrocnemius; TA: Tibialis anterior; HAM: Hamstrings; RF: Rectus femoris; GL: Gluteus maximus. (Modified from [58] with permission)

1.2.5 Muscle Energetics and Neuromuscular Regulation

The transition from aerobic to anaerobic muscle metabolism has been a subject for special focus in human experiments. The level of muscular work just below that at which metabolic acidosis occurs has been called the anaerobic threshold (AT) [103]. The physiological requirements for performing muscular work above AT are considerably more demanding than for lower intensities. Lactic acidosis (anaerobic) threshold occurs at a metabolic rate that is specific to the individual and is usually caused by an inadequate oxygen supply [4,48,104]. Thus the AT can be considered an important assessment of the ability of the cardiovascular system to supply oxygen at a rate adequate to prevent muscle anaerobiosis (lactate acidosis) during muscular work [104].

Earlier EMG and ventilatory studies [11,77] demonstrated a sharp and well-defined rise in the previously stable EMG amplitude and ventilation upon applying an arterial occlusion cuff to the leg while working at a constant level of power output on the bicycle ergometer. Since the EMG activity levels were very constant and showed no electrophysiological sign of fatigue prior to the occlusion, it can be assumed that some shift in the MU recruitment and/or firing frequency takes place due to local muscle hypoxia caused by the occlusion [77,83]. On the other hand, the observed sharp increase in ventilation from its steady state level after the occlusion may be mediated through some neural path-

ways to the respiratory center [19,46], since the abrupt occlusion of the circulation to and from the exercising limb would isolate the respiratory center and the central chemoreceptors from the effects of chemical products of muscle metabolism. If one could assume that the sharp increases in EMG activity during the occlusion represent the summation of a progressively increasing MU recruitment and firing frequency due to the compensation of reduced contractility of some fatigued MUs, a progressive increase in the extracellular K^+ , for example, could be expected as a result of increased MU activities. By this means the ventilatory response could be stimulated via a neural pathway in the absence of circulation. In agreement with these results, Busse et al. [11] showed some evidence that ventilatory and thereby $[H^+]$ regulation can be accounted for by the plasma $[K^+]$ concentration and mechano-physiological properties of the peripheral muscles, respectively.

The above-mentioned discussion clearly suggests that there must be a tight link between muscle energy metabolism and neural excitation processes. Prolongation and reduction in the evoked action potential have been reported during high-frequency nerve stimulation [73,74] or during ischemic contractions [21], indicating a possible dependency on energy supply for muscle membrane function. Furthermore the depletion of extracellular Na^+ has been shown to accelerate the rate of force fatigue in the isolated curarized preparation [45]. This reduction of extracellular $[Na^+]$ or accumulation of K^+ may reduce the muscle membrane excitability sufficiently during high-frequency tetani to account for the excessive loss of force [45,74]. Thus energy metabolism clearly plays an important role in regulating neural excitation and electrolyte balance within the cell.

There has been some evidence that a decrease in intracellular pH can interfere with muscular contractile function. For example, the increase in $[H^+]$ has been shown to interfere with Ca^{++} binding to troponin, suggesting the possible participation of $[H^+]$ in excitation-contraction coupling with subsequent deficit in the developed tension [85]. The findings of Karlsson et al. [47] suggest that at tensions of 30% to 50% MVC, the increase in lactate is responsible for fatigue by direct or indirect changes in pH. However, at higher and lower tensions the possibility that lactate is directly implicated in the development of fatigue is remote, as electrical and metabolic factors can further complicate this phenomenon [7,8,75,82,89].

For example, the results of NMR study [22] demonstrated that PFK-deficient patients who could not produce lactic acid showed virtually no change in pH during muscle fatigue. Hence other possible mechanisms must be considered. Accumulation of inorganic phosphate (Pi) and ammonia (NH_4^+), for example, has also been shown to occur during muscular activity as possible inhibitory metabolites contributing to fatigue [35,84]. It has been suggested that Pi may bind to myosin in such a way so as to increase the forward rate of cross-bridge cycling and thereby to reduce force output [14]. Other evidence of Pi-induced force reduction is that patients with McArdle's disease demonstrated greater fatigability than normal individuals and a concomitantly larger increase in Pi accumulation [61].

At present, the specific messenger to which the motor control system responds with varying patterns of motor unit recruitment and firing frequency has not yet been clearly established. There is some evidence that MU recruitment order might be modified by changes in the proprioceptive afferent activity [31,49]. Other, and possibly more likely, explanations might be that the stretch receptors in muscle spindles and Golgi tendon organs could signal the need for adding more motor units [23,26,40,49,90] as a result of a fall in contractility of some motor units affected by the reduced oxygen supply and/or depletion of intramuscular glycogen store [12,30,100]. Or there may be some influences on the motoneuron pool activity from the sensory afferent nerve fibers originating in the "metaboreceptors" [62,94].

1.3 BASIC ELECTROPHYSIOLOGY OF THE MUSCLE CELL MEMBRANE

1.3.1 The Hodgkin-Huxley Model

The skeletal muscle fiber membrane is the seat of the bioelectric phenomena that result in the EMG signal. Most studies on excitable cell electrophysiology have been focused on nerve cells (in particular on the squid giant axon). The membrane of a muscle cell is more complex than the membrane of a nerve cell, it has layers and invaginations and electrical parameters different from those of a nerve cell. The invaginations are referred to as the tubular system, or T-system, which is a network of branching tubules radially oriented into the fibers. These tubules form a pathway for radial current flows that conduct the action potential from the outer membrane (the sarcolemma) into the sarcoplasmic reticulum and play a role in the excitation contraction coupling. A correct analysis of the electrical properties of the muscle fiber should include the tubular system, which considerably complicates a model of the muscle membrane [64].

For the sake of simplicity, in many studies and in this book, the same model describing nerve cell membrane is used as a first approximation for muscle cell membrane. This model was first proposed in the classical work of Hodgkin and Huxley in 1952 [36] and describes, with an equivalent nonlinear electrical circuit, the behavior of the three main ionic channels, as depicted in Figure 1.10. The key point of the model is the dynamic voltage-dependent behavior of the membrane permeability to the three main ions. The time course of the sodium and potassium conductances is qualitatively depicted in the left portion of Figure 1.10. Because of this voltage dependence and the different dynamic behaviors of the sodium and potassium conductances, a transient membrane voltage phenomenon takes place whenever a membrane voltage threshold value is crossed (see Fig. 1.10). This phenomenon, which can be thought of as the one generated by a “one-shot” electronic circuit, is referred to as the action potential. It can be initiated by a chemically induced change of the sodium conductance (e.g., triggered in the skeletal muscle fiber by the neurotransmitter “acetylcholine”) or by an externally applied electrical current (e.g., in direct muscle electrical stimulation). Its waveform, amplitude, and duration are strictly determined by the behavior of the ionic channels of the sarcolemma, the outer layer of the muscle fiber membrane.

Recently many neurological diseases have been identified, also genetically, that originate in the dysfunction of ion channels (channelopathies), whereby the identification of defects in the muscle fiber membrane play an important role [16]. For the EMG signal, the K^+ , the Na^+ , and the Cl^- channels in the sarcolemma (and in the T-system, as a second approximation) are essential. Force production is dominated by channels through which Ca^{++} ions are released. Electric membrane properties were already studied in detail around the mid-twentieth century with voltage clamp techniques. The understanding of individual membrane ion channels is an important challenge for modern cell biology and electrophysiology [2], for which the so-called patch clamp techniques were a crucial development [96].

Another essential tool for understanding membrane electrophysiology came by way of the development of nonlinear dynamic membrane models, in which the mutual interaction between the different channels are described quantitatively [101]. The classical work of Hodgkin and Huxley (1952 [36]) stood at the basis of these models as well. Their description of the giant axon of the squid gave an amazing replication of real membrane experiments. Later, with modern electrophysiological and histological experiments, it was found that the model dynamics appeared to reflect real life structural elements in the axon's

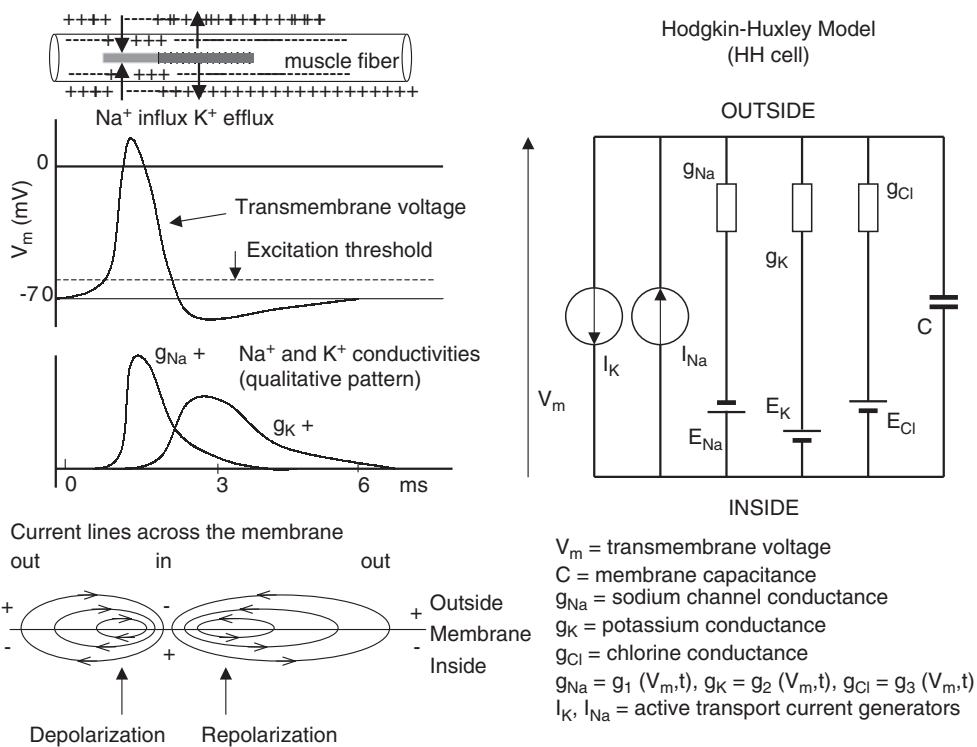

Figure 1.10. Hodgkin-Huxley model (right) and the generation of action potential in an excitable cell (left).

ion channels, one of the main examples of how even relatively abstract models can robustly relate to the structure and function of elements of living tissue. The importance of these achievements for the understanding of EMG may seem not obvious at first sight. Nevertheless, the source of all extracellular bioelectric activity can be found in the ion channel dynamics. This applies to the initiation, the propagation, and extinction of action potentials, the latter being especially important in surface EMG [51]. For practical purposes, knowledge of the waveform in time and space of the intracellular or transmembrane action potential at the sarcolemma suffices for the understanding of surface EMG. The insight attained is by way of the volume conduction mediated potential field set up by the ionic membrane current densities entering and leaving the sarcolemma [101] (Fig. 1.11). Which aspects of an action potential wave shape are essential for a proper description of the extracellular EMG signal can hardly be predicted without the use of a quantitative model of volume conduction (see Chapters 4 and 8).

Figure 1.11 expands these concepts showing a muscle membrane section subdivided in elementary areas, each described with the simplified HH cell model depicted in Figure 1.10. The figure shows the current lines generated by the local depolarization and caused by the events described in Figure 1.10. These currents produce a number of effects: first, by flowing into the nearby membrane areas, ahead of the depolarization front (see Fig. 1.12), they extend and propagate the action potential; second, by flowing into the volume conductor external to the fiber, they generate voltage drops into such volume, including the skin, and generate the extracellular action potential. These voltage drops constitute the single fiber contribution to the EMG signal, which can be detected either with intramus-

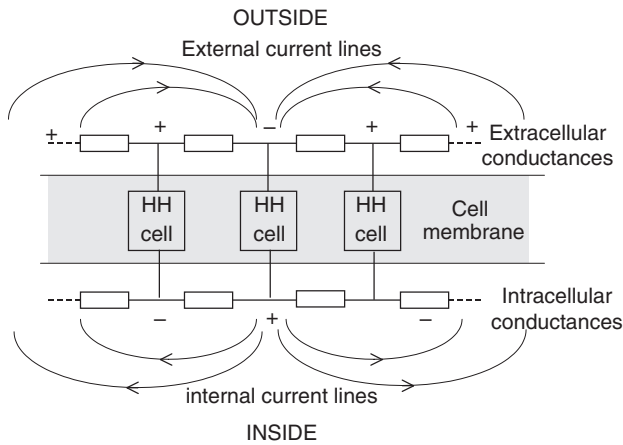

Figure 1.11. Segment of an excitable cell described as a sequence of Hodgkin-Huxley (HH) cells. Current lines resulting from a local depolarization are indicated.

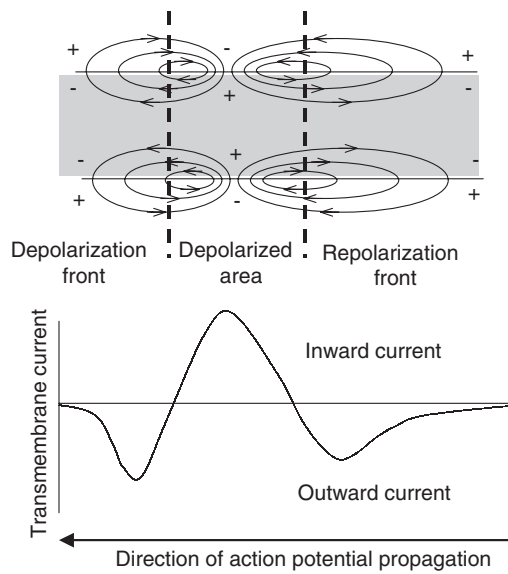

Figure 1.12. Schematic diagram of an action potential propagating along a muscle fiber. The current lines, depicted as ellipses, flow into the volume conductor generating voltages detectable between two electrodes placed into the volume conductor or on the skin. These voltages are contributions of the single fiber to the EMG.

cular needles or thin wires. (Needle and wire detection techniques will be discussed in Chapter 2 while surface detection will be discussed in Chapter 4.)

1.3.2 Propagation of the Action Potential along the Muscle Fiber

As indicated in Figure 1.12, the transmembrane current flow in the depolarization front of the action potential is in the direction that causes the membrane voltage to approach and

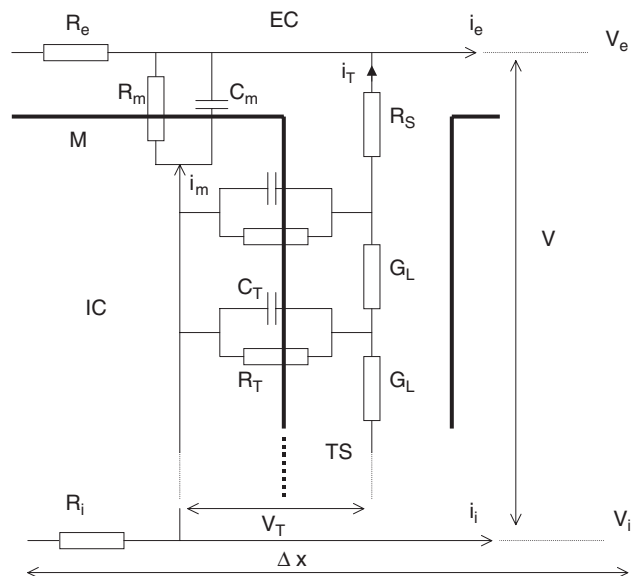

Figure 1.13. Model of a section of length Δx of a muscle fiber, showing the membrane (M), the tubular system (TS), the extracellular space (EC), the intracellular space (IC). The equivalent electrical circuit of a patch of the sarcolemma and T-system is described as a nonlinear resistance and a capacitor. The conductance of a tubule is G_L and i_T is the current flowing in it through the access resistance R_s . The transmembrane voltage V is the difference between the local extracellular and intracellular voltages V_e and V_i while V_T is the tubular potential. R_i and R_e are the intra- and extracellular resistances connecting to the next section. (Redrawn from [92] with permission)

cross the threshold for excitation. As a consequence the action potential moves to the left, with a velocity that depends on the fiber diameter and whose physiological range is between 3 m/s and 5 m/s with an average around 4 m/s. This propagation velocity is referred to as conduction velocity (CV) and is related to membrane properties. Such properties, which are reflected by the muscle fiber action potential, are different in different fiber types. Contradictory findings are reported in the literature [43,63] concerning the effect of fiber diameter (and length) on CV although most reports indicate that larger fibers show higher CV. The role of membrane folds and T-tubule system in determining CV is still unclear.

Figure 1.13 shows a schematic diagram of a T-tubule invagination redrawn from [92]. The role of the T-system is to allow flow of calcium ions into the sarcoplasmic reticulum, a fact leading to cell contraction through a series of biochemical events. The characteristics of this system may affect (and therefore be reflected by) membrane electrical properties and phenomena. The tubular system is an important component, indicating that the classical membrane models developed for the squid axon may not be suitable for an accurate description of muscle-fiber membrane phenomena.

REFERENCES

1. Alway, S. E., J. Stray-Andersen, W. J. Grumbt, and W. J. Gonyea, "Muscle cross sectional area and torque in resistance-trained subjects," *Eur J Appl Physiol* **60**, 86–90 (1990).

REFERENCES

2. Ashcroft, F. M., *Ion channels and disease*, Academic Press, San Diego, 2000.
3. Bawa, P., and R. N. Lemon, "Recruitment of motor units in response to transcranial magnetic stimulation in man," *J Physiol (Lond)* **471**, 445–464 (1993).
4. Beaver, W. L., K. Wasserman, and B. J. Whipp, "Bicarbonate buffering of lactic acid generated during exercise," *J Appl Physiol* **60**, 472–478 (1986).
5. Bigland-Ritchie, B., "EMG/force relations and fatigue of human voluntary contractions," *Exer Sports Sci Rev* **9**, 75–117 (1981).
6. Bigland-Ritchie, B., E. Cafarelli, and N. K. Vollestad, "Fatigue of submaximal static contractions," *Acta Physiol Scand* **28** (suppl), 137–148 (1986).
7. Bigland-Ritchie, B., D. A. Jones, and J. J. Woods, "Excitation frequency and muscle fatigue: electrical responses during human voluntary and stimulated contractions," *Exp Neurol* **64**, 414–427 (1979).
8. Bigland-Ritchie, B., R. Johansson, O. J. C. Lippold, and J. J. Woods, "Contractile speed and EMG changes during fatigue of sustained maximal voluntary contraction," *J Neurophysiol* **50**, 313–324 (1983).
9. Bigland-Ritchie, B., R. Johansson, O. J. C. Lippold, S. Smith, and J. J. Woods, "Changes in motoneuron firing rates during sustained maximal voluntary contractions," *J Physiol* **340**, 335–346 (1983).
10. Burke, R. E., "Motor units: Anatomy, physiology and Functional organization," in V. B. Brooks, ed., *Handbook of physiology: The nervous system*, American Physiological Society, Bethesda, 1981, pp. 345–422.
11. Busse, M. W., N. Maassen, and H. Konrad, "D. Boning, "Interrelationship between pH, plasma potassium concentration and ventilation during intense continuous exercise in man," *Eur J Appl Physiol* **59**, 256–261 (1989).
12. Bylund-Fellenius, A. C., P. M. Walker, A. Elander, J. Holm, and T. Schersten, "Energy metabolism in relation to oxygen partial pressure in human skeletal muscle during exercise," *Biochem J* **200**, 247–255 (1981).
13. Capodaglio, P., and M. V. Narici, "The aging nervous system and its adaptation to training," *Advances in Rehabilitation*, Maugeri Foundation Books, Pavia, Italy (2000).
14. Cooke, R., and E. Pate, "Inhibition of muscle contraction by the products of ATP hydrolysis: ADP and phosphate," *Biophys J* **47**, 25 (1985).
15. Davies, C. T. M., and C. Barnes, "Negative (Eccentric) work. II. Physiological responses to walking uphill and downhill on a motor-driven treadmill," *Ergonomics* **15**, 121–131 (1972).
16. Davies, N. P., and M. G. Hanna, "Neurological channelopathies: diagnosis and therapy in the new millennium," *An Med* **31**, 406–420 (1999).
17. DeLuca, C. J., and Z. Erim, "Common drive of motor units in regulation of muscle force," *Trend Neurol Sci* **17**, 299–305 (1994).
18. DeLuca, C. J., R. S. LeFever, M. P. McCue, and A. P. Xenakis, "Behavior of human motor units in different muscles during linearly varying contractions," *J Physiol (Lond)* **329**, 113–128 (1982).
19. Dempsey, J. A., H. V. Forster, N. Dledhill, and G. A. dePico, "Effects of moderate hypoxemia and hypocapnia on CSF [H⁺] and ventilation in man," *J Appl Physiol* **38**, 665–674 (1975).
20. deVries, H. A., "Efficiency of electrical activity as a measure of the functional state of muscle tissue," *Am J Phys Med* **47**, 10–22 (1968).
21. Duchateau, J., and K. Hainault, "Electrical and mechanical failures during sustained and intermittent contractions," *J Appl Physiol* **58**, 942–947 (1985).
22. Edwards, R. H. T., M. J. Dawson, D. R. Wilkie, R. E. Gordon, and D. Shaw, "Clinical use of nuclear magnetic resonance in the investigation of myopathy," *Lancet* **1**, 725–731 (1982).

23. Enoka, R. G., and D. G. Stuart, "The contribution of neuroscience to exercise studies," *Federation Proc* **44**, 2279–2285 (1985).
24. Freund, H. J., H. J. Budingen, and V. Dietz, "Activity of single motor units from human forearm muscles during voluntary isometric contractions," *J Neurophysiol* **38**, 993–946 (1975).
25. Friden, J., M. Sjoström, and B. Ekblom, "Myofibrillar damage following intense eccentric exercise in man," *Int J Sports Med* **4**, 170–176 (1983).
26. Garnett, R., and J. A. Stephens, "Changes in the recruitment threshold of motor units produced by cutaneous stimulation in man," *J Physiol (Lond)* **311**, 463–473 (1981).
27. Garnett, R. A. F., M. J. O'Donovan, J. A. Stephens, and A. Taylor, "Motor unit organization of human medial gastrocnemius," *J Physiol (Lond)* **287**, 33–43 (1979).
28. Goldberg, L. J., and B. Derfler, "Relationship among recruitment order, spike amplitude, and twitch tension of single motor units in human masseter muscle," *J Neurophysiol* **40**, 879–890 (1977).
29. Goldberger, M. E., "Spared-root deafferentation of a cat's hindlimb: hierarchical regulation of pathways mediating recovery of motor behavior," *Exp Brain Res* **73**, 329–342 (1988).
30. Gollnick, P. D., J. Karlsson, K. Piehl, and B. Saltin, "Selective glycogen depletion in skeletal muscle fibers of man following sustained contractions," *J Physiol (Lond)* **241**, 59–66 (1974).
31. Grimby, L., and J. Hannerz, "Disturbances in voluntary recruitment order of low and high frequency motor units on blockades of proprioceptive afferent activity," *Acta Physiol Scand* **96**, 207–216 (1976).
32. Heckman, C. J., and M. D. Binder, "Computer simulation of the effects of different synaptic input system on motor unit recruitment," *J Neurophysiol* **70**, 1827–1840 (1993).
33. Henneman, E., and L. M. Mendell, "Functional organization of the motoneuron pool and its inputs," in V. B. Brooks, ed., *Handbook of physiology: The nervous system*, American Physiological Society, Bethesda, 1981, pp. 423–507.
34. Henneman, E., G. Somjen, and D. O. Carpenter, "Functional significance of cell size in spinal motoneurons," *J Neurophysiol* **28**, 560–580 (1965).
35. Hibberd, M. G., J. A. Dantzing, D. R. Trentham, and Y. E. Goldman, "Phosphate release and force generation in skeletal muscle fibers," *Science* **228**, 1317–1319 (1985).
36. Hodgkin A. L., and A. F. Huxley, "A quantitative description of membrane current and its application to conduction and excitation in nerve," *J Physiol* **117**, 500–544 (1952).
37. Hodgson, J. A., "The relationship between soleus and gastrocnemius muscle activity in conscious cats—A model for motor unit recruitment?" *J Physiol* **337**, 553–562 (1983).
38. Houtman, C. J., A. Heerschap, M. J. Zwarts, and D. F. Stegeman, "pH heterogeneity in tibial anterior muscle during isometric activity studied by ³¹P-NMR spectroscopy," *J Appl Physiol* **91** 191–200 (2001).
39. Humphreys, P. W., and R. A. Lind, "The blood flow through active and inactive muscles of the forearm during sustained hand-grip contractions," *J Physiol (Lond)* **166**, 120–135 (1963).
40. Hutton, R. S., and D. L. Nelson, "Stretch sensitivity of Golgi tendon organs in fatigued gastrocnemius muscle," *Med Sci Sports Exer* **18**, 69–74 (1986).
41. Ikai, M., and T. Fukunaga, "A study on training effect on strength per unit cross-sectional area of muscle by means of ultrasonic measurements," *Int Angew Physiol Arbeitsphysiol* **28**, 173–180 (1970).
42. Infante, A. A., D. Klaupiks, and R. E. Davies, "Adenosine triphosphate changes in muscle doing negative work," *Science* **62**, 595–604 (1964).
43. Jack, J., D. Noble, and R. Tsien, *Electrical current flow in excitable cells*, Clarendon Press, Oxford, 1985.
44. Jessop, J., and O. C. J. Lippold, "Altered synchronization of motor unit firing as a mechanism for long-lasting increases in the tremor of human hand muscles following brief, strong effort," *J Physiol (Lond)* **269**, 29P–30P (1977).

REFERENCES

45. Jones, D. A., B. Bigland-Ritchie, and R. H. T. Edwards, "Excitation frequency and muscle fatigue: mechanical responses during voluntary and stimulated contractions," *Exp Neurol* **64**, 401–413 (1979).
46. Kao, F. F., "Experimental study of the pathways involved in exercise hyperpnea employing cross-circulation techniques," in D. J. C. Conningham, and B. B. Lloyd, eds., *Regulation of Human Respiration*, Blackwell Scientific, Oxford, 1963.
47. Karlsson, J., C. F. Funderburk, B. Essen, and A. R. Lind, "Constituents of human muscle in isometric fatigue," *J Appl Physiol* **38**, 208–211 (1975).
48. Katz, A., and K. Sahlin, "Regulation of lactic acid production during exercise," *J Appl Physiol* **65**, 509–518 (1988).
49. Kirsch, R. F., and W. Z. Rymer, "Neural compensation for muscular fatigue: Evidence for significant force regulation in man," *J Neurophysiol* **57**, 1893–1910 (1987).
50. Kleine, B. U., D. F. Stegeman, D. Mund, and C. Anders, "The influence of motoneuron firing synchronization on surface EMG characteristics in dependence of electrode position," *J Appl Physiol* **91**(4), 1588–1599 (2001).
51. Kleinpenning, P. H., T. H. Gootzen, A. Van Oosterom, and D. F. Stegeman, "The equivalent source description representing the extinction of an action potential at a muscle fiber ending," *Math Biosci* **101**, 41–61 (1990).
52. Komi, P. V., and E. R. Buskirk, "Reproducibility of electromyographic measurements with inserted wire electrodes and surface electrodes," *Electromyogr* **4**, 357–367 (1970).
53. Komi, P. V., and J. T. Viitasalo, "Changes in motor unit activity and metabolism in human skeletal muscle during and after repeated eccentric and concentric contractions," *Acta Physiol Scand* **100**, 246–256 (1977).
54. Kukulka, C. G., and H. P. Clamann, "Comparison of the recruitment and discharge properties of motor units in human brachial biceps and adductor pollicis during isometric contractions," *Brain Res* **219**, 45–55 (1981).
55. Leonard, C. T., *The neuroscience of human movement*, Mosby, St. Louis, 1998.
56. Leonard, C. T., and M. E. Goldberger, "Consequences of damage to the sensorimotor cortex in neonatal and adult cats. I. Sparing and recovery of function," *Dev Brain Res* **32**, 1–14 (1987).
57. Leonard, C. T., and M. E. Goldberger, "Consequences of damage to the sensory motor cortex in neonatal and adult cats. II. Maintenance of exuberant projections," *Dev Brain Res* **32**, 15–30 (1987).
58. Leonard, C. T., H. Hirschfeld, and H. Forssberg, "The development of independent walking in children with cerebral palsy," *Dev Med Child Neurol* **33**, 567–577 (1991).
59. Leonard, C. T., H. Hirschfeld, T. Moritani, and H. Forssberg, "Myotatic reflex development in normal children and children with cerebral palsy," *Exp Neurol* **111**, 379–382 (1991).
60. Leonard, C. T., T. Moritani, H. Hirschfeld, and H. Forssberg, "Deficits in reciprocal inhibition of children with cerebral palsy as revealed by H reflex testing," *Dev Med Child Neurol* **32**, 974–984 (1990).
61. Lewis, S. F., R. G. Haller, J. D. Cook, and R. L. Nunnally, "Muscle fatigue in McArdle's disease studied by ³¹P-NMR: effect of glucose infusion," *J Appl Physiol* **59**, 1991–1994 (1985).
62. Mahler, M., "Neural and humoral signals for pulmonary ventilation arising in exercising muscle," *Med Sci Sports Exer* **11**, 191–197 (1979).
63. Martin, A., "The effect of change in length on conduction velocity in muscle," *J Physiol* **125**, 215–220 (1954).
64. Mathias, R., R. Eisenberg, and R. Valdiosera, "Electrical properties of frog skeletal muscle fibers interpreted with a mesh model of the tubular system," *Biophysical J* **17**, 57–93 (1977).
65. Matthews, P. B., "Relationship of firing intervals of human motor units to the trajectory of post-spike after-hyperpolarization and synaptic noise," *J Physiol* **492**, 597–628 (1996).

66. McCully, K. K., and A. Faulkner, "Characteristics of lengthening contractions associated with injury to skeletal muscle fibers," *J Appl Physiol* **61**, 293–299 (1986).
67. Metzger, J. M., and R. L. Moss "Greater hydrogen ion-induced depression of tension and velocity in skinned single fibers of rat fast than slow muscles," *J Physiol (Lond)* **393**, 724–742 (1987).
68. Milner-Brown, H. S., and R. B. Stein, "The relation between the surface electromyogram and muscular force," *J Physiol (Lond)* **246**, 549–569 (1975).
69. Milner-Brown, H. S., R. B. Stein, and R. Yemm, "Changes in firing rate of human motor units during linearly changing voluntary contractions," *J Physiol (Lond)* **230**, 371–390 (1973).
70. Moore, M. A., and R. S. Hutton, "Electromyographic investigation of muscle stretching technique," *Med Sci Sports Exer* **12**, 322–329 (1980).
71. Moritani, T., and H. A. deVries, "Neural factors versus hypertrophy in the time course of muscle strength gain," *Am J Phys Med* **58**, 115–130 (1979).
72. Moritani, T., and M. Muro, "Motor unit activity and surface electromyogram power spectrum during increasing force of contraction," *Eur J Appl Physiol* **56**, 260–265 (1987).
73. Moritani, T., and H. A. deVries, "Reexamination of the relationship between the surface integrated electromyogram (IEMG) and force of isometric contraction," *Am J Phys Med* **57**, 263–277 (1978).
74. Moritani, T., M. Muro, and A. Kijima, "Electromechanical changes during electrically induced and maximal voluntary contractions: Electrophysiologic responses of different muscle fiber types during stimulated contractions," *Exp Neurol* **88**, 471–483 (1985).
75. Moritani, T., M. Muro, and A. Nagata, "Intramuscular and surface electromyogram changes during muscle fatigue," *J Appl Physiol* **60**, 1179–1185 (1986).
76. Moritani, T., S. Muramatsu, and M. Muro "Activity of motor units during concentric and eccentric contractions," *Am J Phys Med* **66**, 338–350 (1988).
77. Moritani, T., A. Nagata, and M. Muro, "Electromyographic manifestations of neuromuscular fatigue of different muscle groups during exercise and arterial occlusion," *J Phys Fitness Jpn* **30**, 183–192 (1981).
78. Moritani, T., L. Oddsson, and A. Thorstensson, "Activation patterns of the soleus and gastrocnemius muscles during different motor tasks," *J Electromyogr Kinesiol* **1**, 81–88 (1991).
79. Moritani, T., L. Oddsson, and A. Thorstensson, "Phase dependent preferential activation of the soleus and gastrocnemius muscles during hopping in humans," *J Electromyogr Kinesiol* **1**, 34–40 (1991).
80. Moritani, T., T. Takaishi, and T. Matsumoto, "Determination of maximal power output at neuromuscular fatigue threshold," *J Appl Physiol* **74**, 1729–1734 (1993).
81. Moritani, T., M. Muro, A. Kijima, and M. J. Berry, "Intramuscular spike analysis during ramp force output and muscle fatigue," *Electromyogr Clin Neurophysiol* **26**, 147–160 (1986).
82. Moritani, T., M. Muro, A. Kijima, F. A. Gaffney, and A. Persons, "Electromechanical changes during electrically induced and maximal voluntary contractions: Surface and intramuscular EMG responses during sustained maximal voluntary contraction," *Exp Neurol* **88**, 484–499 (1985).
83. Moritani, T., W. M. Sherman, M. Shibata, T. Matsumoto, and M. Shinohara, "Oxygen availability and motor unit activity in humans," *Eur J Appl Physiol* **64**, 552–556 (1992).
84. Mutch, B. J. C., and E. W. Banister, "Ammonia metabolism in exercise and fatigue: A review," *Med Sci Sport Exer* **15**, 41–50 (1983).
85. Nakamaru, Y., and A. Schwartz, "The influence of hydrogen ion concentration on calcium binding and release by skeletal muscle sarcoplasmic reticulum," *J Gen Physiol* **59**, 22–32 (1972).
86. Nardone, A., and M. Schieppati, "Shift of activity from slow to fast muscle during voluntary lengthening contractions of the triceps surae muscles in humans," *J Physiol* **395**, 363–381 (1988).

REFERENCES

87. Nardone, A., C. Romano, and M. Schieppati, "Selective recruitment of high-threshold human motor units during voluntary isotonic lengthening of active muscles," *J Physiol* **409**, 451–471 (1989).
88. Narici, M. V., G. S. Roi, L. Landoni, A. E. Minetti, and P. Cerretelli, "Changes in force, cross-sectional area and neural activation during strength training and detraining of the human quadriceps," *Eur J Appl Physiol* **59**, 310–319 (1989).
89. Nassar-Gentina, V., J. V. Passonneau, J. L. Vergara, and S. I. Rapaport, "Metabolic correlates of fatigue and recovery from fatigue in single frog muscle fibers," *J Gen Physiol* **72**, 593–606 (1978).
90. Nelson, D. L., and R. S. Hutton, "Dynamic and static stretch responses in muscle spindle receptors in fatigued muscle," *Med Sci Sports Exer* **17**, 445–450 (1985).
91. Newham, D. J., K. R. Mills, B. M. Quigley, and R. H. T. Edwards, "Pain and fatigue after concentric and eccentric muscle contractions," *Clin Sci* **64**, 55–62 (1983).
92. Reichel, M., W. Mayr, and F. Rattay, "Computer simulation of field skeletal muscle fiber interpreted with a mesh model of tubular system," *Biophysical J* **17**, 57–93 (1977).
93. Sale, D. G., "Neural adaptation to strength training," in P. V. Komi, ed., *Strength and power in sport*, Blackwell Publishing, Oxford, 1991.
94. Sjøgaard, G., "Exercise-induced muscle fatigue: The significance of potassium," *Acta Physiol Scand* **140** (Suppl), 1–63 (1990).
95. Smith, J. L., B. Betts, V. R. Edgerton, and R. F. Zernicke, "Rapid ankle extension during paw shakes: Selective recruitment of fast ankle extensors," *J Neurophysiol* **43**, 612–620 (1980).
96. Sperelakis, N., "Patch clamp and single-cell voltage clamp techniques and selected data. Mol Cell" *Biochem* **80**, 3–7 (1998).
97. Stephens, J. A., and T. P. Usherwood, "The mechanical properties of human motor units with special reference to their fatigability and recruitment threshold," *Brain Res* **125**, 91–97 (1977).
98. Tanji, J., and M. Kato, "Firing rate of individual motor units in voluntary contraction of abductor digiti minimi in man," *Exp Neurol* **40**, 771–783 (1973).
99. Van Bolhuis, B. M., W. P. Medendorp, and C. C. A. M. Gielen, "Motor-unit firing behaviour in human arm flexor muscles during sinusoidal isometric contractions and movements," *Brain Res* **117**, 120–130 (1997).
100. Vollestad, N. K., O. Vaage, and L. Hermansen, "Muscle glycogen depletion patterns in type I and subgroups of type II fibers during prolonged severe exercise in man," *Acta Physiol Scand* **122**, 433–441 (1984).
101. Wallinga, W., S. L. Meijer, M. J. Alberink, M. Vlieg, E. D. Wienk, and D. L. Ypey, "Modeling action potentials and membrane currents of mammalian skeletal muscle fibres in coherence with potassium concentration changes in the T-tubular system," *Eur Biophys J* **28**, 317–329 (1999).
102. Wallinga-De Jonge, W., F. F. Gielen, P. Wirtz, P. De Jong, and J. Broenink, "The different intracellular action potentials of fast and slow muscle fibers," *Electroenc Clin Neurophysiol* **60**, 539–547 (1985).
103. Wasserman, K., B. J. Whipp, S. N. Koyal, and W. L. Beaver, "Anaerobic threshold and respiratory gas exchange during exercise," *J Appl Physiol* **35**, 236–243 (1973).
104. Wasserman, K., W. L. Beaver, and B. J. Whipp, "Gas exchange theory and the lactic acidosis (anaerobic threshold)," *Circulation* **81** (Suppl), II14–II30 (1990).
105. Wilkie, D. R., "Muscular fatigue: effects of hydrogen ions and inorganic phosphate," *Fed Proc* **45**, 2921–2923 (1986).

