

## Chapter 1

# Introducing the World of Illustrator

### *In This Chapter*

- ▶ Getting a look at how graphic artists use Illustrator
- ▶ Becoming familiar with the Illustrator interface
- ▶ Noting some Mac and Windows differences
- ▶ Creating new documents
- ▶ Saving your artwork
- ▶ Printing Illustrator documents
- ▶ Bailing out of a document (and Illustrator itself)

**T**he first time you run Illustrator, you'll probably think that Adobe *Intimidator* would be a more appropriate name for Adobe Illustrator. The program's dozens of tools, hundreds of commands, and more than 30 palettes can transform confident, secure individuals into drooling, confused, and frustrated drones.

The situation doesn't have to be that way, of course. Sure, all that stuff is scary. Even more frightening to some is the prospect of facing the giant white nothingness of the Document window — the endless possibilities, the confusion over where to start. This chapter helps you get past that initial stage and move forward into the mystical state of *eagerly awaiting* (instead of fearing) each new feature and function.

## *From Humble Origins to Master of the Graphics Universe*

As its box proudly proclaims, Adobe Illustrator is the “Industry Standard Graphics Software.” But the software didn't always enjoy that standing. Illustrator evolved from a geeky math experiment into the graphics powerhouse it is today.

## 12 Part I: Driving People Crazy — Illustrator's Bum Rap

### *A brief history of Illustrator*

Until the mid-1980s, computer art was limited to blocky-looking video games, spheroid reflections, and the movie *Tron*. Then something happened to change all that (in addition to Jeff Bridges' refusal to make a sequel) — PostScript, a computer language created especially for printers. Adobe created PostScript specifically to help printers produce millions of teeny-tiny dots on the page, without running out of memory. (Graphics files were notoriously huge relative to the teeny tiny computers of the day.)

In 1987, Adobe released Illustrator 1.1, which was designed primarily to be a *front end* for PostScript — a way to make its capabilities actually usable. At that time, the concept of artwork that is scalable to any size *without loss of quality* (one world-beating advantage of creating art within Illustrator) was brand new. Illustrator gave companies the opportunity to have electronic versions of their logos that could be printed at *any* size.

In the ten-plus years since Version 1.1, Adobe Illustrator has become the Web-ready, giant application that it is today. Millions of people around the world use Illustrator, and its *thousands* of features, big and small, meet a wide variety of graphics needs. Oddly enough, the one aspect of Illustrator that *hasn't* changed is the perceived intimidation factor. Version 1.1 had several tools, many menu items, a neurosis-inducing Pen tool, Bézier curves, and that way-scary blank page when you started it up. Version CS still has nearly every feature that 1.1 did and adds a staggering array of new features including 3D, new type enhancements and Scribble, but it still has that way-scary blank page. Illustrator 1.1 was a playful little kitten compared with the beast that is Illustrator CS!

### *Illustrator's place in the cosmos*

Professional graphic artists have a toolbox of programs that they use to create the books, magazines, newspapers, packaging, advertisements, and Web sites that you see every day. Any professional will tell you that you need the right tool for the job to do the job well. The right tools (in this case) are software products — drawing programs, paint programs, and products for page layout and Web-authoring. *Drawing programs*, such as Adobe Illustrator, are the best tools for creating crisp, professional-looking graphics (such as logos), working with creative type effects, and re-creating photographs from line drawings. *Painting programs* (often called *image editing programs*), such as Adobe Photoshop, provide tools to color-correct, retouch, and edit digital photographs and re-create “natural media” effects, such as hand-painting. Page layout programs, such as Adobe InDesign or QuarkXPress, enable you to combine graphics that you create in drawing and paint programs with text for print publishing. You can use Web-authoring tools (such as Macromedia Dreamweaver or Adobe GoLive) to combine graphics, text, sound, animation, and interactivity for presentation on the World Wide Web.

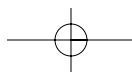

Although each tool performs a fairly specific (if wide-ranging) task, there is some crossover between applications. For example, Illustrator has some limited image editing capabilities, but very few people ever use them. Because you can edit images with complete control and freedom in Photoshop, why use the wrong tool for the job? QuarkXPress enables you to run type along a curve, but Illustrator has so many tools for creative type effects that you'd be silly to do them anywhere else.

By using Illustrator on its own, you can create an astonishing variety of graphics and type effects. When you combine it with paint, page layout, and Web-authoring programs, you have the tools you need to create print and Web publications that match the quality of anything you see in the stands or on-screen today.

In the field of professional graphics and publishing, each software program has to perform only a few basic functions: graphics creation, image editing, page layout (for print), or Web layout.

Illustrator is the *de facto* standard in graphics creation. While there are two competing programs out there (Macromedia FreeHand and CorelDRAW), Illustrator is used three times as much as the other two products combined. This is mainly because it's the best in several ways, from feature breadth and depth to tight integration with other standard applications and formats, including Photoshop and PDF.

Adobe has products in the other categories (two in the page layout category). One benefit of using Illustrator is that it works very well (as you may expect) with the other Adobe products, most of which have a similar interface and way of working. If you know one Adobe product well, chances are you'll have an easy time of figuring out other Adobe products.

Illustrator excels at creating and editing artwork of all types. In fact, you can use Illustrator to create and edit nearly anything that didn't start out as a photograph. (For more about the differences between photographs and artwork created with Illustrator, see Chapter 2.)

## *Starting Up Illustrator and Revving It a Little*

To get Illustrator running, choose Illustrator from the Start menu (Windows) or double-click the application's icon (Mac). (The latter method also works in Windows, if you're a Mac user who happens to be using Windows. Don't worry; I won't tell a soul. Honest.)

## 14 Part I: Driving People Crazy — Illustrator's Bum Rap

The Illustrator startup process displays the *splash screen* — an image to look at while the program is cranking up.

As Illustrator continues the startup process, the flower image disappears and is replaced with something entirely new for Version CS: The Welcome to Adobe Illustrator dialog box, shown in Figure 1-1. The Welcome to Adobe Illustrator dialog box gives the following options to start using Illustrator:

- ✓ **What's New in Illustrator:** This option displays all the new features in the most recent version, with handy tips on how to get the most out of each new feature.
- ✓ **Tutorials:** A video runs, showing both new features as well as basic concepts.
- ✓ **Cool Extras:** This option takes you to special features in the product you may not find otherwise.
- ✓ **New Document:** Click this icon to display the New Document dialog box (as shown in Figure 1-2).
- ✓ **New from Template:** Illustrator ships with an amazing array of professional templates to get you started creating all sorts of snazzy documents, from logos to brochures to DVD box artwork.
- ✓ **Open Document:** This option takes you straight to the Open dialog box, so you can open existing artwork in Illustrator.

Before you start a new document, you have to answer a few questions in the New Document dialog box about the name, page size, units of measurement, orientation, and color mode that you plan to use.

### *What's in a Name (field)?*

You can give your new document a name in the Name field. If you don't, Illustrator names it Untitled-1, and every new document you create is titled sequentially — Untitled-2, Untitled-3, and so on, until you quit the program. When you relaunch, you'll be right back at Untitled-1. If you don't give a name to the new document, you get another chance when you save it. The advantage to naming your document is that if you accumulate a whole bunch of unsaved files (*not recommended!*), you can't tell them apart. Besides, you see the name of the document at the top of the document in the Title bar, so you don't forget what you're doing.

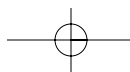

**Figure 1-1:**  
The  
Welcome  
to Adobe  
Illustrator  
dialog box.

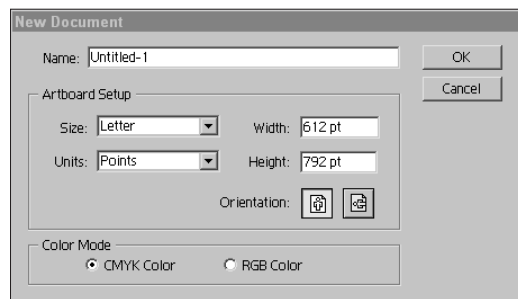

**Figure 1-2:**  
The New  
Document  
dialog box.

## *Page size, units, and orientation*

You set your page size by choosing a predefined size from the Size drop-down menu or by typing values into the Height and Width fields. Your page size truly matters only when you're printing your document directly out of Illustrator. Otherwise, it just exists as a point of reference — a guide to show you how far things are apart from each other. One great thing about Illustrator: For the most part, size doesn't matter (no, really). When you create graphics for the Web, you can determine the size of the graphic when you save it. When you're creating graphics for print, most of the time you'll be creating graphics to be imported into page layout applications, such as QuarkXPress, PageMaker, or

## 16 Part I: Driving People Crazy — Illustrator's Bum Rap

InDesign. In the latter case, although it's always best to size your image in Illustrator, you can scale the graphic to the size you need it in your page layout. In either case, the Web browser or page layout application recognizes your Illustrator drawing, ignoring the page size.

Page size is good for two things: proofing and conceptualization. Often you'll want to print your artwork on paper directly from Illustrator to get an idea of what it looks like. In this case, set the Size to the size paper you've loaded in your printer. While creating graphics, keep in mind the size of the page or browser window that you're creating for — in this case, set the Height and Width to whatever the target output is. For example, if you're creating for the Web, you may want to set the size to 640 pixels x 480 pixels, which is a fairly standard size for computer screens, to help you visualize the final artwork. Actually, you can change the size of the artwork to be anything you want, at any time, and that's one of the great things about creating in Illustrator.



By default, Illustrator measures image size in *points* (1 point =  $\frac{1}{72}$  inch). If that unit of measurement is unfamiliar to you, be sure to select a different unit from the Units drop-down menu. Your ruler also changes (when you choose View → Show Rulers) units to the type you selected. And although it won't change the ruler units, you can also type the unit of measurement along with the number when you specify values for page size in the Height and Width fields. When you open a new document, it comes up showing a width in points — say, for instance, 612 pt. If you want to specify a width of 10 inches or 30 centimeters, just type (respectively) **10 in** or **30 cm** in the Width field. If you don't know the standard abbreviation for a unit of measurement, you can type the whole word out (for example, **10 inches** or **30 centimeters**). Illustrator understands what you mean and does the conversion for you. And it will do so wherever you enter a unit of measurement, not only in the New Document dialog box. Smart, very smart!

### *CMYK or RGB?*

CMYK or RGB? In Illustrator, this question is a bit more significant than the ubiquitous question, "Paper or plastic?" To understand why you have to answer Illustrator's question, you need a little more history and some technobabble. (Sorry, I'll try to keep this brief.)

Illustrator has been around for a long time, back when putting color images on the Web was impossible and interactive multimedia was little more than a buzzword. In those days, the main reason for creating documents in color on the computer was so you could print them out in color. Color printing almost always uses a *CMYK* process — for Cyan, Magenta, Yellow, and black inks (the

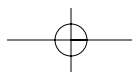

*K* stands for black because RGB has dibs on *B*, which stands for *blue*). These four colors, blended in different amounts, produce the full range of colors you see in printed material. So back then, Illustrator used only CMYK colors because nobody needed to do anything in color besides print.

Then along came interactive multimedia — in effect, the “lights, camera, sound, and action” for computer users. Shortly after that came the Web. Because images used for multimedia and the Web appear only on the computer screen, a need emerged for RGB images. *So what’s RGB, already?* Okay, I’m getting to that: Computer screens create the colors you see by using electrons to make a coating of phosphors glow *Red*, *Green*, or *Blue* (hence RGB) in different intensities. If you’re creating content for multimedia applications or for the Web, you need RGB images that look good on-screen. You probably don’t give two hoots about CMYK. So Illustrator, trying to please everyone, added the capability to create colors in RGB.

Unfortunately, this new feature didn’t quite please *everyone*. In fact, it upset some people quite a lot. And left a wake of money wasted, deadlines blown, marriages ruined, lives lost and empires crushed. (Well, okay, that’s a little exaggeration, but *only* a little.) CMYK and RGB just didn’t get along.

Printing in color meant using the standard four-color printing process: Every image had its own percentage of cyan, magenta, yellow, and black, so four sets of films were made (one for each of those colors); the final printed image combined the colors. Each set consisted of only four single-color plates (C, M, Y, and K) — and that’s all you’d expect to print out. But if your Illustrator file contained any RGB elements (even a few pixels’ worth), you had big trouble: Three additional films would print out — frequently at a cost of \$100 or more per film — for *every* page that contained *any* RGB colors. If you weren’t paying attention, one mistake like that could cost thousands of dollars. And a lot of people weren’t paying attention because they’d never had to worry about RGB colors in an Illustrator file before. (You can bet they did after that!) To prevent this sort of uproar from happening again, Adobe wisely removed the capability to combine CMYK and RGB colors in the same document. That’s why you have to specify CMYK *or* RGB before you start a new document. Sure, it’s a hassle, but you’re *so much* better off having this hassle now, rather than spending money for it later!

So which do you choose, CMYK or RGB? You may think it safe to assume that RGB is for multimedia or the Web and CMYK is for print. Okay, that’s a *safe* assumption, but not necessarily the *best* assumption. If you aren’t sure where you’re going to output, pick RGB. You can always change to CMYK later if you’re required to, and you’ll be able to print directly to color printers just fine that way.

# 18 Part I: Driving People Crazy — Illustrator's Bum Rap

For the sake of your creativity, choose RGB when

- ✔ **You're creating for the Web or for multimedia:** In this situation, you're always creating work that's going to be viewed in RGB and you've no practical reason whatever to use CMYK.
- ✔ **You're creating for print BUT do not need precise CMYK colors:** If you don't have to specify exact CMYK values while you work, choose RGB. (You can convert to CMYK by using File⇨Document Color Mode *before you print* — just don't forget to, okay?) I know that approach sounds like asking for trouble, but I can give you three good reasons for using RGB this way:
  - Some of Illustrator's coolest features (including many Photoshop filter effects) only work with RGB color.
  - When you work in RGB, you can use the full range of colors — *millions* of them — that are possible on the computer. (CMYK only supports mere *thousands* of colors.) If you're creating content for both print and the Web, creating the image in RGB gives you the maximum color range possible in both CMYK *and* RGB.
  - Some desktop inkjet color printers print well in RGB. For example, Epson six color printers print a wider range (gamut) of colors in RGB than in CMYK.

For the sake of accuracy, choose CMYK when

- ✔ **You need precise CMYK colors:** Some artists who create for print use a swatch book of printed CMYK colors. They use only the specific CMYK colors they see in the book because they feel (and rightly so) that this is the only way to get a good idea of what that color will look like when it finally prints. If your designs have to meet such specific requirements, you should always work in CMYK. Some companies specify the exact CMYK colors they want in their publications. If you're working on a project for one of those companies, use CMYK.
- ✔ **You're creating for grayscale or black and white print:** In RGB, shades of gray exist by default as blends of red, green, and blue. If you're printing with black ink, this blending is a hassle because you always have to work with three colors instead of one. In CMYK, however, you can create shades of gray as percentages of black ink, ignoring all other colors (which you may as well do if they won't be visible anyway).

After you answer the three magic New Document questions (name, page specs, and color choice), click OK and behold: A blank page opens, inviting you to realize your creative potential. You're ready to start illustrating. If blank-page syndrome doesn't faze you and you want to dig into the good stuff right away, thumb over to Chapter 2.

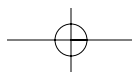

## Exploring the Illustrator Workspace

Between figuring out what the 250+ menu items actually do and rearranging palettes (until you have a tiny little area on your document in which you can actually work), you may find the Illustrator environment a bit daunting. (If you do, you're far from alone.) The next sections are an overview of all the stuff that's preventing you from getting any work done. (That stuff is what the geeks call the *UI* — pronounced *you eye* — for *user interface*.)

### A graphic handyman's Toolbox

The Illustrator Toolbox (that alien artifact in Figure 1-3) is the place that most people start when they use Illustrator. After showing you 24 tools, 6 odd-looking buttons, and a gang of giant square things, the Toolbox pretends that's all there is to it. Actually, the Toolbox has over 50 hidden tools. Call up most tools in Illustrator by clicking (once) the tool you want in the Toolbox. The cursor then changes to either something that looks like the tool, or in the case of special tools (Rectangle, Ellipse, and others) a cross-hair cursor.

The tools live in *toolslots*, which are subdivisions within the Toolbox. Many toolslots contain more than one tool, as indicated by a small black arrow in the bottom-right corner of the toolslot. To access a hidden tool, click and hold the mouse pointer on a tool in its toolslot. You then see a bunch of other (usually related) tools materialize by the toolslot that you clicked (as shown with the Pen tool in Figure 1-3). Use those other tools by dragging to the tool you want to use and releasing the mouse button.



Drag over to the little bar to the right of the hidden tools in the toolslot and let go of the mouse button when the little bar becomes highlighted (refer to Figure 1-3). A separate little window appears containing all the tools from the toolslot. You can place this window anywhere on the screen. This procedure can save your sanity if you're constantly switching between two tools that share a toolslot. To get rid of this toolslot window, click the X (Windows) or the tiny white Close box (Mac) in its upper-left corner.



When you pause the mouse pointer over any tool, the name of the tool appears, followed by a letter. Well, no, the letters aren't grades given to the tools for their usefulness; the letters let you know which keys to press if you want quick access to the tools. (For instance, press the P key on your keyboard to get the Pen tool or R to get the Rotate tool.)

## 20 Part I: Driving People Crazy — Illustrator's Bum Rap

As you gaze at the Toolbox, notice that it doesn't have a Close or Expand box along its top. One possible explanation for this is that you go to the Toolbox for just about everything you do in Illustrator, and it's almost impossible to work without it. If you really want to, though, you can hide the Toolbox by selecting Hide Tools from the Window menu at the top of the screen. To bring back the Toolbox, go to the Window menu again and select Show Tools.



You can hide the Toolbox temporarily — along with your palettes — by pressing the Tab key. Although this feature can be unsettling if you don't know about it (if you hit the Tab key by accident, everything disappears except your graphics and the menu bar!), it's still mighty useful — especially if you're working on a small computer screen. You can work with everything hidden, hit the Tab key when you need to, select the tool or palette item you need, and get back to work unfettered by the things you aren't using. This approach is a lot faster than selecting Show or Hide from the Window menu whenever you want to do something different.

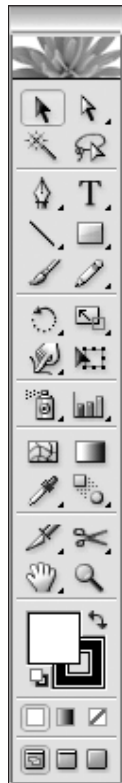

**Figure 1-3:**  
The  
Illustrator  
Toolbox;  
click and  
hold the  
pointer on  
a toolslot  
to display  
all the tools.

## Palettes to suit any artist

Illustrator has a ton of palettes. You may think of a palette as something more closely associated with a painter than an illustrator, but nonetheless, Illustrator has about 30 of them. As with a painter's palette that holds the paints she uses most, an Illustrator palette provides quick access to the most frequently used commands and features. The contents of palettes are organized according to what they do. The Character palette contains commands to format individual pieces or big chunks of text, and the Color palette lets you create and change colors. Although Illustrator has dozens of palettes, you rarely need to have them all open at once. When entering text, for example, you want the Character palette open, but you probably don't need the Gradient palette open because the Gradient palette controls only gradients.

You open a palette by choosing it as a menu item. These all live in the Window menu (such as Window→Colors). To close a palette, click the X (Windows) or the tiny white box (Mac) in its upper-left corner.



Fortunately, Illustrator can both tab and dock palettes to keep them more organized, giving you a wee bit of space in which you can actually draw and edit your artwork. *Tabbing* lets you stack palettes in one area so they overlap like index cards. *Docking* connects the top of one palette to the bottom of another so that both palettes are visible but take up as little space as possible.

By default, Illustrator displays the palettes shown in Figure 1-4. Notice that some of the palettes are grouped into sets and offer you several tabs. (For instance, the Styles, Swatches, Brushes, and Symbols palettes are tabbed together in one set.) Initially, you see only the Styles palette; the Swatches, Brushes, and Symbols palettes are hidden behind the Styles palette. To see either of those palettes, click the tab for the one you want to view.

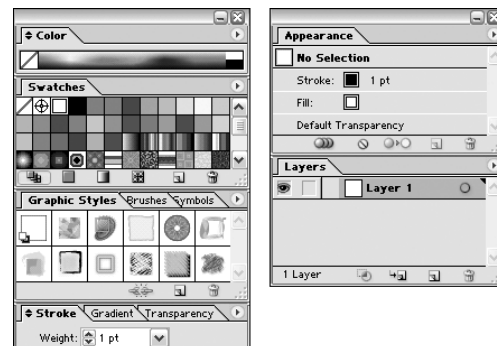

**Figure 1-4:**  
Palettes  
are tabbed  
together  
in a set.

## 22 Part I: Driving People Crazy — Illustrator's Bum Rap

You can combine palettes by any method that you feel works for you. To move a palette from one set to another, click and drag that palette's tab from one set into another — or out by itself (which creates a new set). Illustrator doesn't limit you; you can combine any palette with any set. You can even put all of Illustrator's palettes into one set if you really want to — but I don't advise doing so; the tabs would all overlap so you couldn't tell what's what.

Another way to combine palettes is by docking them together, as shown in Figure 1-5. Unlike tabbed palettes, docked palettes are all out there in plain sight; you can see more than one palette in a set at the same time. To dock one palette to another, drag the tab of the first palette to the bottom of the other palette. A dark line appears on the bottom of the second palette when it's in docking position. When you release the mouse button, the first palette docks with the second one.

Many Illustrator palettes have their own menus, which pop up when you click the triangle in the upper-right corner of the palette, as shown in Figure 1-6.

**Figure 1-5:**  
The Layers palette docked to the Styles palette.



**Figure 1-6:**  
Palettes also have their own menus.

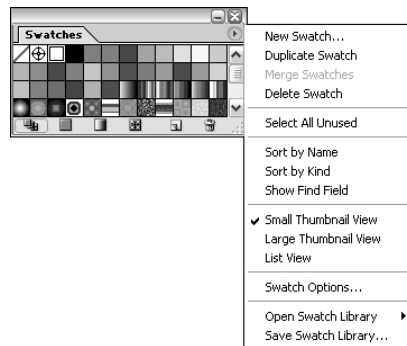

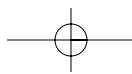

Items in the palettes' pop-up menus relate specifically to each palette. This makes them easy to ignore and easy to figure out — after you master the individual palette.

## *Menus with the finest cuisine*

Illustrator menus are organized fairly well. Some menus are immediately obvious. You find commands having to do with type under the Type menu and commands for viewing your document under the View menu. Other menus are a little less intuitive and make sense only after you start using them. For instance, after you realize that *any one on-screen “thing” in Illustrator is an object*, you discover that items in the Object menu relate to objects. Other menus take a little more work and experimentation to understand. For instance, the Filter menu and the Effects menu have many items that appear identical, yet do very different things. Believe it or not, all these menus are arranged to make figuring out and using Illustrator as easy as possible.

To use an item in a menu, drag down to that item and release. Something should happen when you do that (no explosions or tsunamis — as far as I know), depending on which menu item you select. Even the way a menu item appears on a menu can be a handy tip — for example, consider the following characteristics:

- ✓ **Submenus:** Many of Illustrator's menus have several submenus in them, indicated by a little triangle to the right of the menu item. To access a menu item in a submenu, drag down to the title of the submenu and then over to the item you want to use. (See Figure 1-7.)
- ✓ **Keyboard commands:** Most menu items in Illustrator have keyboard shortcuts (key combinations listed at the right) that can activate them.
- ✓ **More info needed:** An ellipsis (. . .) indicates that when you click the item, a dialog box appears, requesting additional input from you.
- ✓ **Unavailable commands:** A grayed-out menu item means Illustrator won't let you do anything with that item just now.

## *Mac and Windows issues spring eternal*

Okay, I know some loyalties in this area are fierce — can't we all just get along for a while? Regardless of which system you use or like, you work in Illustrator

## 24 Part I: Driving People Crazy — Illustrator's Bum Rap

pretty much the same way. A few little differences are important enough to mention, however, especially if you jump between the two systems:



- ✓ **The .ai extension:** Windows users often need filename extensions after their filenames or the system refuses to look at the files. The Illustrator file extension is `.ai`. That's right, as in *aieee!* but without the *eee!*. Most file types (on Windows systems) have three-letter extensions; Illustrator uses two. Windows folks should save Illustrator documents with the `.ai` extension for maximum compatibility with all flavors of Windows. Having the wrong extension on the file can cause problems. If you were to put `.aif` on there, for example, Windows would try to open the file as a sound file, fail, and give you an error message!

Windows users are accustomed to using two- and three-letter filename extensions. Mac users don't have to, but they really should get in the habit of doing so. For starters, that keeps the peace when you send files and lets you instantly identify what the file is. Illustrator lets you save files in an alphabet soup of file formats, such as PDF (`.pdf`), TIFF (`.tif`), EPS (`.eps`), or JPEG (`.jpg`). Each of these formats has its own unique properties and purposes. When you see `.eps` on a file, chances are good that it's a graphic created for use in a page layout program. When you see `.gif`, you know it's a graphic created for display on the Web. File extensions can tell you a lot about your files even before you open them.

- ✓ **Right-click versus Ctrl+click:** While in Illustrator, Windows users can right-click most places in Illustrator to display a contextual menu (see Figure 1-8). Mac users, who don't have a right mouse button, press the Ctrl key while clicking the mouse button. Contextual menus (clever creatures!) are context-sensitive: They recognize what the mouse is near when you click and give you options you can apply . . . the following, for example:

- Right-click (or Ctrl+click) the Ruler, and a context menu shows up, offering to help you change the Ruler's unit of measurement.
- Right-click (or Ctrl+click) text, and you can change the font, size, and a slew of other options.
- Click a path, and up come the options related to paths, and so on.



All the items found in contextual menus appear in the regular menus, too, so you never really *have* to use contextual menus. They're among those little luxuries (like a steering-wheel-warmer on a cold day) that make Illustrator so nice to use.

- ✓ **Performance:** As of 2003, Windows systems have taken a decisive lead over Macs when it comes to performance. The difference is most apparent with graphics applications such as Photoshop and Illustrator, but you'll

notice it with other applications as well. If you're thinking of purchasing a new system, and speed and responsiveness is important (or at least more important than the feel of the OS), I suggest getting a zippy PC over a (comparably) sluggish Mac.

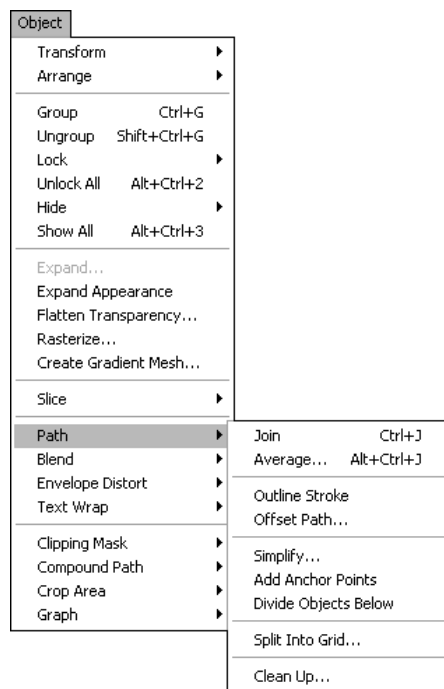

**Figure 1-7:**  
The Path submenu in the Object menu.

**Figure 1-8:**  
A contextual menu appears when you Ctrl+click (Mac) or right-click (Windows).

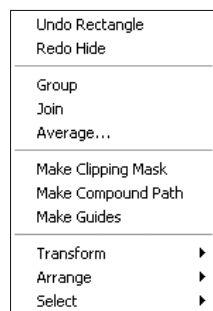

## 26 Part I: Driving People Crazy — Illustrator's Bum Rap

### *Defining the Document Area*

Illustrator uses a traditional art board as a metaphor; it's what you see when you create a new file (shown in Figure 1-9). You have the page you're working on (the Artboard), and the table the page sits on (called the Scratch area, but traditional artists will recognize it as a Pasteboard). When you create a new document, the Artboard appears as a rectangle in the middle of a white expanse. (The actual size and shape of the Artboard depends on what you enter for height and width when you create a new document.)

The Artboard serves as a guide to show how large your artwork is (relative to the page size you chose when you created the document). Many people find it easier to create with a specific page size in mind. If you come from a traditional graphic arts background, you may find the idea of an Artboard and Pasteboard (or Scratch area) reassuring. You can create elements and leave them in the Scratch area, ready for you to grab and add to the artwork you're creating on the Artboard. As to how the Artboard affects your art — well, it doesn't. It's only a guide to help you get your bearings. Elements in the Scratch area still print if you print to large enough paper. If you save your Illustrator artwork as an EPS (Encapsulated PostScript) to bring it into a page layout program (or as a GIF to use on the Web), anything in the Scratch area is saved with it.



If you don't find the Artboard useful as a guide, you can hide it altogether by choosing View⇨Hide Artboard.

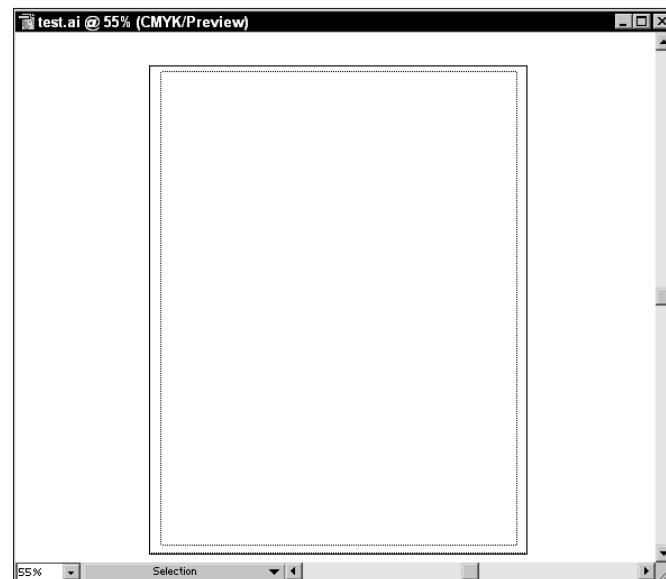

**Figure 1-9:**  
The Artboard and the Scratch area — the first two wiseguys you meet when you create a new Illustrator file.

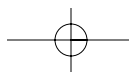

For printing a document, you may find the Page Tiling feature a little more significant than the Artboard. Illustrator smartly recognizes the printer that your document is currently selected to print to and creates a Page Tile (a rectangle), which is the size and shape of the largest area that the selected printer can print. You can recognize the Page Tiling feature by a thin, dotted line that appears just inside the Artboard if you set page size to the size of your printer paper.

Most printers show a printable area slightly smaller than the page size. Anything outside these guides doesn't print. Even so, remember that this guide is based on *your* printer; what's inside someone else's printable area may not be the same.

## Opening Existing Documents

To open any existing Illustrator document, choose File⇨Open and then select the document you want (using the Open dialog box shown in Figure 1-10; Mac dialog boxes look a little different).

Another way to open a document is by double-clicking the file itself. If you double-click an Illustrator file when Illustrator isn't running, the program launches for you automatically. (Glad it's not a missile.)

**Figure 1-10:**  
Use the  
Open  
dialog box  
to select  
the file  
you want  
to open.

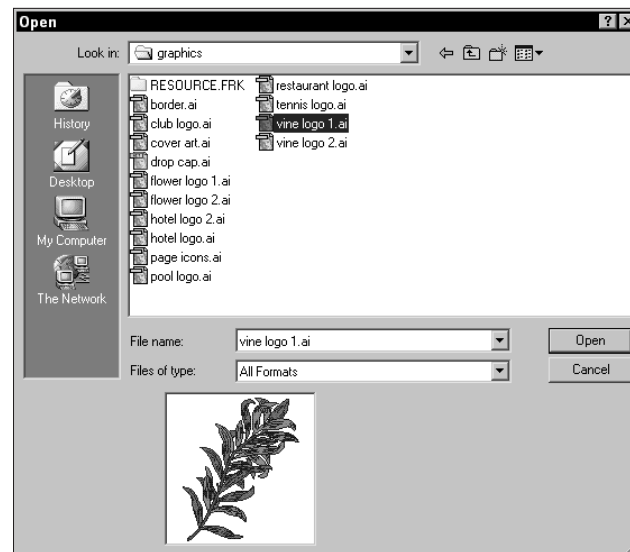

## 28 Part I: Driving People Crazy — Illustrator's Bum Rap

### *Viewing Illustrator Documents*

Illustrator provides versatile options for viewing documents — including controls for zooming, scrolling, and hiding (or showing) certain document features. You can get close-up to the smallest areas of your artwork and make changes so minute that they aren't visible to the human eye — but you feel better knowing that your graphic is microscopically perfect. Or, to get a good feel for your artwork's effect in the real world, view your document at the actual size it prints at. Or you can view your on-screen objects as their “skeletons” of essential points and paths, with no strokes or colors to distract you from the true essence of your artwork. A view of any phase is available, from points-and-paths to perfect printout. Bottom line: You have to see what you're doing to know what you're doing. Illustrator offers that capability.

### *Zooming in and out of artwork*

You can view your artwork at actual size (approximately its size when it prints), much larger, or much smaller. Changing the zoom amount changes only the image's on-screen appearance — not the image's actual size, the way it prints, or its appearance in another application. Zooming is like using binoculars to watch a neighbor violate the bylaws of the homeowners' association. Those unapproved maple saplings (and the sap who's planting them) don't actually change size; you just zoom in on them from a discreet distance.

#### *The Zoom tool*



The Zoom tool is the magnifying glass in the lower-right corner of the Toolbox. When you click the Zoom tool and move it over the document, a plus sign appears in the center of the magnifying glass. Clicking the Zoom tool makes the details of your artwork appear larger in the document window. You can click until you zoom in to 6,400 percent (64 times larger than actual size). Figure 1-11 shows a document viewed at actual size and zoomed in to 400 percent.

The Zoom tool is actually two tools in one. When you hold down the Alt key (Option on the Mac), the magnifying glass contains a minus sign. Holding down the Alt or Option key and clicking your image with the Zoom tool causes your image to appear smaller. You can zoom out as far as 3.13 percent (where everything is really tiny). Figure 1-12 shows the art from Figure 1-11 as it looks at 25 percent of its actual size.

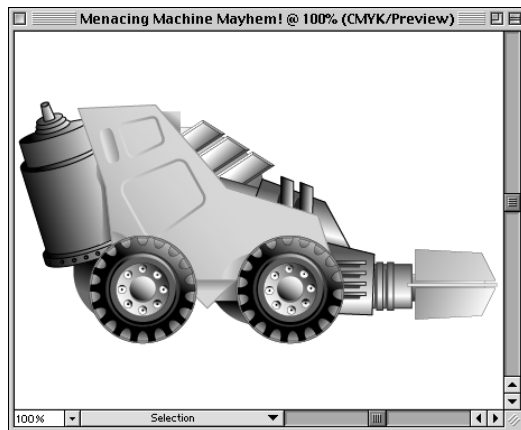

**Figure 1-11:** Two views of the artwork: actual size and zoomed to 400 percent. If you print while zoomed in, the image still prints at actual size.

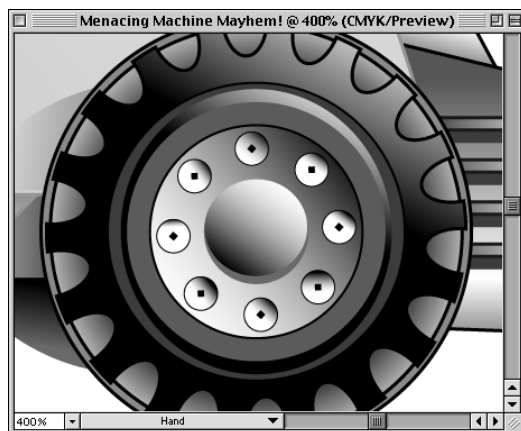

### *Speed zoom ahead*

Zooming is something Illustrator users do often enough to warrant the multitude of keyboard commands associated with this function. In order of usefulness, the following items represent some of the most useful speed-zoom techniques:

- ✔ **Use any tool to Zoom In:** Press Ctrl+Space (⌘+Space on a Mac) and the tool you're using changes to the magnifying glass with a plus sign in it. Click the area where you want to zoom in. After you release the keys, the Zoom tool switches back to the tool you were previously using. This shortcut is *really* handy.

- ✔ **Use any tool to Zoom Out:** Press Ctrl+Alt+Space (⌘+Option+Space on a Mac), and the tool you're using changes to the magnifying glass with a minus sign in it. Click the image to zoom out. After you release the keys, the Zoom tool switches back to the tool you were previously using. This shortcut is as handy as the temporary Zoom In tool.
- ✔ **Go to Actual Size:** Press Ctrl+1 (⌘+1 on a Mac) to return to actual size. You can also double-click the Zoom tool to do this.
- ✔ **Go to Fit In Window view:** Press Ctrl+0 (⌘+0 on a Mac) to zoom to the level at which your page fits into the window. You can also double-click the Hand tool to do this.
- ✔ **Zoom in and out:** Press Ctrl++ (plus) (⌘++ [plus] on a Mac) to zoom in one level or Ctrl+- (minus) (⌘+- [minus] on a Mac) to zoom out one level.
- ✔ **Activate the Zoom In tool:** Press Z to change to the Zoom In tool. If you actually read to the bottom of this list, geekiness from someone you know is starting to rub off on you. I strongly advise taking a few days off — away from your computer (and from said geek).
- ✔ **While Zooming:** Press the spacebar to move around the current marquee (the dotted lines)

**Figure 1-12:**  
The  
artwork  
from  
Figure 1-11  
at 25 percent  
of its actual  
size.

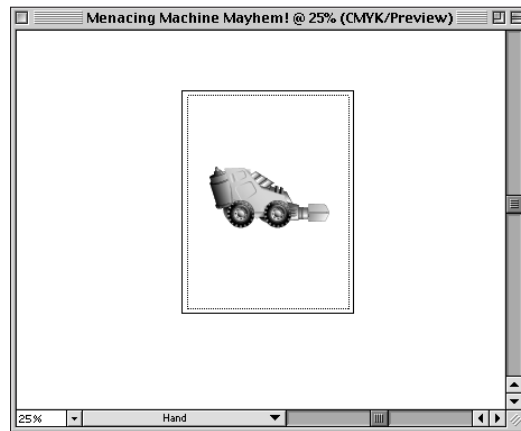

## *Scrolling around your document*

You can use the scroll bars to move around your document, but they limit you to moving horizontally or vertically — and only one of those directions at a time. If you're really cool (and you know you are), you can use the Hand tool to move around your document in any direction.

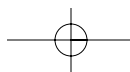

To use the Hand tool, choose it from the Toolbox. Then click and drag anywhere in the document. The artwork moves in the direction you drag. At first, this action may seem slightly awkward — but power corrupts. After a few minutes of pushing your art around, you'll never want to go back to those nasty scroll bars.



You can use any tool as the Hand tool. To change a tool into the Hand tool, hold down the spacebar while you click the tool. Then click and drag just as you would with the Hand tool. Let go of the spacebar, and the tool you were using returns to its original form. This trick works with any tool except the Text tool. (If you try it with that tool, you just type space after space after space.)

## *Looking at the guts of your artwork*

Typically, what you see in your Document window is pretty much what's going to print (the view in Preview mode). However, what you see isn't what the printer and Illustrator look at. Instead, they see all your Illustrator artwork and objects as a series of outlines, placed images, and text (the view in Outline mode). If you want to view your document in this skeletal form, choose View⇨Outline. Outline mode is a great diagnostic tool; it helps you understand how a document was made. Figure 1-13 shows artwork in both Preview and Outline modes. Outline mode also makes it easier to select objects that are very close together.

**Figure 1-13:**  
Art in  
Preview  
mode and  
Outline  
mode.

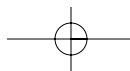
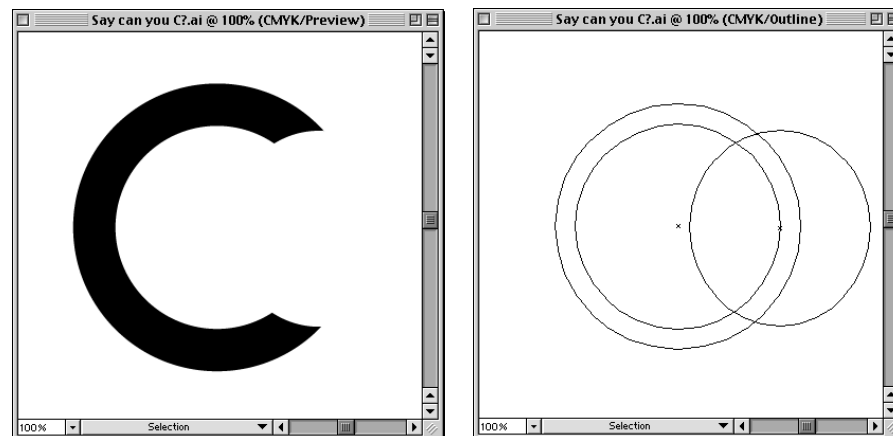



To use a template in Illustrator, select the New from Template option in the Welcome to Adobe Illustrator dialog box that I talked about earlier in the chapter, or choose **File**⇨**New from Template**. The template opens up as an untitled document (don't be concerned about writing over the template; you're actually opening a copy of the original file).

## Saving Illustrator Documents

The instant you accomplish something you like, you should save it. And you should save every few minutes, even if you haven't done something you like, because if you don't, you lose all the work and have to re-create it if you crash, accidentally quit, or accidentally shut off the power supply to your computer. Unlike applications such as Microsoft Word or Adobe InDesign, Illustrator has no auto-save feature. Anything you don't save is lost. Just remember that old TLA (three-letter acronym), SOS: Save Often, Silly! Saving only takes a second, and it saves not only your artwork but also your time and sanity.

To save a document, choose **File**⇨**Save**. If you haven't previously saved the document, the Save As dialog box (shown in Figure 1-15) appears; reward its promptness by naming your file something appropriate, witty, and deep. Or type something hurried-but-meaningful, such as **gasdfoiu** or **jk123**, so you can challenge yourself later to figure out what that **@#!** document is. (Just kidding.)

If you've already saved your document, the Save command updates the existing file. If you're not sure whether you previously saved, look at the title bar. If it reads *Untitled-1*, you probably haven't saved (only someone with a creepy sense of humor would pick *Untitled-1* as a title just to befuddle the rest of us).

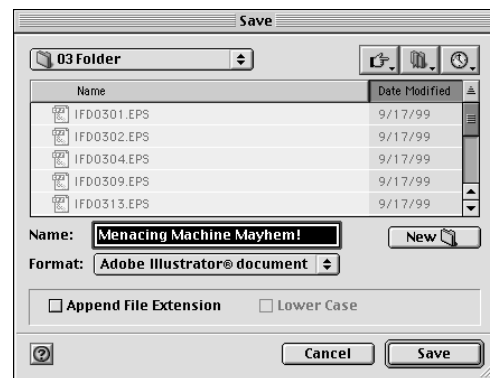

**Figure 1-15:**  
Name your masterpiece in the Save dialog box.

## 34 Part I: Driving People Crazy — Illustrator's Bum Rap

### *Changing Your Mind*

One of Illustrator's most powerful features may be strikingly familiar: Edit⇨Undo gives you a way to take back the goof you just made. But that's so common these days; in Illustrator, Edit⇨Undo is a multiple undo — it makes you the Master of Time! You can take your artwork back through time, step by step, all the way to when you first opened the document! If you make a mistake (or several), just choose Edit⇨Undo (or press ⌘+Z on a Mac, Ctrl+Z with Windows) repeatedly, until you get back to the way things were before they went so wrong. To redo the last thing you undid, select Edit⇨Redo (or press ⌘+Shift+Z on a Mac, Ctrl+Shift+Z with Windows). (A time machine with a reverse gear — way cool.)

Imagine creating with wild abandon — moving points, changing colors and line thicknesses, running filters — because in Illustrator, you can change your mind after the fact. Think of what you could obliterate from time — the misplaced stroke that looks like a bad tattoo, the missed goal that kept your team from the playoffs, the blind date that went so horribly wrong — well, okay, it only works in Illustrator. At least it works somewhere.

You can take a graphic back to the way it was when you first opened it, with one exception: If you close a file and then open it again, you can't go back to anything you did before you closed the file. You can, however, save a file and then go back to things that happened before you saved it — if you left the file open after you saved it. In that case, the only thing that can't be undone is the Save command: You still have a file on your hard drive that exists exactly as it did when you hit Save. This method can be useful if you have to create multiple revisions of the same document.

### *Printing Illustrator Documents*

If your computer is hooked up or networked to a printer, you can print just about anything you create in Illustrator. Before you print, however, make sure that your artwork is within the Page Tiling boundaries (that dotted gray rectangle that shows up when you select View⇨Show Page Tiling). Only items within these boundaries print. The dotted lines on the page indicate the trim area; if your image is outside the dotted lines, it won't print.

To print your artwork, choose File⇨Print. The Print dialog box appears (see Figure 1-16). Click OK; soon a sheet of paper emerges from your printer with your artwork on it.

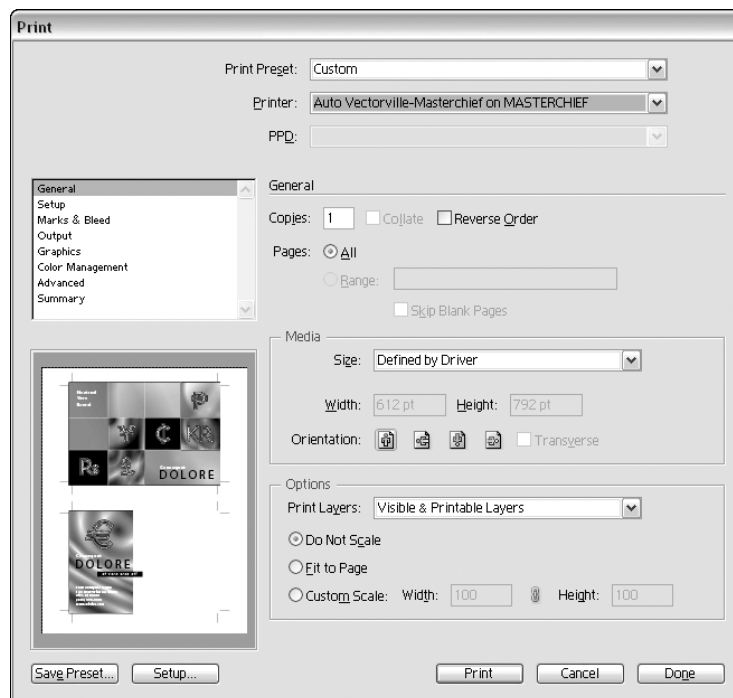

**Figure 1-16:**  
The Print dialog box, updated with lots of funky options for version CS.

## Closing Documents and Quitting Illustrator

To close an Illustrator document, choose **File**⇨**Close**. The document closes without a fuss. If you haven't saved before closing, a dialog box appears, asking whether you want to save changes made to your artwork. To quit Illustrator, choose **File**⇨**Exit** (Windows) or **File**⇨**Quit** (Mac). If you haven't saved before quitting, a dialog box appears and asks whether you want to save your changes. (Consistent good manners — aren't they wonderful?)

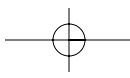

# 36 Part I: Driving People Crazy — Illustrator's Bum Rap \_\_\_\_\_

