1

PETROLEUM REFINING

1.1 PROPERTIES OF PETROLEUM

Petroleum is the most important substance consumed in modern society. It provides not only fuel and energy for transportation but is also used in plastics, paint, fertilizer, insecticide, medicine, and elsewhere. The exact composition of petroleum varies widely from source to source, but the percentage of chemical elements changes over fairly narrow limits. Hydrogen and carbon are the major components, and sulfur, nitrogen, oxygen, and metals are present in relatively lower quantities (Table 1.1). Usually, petroleum or crude oil comes from deep underground, where the vestiges of plants and animals from millions of years ago have been heated and pressurized over time. It is blackish in color and has a characteristic odor that comes from the presence of small amounts of chemical compounds containing sulfur, nitrogen, and metals.

The change in crude oil quality around the world (e.g., heavy petroleum production has been increased in recent years) has obliged crude oil refiners to reconfigure current refineries and to design new refineries specifically to process heavier feedstocks (i.e., blends of various crude oils with elevated amount of heavy petroleum). These new feeds are characterized by high amounts of impurities (sulfur, metals, nitrogen, asphaltenes) and low distillate yields, which make them more difficult than light crude oils to process.

Comparisons of some properties of various crude oils are presented in Tables 1.2 and 1.3. It is clear that light and heavy crude oils have remarkable

Modeling and Simulation of Catalytic Reactors for Petroleum Refining, First Edition.
Jorge Ancheyta.

© 2011 John Wiley & Sons, Inc. Published 2011 by John Wiley & Sons, Inc.

TABLE 1.1. Typical Elemental Composition of Petroleum

Element	Weight Percentage
C	84–87
H	11–14
O	0.1–0.5
N	0.1–2
S	0.5–6
Metals	0–0.1

TABLE 1.2. Range of Properties of Various Types of Petroleum

	Extra-light Crude Oil	Light Crude Oil	Heavy Crude Oil	Extra-Heavy Crude Oil
API gravity	>50	22–32	10–22	<10
Hydrocarbons (wt%)				
Asphaltenes	0–<2	<0.1–12	11–25	15–40
Resins	0.05–3	3–22	14–39	
Oils	—	67–97	24–64	
Impurities (wt%)				
Total sulfur	0.02–0.2	0.05–4.0	0.1–5.0	0.8–6.0
Total nitrogen	0.0–0.01	0.02–0.5	0.2–0.8	0.1–1.3
Ni + V (wppm)	<10	10–200	50–500	200–600

TABLE 1.3. Properties of Various Crude Oils

Crude Oil	Lagrange	Isthmus	Maya	Lloyminster	Athabasca
Country	France	Mexico	Mexico	Canada	Canada
API gravity	43	33.34	21.31	15.0	8.0
Sulfur (wt%)	—	1.46	3.57	—	1.25
Nitrogen (wt%)	—	0.1467	0.32	4.30	7.95
Insolubles in nC_7 (wt%)	4	1.65	11.32	12.9	15.0

differences. Heavy petroleum is characterized by low API gravity, large amounts of impurities, and low distillates yields; light petroleum is of much better quality. In general, the lower the API gravity (i.e., the heavier the crude oil), the higher the impurities content and the lower the distillates yield. Such properties make processing of heavy petroleum different from that used for light crude oil refining. In other words, a refinery capable of processing light petroleum cannot, without changes in some units or even complete reconfiguration, be employed to process 100% heavy petroleum.

TABLE 1.4. SARA Analysis and Physical Properties of Petroleum

		Physical Properties		
		Non-polar	Low density	Low aromaticity
Saturates	{ M a l t e n e s	↓	↓	↓
Aromatics				
Resins				
Asphaltenes				

In general, light crude oil is rich in light distillates, and heavy crude oil, in residuum. However, the petroleum composition may vary with its API gravity and origin. Physical properties and exact chemical composition of crude oil also vary from one source to another. As a guide to chemical composition, Table 1.4 provides qualitative data on saturate, aromatic, resin and asphaltene (SARA) contents in the heavy fractions present in various crude oils. The most complex impurity of petroleum is asphaltene, which consists of condensed polynuclear aromatics containing small amounts of heteroatoms (S, N, O) and traces of nickel and vanadium. Asphaltenes are typically defined as brown and black powdery material produced by the treatment of petroleum, petroleum residua, or bituminous materials with a low-boiling liquid hydrocarbon (e.g., pentane or heptane); and soluble in benzene (and other aromatic solvents), carbon disulfide, and chloroform (or other chlorinated hydrocarbon solvents). Asphaltene molecules are grouped together in systems of up to five or six sheets, which are surrounded by the maltenes (all those structures different from asphaltenes that are soluble in *n*-heptane) and resin.

The properties of petroleum, such as viscosity, density, boiling point, and color, may vary widely, and the ultimate or elemental analysis varies over a narrow range for a large number of samples. Metals have a tendency to concentrate more in the heavier fraction (asphaltene) than in the saturated and aromatic fractions. The higher the asphaltene content in crude oil, the higher the metal content; however, the increase in vanadium concentration is not proportional to that of nickel. Nitrogen and sulfur can be present in traces in light petroleum, but with heavier or extra heavy crude oil, the sulfur and nitrogen contents also increase.

1.2 ASSAY OF CRUDE OILS

It is important to determine the physical and chemical characterizations of crude oil through a crude oil assay, since they are used in different areas in the petroleum refining industry. The most common applications of petroleum assays are:

- To provide extensive detailed experimental data for refiners to establish the compatibility of a crude oil for a particular petroleum refinery
- To anticipate if the crude oil will fulfill the required product yield, quality, and production
- To determine if during refining the crude oil will meet environmental and other standards
- To help refiners to make decisions about changes in plant operation, development of product schedules, and examination of future processing ventures
- To supply engineering companies with detailed crude oil analyses for their process design of petroleum refining plants
- To facilitate companies' crude oil pricing and to negotiate possible penalties due to impurities and other undesired properties

A *crude oil assay* is a compilation of laboratory (physical and chemical properties) and pilot-plant (distillation and product fractionation) data that characterize a specific crude oil. Assay analyses of whole crude oils are carried out by combining atmospheric and vacuum distillation units, which when combined will provide a true boiling-point (TBP) distillation. These batch distillation methods, although taking between 3 and 5 days, allow the collection of a sufficient amount of distillation fractions for use in further testing. The values of the distillation ranges of the distilled fractions are usually defined

TABLE 1.5. Typical Distillation Range of Fractions in Petroleum Assays

TBP Distillation Range (°C)	Distillate
IBP–71	Light straight-run naphtha
71–177	Medium straight-run naphtha
177–204	Heavy straight-run naphtha
204–274	Jet fuel
274–316	Kerosene
316–343	Straight-run gasoil
343–454	Light vacuum gasoil
454–538	Heavy vacuum gasoil
R 538°C+	Vacuum residue

on the basis of their refinery product classifications. The most common distillation ranges used in international assays of crude oils are reported in Table 1.5.

There are various types of assays, which vary considerably in the amount of experimental information determined. Some include yields and properties of the streams used as feed for catalytic reforming (naphtha) and catalytic cracking (gas oils). Others give additional details for the potential production of lubricant oil and/or asphalt. At a minimum, the assay should contain a distillation curve (typically, TBP distillation) for the crude oil and a specific gravity curve.

The most complete assay includes experimental characterization of the entire crude oil fraction and various boiling-range fractions. Curves of TBP, specific gravity, and sulfur content are normal data contained in a well-produced assay. As an example, assays of various Mexican crude oils are presented in Table 1.6. The API gravity of these crude oils ranges from 10 to 33°API. *API gravity* is a measure of the relative density of a petroleum liquid and the density of water (i.e., how heavy or light a petroleum liquid is compared to water). Although, mathematically, API gravity has no units, it is always referred to as being in “degrees.” The correlation between specific gravity (sg) and degrees API is as follows (the specific gravity and the API gravity are both at 60°F):

$$\text{API gravity} = \frac{141.5}{\text{sg}_{60^{\circ}\text{F}}} - 131.5 \quad (1.1)$$

Viscosity must be provided at a minimum of three temperatures so that one can calculate the sample viscosity at other temperatures. The most common temperatures used to determine viscosity are 15.5, 21.1, and 25°C. If viscosities of the sample cannot be measured at those temperatures, the sample needs to be heated and higher temperatures are used, such as in the case of the 10 and 13°API crude oils reported in Table 1.6. Once viscosities at three temperatures are available, a plot of a double logarithm (\log_{10}) of viscosity against the temperature can be constructed, and viscosities at other temperatures can be obtained easily, as shown in Figure 1.1.

The characterization factor (K_{UOP} or K_{Watson}) of the Mexican crude oils reported in Table 1.6 ranges from 11.5 to 12.0. The K factor is not determined experimentally; rather, it is calculated using the following equation (for petroleum fractions):

$$K = \frac{\sqrt[3]{\text{MeABP}}}{\text{sg}_{60^{\circ}\text{F}}} \quad (1.2)$$

where MeABP (in degrees Rankine) is the mean average boiling point of the sample calculated with distillation curve data.

In general, if $K > 12.5$, the sample is predominantly paraffinic in nature, while $K < 10.0$ is indicative of highly aromatic material. The characterization

TABLE 1.6. Assay of Various Mexican Crude Oils

	ASTM Method	Crude Oil				
		10°API	13°API	Maya	Isthmus	Olmecca
Specific gravity, 60°F/60°F	D-1298	1.0008	0.9801	0.9260	0.8584	0.8315
API gravity	D-287	9.89	12.87	21.31	33.34	38.67
Kinematic viscosity (cSt)	D-445					
At 15.5°C		—	—	299.2	16.0	5.4
At 21.1°C		—	—	221.6	12.5	4.6
At 25.0°C		—	19,646	181.4	10.3	4.1
At 37.8°C		—	5,102	—	—	—
At 54.4°C		7,081	1,235	—	—	—
At 60.0°C		4,426	—	—	—	—
At 70.0°C		2,068	—	—	—	—
Characterization factor, K_{UOP}	UOP-375	11.50	11.60	11.71	11.95	12.00
Pour point (°C)	D-97	+12	0	—	-33	-39
Ramsbottom carbon (wt%)	D-524	20.67	16.06	10.87	4.02	2.10
Conradson carbon (wt%)	D-189	20.42	17.94	11.42	4.85	2.76
Water and sediments (vol%)	D-4007	1.40	0.10	0.20	<0.05	<0.05
Total sulfur (wt%)	D-4294	5.72	5.35	3.57	1.46	0.99
Salt content (PTB)	D-3230	744.0	17.7	15.0	4.1	3.9
Hydrogen sulfide (mg/kg)	UOP-163	—	—	—	44	59
Mercaptans (mg/kg)	UOP-163	—	—	—	65	75
Total acid number (mg KOH/g)	D-664	0.48	0.34	0.30	0.61	0.46
Total nitrogen (wppm)	D4629	5650	4761	3200	1467	737
Basic nitrogen (wppm)	UOP-313	1275	1779	748	389	150
n_C insolubles (wt%)	D-3279	25.06	18.03	11.32	1.65	0.68
Toluene insolubles (wt%)	D-4055	0.41	0.20	0.11	0.09	0.11
Metals (wppm)	Atomic absorption					
Nickel		94.2	83.4	53.4	8.9	1.6
Vanadium		494.0	445.0	298.1	37.1	8.0
Total		588.2	528.4	351.5	46.0	9.6
Chloride content (wppm)	D-808	86	10	4	10	9

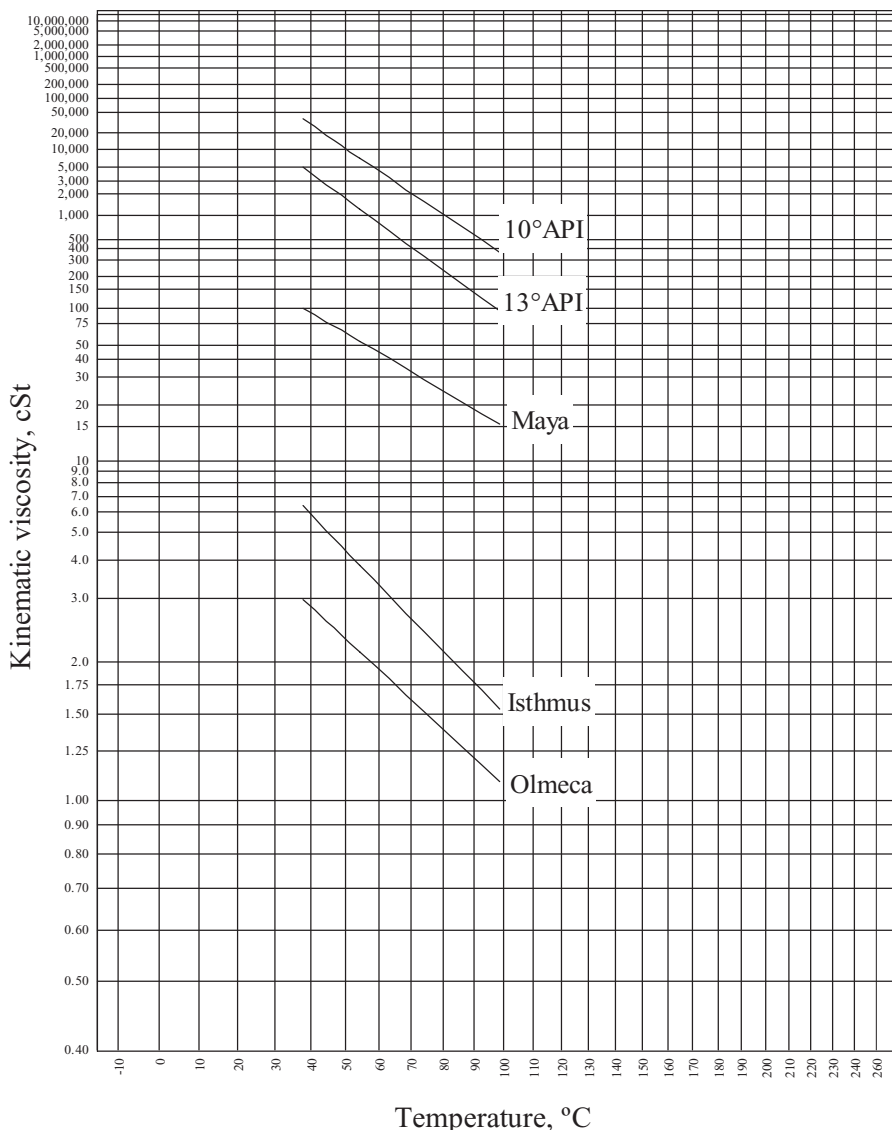
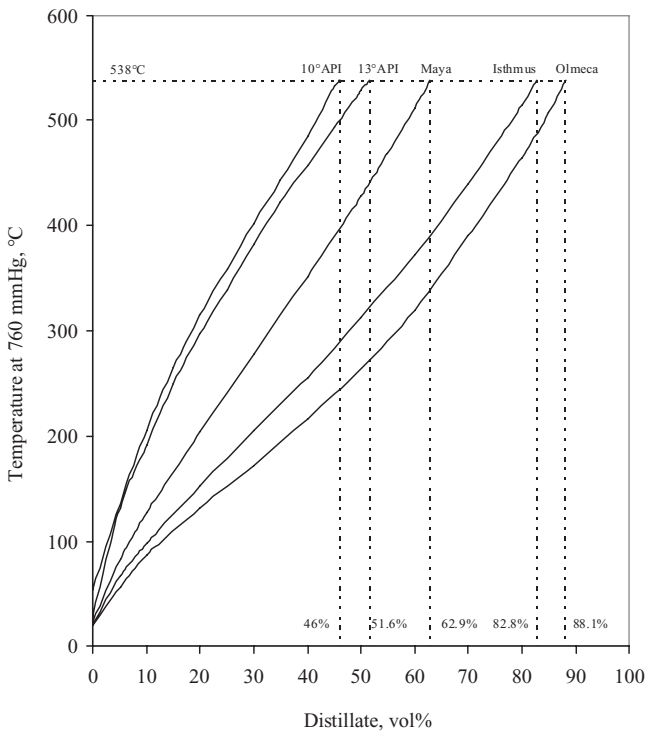

Figure 1.1. Kinematic viscosities of several Mexican crude oils.

factor thus provides a means for roughly identifying the general origin and nature of petroleum solely on the basis of two observable physical parameters, sg and MeABP. More detailed relationships of the *K* factor to the nature of the sample are given in Table 1.7. The characterization factor has also been related to other properties (e.g., viscosity, aniline point, molecular weight, critical temperature, percentage of hydrocarbons), so it can be estimated using a number of petroleum properties.

TABLE 1.7. Relationship of Type of Hydrocarbon to the Characterization Factor

<i>K</i> Factor	Type of Hydrocarbon
12.15–12.90	Paraffinic
11.50–12.10	Naphthenic–paraffinic
11.00–11.45	Naphthenic
10.50–10.90	Aromatic–naphthenic
10.00–10.45	Aromatic

**Figure 1.2.** True boiling-point curve of various Mexican crude oils.

Asphaltenes, which are generally reported as *n*-heptane insolubles, are, strictly speaking, defined as the weight percentage of *n*-heptane insolubles (HIs) minus the weight percentage of toluene insolubles (TIs) in the sample (wt% of asphaltenes = wt% of HI – wt% of TI). For the crude oils given in Table 1.6, their asphaltene contents are 24.65, 17.83, 11.21, 1.56, and 0.57 wt% for the 10°API, 13°API, Maya, Isthmus, and Olmeca crude oils, respectively.

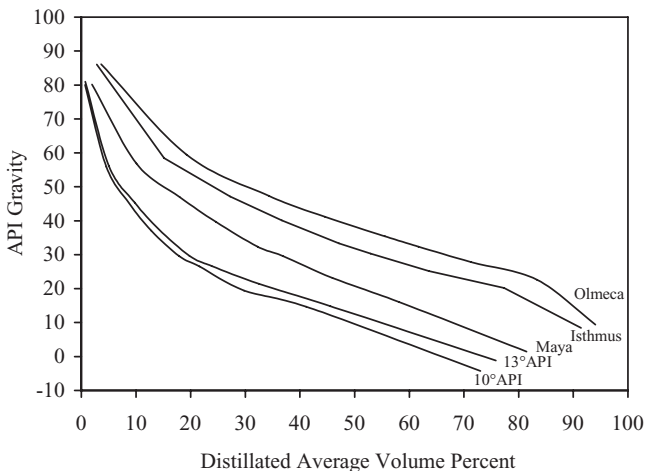

Figure 1.3. API gravity of distillates versus average volume percentage.

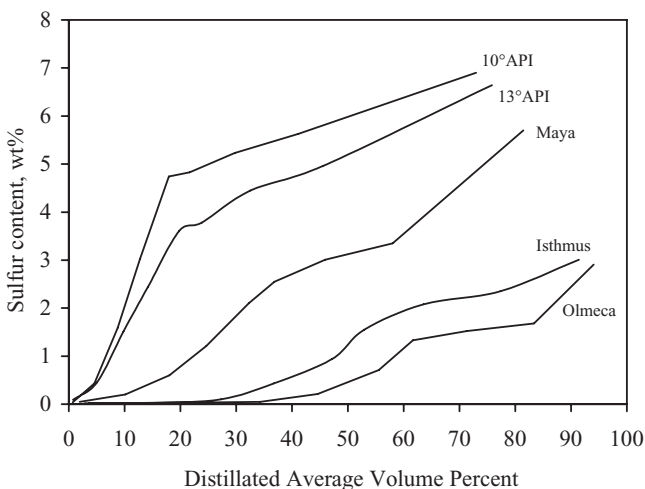

Figure 1.4. Sulfur content of distillates versus average volume percentage.

TBP distillations for Mexican crude oils are presented in Figure 1.2. It is clear that light crude oils that have high API gravity values present also the highest amounts of distillates [e.g., Olmecca crude oil (38.67° API) has 88.1 vol% distillates, whereas the 10°API has only 46 vol% distillates]. Figures 1.3 and 1.4 illustrate plots of API gravity and the sulfur content of distillates against the average volume percentage of distillates of the various crude oils. Distillates of heavier crude oils have lower API gravity and a higher sulfur content than those obtained from light crude oils.

1.3 SEPARATION PROCESSES

1.3.1 Crude Oil Pretreatment: Desalting

Desalting is the first separation process that takes place at the front end of a petroleum refinery (i.e., prior to atmospheric distillation; Figure 1.5). Its primary objective is to prevent corrosion and fouling of downstream lines and equipment by reducing the oil's salt content significantly. Desalting is normally considered a part of the crude distillation unit since heat from some of the streams in the atmospheric distillation is used to heat the crude in the desalting process. The most common salts in crude oil are sodium, calcium and magnesium chlorides ($\text{NaCl} \sim 70$ to $80\text{wt}\%$, $\text{CaCl}_2 \sim 10\text{wt}\%$, and $\text{MgCl}_2 \sim 10$ to $20\text{wt}\%$), which are in the form of crystals or ionized in the water present in the crude. If salt is not removed, the high temperatures present during crude oil refining could cause water hydrolysis, which in turn allows the formation of hydrochloric acid (HCl), provoking serious corrosion problems in the equipment. Part of the salt that has not been removed can also cause fouling problems in pipes, heat transfer equipment, and furnaces. Deactivation of catalysts (e.g., the zeolite-type catalysts used in fluid catalytic cracking) may be enhanced by the metals in salts, particularly sodium. Typically, the maximum salt content allowed in the feed to crude distillation units is 50PTB (pounds of salt per thousand barrels of crude oil).

Desalting consists of washing the crude oil with water and caustic (NaOH) so that the salts can be diluted in water and washed from the organic phase.

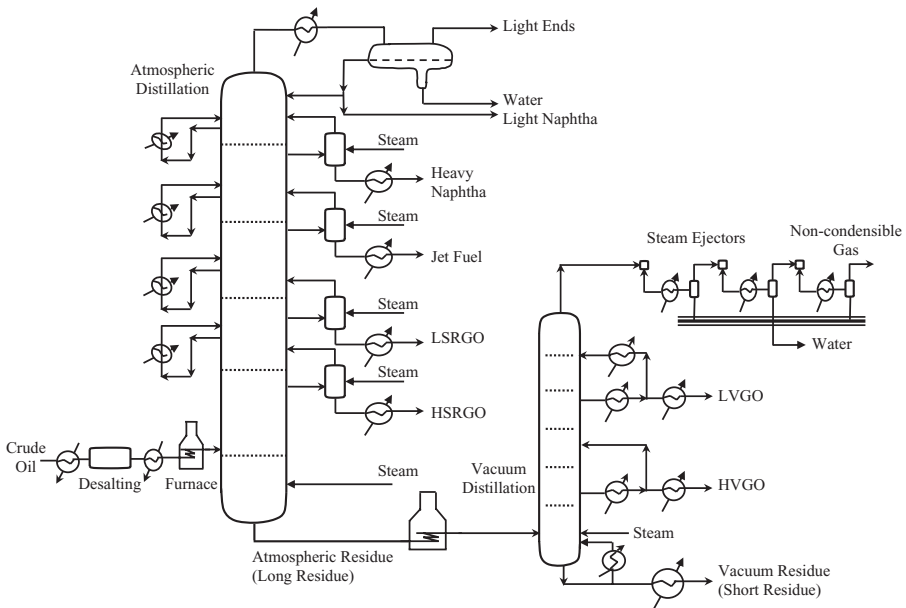
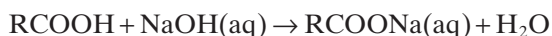
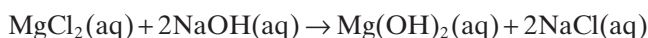

Figure 1.5. Desalting and atmospheric and vacuum distillations of crude oil.

Some of the mixed water forms an emulsion that must be demulsified to separate water from oil. Emulsifiers are present in the form of clay, metallic salts, and asphaltenes, whose contents are higher in heavy crude oils. By this means, dissolved salts are removed and acid chlorides (MgCl_2 and CaCl_2) are converted to a neutral chloride (NaCl), which prevents the formation of hydrochloric acid when residual chlorides enter the refinery. Some naphthenic acids are also converted to their respective carboxylate salts and removed as part of the aqueous effluent.

The reactions occurring during desalting are



The carboxylate salts produced during the conversion of naphthenic acids are surface active and can form stable solutions. This process is controlled by coalescing and decanting the suspended water droplets, which possess an electric charge, under the influence of an electric field (~ 700 to 1000 V/cm). This electric field destabilizes the electric array in the droplets.

Desalting can be carried out in a single stage (dehydration efficiency of $\sim 95\%$) or in two stages (dehydration efficiency of $\sim 99\%$). The dehydration efficiency can be compared with the desalting efficiency, as most of the salt passes from the organic phase into the water phase if mixing is good. The decision as to whether to use a single or a double stage depends on the requirements of the refinery. Typical desalters have two electrodes which generate an electric field within the emulsion, causing the droplets to vibrate, migrate, and collide with each other and coalesce. Voltage ($16,000$ to $30,000 \text{ V ac}$) is what makes coalescence possible, so that the larger drops settle under the effect of gravity. Electric current does not participate in this process.

The principal steps during desalting are:

- Preheating of water and oil and mixing in a 1:20 ratio.
- Addition of a demulsifier substance (~ 0.005 to 0.01 lb/bbl).
- Mixing in a valve (5 to 20 psi pressure drop). The better the mixing, the higher the salt removal, so that the salt content in oil is washed with the water and a water–oil emulsion is formed.
- Entrance of the emulsion into the desalter, where an intense electric field is present. The desalter operates at temperatures between 95 and 150°C . The oil leaves the desalter.

Apart from removing salt, electrostatic desalting also eliminates water and suspended solids in crude oil. Water removal is important to reduce pumping costs and to avoid vaporization when the water is passing through the preheater train (i.e., the water heat of vaporization reduces the crude preheater capacity). Otherwise, due to the high pressure, it causes disturbances and vibrations and eventually plant shutdown. Elimination of suspended solids is necessary

to avoid their going all the way through the plant to be expelled with the flue gas. This causes flue gas opacity that does not meet environmental requirements, resulting in mandatory additional treatment prior to being expelled.

1.3.2 Atmospheric Distillation

The main separation step in any crude oil refinery is atmospheric or primary distillation. Atmospheric distillation fractionates the crude oil into various distillates, fractions, or cuts of hydrocarbon compounds based on molecular size and boiling-point range [e.g., light ends, propane, butanes, straight-run naphthas (light and heavy), kerosene, straight-run gas oils (light and heavy), and atmospheric residue] (Figure 1.5). The term *atmospheric distillation* is used because the unit operates slightly above atmospheric pressure. Separation is carried out in a large tower, which contains a number of trays where hydrocarbon gases and liquids interact. The heated desalted crude enters the fractionation tower in a lower section called the *flash zone*. The unvaporized portion of the crude oil leaves the bottom of the tower via a steam stripper section, while the distillate vapors move up the tower countercurrent to a cooler liquid reflux stream. The cooling and condensing of the distillation tower overhead is provided partially by exchanging heat with the incoming crude oil and partially by either an air- or a water-cooled condenser. Additional heat is removed from the distillation column by a pump-around system, which is simply an internal condenser that ensures a continued reflux stream flow. The overhead distillate fraction from the distillation column is naphtha, which is allowed to leave the top of the tower to be condensed and collected in the overhead drum. A portion of this stream is returned as reflux, while the rest is delivered to the light-end processes for stabilizing and further distillation. The other fractions removed from the side of the distillation column [i.e., from selected trays (draw-off trays)] at various points between the column top and bottom are jet fuel, kerosene, light gas oil, and heavy gas oil, which are steam stripped, cooled by exchanging heat with the incoming crude oil, and sent to other treatment areas and/or to storage. The heavier material (i.e., atmospheric residue oil) is withdrawn from the bottom of the tower.

Each stream is converted further by changing the size and structure of the molecules through cracking, reforming, and other conversion processes. The converted products are then subjected to various treatment and separation processes to remove undesirable constituents or impurities (e.g., sulfur, nitrogen) and to improve product quality (e.g., octane number, cetane number). Atmospheric distillation is a crucial step, since it routes the molecules to the appropriate conversion units in the refinery. The cut point of the atmospheric residue depends on the prevailing fuel specifications and crude slate used. The atmospheric residue leaves the bottom of the unit and is processed further in the vacuum distillation unit.

It is important not to subject crude oil to temperatures above 370 to 380°C because the high-molecular-weight components will undergo thermal cracking

and form coke. The coke, by operating the distillation units at a high temperature, would result in plugging the tubes in the furnace that heats the crude oil fed to the distillation column. Plugging would also occur in the piping from the furnace to the distillation column as well as in the column itself.

1.3.3 Vacuum Distillation

The main objective of a *vacuum* or *secondary distillation unit* is to recover additional distillates from atmospheric residue (long residue). The atmospheric residue is distilled to provide the heavy distillate streams used to produce lube oil or as feed to conversion units. The primary advantage of vacuum distillation is that it allows for distilling heavier materials at lower temperatures than those that would be required at atmospheric pressure, thus avoiding thermal cracking of the components. Vacuum distillation is often integrated with the atmospheric distillation as far as heat transfer is concerned. This unit's integration is called *combined distillation*. Generally, the atmospheric residue is received hot from the atmospheric distillation and is sent to the fired heater of the vacuum unit. The vacuum distillation unit is operated at a slight vacuum, which is most often achieved by using multiple stages of steam jet ejectors (absolute pressures as low as 10 to 40 mmHg). This allows the hydrocarbons to be separated at lower temperatures and prevents undesirable chemical reactions.

Atmospheric residue is separated into light vacuum gas oil, heavy vacuum gas oil, and vacuum residue (Figure 1.5). The vacuum gas oils are sent to the catalytic cracking unit for further processing, while the vacuum residue (short residue) can be used as feedstock for further upgrading (i.e., coking, hydrocracking, etc.) or as a fuel component.

Vacuum distillation follows very much the same pattern as that of atmospheric distillation. One difference is that neither the vacuum residue that leaves the bottom of the tower nor the sidestreams are steam stripped. The technology of vacuum distillation has developed considerably in recent decades. The main objectives have been to maximize the recovery of valuable distillates and to reduce the energy consumption of the units. The vacuum distillation column internals must provide good vapor–liquid contact while maintaining a very low pressure increase from the top of the column to the bottom. Therefore, the vacuum column uses distillation trays only where withdrawing products from the side of the column. Most of the column uses packing material for the vapor–liquid contact because such a packing has a lower pressure drop than that of distillation trays. This packing material can be either structured sheet metal or randomly dumped packing such as Raschig rings.

1.3.4 Solvent Extraction and Dewaxing

Since distillation separates petroleum products into groups only by their boiling-point ranges, impurities such as sulfur and nitrogen may remain. Solvent refining processes, including solvent extraction and solvent dewaxing,

usually remove these undesirables at intermediate refining stages or just before sending the product to storage.

Solvent extraction processes are employed primarily for the removal by dissolution or precipitation of constituents that would have an adverse effect on the performance of the product in use. An important application is the removal of heavy aromatic compounds from lubricating oils. Removal improves the viscosity–temperature relationship of the product, extending the temperature range over which satisfactory lubrication is obtained. The usual solvents for the extraction of lubricating oil are phenol, furfural, and cresylic acid. Solvents used less frequently are liquid sulfur dioxide, nitrobenzene, and 2,2'-dichloroethyl ether.

Solvent dewaxing is used to remove wax from either distillate or residua at any stage in the refining process. The general steps of solvent dewaxing processes are (1) mixing the feedstock with a solvent, (2) precipitating the wax from the mixture by chilling, and (3) recovering the solvent from the wax and dewaxed oil for recycling by distillation and steam stripping. Usually, two solvents are used: toluene to dissolve the oil and maintain fluidity at low temperatures, and methyl ethyl ketone (MEK) to dissolve a little wax at low temperatures and act as a wax-precipitating agent. Other solvents that are sometimes used are benzene, methyl isobutyl ketone, propane, petroleum naphtha, ethylene dichloride, methylene chloride, and sulfur dioxide. In addition, a catalytic process is used as an alternative to solvent dewaxing.

1.3.5 Deasphalting

The separation of vacuum residue into fractions by distillation without decomposition is not practiced commercially since it is very difficult and expensive. *Solvent deasphalting* (SDA), a nondestructive liquid–liquid extraction process, is preferred to achieve this goal, whereby the last of the molecules that can be refined to valuable products are extracted from the vacuum residue. SDA is a molecular-weight-based separation process member of the family of carbon rejection technologies, which has been used for more than 50 years to separate heavy fractions of crude oil beyond the range of economical commercial distillation. Use of SDA has been reported for production of lube oil feedstocks from vacuum residue using propane as a solvent, for preparation of feedstocks for catalytic cracking, hydrocracking, and hydrodesulfurization units, as well as for the production of specialty asphalts. In most of these conversion units the performance of the catalyst is greatly affected by the presence of heavy metals and the high Conradson carbon content of the residue feed, which are concentrated in the asphaltene molecules, so that removing asphaltenes also eliminates these impurities.

Deasphalting is an extraction process that separates the residue into several fractions on the basis of relative solubility in a solvent (normally, a light hydrocarbon such as propane, butane, pentane, or hexane). The yield of deasphalted oil increased with increases in the molecular weight of the solvent, but its quality decreases. SDA produces a low-contaminant deasphalted oil (DAO)

rich in paraffinic-type molecules and a pitch product rich in aromatic compounds and asphaltenes containing, of course, the majority of the feed impurities. The DAO produced has a lower carbon residue and metals content than that of the untreated oil, but SDA is not as effective in lowering the sulfur or nitrogen content in DAO.

1.3.6 Other Separation Processes

Gas and Liquid Sweetening *Gas sweetening* is a process used to remove hydrogen sulfide and carbon dioxide (acid gases) from refinery gas streams. The acid gases are highly concentrated in H_2S , which comes mainly from hydrotreating processes within the refinery. Acid gases are required to be removed:

- For environmental reasons. If H_2S and CO_2 are not removed, they combine with the atmosphere to form very dilute sulfuric acid, and carbonic acid, respectively, which are considered injurious to personal health.
- To purify gas streams for further use in a process. Acid gases cause excessive corrosion to metals.

Gas sweetening is commonly carried out using an amine gas-treating process which uses aqueous solutions of various alkanolamines: MEA, monoethanolamine; DEA, diethanolamine; MDEA, methyldiethanolamine; DIPA, diisopropylamine; DGA, aminoethoxyethanol or diglycolamine—MEA, DEA, and MDEA being the most commonly used amines. Among them, MEA has become the preferred amine commercially, due to its high acid gas absorbency. Apart from amine gas treating, hot potassium carbonate (Benfield) is another process that can be used for acid gas sweetening. There are also other alternatives, based on physical solvent processes (e.g., Sulfinol, Selexol, Propylene Carbonate, Rectisol) and dry adsorbent processes (e.g., molecular sieve, activated charcoal, iron sponge, zinc oxide).

A typical amine gas-treating process consists of the following steps:

- Passing the acid gas stream through an absorber unit (contactor), in which the downflowing amine solution absorbs H_2S and CO_2 from the upflowing gas to produce an H_2S -free gas called *sweetened gas* and an amine solution rich in absorbed acid gases.
- Sending the rich amine to a regenerator, which consists of a stripper with a reboiler, to produce regenerated or lean amine.
- Cooling and recycling the regenerated amine for reuse in the absorber.
- Sending the H_2S -rich stripped gas stream to a Claus process to convert it into elemental sulfur, which is produced by burning H_2S with a controlled airstream. This gas stream can also be sent to a WSA process to recover sulfur as concentrated sulfuric acid.
- Washing the sweetened gas with water to remove any entrained amine before leaving the top of the contactor.

In the case of *liquid sweetening*, there are different treating processes, aiming at the elimination of unwanted sulfur compounds (hydrogen sulfide, thiophene, and mercaptans). The crude oil liquid fractions that require sweetening either at an intermediate stage in the refining process or just before sending them to storage are gasoline, jet fuel, and sometimes kerosene, to improve color, odor, and oxidation stability. Acids, solvents, alkalis, and oxidizing and adsorption agents are the most common materials used for liquid sweetening. Selection of the treatment method depends on:

- The properties of the liquid distillate and the origin of the crude
- The amounts and types of impurities in the liquid distillate
- The degree of impurities removal achieved by the treating method
- The specification of the final product

LPG, naphthas, jet fuel, and kerosene have a sulfur content, predominately in the form of mercaptans, that can be removed by converting them to liquid hydrocarbon disulfides. The most common process used to achieve this target is Merox (mercaptan oxidation), licensed by the UOP. This process requires an alkaline environment provided by either a strong base (commonly aqueous solution of sodium hydroxide) or a weak base (ammonia). Although the Merox process is more economical than catalytic hydrodesulfurization, some refiners still select it to remove sulfur compounds from debutanized naphtha.

Sour Water Treatment In general, the term *sour water* is applied to any water that contains hydrogen sulfide, although it may also contains ammonia, phenol, and cyanide. It is also important to eliminate selenium since it causes mutagenic effects in wildlife. Prior to disposal, sour water must be treated to remove these contaminants. The various sources of sour water in a refinery are:

- Effluent water from the crude unit overhead condenser
- Water phase from the desalter
- Condensed water from the vacuum unit's hot well
- Water condensate from the hydrotreater product steam strippers

Sour water is typically treated by a stripping unit with steam by means of which H_2S and NH_3 are released at the top of the stripping tower. The H_2S -free water is treated in a biological wastewater treatment plant where the remaining ammonia is nitrified and then denitrified. Due to the physics and chemistry of H_2S treatment systems, removal amounts of ammonia, selenium, phenol, salts, and other constituents are lower than that of hydrogen sulfide. In a typical stripping unit, the sour water is fed on to the top tray of the tower while steam is introduced below the bottom tray, which lends itself to tray-by-tray mass and heat transfer. The sour water stripping unit is almost always located in the process area of the refinery and can be a single tower with no reflux or a single trayed tower with an overhead reflux stream.

Other processes for treatment of sour water are: caustic/acid neutralization, caustic oxidization, and oil removal by settling.

1.4 UPGRADING OF DISTILLATES

The main objective of a petroleum refinery is the production of fuels (e.g., gasoline, diesel). Straight-run distillates cannot be used directly as fuels since they possess high amounts of impurities and octane and cetane numbers that are not appropriate for gasoline and diesel engines. These straight-run distillates need treatment to make them suitable for fuel production, which is carried out in various refining processes, as illustrated in Figure 1.6. A brief description of the fundamentals of the various processes used for fuels production is presented in this section. More details on the most important refining processes are given in subsequent chapters.

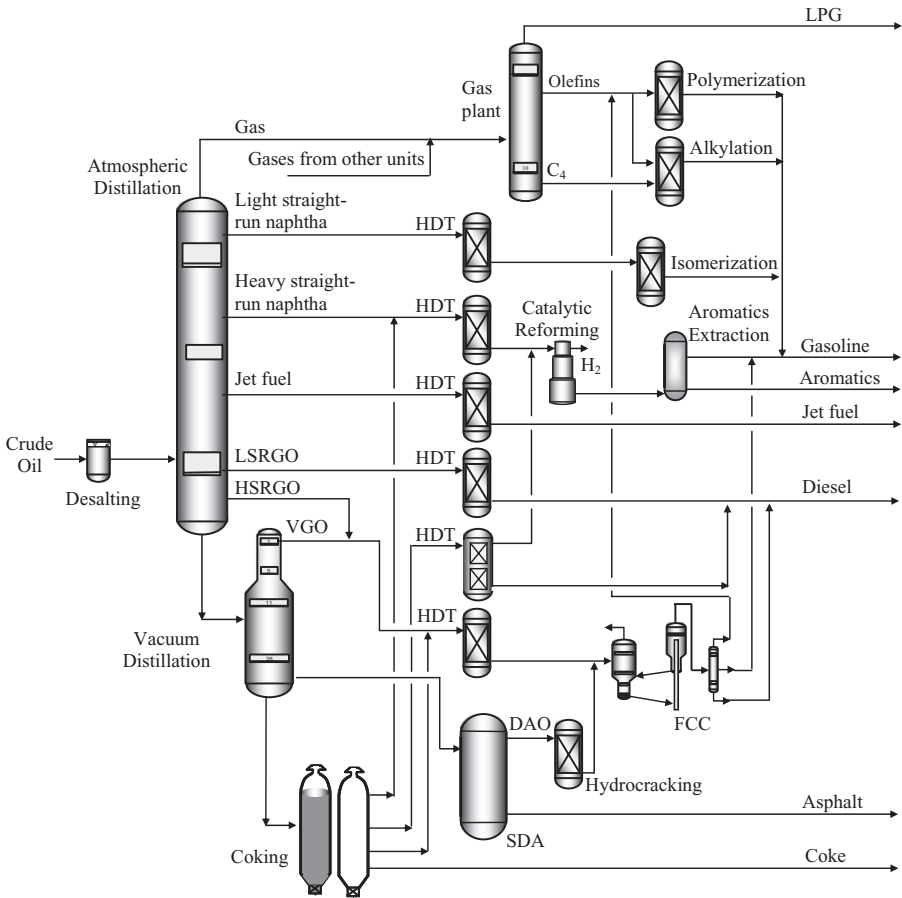

Figure 1.6. Typical process scheme of a petroleum refinery.

1.4.1 Catalytic Reforming

Catalytic reforming is used to convert low-octane straight-run naphtha into high-octane gasoline, called *reformate*, and to provide aromatics (BTX: benzene, toluene, and xylene) for petrochemical plants. The reformate has higher aromatic and cyclic hydrocarbon contents. The main reactions occurring in catalytic reforming are:

- Dehydrogenation of naphthenes to aromatics
- Isomerization of paraffins to branched-chain structures
- Isomerization of naphthenes
- Dehydrocyclization of paraffins and olefins to aromatics
- Hydrocracking of high-boiling hydrocarbons to low-molecular-weight paraffins (hydrocracking of paraffins is undesirable due to increased light ends made)

The objective of these reactions is to restructure and crack some of the molecules present in the feed to produce a product with hydrocarbons that have more complex molecular shapes, whose overall effect is the production of a reformate with a higher octane number than that of the feed. Apart from producing high-octane gasoline, catalytic reforming also produces very significant amounts of hydrogen gas as a by-product, which is released during catalyst reaction and is used in other processes within the refinery (e.g., catalytic hydrotreating and hydrocracking).

A typical catalytic reforming process includes the following steps (Figure 1.7):

- Mixing the feed (naphtha) with recycle hydrogen, heating, and passing through a series of catalytic reactors. The feed must be almost free of sulfur, since even in extremely low concentrations, it poisons the noble metal catalysts (platinum and rhenium) used in the catalytic reforming units.
- Since most of the reactions are highly endothermic, each reactor effluent is reheated before entering the following reactor.
- The effluent from the final reactor is separated into hydrogen-rich gas and reformate, and the hydrogen is recycled or purged for using in other processes. Hydrogen recycle reduces the formation of carbon.
- Reformate product is sent to gasoline blending.

1.4.2 Isomerization

Isomerization is an ideal choice to produce a gasoline blending component from light paraffins. The objective of isomerization is to convert low-octane *n*-paraffins to high-octane *i*-paraffins by using a chloride-promoted fixed-bed reactor. The main steps of a typical isomerization process are (Figure 1.8):

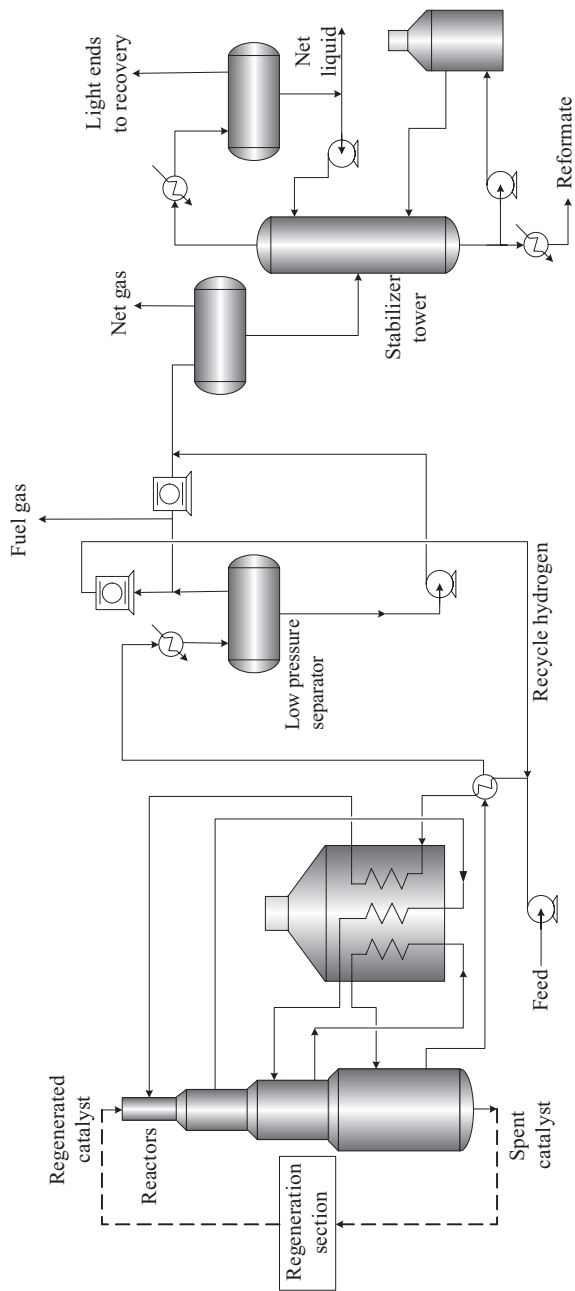

Figure 1.7. Typical process scheme of a catalytic reforming unit.

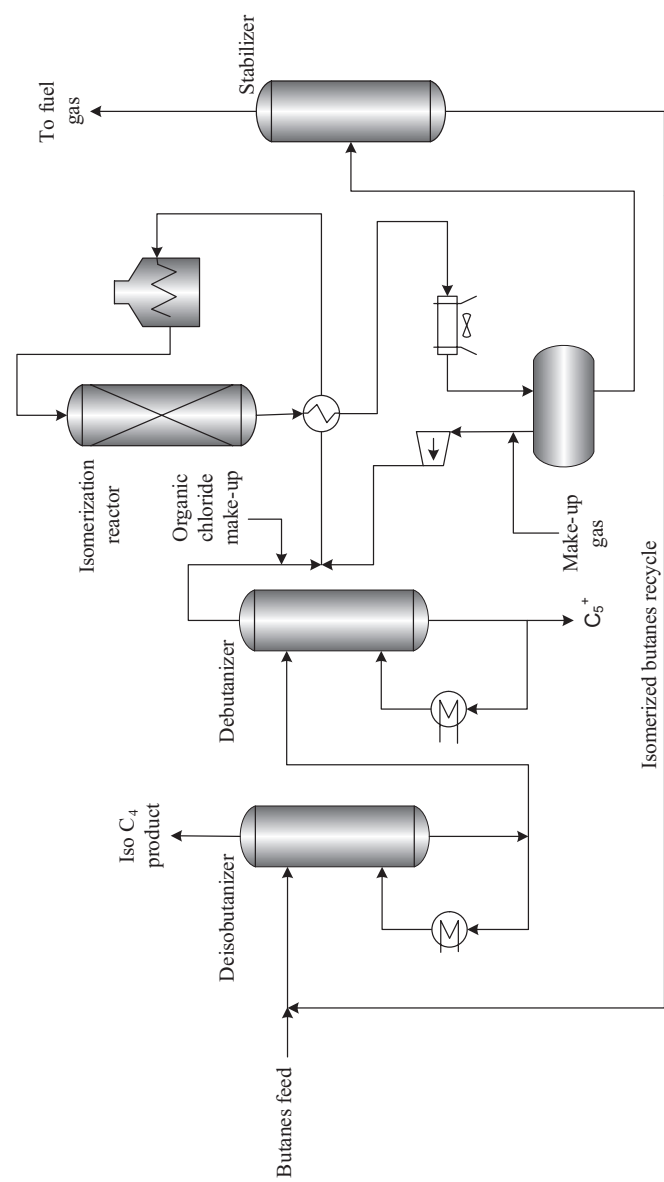

Figure 1.8. Typical process scheme of an isomerization unit.

- Drying the previously desulfurized feed and hydrogen in fixed beds of solid desiccant prior to mixing together
- Heating the mixed feed and passing it through a hydrogenation reactor to saturate olefins to paraffins and to saturate benzene
- Cooling the hydrogenation effluent and passing it through an isomerization reactor, where the isomerization reaction takes place in the catalyst bed
- Cooling the final effluent first by heat exchange with the incoming feed and then by water or air cooling
- Separating the cooled effluent into hydrogen and a liquid stream
- Sending the liquid stream to a reboiled stripper column, where a debutanized isomerate liquid leaves as the bottom product, and the butanes and lighter components leave at the top
- Partially condensing to the gas stream provide reflux to the column and a liquid product rich in butanes and propane (LPG)
- When it leaves the stripper condenser drum, sending the uncondensed overhead to the fuel gas.
- Sending the debutanized isomerate as a product for gasoline blending

As result of the isomerization reactions, highly branched, high-octane paraffinic blending components are obtained, which by themselves can satisfy the strictest gasoline environmental requirements. However, production of this isomerate is low, and other streams for gasoline blending are still necessary. Isomerization of *n*-butane is also one source for the isobutane required in alkylation.

1.4.3 Alkylation

The objective of the *alkylation* process is to combine light olefins (primarily a mixture of propylene and butylene) with isobutane to form a high-octane gasoline (highly branched C₅–C₁₂ *i*-paraffins), called *alkylate*. The major constituents of alkylate are isopentane and isooctane (2,2,4-trimethyl pentane), the latter possessing an octane number of 100. Among all refinery processes, alkylation is a very important process that enhances the yield of high-octane gasoline. The reaction occurs in the presence of a highly acidic liquid catalyst (HF: hydrofluoric acid or H₂SO₄: sulfuric acid). As a consequence of the environmental problems associated with the use of these liquid catalysts, solid acid catalysts have also been proposed, having as a major problem rapid deactivation due to coke formation.

The main steps of a typical hydrofluoric alkylation unit are (Figure 1.9):

- Mixing the olefins coming from fluid catalytic cracking process with isobutane and feeding the mixture to the reactor where the alkylation

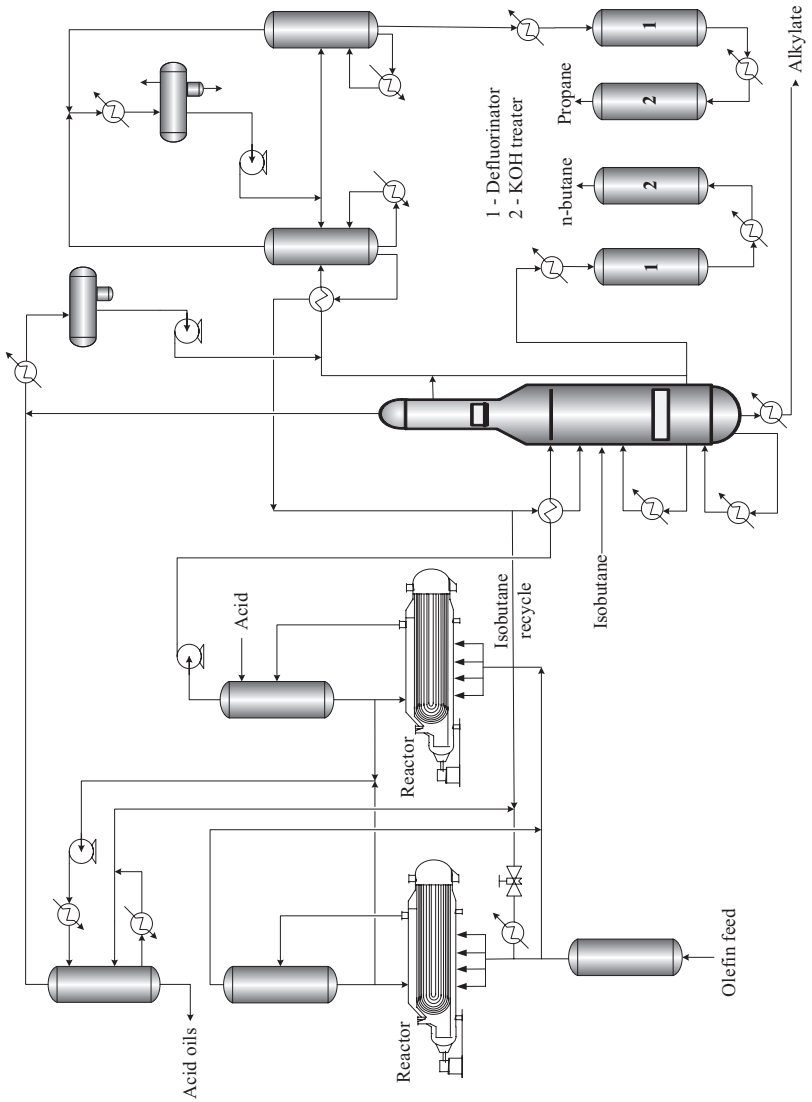

Figure 1.9. Typical process scheme of an alkylation unit.

reaction occurs. Prior to mixing, the olefin feed needs pretreatment to remove H_2S and mercaptans.

- Separation of the free HF from the hydrocarbons in an acid settler and recycling the acid back to the reactor.
- Regeneration of part of the HF to remove acid oils formed by feed contaminants or hydrocarbon polymerization.
- Sending the hydrocarbons from the acid settler to the de-isobutanizer, where propane and isobutane are separated from *n*-butane and alkylate.
- Fractionation of propane from isobutane. Isobutane is then recycled to the reactor.
- *n*-Butane and alkylate are defluorinated in a bed of solid adsorbent and fractionated as separate products. Propane and *n*-butane are nonreactive hydrocarbons.

The function of the acid catalyst is to protonate the olefin feed to produce reactive carbocations, which alkylate isobutane. Alkylation reaction is very fast with 100% olefin conversion. It is important to keep a high isobutene-to-olefin ratio to prevent side reactions, which can produce a lower-octane product. This is the reason that alkylation units have a high recycle of isobutane.

1.4.4 Polymerization

The objective of a *polymerization* unit is to combine or polymerize the light olefins propylene and butylene into molecules two or three times their original molecular weight. The feed to this process consists of light gaseous hydrocarbons (C_3 and C_4) produced by catalytic cracking, which are highly unsaturated. The polymer gasoline produced has octane numbers above 90. Although the amount of polymer gasoline is very small, it is an important part of a refinery since the polymerization process increases the yield of gasoline possible from gas oil. For example, the numbers of barrels of polymer gasoline per barrel of olefin feed is about half those of alkylate, but capital and operating costs are much lower in polymerization because it operates at low pressures compared with alkylation. The polymerization reaction consists of passing the C_3 – C_4 hydrocarbon stream with a high proportion of olefins through a reactor containing a phosphoric acid-supported catalyst, where the carbon–carbon bond formation occurs.

Polymerization comprises the following main steps (Figure 1.10):

- Contacting the feed with an amine solution to remove H_2S and washing with caustic to remove mercaptans
- Scrubbing with water to remove any caustic or amines
- Drying by passing through a silica gel or molecular sieve bed

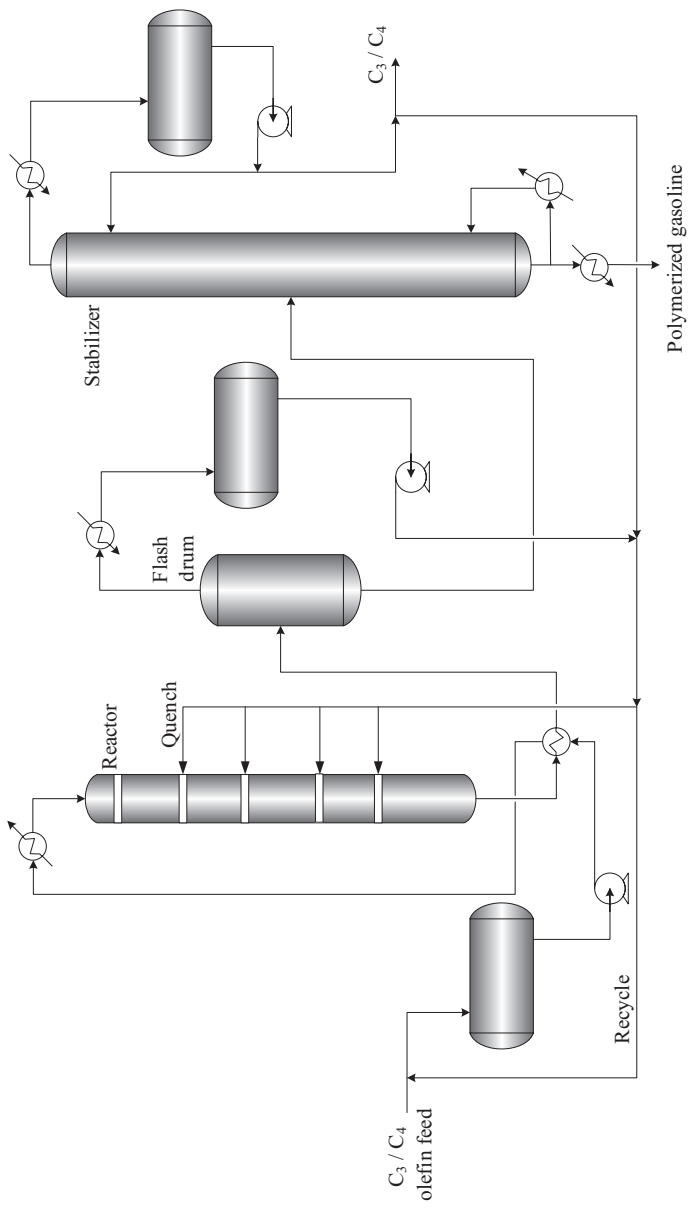

Figure 1.10. Typical process scheme of a polymerization unit.

- Adding a small amount of water to promote ionization of the acid before heating the olefin feedstream and passing over the catalyst bed
- Injecting a cold propane quench or by generating steam to control the reaction temperature since the polymerization reaction is highly exothermic
- Fractionating the product after leaving the reactor to separate the butane and lighter hydrocarbons from the polymer gasoline

1.4.5 Catalytic Hydrotreating

Catalytic hydrotreating (HDT) is one of the most important processes in the petroleum refining industry. The HDT process is applied to treat a great variety of refinery streams, such as straight-run distillates, vacuum gas oils [fluid catalytic cracking (FCC) feed], atmospheric and vacuum residua, light cycle oil, FCC naphtha, and lube oils. The main differences in the hydrotreating processes of each feed are the operating conditions, type of catalyst, reactor configuration, and reaction system. Depending on the feed and the main objective of the treatment, the process can be called *hydrodesulfurization* (HDS), as in the case of the HDS of straight-run naphtha, which is used as reforming feed where sulfur is the main undesirable heteroatom. For straight-run gas oil, the process is called *hydrotreating* because, in addition to sulfur removal, aromatic saturation and nitrogen removal are also desired for diesel fuel production. A hydrodemetallization process is used for the removal of vanadium and nickel from heavy oils. When a change in the molecular weight of the feed is required, a hydrocracking process is used.

Sulfur is removed primarily to reduce the sulfur dioxide (SO₂) emissions caused during fuel combustion. Removal of sulfur is also desired to have better feed for subsequent processes (e.g., catalytic reforming, fluid catalytic cracking). For naphtha HDS it is necessary to remove the total sulfur from the feed down to a few parts per million to prevent poisoning the noble metal catalysts in the catalytic reforming. For gas oil HDS, the production of ultralow-sulfur diesel (ULSD) requires the use of highly selective catalyst together with appropriate reaction conditions.

During hydrotreating a number of reactions are carried out: hydrogenolysis, by which C–S, C–N or C–C bonds are cleaved, and hydrogenation of unsaturated compounds. The reacting conditions of the HDT process vary with the type of feedstock; whereas light oils are easy to desulfurize, the desulfurization of heavy oils is much more difficult. The hydrotreating reactions take place in catalytic reactors at elevated temperatures and pressures, typically in the presence of a catalyst consisting of an alumina base impregnated with cobalt, nickel, and molybdenum. A typical hydrotreating unit involves the following steps (Figure 1.11):

- Mixing the liquid feed with a stream of hydrogen-rich recycle gas.
- Heating the resulting liquid–gas mixture to the desired reaction temperature.

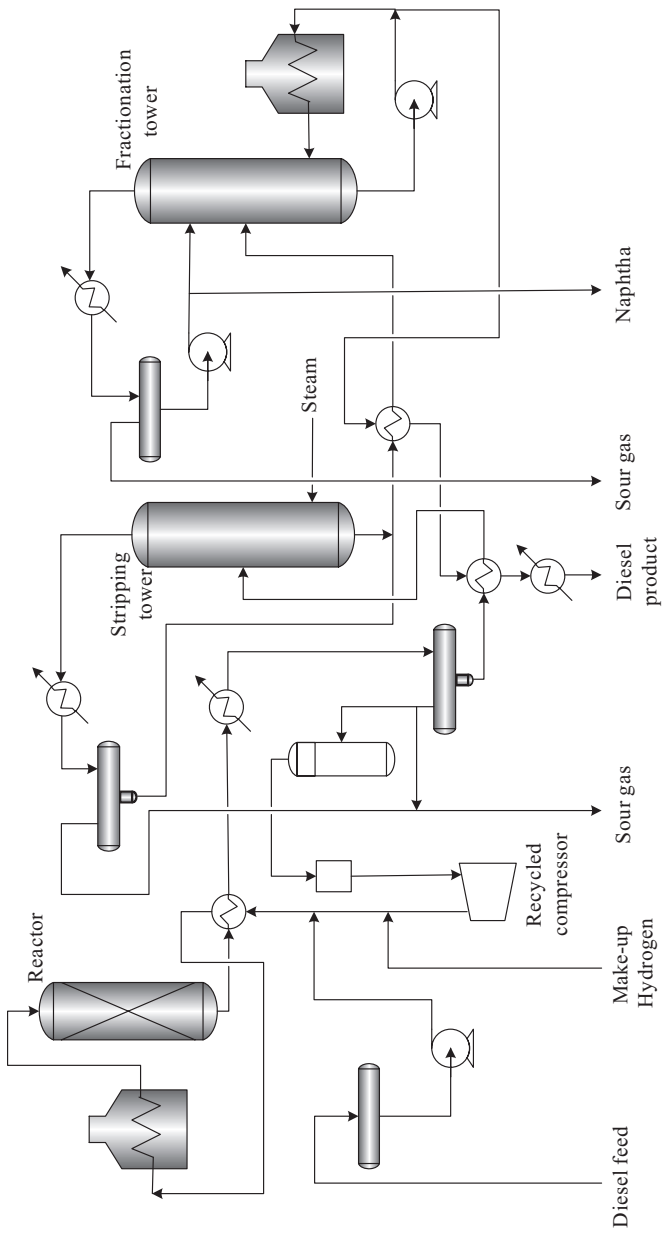

Figure 1.11. Typical process scheme of a hydrotreating unit.

- Feeding the mixture to the catalytic reactor, where the hydrotreating reactions take place.
- Cooling the reaction products and feeding them to a gas separator vessel.
- Sending most of the hydrogen-rich gas separated from this vessel through an amine contactor for removal of H_2S .
- Recycling the H_2S -free hydrogen-rich gas to the reactor.
- Sending the liquid from the gas separator vessel through a stripper distillation tower. The bottoms product from the stripper is the final desulfurized liquid product, while the overhead sour gas (i.e., hydrogen, methane, ethane, H_2S , propane, butane, and some heavier components) is sent to the amine gas treating. Subsequently, the H_2S removed and recovered is converted to elemental sulfur in a Claus process unit.

1.4.6 Fluid Catalytic Cracking

The *fluid catalytic cracking* (FCC) process is the heart of a modern refinery oriented toward maximum gasoline production. Within the entire refinery process, this process offers the greatest potential for increasing profitability; even a small improvement giving higher gasoline yields can result in a substantial economic gain. The FCC process increases the H/C ratio by carbon rejection in a continuous process and is used to convert the high-boiling, high-molecular-weight hydrocarbon fractions (typically, a blend of heavy straight-run gas oil, light vacuum gas oil, and heavy vacuum gas oil) to more valuable gasoline, olefinic gases, and other products.

The process consists of two main vessels: a reactor and a regenerator, which are interconnected to allow for transferring the spent catalyst from the reactor to the regenerator and the regenerated catalysts from the regenerator to the reactor. During catalytic cracking the feed is vaporized and the long-chain molecules are cracked into much shorter molecules by contacting the feed with a fluidized powdered catalyst at high temperature and moderate pressure.

Catalytic cracking reactions are believed to follow the carbonium ion mechanism, involving the following steps:

- *Initiation*: which starts from an early contact of an olefin with an active site of the catalyst at high temperature to produce the active complex corresponding to the formation of a carbocation
- *Propagation*: represented by the transfer of a hydride ion from a reactant molecule to an adsorbed carbenium ion
- *Termination*: corresponding to the desorption of the adsorbed carbenium ion to produce an olefin while the initial active site is restored

According to this mechanism, a catalyst promotes the removal of a negatively charged hydride ion from a paraffin compound or the addition of a positively charged proton (H^+) to an olefin compound, which results in the

formation of a carbonium ion. Carbonium ion is a positively charged molecule that has only a very short life as an intermediate compound and transfers the positive charge through the hydrocarbon. This carbonium transfer continues as hydrocarbon compounds come into contact with active sites on the surface of the catalyst that promote the continued addition of protons or the removal of hydride ions. The result is a weakening of carbon–carbon bonds in many of the hydrocarbon molecules and a consequent cracking into smaller compounds. These ions also react with other molecules, isomerize, and react with the catalyst to terminate a chain. Coke formation is unavoidable in the catalytic cracking process, which is probably formed by the dehydrogenation and condensation of polyaromatics and olefins. Fast deactivation by blocking the active pores of the catalyst is a consequence of coke deposition. During these reactions, the catalytic cracked gasoline produced contains large amounts of aromatics and branched compounds, which is beneficial for the gasoline's octane level.

A typical modern FCC unit consists of the following steps (Figure 1.12):

- Preheating the feed and mixing with the recycle slurry oil from the bottom of the distillation column.
- Injecting the combined feed into the catalyst riser, where vaporization occurs.

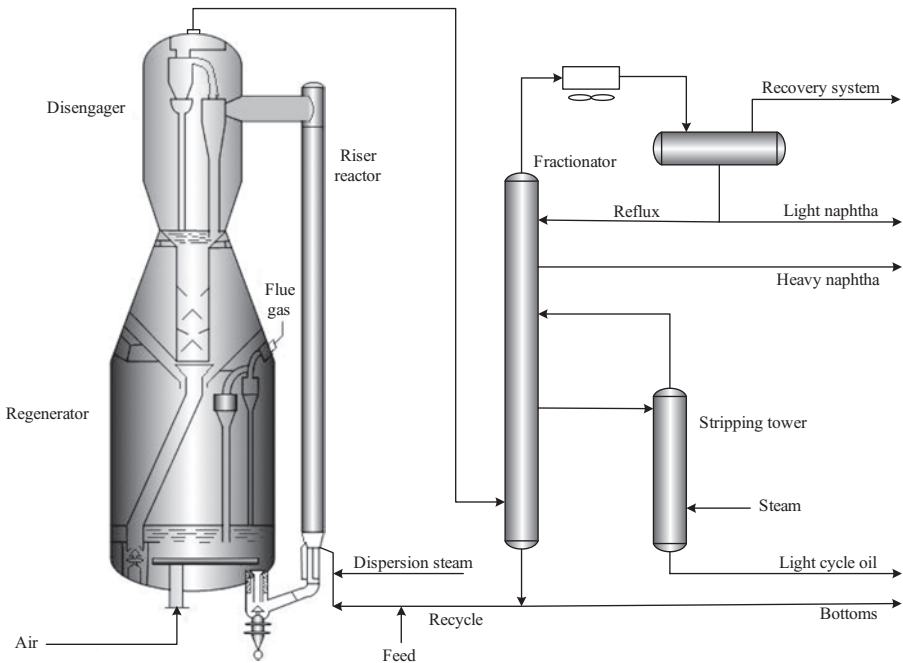

Figure 1.12. Typical process scheme of a fluid catalytic cracking unit.

- Cracking the vaporized feed into smaller molecules by contact with the hot powdered catalyst coming from the regenerator.
- Separation of the cracked product vapors from the spent catalyst by flowing through a set of two-stage cyclones.
- Stripping the spent catalyst with steam to remove any hydrocarbon vapors before the spent catalyst returns to the regenerator.
- Regeneration of the spent catalyst to burn off the deposited coke with blown air. This reaction is exothermic and produces a large amount of heat, which is partially absorbed by the regenerated catalyst and provides the heat required for feed vaporization and the endothermic cracking reactions that take place in the catalyst riser.
- Passing the hot flue gas leaving the regenerator through multiple sets of cyclones that remove entrained catalyst from the flue gas.
- Suitably separating the cracked product vapors from the reactor from entrained catalyst particles by cyclone and sending them to the recovery section of the FCC unit to meet the product stream requirements.

1.5 UPGRADING OF HEAVY FEEDS

Heavy feeds are characterized by low API gravity and high amounts of impurities. In general, it is known that the lower the API gravity, the higher the impurities content. Such properties make the processing of heavy feeds different from that used for light distillates, causing several problems:

- Permanent catalyst deactivation in catalytic cracking and hydrocracking processes, caused by metals deposition
- Temporary deactivation of acid catalysts, due to the presence of basic nitrogen
- Higher coke formation and lower liquid product yield, as a result of high Conradson carbon and asphaltene contents
- Products with high levels of sulfur

To reduce such problems, numerous catalytic and noncatalytic technologies are commercially available to upgrade heavy oils, which are summarized in the following sections.

1.5.1 Properties of Heavy Oils

Heavy oils exhibit a wide range of physical properties. Whereas properties such as viscosity, density, and boiling point may vary widely, the ultimate or elemental analysis varies over a narrow range for a large number of samples. The carbon content is relatively constant, while the hydrogen and heteroatom contents are responsible for the major differences in various heavy oils.

Heavy oils are comprised of heavy hydrocarbons and several metals, predominantly in the form of porphyrines. Heavy feeds also contain aggregates of resins and asphaltenes dissolved in the oil fraction, held together by weak physical interactions. With resins being less polar than asphaltenes but more polar than oil, equilibrium between the micelles and the surrounding oil leads to homogeneity and the stability of the colloidal system. If the amount of resin decreases, the asphaltenes coagulate, forming sediments. Asphaltenes are complex polar structures with polyaromatic character containing metals (mostly Ni and V) that cannot be defined properly according to their chemical properties, but they are usually defined according to their solubility. Thus, asphaltenes are the hydrocarbon compounds that precipitate by addition of light paraffin in the heavy oil. Asphaltenes precipitated with *n*-heptane have a lower H/C ratio than those precipitated with *n*-pentane, whereas asphaltenes obtained with *n*-heptane are more polar, have a greater molecular weight, and display higher N/C, O/C, and S/C ratios than those obtained with *n*-pentane.

Asphaltenes are constituted by condensed aromatic nuclei carrying alkyl groups, alicyclic systems, and heteroelements. Asphaltene molecules are grouped together in systems of up to five or six sheets, which are surrounded by the maltenes (all those structures different from asphaltenes that are soluble in *n*-heptane). The exact structure of asphaltenes is difficult to obtain, and several structures have been proposed for the asphaltenes present in various crudes. An asphaltene molecule may be 4 to 5 nm in diameter, which is too large to pass through micropores or even some mesopores in a catalyst. Metals in the asphaltene aggregates are believed to be present as organometallic compounds (porphyrine structure) associated with the asphaltene sheets, making the asphaltene molecule heavier than its original structure (Figure 1.13).

The complex nature of heavy oil fractions is the reason that refining of these feeds becomes so difficult. Therefore, an evaluation of the overall chemical and physical characteristics of petroleum feeds is mandatory to determine the processing strategy. Apart from having low API gravity (high density), high viscosity, and a high initial boiling point, heavy oils exhibit higher contents of sulfur, nitrogen, metals (Ni and V), and high-molecular-weight material (asphaltenes).

Generally, the majority of the sulfur and nitrogen species present in a crude oil is found in the heaviest fractions. These heteroatoms are removed from hydrocarbon streams in downstream refining units to produce ecologically acceptable fuels and/or to provide better quality feeds to subsequent processes: for example, feed with a low concentration of basic nitrogen is required to avoid the temporary poisoning effect on acid catalysts typically used in fluid catalytic cracking (FCC) and hydrocracking (HCR). Metals are found in most heavy oils in the form of metalloporphyrins and are concentrated exclusively in the residual fraction. The problem with metal-containing feeds is the permanent catalyst deactivation experienced in FCC, residue fluid catalytic cracking (RFCC), and HCR units. Asphaltenes are the most complex structures and

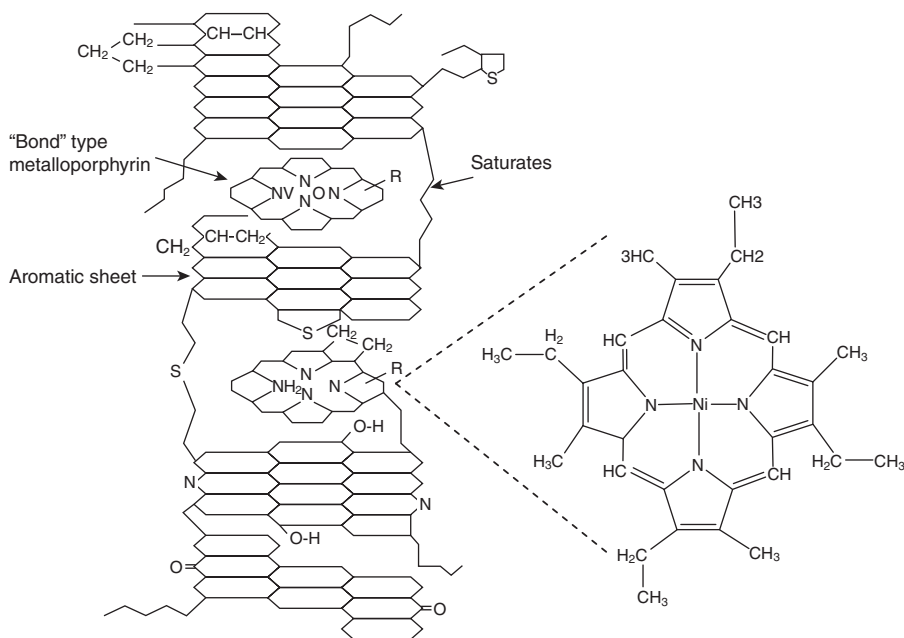

Figure 1.13. Hypothetical structure of an asphaltene molecule.

cause many problems in refining operations. Known as *coke precursors*, they reduce catalyst cycle life and liquid yield and are the main contributors of solids formation, producing fouling in all types of equipment.

The properties of petroleum residue vary widely, depending on the crude of origin, as shown in Table 1.8. Crude oils and their respective residua have a similar composition (e.g., sulfur, metals, and asphaltene contents), and the latter represents a significant portion of a barrel of crude oil. In the case of heavy petroleum, the yield of residue may be as high as 85%. For this reason, in the near future the material at the bottom of the barrel will be the main raw material for obtaining valuable liquid products, to keep up with fuel demand.

1.5.2 Process Options for Upgrading Heavy Feeds

General Classification One way to establish the quality of heavy oils is by the hydrogen-to-carbon (H/C) ratio. Values of about 1.5 indicate high-quality feed, while poor-quality oils may have an H/C ratio as low as 0.8. Therefore, to improve the quality of heavy oil, its H/C ratio needs to be increased either by increasing the hydrogen content or by decreasing the carbon content. Based on this consideration, processes for upgrading of heavy oils can be classified into two groups:

TABLE 1.8. Properties of Various Atmospheric Residua (AR), 343°C+

Crude Oil	Origin	API Gravity	Sulfur (wt%)	Ni + V (wppm)	Carbon Residue (wt%)	Yield of AR (vol%)
Ekofisk	North Sea	20.9	0.4	6	4.3	25.2
Arabian Light	Arabia	17.2	3.1	50	7.2	44.6
West Texas Sour	United States	15.5	3.4	29	9.0	41.6
Isthmus	Mexico	15.5	2.9	82	8.1	40.4
Export	Kuwait	15.0	4.1	75	—	45.9
North Slope	Alaska	14.9	1.8	71	9.2	51.5
Arabian Heavy	Arabia	13.0	4.3	125	12.8	53.8
Bachaquero	Venezuela	9.4	3.0	509	14.1	70.2
Maya	Mexico	7.9	4.7	620	15.3	56.4
Hondo	United States	7.5	5.8	489	12.0	67.2
Cold Lake	Canada	6.8	5.0	333	15.1	83.7
Athabasca	Canada	5.8	5.4	374	—	85.3
Ku-Maloob-Zaap	Mexico	3.7	5.8	640	20.4	73.7

1. *Hydrogen addition*: hydroprocesses such as hydrotreating and hydrocracking, hydrovisbreaking, and donor-solvent processes
2. *Carbon rejection*: coking, visbreaking, and other processes, such as solvent deasphalting

Both hydrogen addition and carbon rejection processes have disadvantages when applied to upgrading heavy oils. For example, removal of nitrogen, sulfur, and metals by exhaustive hydrodenitrogenation (HDN), hydrodesulfurization (HDS), and hydrodemetallization (HDM) is very expensive (excessive catalyst utilization), due to metal and carbon deposition. Noncatalytic processes yield uneconomically large amounts of coke and low liquid yield.

Processes for upgrading heavy oils are evaluated on the basis of liquid yield (i.e., naphtha, distillate, and gas oil), heteroatom removal efficiency (HDS, HDN, HDM), feedstock or residue conversion (RC), carbon mobilization (CM) and hydrogen utilization (HU), along with other process characteristics. Heteroatom removals and feedstock conversion are calculated from their corresponding amounts in feed and product:

$$\text{HDS, HDN, or HDM} = \frac{I_{\text{feed}} - I_{\text{product}}}{I_{\text{feed}}} \times 100 \quad (1.3)$$

$$\text{conversion (RC)} = \frac{538^{\circ}\text{C}_{\text{feed}}^{+} - 538^{\circ}\text{C}_{\text{product}}^{+}}{538^{\circ}\text{C}_{\text{feed}}^{+}} \times 100 \quad (1.4)$$

where I_{feed} and I_{product} represent the amount of impurity (sulfur, nitrogen, or metals) in the feed and product, respectively. $538^{\circ}\text{C}_{\text{feed}}^{+}$ and $538^{\circ}\text{C}_{\text{product}}^{+}$ are

the petroleum fractions in the feed and product, respectively, with a boiling point higher than 538°C (i.e., vacuum residue).

Carbon mobilization and hydrogen utilization are defined as follows:

$$CM = \frac{\text{carbon}_{\text{liquids}}}{\text{carbon}_{\text{feedstock}}} \times 100 \quad (1.5)$$

$$HU = \frac{\text{hydrogen}_{\text{liquids}}}{\text{hydrogen}_{\text{feedstock}}} \times 100 \quad (1.6)$$

High values of CM and HU correspond to high feedstock conversion processes such as hydrocracking (hydrogen addition). Since hydrogen is added, HU can be greater than 100%. On the contrary, low CM and HU correspond to low feedstock conversion, such as coking (carbon rejection).

The focus on the downstream and upstream petroleum sectors for each country may vary depending on the quality of crude oil. Significant advances have been made in these sectors over the last few decades. The downstream sector has traditionally been in charge of petroleum refining. However, with the increasing production of heavy petroleum, the upstream sector has entered into the upgrading area to increase the value of the oil produced. Thus, nowadays, both sectors are looking for better alternatives to upgrade and refine heavy petroleum.

Heavy oil upgrading is usually carried out directly by using the residue as feed after crude distillation. There is a wide range of catalytic and noncatalytic conversion processes that can be classified into the carbon rejection and hydrogen addition processes, as presented in Table 1.9. These processes use a variety of reactor designs and configurations, such as multi-fixed-bed systems, ebullated-bed reactors, fluidized reactors, and moving-bed reactors. Examples of some of these upgrading technologies are presented in Figure 1.14. The process technologies differ principally on the basis of the feedstock and process conditions (reactor) and catalyst used by the various licensors.

Carbon Rejection Processes The carbon rejection route is based on the removal of carbon in the form of coke with a low atomic hydrogen/carbon

TABLE 1.9. General Classification of Technologies for Upgrading of Heavy Petroleum Feeds

	Carbon Rejection	Hydrogen Addition
Noncatalytic	Solvent deasphalting Coking Visbreaking	Hydrovisbreaking
Catalytic	Catalytic cracking of residue	Hydrotreating Hydrocracking

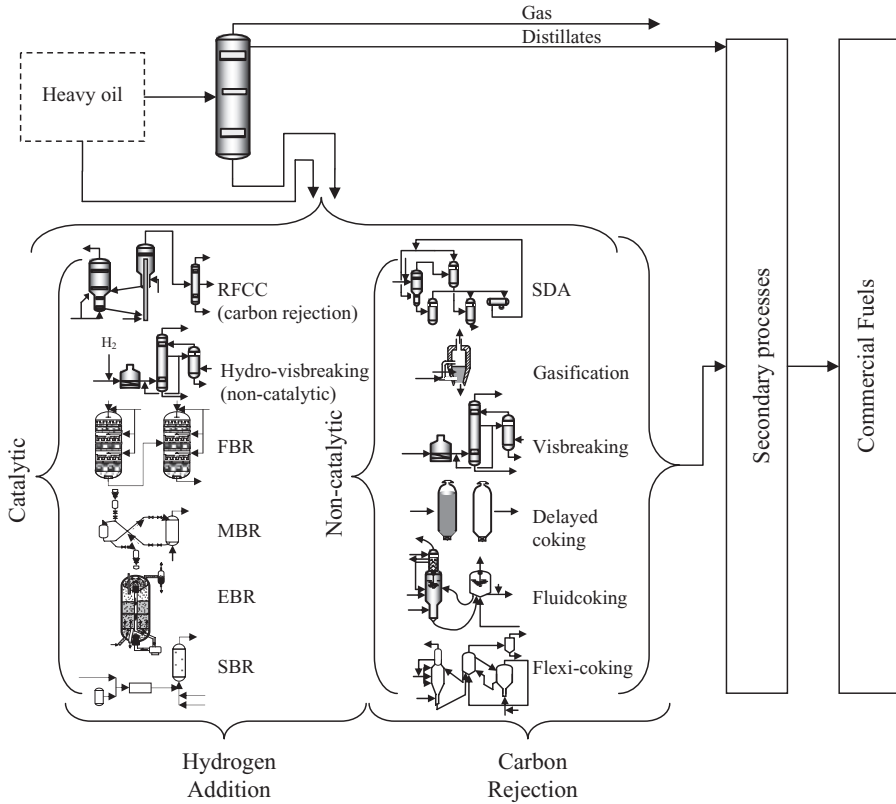

Figure 1.14. Process alternatives for upgrading of heavy oils.

ratio or in the form of asphalt (in the case of deasphalting), producing a moderate yield of liquid products. The following processes belong to this category: solvent deasphalting, thermal cracking processes such as coking and visbreaking, and catalytic cracking of residue.

Carbon rejection is an important process for residue conversion and is the most common method used commercially. In general, thermal cracking of residue is carried out at relatively moderate pressure and is often called the *coking process*. It is conducted at temperatures between 480 and 550°C and vapor-phase residence times of 20 or more, providing a significant degree of cracking and dehydrogenation of the feed, which makes subsequent processing more cumbersome and produces low-value by-products such as gas and coke. The coking process transfers hydrogen from the heavy molecules to the lighter molecules, resulting in the production of coke or carbon. The residue is hydrogen donors at high temperature.

The thermal conversion of heavy oil has attracted great interest in recent years, due to the decrease in middle distillate or increase in low-quality crude oil. Thermal processes produce a relatively high amount of gas, such as methane,

ethene, propene, butane, and secondary products such as LPG and dry gas. Coke is a significant by-product whose formation mechanism is different from that of other products. Some of the thermal processes are coupled with catalytic processes. The catalytic pyrolysis of heavy oil may be a good option for a petrochemical refinery but not for the transportation of fuel oil.

Solvent deasphalting (SDA), described earlier, is a separation process in which the asphaltenic fraction is precipitated from the residue using a light paraffinic solvent (i.e., propane, butane, pentane, or *n*-heptane). The product is a low-sulfur/metal deasphalted oil (DAO) rich in paraffins that is normally used as feed for FCC and hydrocracking. The advantages of this method are the relatively low cost, the flexibility to adjust the DAO quality in a wide range, and the elimination of fouling problems in subsequent units. However, disposal of the SDA pitch (asphaltenic fraction) is still a matter of concern.

Thermal cracking processes are the most mature technologies for converting heavy feeds. They are carried out at moderate pressure in the absence of a catalyst. Coking processes (i.e., delayed coking, fluid coking, and flexicoking) are capable of eliminating the heaviest fractions from crude oils, producing coke that contains the majority of sulfur, nitrogen, and metals of the original oil. Delayed coking has been the upgrading process of choice, due to its flexibility to handle any type of feed and its ability to remove carbon and metals completely, along with partial conversion to liquids. Fluid coking and flexicoking are advanced processes that employ fluidized-bed technology, derived from FCC technology. Technically, fluid coking is only marginally better than delayed coking, as it offers a slightly higher liquid yield, less coke formation, and lower operating costs. *Visbreaking*, on the other hand, is a mild thermal decomposition process to improve the viscosity of heavy oils and residue, without significant conversion to distillates. In general, thermal processes appear to be attractive, due to low investment and operating costs; however, they suffer from the disadvantage of producing uneconomically large amounts of coke and having a low liquid yield. Additionally, liquid products require extensive posttreatment to meet the specifications of commercial fuels.

Catalytic cracking of residue (RFCC) is the only catalytic process found in this class of upgrading technologies. It is an extension of conventional FCC, which is employed for converting heavy feedstocks into high-octane gasoline blending components. RFCC exhibits better selectivity to gasoline and a lower gas yield than thermal cracking and hydroprocessing. However, the main drawback of RFCC is the need for good-quality feed (low metals content and H/C ratio) to avoid high coke production and excessive catalyst use; therefore, the application of RFCC directly to residues derived from heavy oil is not likely.

Additional details regarding these processes are given in the following sections.

Solvent Deasphalting Since asphaltenes cause many problems during various steps of petroleum refining, it is more convenient to remove them from heavy

oil and make it a trouble-free feedstock. For example, if asphaltene separation is carried out before hydroprocessing, the following main problems encountered when handling heavy feeds can be avoided:

- Pipeline deposition and its plugging
- Efficiency decrease in refinery plants
- Precipitation of asphaltene due to blending of light hydrocarbon streams
- Sludge and sediment formation during storage as well as processing
- Catalyst deactivation in downstream processes

The most common method used for asphaltene precipitation is *solvent deasphalting* (SDA). This process uses a solvent (light paraffin such as C₃, C₄, C₅, C₆, and C₇) to separate a residue into a deasphalted oil (DAO) and a pitch (asphaltene), the latter containing most of the impurities of the feedstock. The insoluble pitch will precipitate out of the mixed feedstock as asphaltene. Separation of the DAO phase and the pitch phase occurs in an extractor. The extractor is designed to separate the two phases efficiently and to minimize contaminant entrainment in the DAO phase. At a constant solvent composition and pressure, a lower extractor temperature increases the DAO yield and decreases the quality. With an increase in solvent ratio the DAO yield remains constant, improves the degree of separation of individual components, and results in the recovery of a better quality DAO. The solvent recovered under low pressure from the pitch and DAO strippers is condensed and combined with the solvent recovered under high pressure from the DAO separator, which is then recycled to the initial stage. DAO is normally used as fluid catalytic cracking or hydrocracker feed.

Solvent deasphalting is used in refineries to upgrade heavy bottoms streams to deasphalted oil that may be processed to produce transportation fuels. The process may also be used in the oil field to enhance the value of heavy crude oil before it gets to the refinery. Thus, SDA is an economically attractive and environmentally friendly process to upgrade heavy petroleum.

Gasification Gasification involves complete cracking of residue, including asphaltenes, into gaseous products. The gasification of residue is carried out at a high temperature (>1000°C) having synthesis gas (consisting primarily of hydrogen, carbon monoxide, carbon dioxide, and water), carbon black, and ash as major products. The syngas can be converted to hydrogen or used by cogeneration facilities to provide low-cost power and steam to refineries. An integrated SDA-gasification facility is an attractive alternative for upgrading of heavy petroleum. The following are some of the benefits obtained in integrating deasphalting and gasification:

- Heavy oils can be upgraded economically.
- Capital and operating costs of both processes can be reduced.

- Higher yields of DAO are possible.
- Lower emissions are possible.
- Profit margins of a refinery can be increased.

Coking Depending on feedstock properties, coker unit design, and operating conditions, the solid product (petroleum coke or “petcoke”) can be:

- *Fuel-grade coke*: the most common type of coker is the fuel grade, whose main objective is to maximize liquid yields and reduce low-value coke formation. This coke is used as fuel in process heaters and power generation facilities.
- *Anode-grade coke*: which is produced from low-sulfur and metals feeds, and is used for anodes in the aluminum industry.
- *Needle-grade coke*: which is produced from highly aromatic feedstocks with low asphaltenes, sulfur, and ash contents. This coke, with high strength and a low coefficient of thermal expansion, is used to manufacture large electrodes for the steel industry and the production of synthetic graphite.

The physical and chemical properties of fuel coke, anode coke, and needle coke vary substantially.

Three main coking processes are in use:

1. *Delayed or retarded coking*: which can produce shot coke (a type of fuel coke), sponge coke (used to produce anode coke or as a fuel coke), or needle coke. This process accounts for the majority of the coke produced in the world today.
2. *Fluid coking*: which produces fluid coke typically used as fuel coke.
3. *Flexicoking*: which produces a type of fluid coke that is gasified to generate a low-Btu synthesis gas.

1. **DELAYED COKING** *Delayed coking* is a semicontinuous thermal cracking process used in petroleum refineries to upgrade and convert bottoms from atmospheric and vacuum distillation of crude oil into liquid and gas product streams, leaving behind a solid concentrated carbon material, petroleum coke, whose value will depend on its properties, such as sulfur or metals. The products of a delayed coker are wet gas, naphtha, light and heavy gas oils, and coke. The coke produced in the delayed coker is almost pure carbon and is utilized as fuel or, depending on its quality, in the manufacture of anodes and electrodes.

In a delayed coker the feed enters the bottom of the fractionator, where it mixes with recycle liquid condensed from the coke drum effluent. It is then pumped through the coking heater, then to one of two coke drums through a switch valve. The total number of coke drums required for a particular application depends on the quality and quantity of the feed and the coking cycle

desired. A minimum of two drums is required for operation, with one drum receiving the heater effluent while the other is being decoked.

A delayed coking unit is frequently designed with the objective of maximizing the yield of liquid product and minimizing the yields of wet gas and coke. The conversion is accomplished by heating the feed material to a high temperature and introducing it into a large drum to provide soaking or residence time for the three major reactions to take place:

- Partial vaporization and mild cracking (visbreaking) of the feed as it passes through the coker's furnace.
- Thermal cracking, the mechanism through which high-molecular-weight molecules are decomposed into smaller, lighter molecules that are fractionated into the products. The reaction is highly endothermic. The coker heaters supply the heat necessary to initiate the cracking reaction. Heater temperature and residence time are strictly controlled, so that coking in the heaters is minimized.
- Polymerization, the reaction through which small hydrocarbon molecules are combined to form a single large molecule of high molecular weight. The result of this reaction is the formation of coke. Polymerization reactions require a long reaction time and the coke drums provide the necessary residence time for these reactions to proceed to completion.

Delayed coking has been selected by many refiners as their preferred choice for upgrading the bottom of the barrel, because of the process's inherent flexibility to handle any type of residua. The process provides essentially complete rejection of metals and carbon while providing partial conversion to liquid products (naphtha and diesel). The product selectivity of the process is based on the operating conditions, mainly pressure and temperature. This process is more expensive than SDA, although still less expensive than other thermal processes. The disadvantages of this process are the very high coke formation and low yield of liquid products. Despite these disadvantages, delayed coking is the favorite process of all refiners for residue processing. Advances in delayed coking have increased light products while decreasing coke production, lowering pressure and oil recirculation.

2. FLUID COKING AND FLEXICOKING *Fluid coking* is a continuous process that uses the fluidized-solids technique to convert residue feedstock to more valuable products. The heated coker feeds (petroleum residua) are sprayed into a fluidized bed of hot, fine coke particles which are maintained at 20 to 40psi and 500°C. The use of a fluid bed permits the coking reactions to be conducted at higher temperatures and with shorter contact times than in delayed coking. These conditions result in lower yields of coke and higher yields of liquid products. Fluid coking uses two vessels, a reactor and a burner. Coke particles are circulated between them to transfer heat to the reactor.

This heat is generated by burning a portion of the coke. The reactor contains a fluidized bed of the coke particles, which is agitated by the introduction of steam below. The residue feed is injected directly into the reactor and is distributed uniformly over the surface of the coke particles, where it cracks and vaporizes. The feed vapors are cracked while forming a liquid film on the coke particles. The particles grow by layers until they are removed and new seed coke particles are added. Coke is a product and a heat carrier. *Flexicoking* is an extension of fluid coking which includes the gasification of the coke produced in the fluid coking operation and produces syngas, but the temperature (1000°C) used is insufficient to burn all coke.

Both fluid coking and flexicoking are fluid-bed processes developed from fluid catalytic cracking technology. In both processes, the circulating coke carries heat from the burner back to the reactor, where the coke serves as reaction sites for the cracking of the residua into lighter products. Fluid coking can have liquid yield credits over delayed coking. The shorter residence time can yield higher quantities of liquids and less coke, but the products are lower in quality. Fluid coking is a slightly better process than delayed coking because of the advantage of a slightly improved liquid yield, and because delayed coking has a higher utilities cost and higher fuel consumption.

Visbreaking *Visbreaking* (viscosity reduction or breaking), a mature process that may be applied to both atmospheric residua (AR) and vacuum residua (VR) and even solvent deasphalted pitch, improves viscosity by means of its mild thermal decomposition. The thermal conversion of the residue is accomplished by heating at high temperatures in a specially designed furnace. A common operation is to visbreak residue in combination with a thermal cracker to minimize fuel oil while producing additional light distillates.

Visbreaking is a process in which a residue stream is heated in a furnace (450 to 500°C) and then cracked during a low specific residence time, to avoid coking reactions within a soaking zone under certain pressure and moderate temperature conditions. The cracked product leaves the soaking zone after the desired conversion is reached, and is then quenched with gas oil to stop the reaction and prevent coking, although increased conversion during visbreaking will turn to more sediment deposition. The residence time, temperature, and pressure of the furnace's soaking zone are controlled to optimize the thermal free-radical cracking to produce the desired products. In general, visbreaking is used to increase refinery net distillate yield. The main objectives of visbreaking are to reduce the viscosity of the feed stream and the amount of residual fuel oil produced by a refinery and to increase the proportion of middle distillates in the refinery output.

Carbon rejection processes are characterized by having lower investment and operating costs than those of hydroprocessing, but the yield of light products tends to be lower, which is not favored by refiners. Moreover, liquid products obtained from thermal processes contain S, N, and metals (e.g., V, Ni) that need

further purification by hydrotreating processes such as HDS, HDN, and HDM, respectively. Thus, thermal processes and coking-based technologies suffer from the disadvantages of producing a large amount of low-value by-products and require further extensive processing of the liquid products. Therefore, the importance of thermal processes remains lower than that of catalytic processes, but due to their lower investment, these processes remain most common for residue upgrading.

Some of the advantages and disadvantages of carbon rejection processes are as follows:

- Visbreaking is the least expensive process but provides only a modest degree of residue conversion. Its applicability is constrained further by oil-quality considerations involving stability and compatibility.
- Delayed coking is relatively easy to implement, requires a moderate investment, provides a high degree of conversion, but may produce a large amount of low-value coke.
- Fluid coking is similar to delayed coking in many aspects but produces higher yields. However, the coke produced usually has a lower value, and the gas oils are somewhat more difficult to refine.

Residue Fluid Catalytic Cracking Fluid catalytic cracking is a well-established process for converting a significant portion of the heavy fractions (typically, heavy straight-run gas oil and light and heavy vacuum gas oils) of the crude barrel into a high-octane gasoline blending component. Residue fluid catalytic cracking (RFCC) is an extension of conventional FCC technology developed during the early 1980s which offers better selectivity to high gasoline and lower gas yield than that of hydroprocessing and thermal processes. The RFCC process uses reactor technology similar to that of the FCC process, in which the catalyst is in a fluidized bed at 480 to 540°C and is targeted for residual feeds greater than 4wt% Conradson carbon. Because RFCC requires better feed quality (e.g., a high H/C ratio, a low metal and asphaltene content), it makes this process less likely than hydroprocessing. The need for good feedstock quality is to avoid unreasonable high coke yield, high catalyst consumption, and unit operability. However, such feeds are high in price and limited in refineries.

To control heat balance and to recover part of the heat for steam production, RFCC process design includes two-stage regeneration: mix temperature control and catalyst cooler. The catalyst properties also play an important role in resisting metal content and carbon deposition. In this respect catalyst pore structure limits the diffusion of residue on the catalytic sites. The catalyst used for RFCC is an acidic matrix such as crystalline aluminosilicate zeolite in an inorganic matrix, which fulfills the required physical–chemical properties.

Hydrogen Addition Processes The hydrogen addition route, better known as *hydroprocessing*, reduces coke formation in favor of liquid products by means of a hydrocracking or hydrogenolysis mechanism. Hydroprocessing is

a hydrogen addition process which increases the H/C ratio in products. It is the most attractive route for upgrading heavy crudes and residua. In general, hydroprocessing requires hydrogen to hydrogenate the oil at high pressures and temperatures in the liquid phase because such oils have a very high concentration of carbon. Asphaltene conversion is more complicated for heavy oils, since a wide range of molecular changes occur with temperature. Except for hydrovisbreaking, a mild process based on visbreaking but in a hydrogen atmosphere, hydroprocessing is carried out in the presence of a catalyst. Catalytic hydroprocessing is extremely relevant in petroleum refining for upgrading a variety of streams; ranging from straight-run naphtha to vacuum residues or even heavy and extra-heavy crude oils. When handling heavy feeds, hydroprocessing has the virtue of reducing the contents sulfur, nitrogen, metals (Ni and V), and asphaltenes, and contributing simultaneously to the production of liquid fuels by HCR. Nevertheless, processing of this type of feed presents many difficulties caused principally by enhanced metal and carbon deposition on the catalyst.

There are numerous hydroprocessing technologies for converting heavy feeds, differing mainly in catalyst type, reactor technology, and operating conditions. The catalyst system is chosen based on activity, selectivity, and cycle life and is generally composed of CoMo/NiMo alumina-supported catalysts designed for specific objectives, such as hydrodesulfurization (HDS), hydrodemetallization (HDM), hydrodenitrogenation (HDN), hydrodeasphaltenization (HDA), HCR, and Conradson carbon (CCR) removal. Commercial reactor technologies for hydroprocessing of heavy feeds can be classified according to the type of catalytic bed: fixed, moving, ebullated, and slurry. Selection of the reactor is generally a function of the quality and composition of the feedstock and desired level of conversion and impurities removal. Typically, dirty feeds can be processed effectively in ebullated-bed reactors, since the major disadvantage of fixed-bed reactors is the catalyst deactivation with time onstream. The major selection criterion between each type of reactor is based on the catalyst deactivation rate, which depends on the contents of metals and asphaltenes in the feed, as the products formed during their removal are known as *catalyst deactivating species*. Reaction severity [i.e., pressure, reaction temperature, hydrogen-to-oil ratio, and liquid hourly space velocity (LHSV)] also depends on the properties of the feed and the product quality desired; in general, for higher-boiling-point feeds, more severe conditions are required.

Traditionally, fixed-bed reactors were employed for processing light feeds, but they were gradually adapted for tougher feeds, such as vacuum gas oil and residua. The main disadvantage of using fixed-bed reactors for upgrading heavy feeds is the loss of catalyst activity during time-on-stream. This reduces the length of run drastically, due to the frequent shutdowns required for replacing the catalyst. However, recent advances in the field have led to the development of layered catalyst systems that extend significantly the length of run. Typically, these systems comprise a front-end HDM catalyst, a midsection catalyst with balanced HDM/HDS activity, and a tail-end highly

active HDS/HCR catalyst. The front-end catalyst exhibits a high-metal-uptake capacity, and its main function is to disaggregate asphaltene molecules for metals removal, so that the downstream catalysts can operate with hydrocarbons of low metal and coke precursor content. In the midsection, there is additional metals elimination and partial HDS, whereas the tail-end catalyst provides hydroconversion. The combination of catalysts is selected according to the objectives of each situation.

Among all the possibilities available for treatment of heavy oils, hydrogen addition processes lead to high hydrogen consumption but higher liquid yields. These processes, which provide the feedstock for subsequent processes, require the use of well-designed catalysts capable of dealing with the high concentration of metals and asphaltenes present in the feedstock. Moreover, the multifunctional catalysts used for hydrocracking processes become poisoned by coke deposition and the heavy metals present in the feed, creating a hazardous waste which has to be disposed off properly and with safety. A high catalyst demetallization function is necessary because vanadium destroys the zeolitic catalyst used in the subsequent FCC process. Moreover, the concentration of nitrogen compounds must be reduced to a minimum to avoid poisoning the catalyst acid sites in this and subsequent FCC process. Although in the hydrocracking process the amount of metals is not as critical as in FCC, the elimination of nitrogen compounds is determinant to avoid poisoning of the catalyst acid sites.

Catalyst cycle life does not represent a problem in moving- and ebullated-bed reactors. Such technologies allow for replacing spent catalyst without interrupting operation; therefore, they are adequate for handling the most problematic feeds (high contents of metals and asphaltenes). Moving-bed reactors combine fixed-bed operation in plug-flow mode with the possibility of replacement during time-on-stream portions of spent catalyst. Catalyst replacement is a batch operation, typically carried out once or twice a week. The application of these reactors is specifically in front-end residue demetallization to protect subsequent fixed-bed reactors for HDS and HCR. Ebullated-bed reactors represent the most advanced hydroprocessing technology, suited specifically for upgrading extra-heavy feeds, directly without any type of pretreatment. The continuous catalyst replacement feature in these reactors allows using conventional high-activity HDT/HCR catalysts. Operation of these reactors is very flexible, hydroconversion is very efficient (up to 90 vol%), and products have low levels of sulfur, metals, and nitrogen. Nevertheless, ebullated-bed technologies suffer from considerable sediment formation and high catalyst consumption. Also, scale-up and design of such reactors is more difficult, due to the complex hydrodynamics.

Residue desulfurization processes (RDS/VRDS) are of common use to meet a variety of objectives, such as preparing feed for FCC, RFCC, coker, and HCR, and are available from major licensors (Chevron, Unocal, UOP, Shell, and Exxon). IFP's Hyvahl-F is another process of this nature, characterized by a system of fixed-bed reactors in series in combination with a graded

catalyst system employed for atmospheric and vacuum residue hydrotreating and conversion to liquid fuels. Aiming to increase run length, this process was modified by introducing a swing reactor system (SRS) in front of the conventional fixed-bed reactor train. The SRS, under the brand name Hyvahl-S, has two reactors that can alternate in operation when the catalyst in one reactor is deactivated. Other advances in this field include systems for shortening the time required to replace spent catalyst, such as Shell's quick catalyst replacement system (QCR), which avoids opening and closing the reactor to load and unload catalyst. Examples of commercial developments using the moving-bed approach are the Hycon process developed by Shell and Chevron's onstream catalyst replacement reactor (OCR).

Ebullated-bed reactors are employed for residue hydrocracking as well as for desulfurization and demetallization. The two major commercialized technologies that use this type of reactor are H-Oil, licensed by Axens (IFP), and LC-Fining, licensed by Chevron Lummus. The two have very similar characteristics in terms of process parameters and reactor design, but differ in some mechanical details.

In summary, all of these processes have serious drawbacks when applied individually to the conversion of heavy feeds; thermal processes alone yield large amounts of coke, while catalytic processes suffer from excessive catalyst consumption due to rapid deactivation and high-hydrogen inputs in the case of hydroprocessing. Therefore, a careful inspection of feed characteristics, desired goals, and available technologies is required to define the best refining strategy. Either way, hydroprocessing will play an essential role in this matter, as it is favorable for primary upgrading and certainly offers much better selectivity to liquid yield and substantially cleaner products than thermal processes. Optimal hydroprocessing can be achieved by proper matching of reactor technology, catalyst, and reaction severity with the properties of heavy feeds.

Hydrovisbreaking Processing

1. HYCAR This is one type of noncatalytic process, based on visbreaking and involving treatment with hydrogen at mild conditions. This process is completed in three reactors:

- **Visbreaking.** This reactor carries out a moderate thermal cracking process in the presence of hydrogen. Hydrogen leads to more stable products than those obtained with straight visbreaking, which means that higher conversions can be achieved, producing a lower-viscosity product while no coke formation is induced.
- **Hydrodemetallization.** This reactor is to remove contaminants, particularly metals, prior to HCR. The product coming from the visbreaker is fed to the demetallization reactor in the presence of catalyst, which provides pore of sufficient size for diffusion and adsorption of high-molecular-weight constituents.

- **Hydrocracking.** In this reactor desulfurization and denitrogenation take place along with hydrocracking. Hydrocracking and hydrodemetallization reactors may employ inexpensive catalyst (CoMo) to remove metals and for cracking of complex molecules, respectively.

2. **AQUACONVERSION** Another type of hydrovisbreaking technology is aquaconversion, which is a catalytic process that uses catalyst-activated transfer of hydrogen from water added to the feedstock in slurry mode. The homogeneous catalyst is added in the presence of steam, which allows the hydrogen from the water to be transferred to the heavy oil when contacted in a coil-soaker system, normally used for the visbreaking process. Reactions that lead to coke formation are suppressed and there is no separation of asphaltene-type material.

The main characteristics of aquaconversion are:

- Hydrogen incorporation is much lower than that obtained when using a deep hydroconversion process under high hydrogen partial pressure.
- Hydrogen saturates the free radicals, formed within the thermal process, which would normally lead to coke formation.
- A higher conversion level can be reached, and thus higher API and viscosity improvements, while maintaining syncrude stability.
- It does not produce coke.
- It does not require a hydrogen source or high-pressure equipment.
- It can be implanted in the production area, thus eliminating the need for external diluent and its transport over large distances. Light distillates from the raw crude can be used as a diluent for both the production and desalting processes.

The presence of an oil-soluble catalyst and water prevents the coke formation and deposition of sediment that often occurs during visbreaking. In this process catalyst may be used as a support or mixed directly with the feedstock. The metals (metal salts) used for hydrovisbreaking are alkali metals such as potassium or sodium. The role of the catalyst is to enhance the dissociation of H_2O to release hydrogen (H^+) ions, which is subsequently consumed in hydroprocessing.

Fixed-Bed Hydroprocessing Hydroprocessing of residue in a fixed-bed reactor is well established and reported in the literature. The general characteristic of hydroprocessing is the simultaneous or sequential hydrogenation of hydrocarbon feed in the presence of sulfided catalyst by reacting with hydrogen. The main problem with fixed-bed catalyst is deactivation over time, which can be minimized by a guard-bed reactor in order to reduce metal deposition on the downstream reactors. Several combinations using two or three processing steps can be implemented in the refining. The catalyst in the guard-bed

reactor is typically an HDM catalyst or large-pore catalyst with a high metal retention capacity.

Various improvements have been reported in the last decade to increase the efficiency of fixed-bed hydroprocessing, such as run length, conversion, and product quality. Some of these improvements have been focused on mechanical design, such as the use of a bunker, swing reactors, guard-bed reactors, feed distribution, and a coke and metal deactivation-resistant catalyst, including pore and particle grading and onstream catalyst replacement. Despite all disadvantages, mainly short catalyst life, up until now most residue hydroprocessing units have used fixed-bed reactors.

1. **RDS/VRDS** The RDS process is used for atmospheric residuum hydrotreating and the VRDS process for vacuum residuum desulfurization to remove sulfur and metallic constituents while part of the feedstock is converted to lower-boiling products. In both processes, AR or VR feedstocks contact with catalyst and hydrogen at moderate temperatures and pressures, consuming about 700 to 1300 standard cubic feet (SCF) H_2 /bbl of feed. The conversion increases with temperature, but due to the high coke deposition, the process is not appropriate for use at high temperature. The RDS and VRDS processes do not convert directly to transportation fuel, but this process is able to produce acceptable feedstock for RFCC or delayed coking units to achieve minimal production of residual products in a refinery. The basic process flow and catalyst are the same for RDS and VRDS.

A combination of RDS/VRDS and RFCC has gained wide acceptance due to the selective conversion of residue and smaller amount of by-products. The limitation for RFCC is deposited metals, since Ni deposition increases olefin yields through dehydrogenation, and as a result more coke formation is obtained, while deposition of V metal destroys the zeolite structure. Also, the combination of a desulfurization step and VRDS is often seen as an attractive alternative to the atmospheric residuum desulfurizer. In addition, either RDS or VRDS can be coupled with other processes (such as delayed coking and solvent deasphalting) to achieve the optimum refining performance.

2. **HYVAHL-F AND HYVAHL-S** These processes are used to hydrotreat AR and VR feedstocks to convert them into more valuable products (naphtha and middle distillates). Hyvahl processes are designed primarily for feedstock containing high concentrations of asphaltene, maltenes, and metals, which strongly limit catalyst performance. The reactors can be used in the classical fixed-bed (Hyvahl F) or swing-mode system (Hyvahl S). Hyvahl-F uses fixed-bed reactors in which liquid and gas flow downstream co-currently in a trickle-flow regime. The first catalyst is resistant to fouling, coking, and plugging by asphaltene constituents, has a high metals retention capacity, and is used for both hydrodemetallization and most of the conversion. So the highly active second catalyst is protected from metal poisons and deposition of cokelike products and can carry out its deep hydrodesulfurization and refining functions. Its main

application is for processing distillate fractions and some atmospheric residua. For vacuum residua and heavy oils, it may require frequent catalyst replacements, which may be complex and uneconomical. Optimization of catalyst properties, space velocity, and maximum reaction temperature may extend the life of the catalyst, depending mainly on the metals content in the feed. Hyvahl-S, also called the Hyvahl-F-swing reactor, uses two guard reactors in a swing arrangement and switchable operation, which are fixed-bed reactors with simple internals. This configuration allows fast switching of the guard reactor in operation with a deactivated catalyst to the other guard reactor with fresh catalyst, without shutting down the plant. The major feature of this process is a fixed bed using the swing-mode reactor concept at high temperature, high hydrogen pressure, and low contact time. The switching of guard reactor and adjusting of conditions are fast and controlled by a conditioning package.

3. RESIDUE HYDROCRACKING The growing demand for middle distillates has increased the need for HCR in terms of process flexibility as well as configuration and product composition. The catalysts used for HCR should have dual functionality [i.e., cracking and hydrogenation (HYD) functions]. The process scheme of a typical HCR fixed-bed system contains two reactors. The first reactor (first-stage HCR) contains an HDT catalyst of high activity for the removal of heteroatoms or metal, while the second reactor (second-stage HCR) contains the actual HCR catalyst. In general, the first-stage reactor contains NiMo catalyst, which removes S, N, metals, and hydrogenate aromatics, while the second reactor possesses an acidic support (zeolite, mixed oxides)-based catalyst that promotes hydrogenation as well as hydrocracking reaction.

In contrast to HDT, the support plays an active role in the conversion of the feed in HCR catalyst. The performance of HCR catalyst is determined by the ratio or balance between the hydrogenation metal (sulfide) site and the acid sites of support. When the number of hydrogenating sites is low compared with the number of acid sites, secondary cracking processes can take place, resulting in light products. Additionally, the hydrogenation function also prevents the oligomerization and coking over the acid sites. A deficient hydrogenation function will lead to enhanced deactivation of the catalyst. On the other hand, when a very strong hydrogenation function is used, cracking is suppressed in favor of isomerization. In the ideal HCR the catalyst requires a balance between metal and acid functions.

Several fixed-bed hydrocracking processes are used by refiners on the basis of their product selectivity:

- *IFP hydrocracking.* This process features a dual-catalyst system. The first catalyst is a promoted NiMo amorphous catalyst which acts to remove sulfur and nitrogen and hydrogenate aromatic rings, while the second catalyst is a zeolite which finishes the hydrogenation and promotes the hydrocracking reaction. There are two versions of this process:

- Single-stage process. The first reactor effluent is sent directly to the second reactor, followed by separation and fractionation steps. The fractionator bottoms are recycled to the second reactor or sold.
- Two-stage process. The feedstock and hydrogen are heated and sent to the first reaction stage, where conversion to products occurs. The reactor effluent phases are cooled and separated and the hydrogen-rich gas is compressed and recycled. The liquid leaving the separator is fractionated, the middle distillates and lower-boiling streams are sent to storage, and the high-boiling stream is transferred to the second reactor section and then recycled to the separator section.
- *Isocracking*. Depending on the feedstock properties, there are various process flow schemes: single-stage once-through liquid; single-stage partial recycle of heavy oil; single-stage extinction recycle of oil (100% conversion); and two-stage extinction recycle of oil. The isocracking process uses multibed reactors and a number of catalysts. The catalysts are dual function, being a mixture of hydrous oxides (for cracking) and heavy metal sulfides (for hydrogenation). The catalysts are used in a layered system to optimize the processing of the feedstock, which undergoes changes in its properties along the reaction pathway.
- *Mild hydrocracking*. This process uses operating conditions (and a flow scheme) similar to those of a vacuum gas oil desulfurizer to convert the feed into significant yields of lighter products. The conditions for mild hydrocracking are typical of many low-pressure desulfurization units, and the process is a simple form of hydrocracking.
- *MRH*. MRH is a hydrocracking process designed to upgrade heavy feedstocks containing large amounts of metals and asphaltene, such as VR and bitumen, and to produce mainly middle distillates. The reactor is designed to maintain a mixed three-phase slurry of feedstock, fine powder catalyst, and hydrogen, and to promote effective contact.
- *Unicracking*. There are various versions of this process:
 - *Basic unicracking*. This is a fixed-bed catalytic process designed as a single-stage or two-stage system with provisions to recycle to extinction. The process operates satisfactorily for a variety of feedstocks. The catalysts, which induce desulfurization, denitrogenation, and hydrocracking, are based on both amorphous and molecular-sieve-containing supports.
 - *Advanced partial conversion unicracking (APCU)*. This is a recent advancement in the area of ultralow-sulfur diesel (ULSD) production and feedstock pretreatment for catalytic cracking units.
 - *HyCycle unicracking*. This is designed to maximize diesel production for full-conversion applications.

Moving-Bed Hydroprocessing There are a few types of hydroprocessing reactors with moving catalyst beds in which the catalyst goes in downflow

through the reactor by gravitational forces. In general, catalyst replacement is commonly a batch operation, which is done typically once or twice a week. The fresh catalyst enters at the top of the reactor and the deactivated catalyst leaves the reactor at the bottom, while the hydrocarbon goes either in counter- or co-current flow through the reactor. With this moving-bed system, the catalyst can be replaced either continuously or in batch operation. Catalyst transfer is the most critical section. The countercurrent mode of operation seems to be the best configuration since the spent catalyst contacts the fresh feed at the bottom of the moving-bed reactor while the fresh catalyst reacts with an almost already hydrodemetallized feed at the top of the moving-bed reactor, resulting in lower catalyst consumption.

1. **HYCON PROCESS** The Hycon process is used to improve the quality of residual oils by removing sulfur, metals, and asphaltene constituents and is typically operated in fixed-bed mode, but with increasing metal content in the feedstock, one or more moving-bed “bunker” reactors are added as the leading reactors for HDM. The process is suitable for a wide range of the heavy feedstocks, particularly high in metals and asphaltene constituents. This process enables easy catalyst replacement (to remove or add portions of catalyst) without interrupting operation by means of valves of lock hoppers. The catalyst and heavy oil are fed in co-current flow; the fresh catalyst enters at the top of the reactor and deactivated catalyst is removed from the bottom. The catalyst is replaced at a rate that will ensure a total plant run time of at least a year, which depends on the metal contaminants in the feed. In this way, the bunker reactor technology combines the advantages of plug-flow fixed-bed reactor operation with easy catalyst replacement and provides extra process flexibility if it is used upstream from the desulfurization reactor, especially with reference to the processing of feedstocks with a high metal content. For feeds containing a large amount of metal, metal sulfide can be better accommodated on the catalyst in a bunker-flow reactor than on other reactor systems. Operating conditions and the catalyst addition and withdrawal rates can also be adjusted to ensure that the catalyst taken out is completely spent, while retaining an acceptable average activity in the reactor.

2. **OCR PROCESS** OCR (onstream catalyst replacement) is a moving-bed reactor for hydroprocessing of heavy oils and residua with a significant amount of metals operating in a countercurrent mode at high temperature and pressure. Fresh catalyst is added at the top of the reactor and the feed into the bottom, and both move through the reactor in a countercurrent flow, causing the feed with the highest content of impurities to contact the oldest catalyst first. The fresh catalyst can be added at the top of the reactor and the spent catalyst removed from the OCR reactor while the unit is onstream. An OCR moving-bed reactor can be incorporated in the processing scheme either before or after fixed-bed reactors, so that heavier feeds with higher levels of

contaminants can be processed while maintaining constant the product quality and economical fixed-bed reactor run lengths.

3. **HYVAHL-M** This process employs countercurrent moving-bed reactors and is recommended for feeds containing large amounts of metals and asphaltenes. It requires special equipment and procedures for safe and effective catalyst transfer into and out of the high-pressure unit, similar to the OCR reactor. Catalyst is taken at atmospheric pressure and transferred to a reactor operating under hydrogen pressure, and then the catalyst is taken from the reactor at high operating conditions and discharged to the atmosphere.

Ebullated-Bed Hydroprocessing In ebullated-bed hydroprocessing, the catalyst within the reactor is not fixed. In such a process, the hydrocarbon feed stream enters the bottom of the reactor and flows upward through the catalyst, which is kept in suspension by the pressure of the fluid feed. The hydrocarbon feed and hydrogen are fed upflow through the catalyst bed, expanding and backmixing the bed, and minimizing bed plugging and ΔP . The oil is separated from the catalyst at the top of the reactor and recirculated to the bottom of the bed to mix with the new feed. Alternatively, fresh catalyst is added to the top of the reactor and spent catalyst is withdrawn from the bottom of the reactor.

Ebullating-bed reactors are capable of converting the most problematic feeds, such as AR, VR, and all other heavy oil feedstocks, which have high contents of asphaltenes, metals, and sulfur. Ebullating-bed reactors can perform both HDT and HCR functions; thus, these reactors are referred as dual-purpose reactors. Ebullating-bed catalysts are made of pellets or grains that are less than 1-mm in size to facilitate suspension by the liquid phase in the reactor.

There are three main ebullated-bed processes, which are similar in concept but different in mechanical aspects.

1. *H-Oil*. The H-Oil ebullated-bed process uses a single-stage, two-stage, or three-stage ebullated-bed reactors and can operate over a wide range of conversion levels. It is particularly adapted to process heavy vacuum residues with high metals and Conradson carbon to convert them into distillate products as well as to desulfurize and demetallize feeds to coking units or residue fluid catalytic cracking units, for production of low-sulfur fuel oil or for production in asphalt blending. An H-Oil process maintains constant product properties during cycle length. Since an H-Oil reactor has the unique characteristic of stirred-reactor-type operation with a fluidized catalyst, it has the ability to handle exothermic reactions, solid-containing feedstock, and flexible operation while changing feedstocks or operating objectives.

2. *T-Star*. T-Star is an extension of the H-Oil process which can maintain global conversions in the range 20 to 60% and specifically, an HDS of 93 to 99%. This process can act as an FCC pretreater or vacuum gas oil (VGO) hydrocracker. H-Oil catalyst can be used in the T-Star process. A T-Star reactor

can also be placed in-line with an H-Oil reactor to improve the quality of H-Oil distillate products. In mild hydrocracking mode, the T-Star process can reach conversions up to the 60%, with a catalyst not sensitive to sulfur and nitrogen levels in the feed and will provide constant conversion, product yields, and product quality. This consistency in output is due to the catalyst being replaced while the unit remains online.

3. *LC-Fining*. The LC-Fining ebullated-bed process is a hydrogenation process that can be operated for HDS, HDM, and HCR of atmospheric and vacuum residues. LC-Fining is well suited for extraheavy residue, bitumen, and vacuum residue feedstock HDT and has demonstrated long cycle lengths. The general advantages of LC-Fining are low investment, more light-end recovery, lower operating costs, and lower hydrogen losses. This process yields a full range of high-quality distillates; heavy residue can be used as fuel oil, synthetic crude, or feedstock for RFCC, coker, visbreaker, or SDA. The LC-Fining process can achieve conversions for HDS of 60 to 90%, HDM of 50 to 98%, and CCR reduction of 35 to 80%. The process parameters and reactor design are marginally different from the H-Oil process. The reaction section uses a commercially proven low-pressure hydrogen recovery system. An internal liquid recycle is provided with a pump to expand the catalyst bed continuously. As a result of an expanded bed operating mode, small pressure drops and isothermal operating conditions are accomplished. Small-diameter extruded catalyst particles as small as 0.8mm ($\frac{1}{32}$ in.) can be used in this reactor. Separating the reactor effluent and purifying the recycled hydrogen at low pressure results in lower capital cost and allows design at lower gas rates.

Slurry-Bed Hydroprocessing Slurry-bed reactor can also be used for hydroprocessing of feeds with very high metals content to obtain lower-boiling products using a single reactor. SBR-based technologies combine the advantages of the carbon rejection technologies in terms of flexibility with the high performances peculiar to the hydrogen addition processes. SBR achieves a similar intimate contacting of oil and catalyst and may operate with a lower degree of backmixing than EBR. In contrast to FBR and EBR, in SBR a small amount of finely divided powder is used, which can be an additive or a catalyst (or catalyst precursors). The catalyst is mixed with the feed (heavy oil), and both are fed upward with hydrogen through an empty reactor vessel. Since the oil and catalyst flow co-currently, the mixture approaches plug-flow behavior. In an SBR the fresh catalyst is slurred with the heavy oil prior to entering the reactor, and when the reaction finishes, the spent catalyst leaves the SBR together with the heavy fraction and remains in the unconverted residue in a benign form.

1. *CANMET* Canmet is a hydrocracking process for heavy oils, atmospheric residua, and vacuum residua which was developed to upgrade heavy oil and

tar sand bitumen as well as residua. The process uses an additive to inhibit coke formation, thus allowing high conversion to lower-boiling products using a single reactor. The vertical reactor vessel is free of internal equipment and operates in a three-phase mode. The solid additive particles are suspended in the primary liquid hydrocarbon phase through which the hydrogen and product gases flow rapidly in bubble form. The spent additive leaves with the heavy fraction and remains in the unconverted vacuum residue. Typical operating conditions are a reactor temperature of 440 to 460°C and a pressure of 10 to 15 MPa.

2. MICROCAT-RC The Microcat-RC or M-Coke process is a catalytic ebullated-bed hydroconversion process which operates at relatively moderate pressures and temperatures. The catalyst particles are dispersed uniformly throughout the feed, which results in less distance between particles and less time for a reactant molecule or intermediate to find an active catalyst site. The hydrocarbon feed, microcatalyst, and hydrogen are fed to the reactor. The effluent is sent to a flash separation zone to recover hydrogen, gases, and liquid products. The residuum from the flash step is then fed to a vacuum distillation tower to obtain a 565°C- product oil and a 565°C+ bottoms fraction that contains unconverted feed, microcatalyst, and essentially all of the feed metals.

3. MRH The MRH process is a hydrocracking process designed to upgrade heavy feedstocks containing large amounts of metals and asphaltene, such as VR and bitumen, and to produce mainly middle distillates. The reactor is designed to maintain a mixed three-phase slurry of feedstock, fine powder catalyst, and hydrogen, and to promote effective contact. In the process, a slurry consisting of heavy feedstock and fine powder catalyst is preheated in a furnace and fed into the reactor vessel. From the lower section of the reactor, bottom slurry oil containing the catalyst, uncracked residuum, and a small amount of vacuum gas oil fraction are withdrawn. Vacuum gas oil is recovered in the slurry separation section, and the remaining catalyst and coke are fed to the regenerator.

4. VCC AND HDH PLUS The Veba Combi Cracking (VCC) process is a hydrocracking and hydrogenation process for converting residua and other heavy feedstocks. The VCC technology was transferred to HDH (hydrocracking distillation hydrotreating), which has been developed in parallel by Intevap since 1984. Only the HDH process survives. Recently, Intevap announced the implementation of HDH Plus technology in two refineries in Venezuela: Puerto La Cruz and El Palito. In the process, the heavy feedstock, slurried with a small amount of finely powdered additive and mixed with hydrogen and recycle gas, is hydrogenated (hydrocracked) using a commercial catalyst and liquid-phase hydrogenation reactor operating at 440 to 485°C and 2175 to 4350 psi pressure.

5. ENI SLURRY TECHNOLOGY (EST) The EST process is based on the slurry hydrotreatment of heavy feedstock at relatively low temperature in the presence of hydrogen and a dispersed catalyst, which is recycled to the slurry reactor via solvent deasphalting together with the asphaltene recycle. EST has demonstrated residue conversion of 98 to 99%, HDS > 80%, HDM > 99% and CCR removal > 96% on a small pilot-plant scale. Part of the feedstock is converted directly to light and medium distillates, while the other products represent suitable feedstocks for FCC or hydrocracking. Some of the reported advantages of EST process are feedstock flexibility, optimal hydrogen utilization/consumption, and product slate flexibility.