

## 1

## Modeling

### 1.1 Introduction

This book uses analytical modeling to provide the reader with insights into the fate and transport of solutes in groundwater. In this chapter, we begin by introducing what we mean by analytical modeling, solute transport, and groundwater. We describe models and modeling, define some common modeling terms, and present the fundamental mathematical model that is used to simulate the flow of water in a porous medium. We also include some example model applications, showing how modeling may be used to help us understand the behavior of systems.

To begin, what is a model? Simply put, a model is any approximation of reality, based on simplifications and assumptions. Thus, a model may be a small-scale depiction of reality (a physical model), a mental model or set of ideas/theories as to how reality works (a conceptual model), a network of resistors and capacitors that use electricity to simulate a real system (an analog model), or a set of mathematical equations that are used to describe reality (a mathematical model). In this book, we focus on mathematical models. Specifically, we use partial differential equations (PDEs) to model reality, for as Seife (2000, p. 119) noted in his book *Zero: The Biography of a Dangerous Idea*, "...nature... speaks in differential equations..." Thus, when we subsequently talk about models, we will be talking about one or more PDEs, along with their associated initial and boundary conditions, which, based on various assumptions, are being used to approximate reality.

Having defined what a model is, we need to think about the purpose of modeling; how are models used? Essentially, models have two basic purposes: (1) making predictions and (2) facilitating understanding. Newton's model of gravitational attraction, which allows us to forecast the motion of the planets, and Einstein's model of the mass/energy relationship, which allows us to estimate the energy released in a nuclear explosion, are examples of model applications for predictive purposes. Modeling for understanding, though, is at least as important as using models to make predictions. Especially when

modeling a real system that has many unknowns and much uncertainty associated with it, such as the subsurface, it may be extremely difficult to make good predictions. In a classic study, Konikow (1986) conducted a postaudit to see how satisfactorily a well-calibrated model, based on 40 years of data, predicted the response of water levels in an aquifer to pumping over a subsequent 10-year period. The correlation between observed and model-predicted water levels was “poor.” The study concluded that “...the predictive accuracy of ... models does not necessarily represent their primary value. Rather, they provide a means to assess and assure consistency within and between (1) concepts of the governing processes, and (2) data describing the relevant coefficients. In this manner, a model helps ... improve understanding...” In this book, we focus on the use of modeling to improve understanding. The models presented in later chapters are gross simplifications of reality and have little predictive value, except in a general qualitative sense. However, the model applications that are presented hopefully provide the reader with important insights into how governing processes and parameter values, which quantify the magnitude of those processes, affect the response of chemical contaminants that are being transported in the complex subsurface environment.

We use the classic definition of groundwater: “the subsurface water that occurs beneath the water table in soils and geologic formations that are fully saturated” (Freeze and Cherry, 1979). These geologic strata that contain water are sometimes referred to as aquifers, but the word aquifer is generally reserved for geologic strata that not only contain water but can also transmit or yield appreciable quantities of water. Since the modeling that we are discussing is not predicated on having a minimum transmissivity, we most often refer to the material through which water is flowing simply as a hydrogeologic unit or as a porous medium where we understand that the medium is of geologic origin. The water table is the division between the unsaturated zone and the saturated zone. As we are looking at groundwater, we are concerned with flow below the water table.

Groundwater is not pure water; it contains a variety of solutes, which may occur naturally or be of anthropogenic origin (i.e., human-made). Generally, the majority of the naturally occurring solutes are ionic in form, with natural organic matter concentrations low in comparison. However, much of the current focus on groundwater contamination is due to the presence of hazardous solutes, both organic and inorganic, of anthropogenic origin. The solutes found in groundwater cover a wide range of chemical species. In this text, we take a generic approach, using simple models that simulate the physical, chemical, and biological processes that affect the fate and transport of no particular solute. In this way, we hope the text achieves its goal of providing the reader with insights into how governing processes and parameter values, which quantify the magnitude of those processes, affect the response of chemical contaminants in the subsurface.

## 1.2 Definitions

To make sure we are all speaking the same language, let’s present some terminology that is used throughout this text. We have already defined a **model** as a set of differential equations with boundary and/or initial conditions. We therefore refer to “**the model**” or “**the model equations**”, synonymously. Often, the solution to the model equations is also referred to, imprecisely, as the model. We try to be precise and explicitly refer to the **model solution** (or system response or value of the dependent variable as a function of space and time), rather than using the term model. Similarly, the computer code that is used to obtain the model solution is sometimes referred to as the model. Here, we use the term **model code** to refer to the set of computer instructions or program that is used to solve the model equations. The model code may utilize **analytical**, **semianalytical**, or **numerical** methods to solve the model equations (Javandel et al., 1984). As the title of this book suggests, we present analytical solutions to the model equations. Analytical solutions have a couple of important advantages: (1) they are mathematically exact and do not involve approximating the model equations as numerical methods do and (2) computer codes can evaluate the solutions quickly. The main disadvantage of these analytical solution methods, which was alluded to earlier, is that the model equations and initial/boundary conditions that are being solved must be “simple.” Typically, this means that the PDEs must be linear and that the parameters in the PDEs used to quantify the processes being modeled, as well as the PDE initial and boundary conditions, are either constant or described by simple relationships (e.g., an initial or boundary condition described by a trigonometric function). Such limitations mean that the system that is being modeled is either homogeneous in space and constant in time or else changes in space and time are easy to express mathematically. Obviously, conditions in the subsurface are far from homogeneous or easily expressed, and many processes are most appropriately described by nonlinear equations. Nevertheless, for our purposes (remember, we are focused on using models to gain understanding, not to make predictions), these simplifications are acceptable, and, in fact, helpful.

## 1.3 A Simple Model – Darcy’s Law and Flow Modeling

### 1.3.1 Darcy’s Law

In 1856, Henri Darcy, a French engineer, published his findings that the rate of flow of water through a porous material was proportional to the hydraulic gradient. Hydraulic gradient is defined as the change in hydraulic head ( $h$ ) with distance, where, if one assumes the density of water is constant in space, head

is a measure (in units of length) of the potential energy of water at a point in space. In three dimensions, Darcy's law is

$$\vec{q} = -K\nabla h \quad (1.1)$$

where  $\vec{q}$  [ $L\cdot T^{-1}$ ] is the specific discharge or Darcy velocity, a vector that describes the magnitude and direction of flow per unit area perpendicular to the flow direction,  $\nabla h$  is the hydraulic gradient, a vector describing the magnitude and direction of the steepest change in head with distance ( $\nabla h = \frac{\partial h}{\partial x}\hat{i} + \frac{\partial h}{\partial y}\hat{j} + \frac{\partial h}{\partial z}\hat{k}$  where  $\hat{i}$ ,  $\hat{j}$ , and  $\hat{k}$  are unit vectors in the  $x$ -,  $y$ -, and  $z$ -directions, respectively), and  $K$  [ $L\cdot T^{-1}$ ] is a constant of proportionality, known as the hydraulic conductivity. In the version of Darcy's law shown in Equation (1.1), we are assuming that hydraulic conductivity is a single constant, independent of location (i.e., the porous medium is assumed to be homogeneous) and flow direction (so, the medium is said to be isotropic). More complex versions of Darcy's law allow the value of hydraulic conductivity to vary with both location (a heterogeneous medium) and flow direction (anisotropic medium). Note that for an isotropic medium, Equation (1.1) indicates that the direction of flow is in the direction of the largest *decrease* in hydraulic gradient (hence, the minus sign on the right-hand side of the equation).

We see that Darcy's law is a very simple model, yet it provides us with some important insights. This simple PDE tells us that if we want to predict the direction and magnitude of groundwater flow (which is flow through a porous medium) we need to be able to quantify the hydraulic gradient and hydraulic conductivity. It also tells us that for a given hydraulic conductivity, increasing the gradient by some factor will result in an increase in flow by the same factor; and for a given hydraulic gradient, an increase in conductivity by some factor will increase the flow by the same factor.

It is important to realize that Darcy's law, as every model, has its limits in describing reality. For instance, there are threshold hydraulic gradients, below which there will be insignificant flow and Darcy's law will be inapplicable. And at high gradients, flow may become turbulent and Darcy's law will not apply. Darcy's law is generally assumed to be applicable for laminar flow, where the Reynolds number ( $Re$ ) is less than 1. Reynolds number is a dimensionless quantity defined as

$$Re = \frac{|\vec{q}|d}{\nu}$$

where  $|\vec{q}|$  is the magnitude of the specific discharge,  $d$  is a length scale representative of the system (normally the mean diameter of the porous medium solids or the mean pore dimension), and  $\nu$  is the kinematic viscosity of water [ $L^2T^{-1}$ ].

### 1.3.2 Flow Equation

We can also use Darcy's law to develop other relations (or models). We see that although Equation (1.1) is useful, its application depends on knowing values of hydraulic head at locations within a domain in order to determine the specific discharge at those locations. Equation (1.1) would be even more useful if we had a model that allowed us to derive values of hydraulic head throughout a domain. One of the fundamental principles that are applied to develop models throughout engineering and science is the law of mass conservation, which basically states that mass can neither be created nor destroyed. Let us now use mass conservation, combined with Darcy's law, to derive the main equation of flow, which will allow us to calculate hydraulic heads throughout a domain if we are given heads at boundaries (for a steady-state system, where heads are invariant in time) or if we are given heads at boundaries and heads at a point in time (for a transient system, where heads are changing in time). Once we know the "head field" (the values of hydraulic head throughout a domain), we can then apply Darcy's law to determine the flow field.

Figure 1.1 shows a differential element of porous media of length  $\Delta x$ . We define the porosity of the porous material ( $n$ ) as the volume of void space between the material grains (the pore space), divided by the total volume of the element. Thus, we see  $n$  is dimensionless. In the saturated zone, the void space in the porous media is entirely filled with water. If we define water content ( $\theta$ )

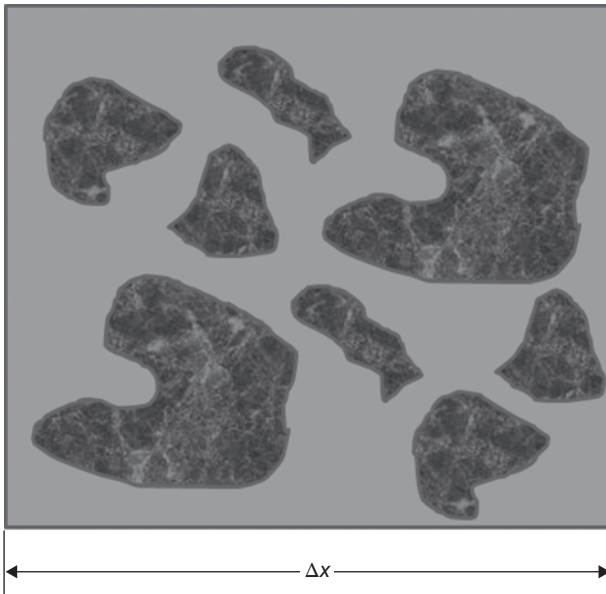
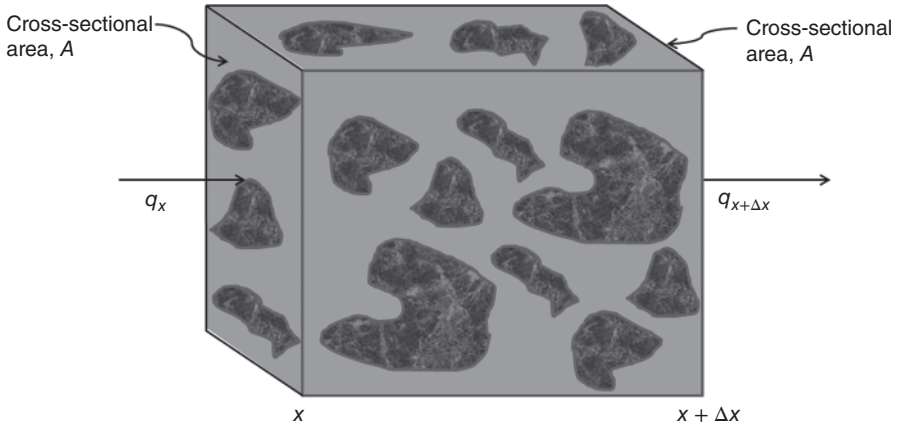

Figure 1.1 Differential element of porous media.



**Figure 1.2** Conservation of mass through a differential element of porous media.

as the volume of water divided by the total volume of the element, we see that in the saturated zone,  $\theta = n$ .

Let us assume one-dimensional water flow in the positive  $x$ -direction through a differential element of length  $\Delta x$  and cross-sectional area perpendicular to the direction of flow  $A$  [ $L^2$ ] (Figure 1.2). Water mass enters and leaves our differential element due to flow in (at specific discharge  $q_x$ ) and flow out (at specific discharge  $q_{x+\Delta x}$ ). Note that we are allowing the specific discharge,  $q$ , to vary in space, so that  $q_x$ , which designates the specific discharge at location  $x$ , is not necessarily the same as  $q_{x+\Delta x}$  which is the specific discharge at location  $x+\Delta x$ . By mass conservation, we know that accumulation of water mass per unit time within the element must equal the mass of water that is entering per unit time minus the mass of water mass that is leaving per unit time. Let us look at each of these terms individually.

First, since the volume of the differential element ( $A \cdot \Delta x$ ) remains constant, the only way water can accumulate within the element is for either the porosity of the medium or the density of the water ( $\rho$ ) [ $M \cdot L^{-3}$ ] to change with time. Thus, we can write the term that describes accumulation of the water within the differential element as  $A \Delta x \frac{\partial(\rho \cdot \theta)}{\partial t}$ . Note that the units of this term are [ $M \cdot T^{-1}$ ].

The mass of water entering the differential element per unit time is the specific discharge of the water into the left face of the element ( $q_x$ ) multiplied by the cross-sectional area through which the water is moving ( $A$ ) multiplied by the water density at location  $x$  ( $\rho_x$ ). Again, units for this term work out to be [ $M \cdot T^{-1}$ ]. Similarly, the mass of water leaving the element per unit time is  $q_{x+\Delta x} A \rho_{x+\Delta x}$ , where  $q_{x+\Delta x}$  and  $\rho_{x+\Delta x}$  are the specific discharge and water density at location  $x+\Delta x$ , respectively. Thus, mathematically, we may write our mass

balance equation as

$$A\Delta x \frac{\partial(\rho\theta)}{\partial t} = q_x A \rho_x - q_{x+\Delta x} A \rho_{x+\Delta x} \quad (1.2)$$

If we assume water is an incompressible fluid, its density is constant in both space and time and we can eliminate  $\rho$  from both sides of the equation. We can subsequently divide both sides of Equation (1.2) by  $A\Delta x$  to obtain

$$\frac{\partial\theta}{\partial t} = \frac{q_x - q_{x+\Delta x}}{\Delta x} \quad (1.3)$$

Taking the limit on the right-hand side of Equation (1.3) as  $\Delta x$  approaches zero gives

$$\frac{\partial\theta}{\partial t} = -\frac{\partial q}{\partial x} \quad (1.4)$$

We may now apply Darcy's law (Equation (1.1)) in one dimension to replace  $q$  on the right-hand side of Equation (1.4) with  $-K \frac{\partial h}{\partial x}$  to obtain

$$\frac{\partial\theta}{\partial t} = K \frac{\partial^2 h}{\partial x^2} \quad (1.5)$$

If we assume the change in water content with time on the left-hand side of Equation (1.5) is proportional to the change in hydraulic head with time, Equation (1.5) becomes

$$S_s \frac{\partial h}{\partial t} = K \frac{\partial^2 h}{\partial x^2} \quad (1.6)$$

where  $S_s$ , the specific storage [ $L^{-1}$ ], defined as the volume of water that a unit volume of aquifer releases from storage under a unit decline in hydraulic head, is a constant of proportionality. For a full discussion of this model, the reader is referred to Domenico and Schwartz (1998).

Finally, if we expand Equation (1.6) to three dimensions, we obtain

$$\frac{\partial h}{\partial t} = \frac{K}{S_s} \left( \frac{\partial^2 h}{\partial x^2} + \frac{\partial^2 h}{\partial y^2} + \frac{\partial^2 h}{\partial z^2} \right) \quad (1.7)$$

This PDE will be called the flow equation for a homogenous isotropic aquifer. Given initial and boundary conditions, and values for the parameters  $K$  and  $S_s$ , it can be solved for hydraulic head as a function of location and time. If the flow is steady state (as is frequently assumed),  $\frac{\partial h}{\partial t} = 0$  and the flow equation becomes

$$0 = \left( \frac{\partial^2 h}{\partial x^2} + \frac{\partial^2 h}{\partial y^2} + \frac{\partial^2 h}{\partial z^2} \right) \quad (1.8)$$

the solution of which does not depend on  $K$  and  $S_s$ . Hydraulic head as a function of location ( $x, y, z$ ) can be found by solving Equation (1.8) for given boundary conditions.

### 1.3.3 Example Application of Darcy's Law and the Flow Equation

Starting with Equation (1.7) or (1.8), let us now develop a model for a particular simple scenario, and use the model to gain understanding about the scenario, as well as to make predictions.

Water is flowing at a steady rate of 1.0 L/min through a 10 m  $\times$  2 m  $\times$  1 m rectangular culvert filled with sand (Figure 1.3). Hydraulic head measurements at the inlet and outlet of the culvert are 9 and 8.9 m, respectively. What is the hydraulic conductivity of the sand?

First, we need to make some assumptions and convert our physical scenario into a conceptual model. Since we are told that hydraulic head only varies along the length of the culvert and does not change with time, let us assume that we can model this as a one-dimensional steady-state system. With no further information, we can assume that the sand is homogeneous. Our conceptual model, then, is of one-dimensional steady water flow through a 10-m-long culvert with a 2 m<sup>2</sup> cross-sectional area.

Having a conceptual model of our physical system, we are now at a point where we can develop a mathematical model. Since we are at steady state, we use Equation (1.8). If we designate our length dimension as  $x$ , Equation (1.8)

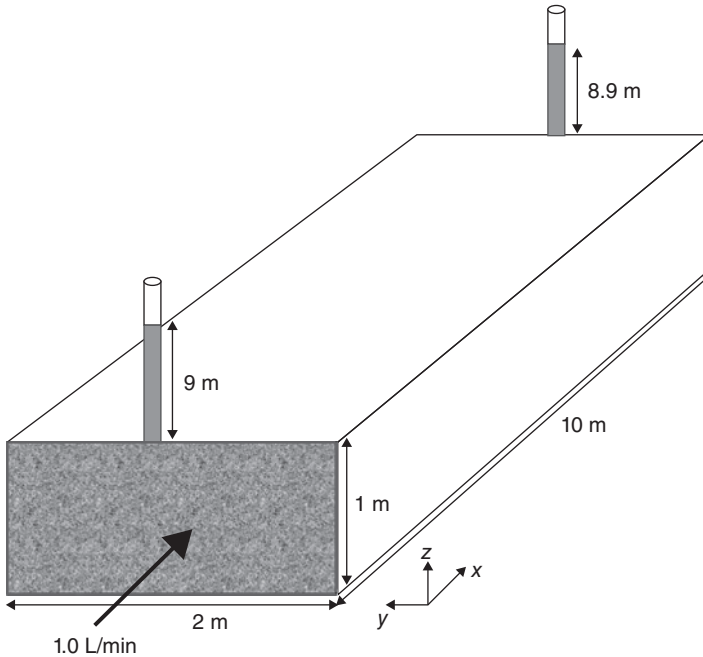

**Figure 1.3** Rectangular culvert filled with sand for example application of Darcy's law and the flow equation.



becomes

$$0 = \left( \frac{d^2 h}{dx^2} \right) \quad (1.9)$$

with boundary conditions

$$h(x = 0 \text{ m}) = 9 \text{ m} \quad (1.9a)$$

$$h(x = 10 \text{ m}) = 8.9 \text{ m} \quad (1.9b)$$

Note that this is an ordinary differential equation, since for the one-dimensional steady-state flow conditions we have postulated, head is only a function of  $x$ . The solution to this ordinary differential equation that satisfies the two boundary conditions is

$$h(x) = 9 \text{ m} - 0.01x \quad (1.10)$$

Equation (1.10) is the solution to our model equation (Equation (1.9)), and it allows us to calculate the hydraulic head (and hydraulic gradient) at any point along the length of the culvert. The solution shows us that we have a linear distribution of the head along the culvert length.

We may now apply Darcy's law to answer the following question: what is the hydraulic conductivity of the sand? Rewriting Equation (1.1) for the one-dimensional system gives

$$K = \frac{-|\vec{q}| \hat{i}}{\hat{i} \frac{\partial h}{\partial x}} \quad (1.11)$$

From Equation (1.10), we know that  $\frac{\partial h}{\partial x} = -0.01$  and by the definition of specific discharge as flow per unit area perpendicular to the flow direction we can calculate  $|\vec{q}| = Q/A = 1.0 \text{ L/min} / 2 \text{ m}^2 * 1 \text{ m}^3 / 1000 \text{ L} * 1 \text{ min} / 60 \text{ s} = 8.33 \times 10^{-6} \text{ m/s}$ .

Finally, applying Equation (1.11) gives us  $K = 8.33 \times 10^{-4} \text{ m/s}$ .

We see that our models (Equations (1.1) and (1.8)) allowed us to find the answer to our question in this very simple case. More importantly, however, the models allow us to understand the system. What happens to flow through the culvert if the hydraulic gradient is doubled? What happens to flow if we replace the sand with gravel having a hydraulic conductivity that is 10 times greater? What would we need to measure to determine sand and gravel hydraulic conductivities if we are told the first half of the culvert is filled with uniform sand and the second half filled with uniform gravel? These questions can all be answered through consideration of the model equations.

### 1.3.4 Note of Caution – Know Model Assumptions and Applicable Conditions

Let us now use our model to derive the well-known equation that describes horizontal flow to a pumping well in an infinite, confined aquifer. A confined

aquifer, also called an artesian aquifer, is an aquifer that is overlain by a low-hydraulic-conductivity confining layer. The water in a confined aquifer is under pressure, as opposed to water in an unconfined (water table) aquifer, where the pressure at the water table is atmospheric (which, by convention, is zero pressure). Thus, recalling that hydraulic head represents the potential energy of water at a location in space, the head in an unconfined aquifer is just the elevation of the water table, while the head in a confined aquifer is the sum of the head due to elevation and the head due to pressure. Figure 1.4 depicts an infinite, confined aquifer of thickness  $B$ , with a pumping well of radius  $r_w$  at radial position  $r = 0$  pumping water out of an aquifer of hydraulic conductivity,  $K$ , at a flow rate  $Q$  [ $L^3 \cdot T^{-1}$ ]. We see that the hydraulic head levels are above the upper confining layer, due to the pressure head.

If we assume the pumping well has been pumping a long time, so that conditions are steady state, we may be tempted to convert our model for steady-state flow (Equation (1.8)) to radial coordinates and apply it to our problem:

$$0 = \left( \frac{d^2 h}{dr^2} \right) \quad (1.12)$$

We immediately see this approach is incorrect. Integrating Equation (1.12), we find that the hydraulic gradient,  $dh/dr$ , should be a constant. If the aquifer is homogenous, so that the hydraulic conductivity,  $K$ , is a constant; application of Darcy's law tells us that the Darcy velocity,  $q$ , is also constant. Clearly, this

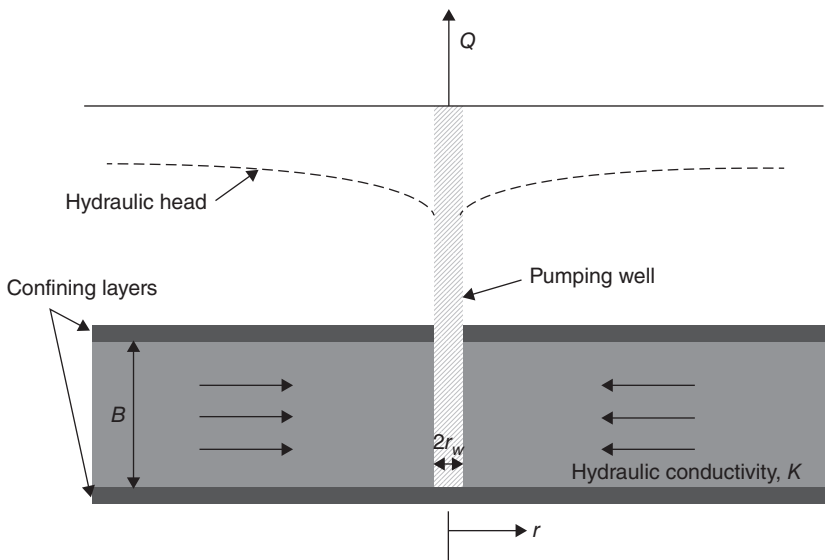

Figure 1.4 Pumping well in an infinite, confined aquifer.

cannot be the case, as we realize that as the water approaches the pumping well and  $r$  gets smaller, the velocity of the water must increase.

So why did our approach fail? The problem is we applied the flow model, which was formulated while assuming certain conditions, under a scenario where those conditions were not valid. In particular, one of the implicit assumptions that were made when deriving the flow model was that the cross-sectional area of the differential element perpendicular to the flow direction at  $x$  is the same as the cross-sectional area at  $x + \Delta x$  (see Figure 1.2, which was used to derive Equation (1.8)). In fact, the annular differential element depicted in Figure 1.5 is relevant to our scenario of a pumping well in an infinite, confined aquifer. For Figure 1.5, the steady-state mass balance equation around the annular differential element is

$$0 = q_{r+\Delta r}\rho_{r+\Delta r}2\pi(r + \Delta r)B - q_r\rho_r2\pi rB \quad (1.13)$$

where  $q_{r+\Delta r}$  and  $q_r$  are the specific discharges at location  $r + \Delta r$  and  $r$ , respectively and  $2\pi(r + \Delta r)B$  and  $2\pi rB$  are the areas of the outer and inner annular surfaces, respectively. Note how the areas at the inflow and outflow faces of the differential element are not the same. Assuming incompressible flow, so that

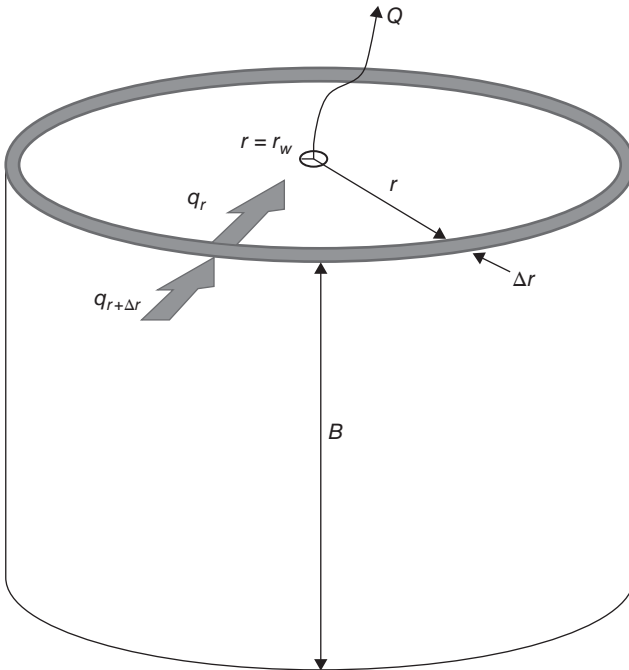

**Figure 1.5** Annular differential element in an infinite, confined aquifer with a pumping well.

$\rho_{r+\Delta r} = \rho_r$ , and letting  $\Delta r \rightarrow 0$ , we obtain the following differential equation:

$$\frac{dq}{dr} + \frac{q}{r} = 0 \quad (1.14)$$

Substituting for  $q$  using Darcy's law in radial coordinates ( $q = -K \frac{dh}{dr}$ ) results in the following second-order homogeneous ordinary differential equation:

$$\frac{d^2h}{dr^2} + \frac{1}{r} \frac{dh}{dr} = 0 \quad (1.15a)$$

For the scenario depicted in Figure 1.4, the following boundary conditions apply:

$$\frac{dh}{dr} = 0 \text{ when } r \rightarrow \infty \quad (1.15b)$$

$$\frac{dh}{dr} = \frac{Q}{2\pi r_w BK} \text{ when } r = r_w \quad (1.15c)$$

Note that the boundary condition (1.15c) is obtained by applying Darcy's law at the well radius, and using mass balance, since the flow into the well through the well screen at  $r = r_w$  (inflow =  $q_{r_w} 2\pi r_w B$ ) must equal  $Q$ . The solution to Equation (1.15) is

$$h = \frac{Q}{2\pi BK} \ln(r) \quad (1.16)$$

Interestingly, this solution, which is mathematically correct, does not make practical sense, since the solution involves determining the natural logarithm of the radial distance,  $r$ , which has dimensions. Thus, the value of  $h$  would depend on the unit of length that is chosen for  $r$ . Therefore, for practical application the solution must be normalized and written as the difference between two heads:

$$h_2 - h_1 = \frac{Q}{2\pi BK} \ln\left(\frac{r_2}{r_1}\right) \quad (1.17)$$

where  $h_2$  and  $h_1$  are heads at distances  $r_2$  and  $r_1$  from the pumping well, respectively. Equation (1.17) is the well-known Thiem solution for steady-state horizontal flow to a pumping well in an infinite, confined, homogeneous aquifer.

In this section, we saw the importance of understanding the assumptions that are made in developing a model and being aware of the conditions upon which the model is applicable. We also saw an approach for testing model results, to see if the model makes sense (i.e., the Equation (1.12) model predicted water would move with a constant Darcy velocity toward a pumping well, which we realized was unrealistic).

### 1.3.5 Superposition (For a Fuller Discussion of Superposition Applied to Groundwater Flow, See Reilly et al., 1984)

The principle of superposition is useful in helping to solve both flow and transport problems. Superposition applies to linear equations, so before discussing the principle of superposition, let us first define what it means for an equation to be linear. An equation (and remember our definition of a model as an equation – oftentimes a differential equation with initial/boundary conditions) is said to be linear if all terms are linear in the dependent variable. Thus, all the models we have discussed in this chapter so far (e.g., Equations (1.1), (1.7), (1.8), and (1.15)) are linear, because the dependent variable,  $h$ , and its derivatives are, in all cases, linear functions. The Boussinesq equation is an example of a nonlinear equation. The following Boussinesq equation models two-dimensional flow in an unconfined aquifer.

$$\frac{\partial h}{\partial t} = \frac{K}{S_s} \left[ \frac{\partial}{\partial x} \left( h \frac{\partial h}{\partial x} \right) + \frac{\partial}{\partial y} \left( h \frac{\partial h}{\partial y} \right) \right]$$

The similarity to Equation (1.7), which models three-dimensional flow in a confined aquifer, is apparent. However, Equation (1.7) is linear since all the terms with the dependent variable  $h$  are linear, whereas the Boussinesq equation is nonlinear in  $h$ , due to terms  $h \frac{\partial h}{\partial x}$  and  $h \frac{\partial h}{\partial y}$ . As an aside, the reason the Boussinesq equation for unconfined flow differs from Equation (1.7) is because Equation (1.7) was derived using the mass balance around the differential element shown in Figure 1.2, where the cross-sectional area perpendicular to the flow direction is constant, whereas for unconfined flow the differential element shown in Figure 1.6 is relevant, so that the areas of the inflow and outflow surfaces are different, due to the difference in aquifer depth at positions  $x$  and  $x + \Delta x$ .

If an equation is linear, so that superposition applies, that means that solutions to the equation can be added together. This principle is perhaps best explained with an example.

### 1.3.6 Example Application of the Principle of Superposition

Consider the scenario depicted in Figure 1.7. Two pumping wells and a monitoring well are installed in a confined, infinite, homogeneous aquifer of 10 m thickness and with no regional flow. Prior to turning on the pumps, the water level (i.e., the hydraulic head) is measured at all three wells and found to be 100 m above sea level (since there is no regional flow, the head must be the same at all locations). After turning on the pumps, the water level drops to 99, 98, and 97.4 m above sea level at pumping wells 1 and 2 and the monitoring well, respectively. What is the hydraulic conductivity of the infinite aquifer?

We saw that Equation (1.17), which describes the head in a confined, infinite, homogeneous aquifer influenced by a pumping well, is the solution to linear

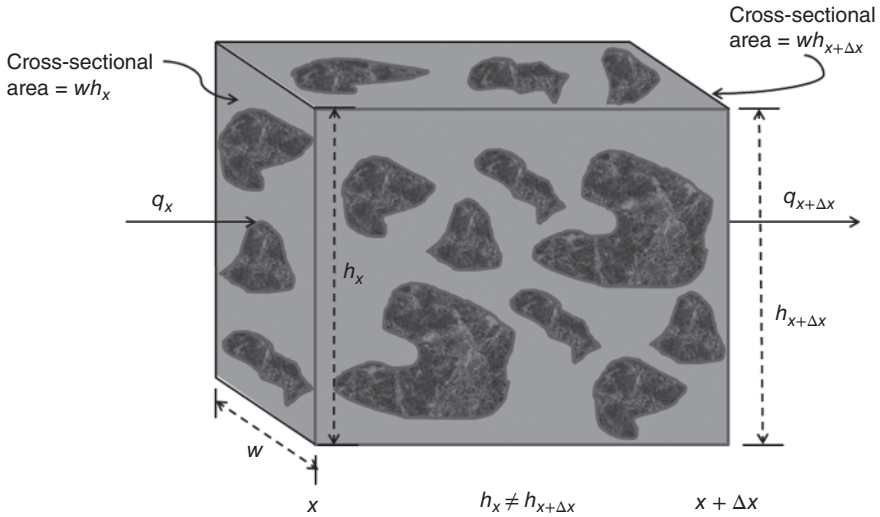

**Figure 1.6** Conservation of mass through a differential element of porous media where the area of inflow to the element does not equal the area of outflow.

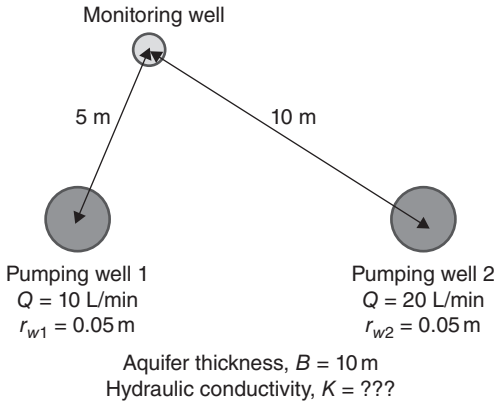

**Figure 1.7** Using the principle of superposition to determine the hydraulic conductivity of an infinite homogeneous aquifer with two pumping wells.

Equation (1.15). Thus, the principle of superposition applies and solutions to Equation (1.15) are additive. Rather than thinking in terms of head, it is perhaps more instructive in this case to think in terms of drawdown, where drawdown is defined as the difference in hydraulic head before and after the pumping wells are turned on. Thus, for this case, the drawdown at the monitoring well is 2.6 m. The principle of superposition allows us to calculate this overall drawdown at the monitoring well ( $s_{mw}$ ) as the sum of the drawdown due to the influence of pumping well 1 ( $s_{mw1}$ ) and the drawdown due to the influence of pumping well 2 ( $s_{mw2}$ ). Thus, if we define  $h_{mw1}$  as the head at the monitoring well only due to

the influence of pumping well 1 and  $h_{mw2}$  as the head at the monitoring well only due to the influence of pumping well 2, we see

$$s_{mw1} = 100 \text{ m} - h_{mw1} \quad \text{and} \quad s_{mw2} = 100 \text{ m} - h_{mw2}$$

We then apply Equation (1.17) to calculate  $h_{mw1}$  and  $h_{mw2}$ :

$$h_{mw1} = h_{w1} + \frac{Q_1}{2\pi BK} \ln \left( \frac{r_{mw1}}{r_{w1}} \right) \quad \text{and} \quad h_{mw2} = h_{w2} + \frac{Q_2}{2\pi BK} \ln \left( \frac{r_{mw2}}{r_{w2}} \right)$$

where  $h_{w1}$  and  $h_{w2}$  are the heads at the well screens (radius =  $r_{w1}$  and  $r_{w2}$ ),  $Q_1$  and  $Q_2$  are the pumping rates, and  $r_{mw1}$  and  $r_{mw2}$  are the distances from the monitoring well to the pumping well, for pumping wells 1 and 2, respectively.

Thus, our final equation for the overall drawdown at the monitoring well is

$$\begin{aligned} s_{mw} &= s_{mw1} + s_{mw2} \\ s_{mw} &= \left\{ 100 \text{ m} - \left[ h_{w1} + \frac{Q_1}{2\pi BK} \ln \left( \frac{r_{mw1}}{r_{w1}} \right) \right] \right\} \\ &\quad + \left\{ 100 \text{ m} - \left[ h_{w2} + \frac{Q_2}{2\pi BK} \ln \left( \frac{r_{mw2}}{r_{w2}} \right) \right] \right\} \end{aligned}$$

Substituting in values for the problem, and converting flow in L/min to  $\text{m}^3/\text{min}$ :

$$\begin{aligned} 2.6 \text{ m} &= \left\{ 100 \text{ m} - \left[ 99 \text{ m} + \frac{0.01 \text{ m}^3/\text{min}}{2\pi(10 \text{ m})K} \ln \left( \frac{5 \text{ m}}{0.05 \text{ m}} \right) \right] \right\} \\ &\quad + \left\{ 100 \text{ m} - \left[ 98 \text{ m} + \frac{0.02 \text{ m}^3/\text{min}}{2\pi(10 \text{ m})K} \ln \left( \frac{10 \text{ m}}{0.05 \text{ m}} \right) \right] \right\} \end{aligned}$$

Solving this single algebraic equation with one unknown for  $K$ , we find  $K = 0.006 \text{ m}/\text{min}$ .

The principle of superposition also means that if the drawdown response to a well pumping at a given rate is  $x$ , the response to a well pumping at twice that rate will be  $2x$ . It also means that a pumping well and an injection well will be mirror images of each other. That is, if pumping at a given rate results in a drawdown of  $y$ , injection at the same rate will result in mounding (increasing the head) of  $y$ .

## Problems

- Given that flow through the culvert in the example in Section 1.3.3 is 1.0 L/min, what is the flow if (a) the hydraulic gradient is doubled and (b) sand is replaced by gravel having a hydraulic conductivity that is 10 times greater?

- 1.2 In the example in Section 1.3.3, assuming the flow through the culvert is still steady at 1.0 L/min, what would we need to measure to determine sand and gravel hydraulic conductivities if we are told the first half of the culvert ( $x = 0-5$  m) is filled with uniform sand and the second half ( $x = 5-10$  m) filled with uniform gravel?
- 1.3 Show that the solution given in Equation (1.16) satisfies differential equation (1.15a) and boundary conditions (1.15b and 1.15c).
- 1.4 Starting with mass balance around an annular differential element, derive a differential equation and boundary conditions analogous to Equation (1.15) for steady flow to a pumping well in an infinite, homogeneous, unconfined aquifer. Keep in mind that for an unconfined aquifer, the height of the differential element through which the water is flowing is not constant, as it was for the confined aquifer depicted in Figures 1.4 and 1.5. The solution to the differential equation and boundary conditions you develop (if done correctly) is sometimes referred to as the Dupuit equation for steady-state flow to a well in an unconfined aquifer.
- 1.5 Is the differential equation derived in Problem 1.4 linear or nonlinear? Does the principle of superposition apply?
- 1.6 Starting with mass balance around the differential element in Figure 1.6, derive the Boussinesq equation.
- 1.7 Change the scenario shown in Figure 1.7 so that pumping well 2 is injecting water at a rate of 20 L/min into the confined, infinite aquifer with a hydraulic conductivity,  $K$ , equal to 0.006 m/min. Calculate the drawdown (or mounding) at the monitoring well. HINT: For injection, the flow rate,  $Q$ , in Equation (1.17) is a negative number. Also, if the drawdown,  $s$ , is negative, it indicates mounding.

## References

- Domenico, P.A. and F.W. Schwartz, *Physical and Chemical Hydrogeology*, 2<sup>nd</sup> Edition, John Wiley and Sons, Inc., New York, 1998.
- Freeze, R.A. and J.A. Cherry, *Groundwater*, Prentice-Hall, Englewood Cliffs, NJ, 1979.
- Javandel, I., C. Doughty, and C.F. Tsang, *Groundwater Transport: Handbook of Mathematical Models* Water Resources Monograph 10, American Geophysical Union, Washington, DC, 1984.



- Konikow, L., Predictive accuracy of a ground-water model—lessons from a postaudit, *Ground Water*, 24(2):173-184, 1986.
- Reilly, T.E., O.L. Franke, and G.D. Bennett, *The principle of superposition and its application in ground-water hydraulics*, U.S. Geological Survey Open File Report 84-459, 1984.
- Seife, C., *Zero: The Biography of a Dangerous Idea*, Penguin Books, New York, 2000.

