

Chapter 1

Introduction

Helical piles are a valuable component in the geotechnical tool belt. From an engineering/architecture standpoint, they can be adapted to support many different types of structures with a number of problematic subsurface conditions. From an owner/developer standpoint, their rapid installation often can result in overall cost savings. From a contractor perspective, they are easy to install and capacity can be verified to a high degree of certainty. From the public perspective, they are perhaps one of the most interesting, innovative, and environmentally friendly deep foundation solutions available today.

This book contains an introduction, a primer on installation and basic geotechnics, advanced topics in helical pile engineering, practical design applications, and other topics. The introduction starts with basic features and components of helical piles. The reason for all the different terms, such as “helical pier,” “helix pier,” “screw pile,” “torque anchor,” and others, is explained through a discussion of terminology. This introductory chapter contains the story of Alexander Mitchell and the invention of the helical pile. Next a brief history of helical pile use is told through an analysis of U.S. patents. Then many modern applications are discussed with the goal of introducing how the helical pile might be applied to everyday projects.

The installation of helical piles is fairly straightforward; however, as with any process, there are a number of tricks of the trade based on years of experience in the installation of helical piles. Many of these tricks are revealed in Chapter 2 along with guidelines for proper installation procedures and equipment. The installation chapter is generally organized as a standard prescription specification with some basic how-to information. Chapter 3 is on basic geotechnics. It contains an overview of some of the basic concepts in soil and rock mechanics that are important for designers and installers of helical piles. These topics include interpretation of exploratory boring logs, soil and rock classification, and shear strength. The soil and rock conditions that

are particularly conducive to helical pile use and those conditions that prohibit helical pile use are discussed.

The engineering of helical piles is broken into seven concepts, which comprise the main technical chapters of this book: Chapter 4 on bearing capacity, Chapter 5 on pullout capacity, Chapter 6 on capacity to torque ratio, Chapter 7 on axial load testing, Chapter 8 on reliability and sizing, Chapter 9 on expansive soil resistance, Chapter 10 on lateral load resistance, and Chapter 11 on corrosion and design life expectancy. These engineering concepts are applied to the practical design of foundations in Chapter 12, earth retention systems in Chapter 13, and underpinning systems in Chapter 14. These technical and design chapters are organized as a handy reference with guide capacity charts, design examples, sample calculations, many references, and real test data.

The book concludes with chapters on nontechnical topics: Chapter 15 on foundation economics, Chapter 16 on proprietary systems, and Chapter 17 on current building codes regarding helical piles. Contained in the appendices are a list of common symbols and abbreviations used in design and construction, a fairly complete list of all U.S. helical pile patents, data from over 275 load tests, a list of the nomenclature used throughout the book, and a glossary of terms pertaining to helical piles. It is intended that this book will appeal primarily to foundation contractors, foundation inspectors, practicing engineers, and architects. It may also serve as a useful supplementary reference to graduate students and university professors in the academic departments of engineering, architecture, and construction.

1.1 BASIC FEATURES

Helical piles are manufactured steel foundations that are rotated into the ground to support structures. The basic components of a helical pile include the lead, extensions, helical bearing plates, and pile cap as detailed in Figure 1.1. The lead section is the first section to enter the ground. It has a tapered pilot point and typically one or multiple helical bearing plates. Extension sections are used to advance the lead section deeper into the ground until the desired bearing stratum is reached. Extension sections can have additional helical bearing plates but often are comprised of a central shaft and couplings only. The couplings generally consist of bolted male and female sleeves. The central shaft is commonly a solid square bar or a hollow tubular round section.

Helical piles have been used in projects throughout the world. Uses for helical piles include foundations for houses, commercial buildings, light poles, pedestrian bridges, and sound walls to name a few. Helical piles also are used as underpinning elements for repair of failed foundations or to augment existing foundations for support of new loads. Helical piles can be installed horizontally or at any angle and can support tensile in addition to compressive loads. As a tensile member, they are used for retaining wall systems, utility guy anchors, membrane roof systems, pipeline buoyancy control, transmission towers, and many other structures.

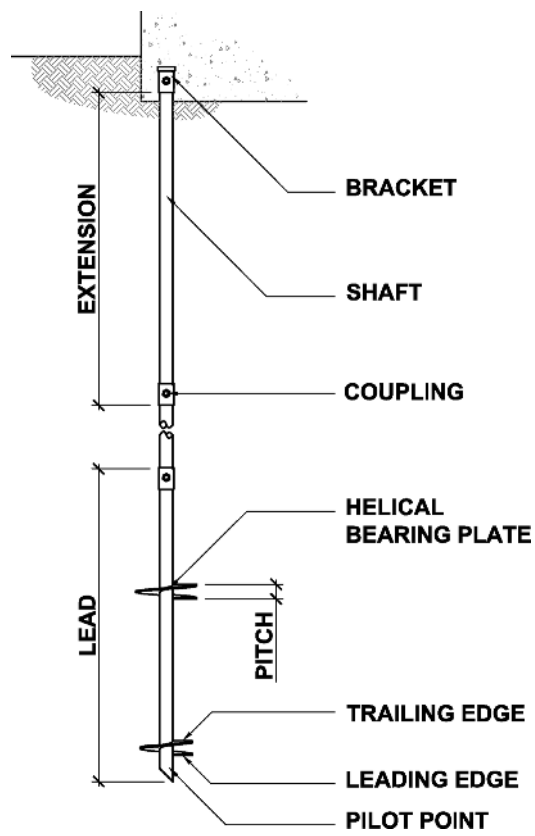

Figure 1.1 Basic helical pile

Helical piles offer unique advantages over other foundation types. Helical pile installation is unaffected by caving soils and groundwater. Installation machinery has more maneuverability than pile-driving and pier-drilling rigs. Installation can even be done with portable, hand-operated equipment in limited access areas such as inside crawl spaces of existing buildings. A photograph of a limited access rig working inside the basement of a commercial building is shown in Figure 1.2. Helical pile installation does not produce drill spoil, excessive vibrations, or disruptive noise. Installation of a new foundation system consisting of 20 helical piles is conducted in typically less than a few hours. Loading can be immediately performed without waiting for concrete to set. Helical piles can be removed and reinstalled for temporary applications, if a pile is installed in an incorrect location or if plans change. A summary of these and other advantages of helical piles is given in Table 1.1. Helical piles are practical, versatile, innovative, and economical deep foundations. Helical piles are an excellent addition to the variety of deep foundation alternatives available to the practitioner.



Figure 1.2 Helical pile installation in limited access area (Courtesy of Earth Contact Products, Inc.)

Table 1.1 Benefits of Helical Piles

Resist scour and undermining for bridge applications
Can be removed for temporary applications
Are easily transported to remote sites
Torque is a strong verification of capacity
Can be installed through groundwater without casing
Typically require less time to install
Can be installed at a batter angle for added lateral resistance
Can be installed with smaller more accessible equipment
Are installed with low noise and minimal vibrations
Can be grouted in place after installation
Can be galvanized for corrosion resistance
Eliminate concrete curing and formwork
Do not produce drill spoil
Minimize disturbance to environmentally sensitive sites
Reduce the number of truck trips to a site
Are cost effective

1.2 TERMINOLOGY

There is often some question as to whether a helical foundation should be considered a pile or a pier. In some parts of the United States, especially the coastal areas, the terms “pile” and “pier” are used with reference to different foundations based on their length. As defined in the International Building Code (2006), a “pile” has a length equal to or greater than 12 diameters. A “pier” has a length shorter than 12 diameters. In other parts of the United States, specifically Rocky Mountain regions, the terms “pile” and “pier” are defined by the installation process. A pier is drilled into the ground, whereas a pile is driven into the ground. Some European foundation engineering textbooks explain that a pier is a type of pile with a portion that extends aboveground, as in the case of marina piers. Geographic differences in definitions of the same terms often create considerable confusion at national and international meetings and conferences. Before attempting a technical discussion, definitions should be clearly stated and agreed on.

The original device that is the precursor to the modern-day helical pile was termed the “screw pile.” Sometime later, the phrase “helical anchor” became more common, probably because the major application from 1920 through 1980 was for tension. In about 1985, one of the largest manufacturer’s of helical anchors, the AB Chance Company, trademarked the name “helical pier” in order to promote bearing or compression applications. In the last 20 years, other manufacturers attempting to avoid the trade name have promoted terms such as “helix pier,” “screw pier,” “helical foundation,” “torque anchor,” and others. The Canadian building code uses the phrase “augered steel pile.” The terms “heli-coils” and even “he-lickers” are heard in isolated regions.

Given that most helical piles are typically installed to depths greater than 12 diameters and the trade name issues, the Helical Foundations and Tie-Backs committee of the Deep Foundation Institute decided in 2005 to henceforth use the phrase “helical pile.” This is the name that will be used throughout this text. “Helical pile” is defined below. Other terms related to helical piles and foundations in general are defined in the Glossary of Terms.

Helical Pile (noun) “A manufactured steel foundation consisting of one or more helix-shaped bearing plates affixed to a central shaft that is rotated into the ground to support structures.”

Since they can resist both compression and tension, helical piles can be used as a foundation or as an anchor. The phrase “helical pile” is generally used for compression applications, whereas the phrase “helical anchor” is reserved for tension applications. The devices themselves are the same. The phrase “helical pile” is used herein for the general case unless the distinction between applications is a necessary clarification.

1.3 INVENTION

The first recorded use of a helical pile was in 1836 by a blind brickmaker and civil engineer named Alexander Mitchell. Mitchell was born in Ireland on April 13, 1780, and attended Belfast Academy. He lost his sight gradually from age 6 to age 21. Being blind limited Mitchell's career options, so he took up brick making during the day and studied mechanics, mathematics, science, and building construction in his leisure. One of the problems that puzzled Mitchell was how to better found marine structures on weak soils, such as sand reefs, mudflats, and river estuary banks. At the age of 52, Mitchell devised a solution to this problem, the helical pile. The author Irwin Ross (Hendrickson, 1984 pp. 332–333) describes Mitchell's moment of invention in this way:

Necessity is often cited as the mother of invention, but in the case of Mitchell's invention it may be said that it was incubated by his love for mankind and actually discovered by accident.

In the early 1830s, there were many storms. During the long October and November nights, at the beginning of this period, Mitchell lay in bed listening to the raging storms outside, which violently shook the window sashes, made the slates drum, howled in the chimney, and seemed at the retreat of every gust a requiem for those poor mariners whose dead bodies he pictured being swept on the crest of an angry sea.

Mitchell lay thinking. He could only sleep in brief snatches. Something had to be done, and he resolved to do it. Many original ideas occurred to him regarding lighthouse foundations on sandy beds, but in practice they proved to be unsuccessful.

One day in 1832, when experimenting with a sail which he had made to enable a boat to sail in the teeth of the wind by means of a broad-flanged screw in the water and a canvas-covered screw in the air, he happened to place the water screw on the ground, and a great gust of wind, violently propelling the aerial canvas screw, embedded that water screw firmly in the ground.

Mitchell tugged at the connecting spindle, and then his nimble fingers traveled toward the earth, his sense of touch disclosing what had taken place. He sprang upright and danced around his discovery with delight. He had discovered the principle of the screw pile.

One evening he hired a boat, and with his son John as boatman, he steered his course to a sandy bank in Belfast Lough, where he planted a miniature screw pile. He then returned home, no one being any wiser about his experiment. Very early the next morning, before the working world was astir, they rowed out again, examined the pile, and found it firmly fixed where they had placed it, although the sea that night had been a bit rough. This was a moment of great satisfaction to both father and son.

In 1833, Mitchell patented his invention in London. Mitchell called the device a "screw pile" and its first uses were for ship moorings. A diagram of Mitchell's screw pile is shown in Figure 1.3. The pile was turned into the ground by human and animal power using a large wood handle wheel called a capstan. Screw piles on the order



Figure 1.3 Mitchell screw pile

of 20 feet [6 m] long with 5-inch- [127-mm-] diameter shafts required as many as 30 men to work the capstan. Horses and donkeys were sometimes employed as well as water jets.

In 1838, Mitchell used screw piles for the foundation of the Maplin Sands Lighthouse on a very unstable bank near the entrance of the river Thames in England. A profile view of the Maplin Sands Lighthouse is shown in Figure 1.4. The foundation consisted of nine wrought-iron screw piles arranged in the form of an octagon with one screw pile in the center. Each pile had a 4-foot [1.2 m] diameter helix at the base of a 5-inch [127 mm] diameter shaft. All nine piles were installed to a depth of 22 feet [6.7 m], or 12 feet [3.7 m] below the mud line, by human power in nine consecutive days. The tops of the piles were interconnected to provide lateral bracing (Lutenegger, 2003).

Author Irwin Ross (Hendrickson, 1984, pp. 332–333) explained how valuable the invention of the helical pile was to lighthouse construction.

The erection of lighthouses on this principle caused the technical world to wonder. This invention, which has been the means of saving thousands of lives and preventing the loss of millions of dollars worth of shipping, has enabled lighthouses and beacons to be built



Figure 1.4 Maplin Sands lighthouse

on coasts where the nature of the foreshore and land formations forbade the erection of conventional structures. The screw pile has been used in the construction of lighthouses and beacons all over the world, and it earned for Mitchell and his family a large sum.

...Although Mitchell was blind, he never failed to visit his jobs, even in the most exposed positions, during rough weather. In examining the work, he always crawled on his hands and knees over the entire surface, testing the workmanship by his sense of

touch... On many occasions he stayed out the whole day, with a few sandwiches and a flask, cheering his men at their work and leading them in sea songs as they marched around on the raft driving the screws.

In 1853, Eugenius Birch started using Mitchell's screw pile technology to support seaside piers throughout England. The first of these was the Margate Pier. From 1862 to 1872, 18 seaside piers were constructed on screw piles. Photographs of three of these piers, the Eastbourne Pier, Bournemouth Pier, and the Palace Pier are shown in Figure 1.5. As can be seen in the figure, each bridge pier consisted of a series of interconnected columns. Each of these columns was supported on a screw pile. The piers themselves supported the weight of pedestrians, carts, buildings, and ancillary structures. The foundations had to support tidal forces, wind loads, and occasional ice flows. Screw piles also were used to support Blankenberg Pier in Belgium in 1895 (Lutenegger, 2003).

During the expansion of the British Empire, screw piles were used to support new bridges in many countries on many continents. Technical articles were published in *The Engineering and Building Record* in 1890 and in *Engineering News* in 1892 regarding bridges supported on screw piling. Excerpts from these journal articles are shown in Figure 1.6. The foundations for the bridges shown look very similar to those used to support seaside piers. Screw piles were installed in groups and occasionally at a batter angle. Pier shafts were braced with horizontal and diagonal members above the mud line. Notably, concrete is absent from the construction of these foundations. As a result of British expansion, screw piles were soon being applied around the world (Lutenegger, 2003).

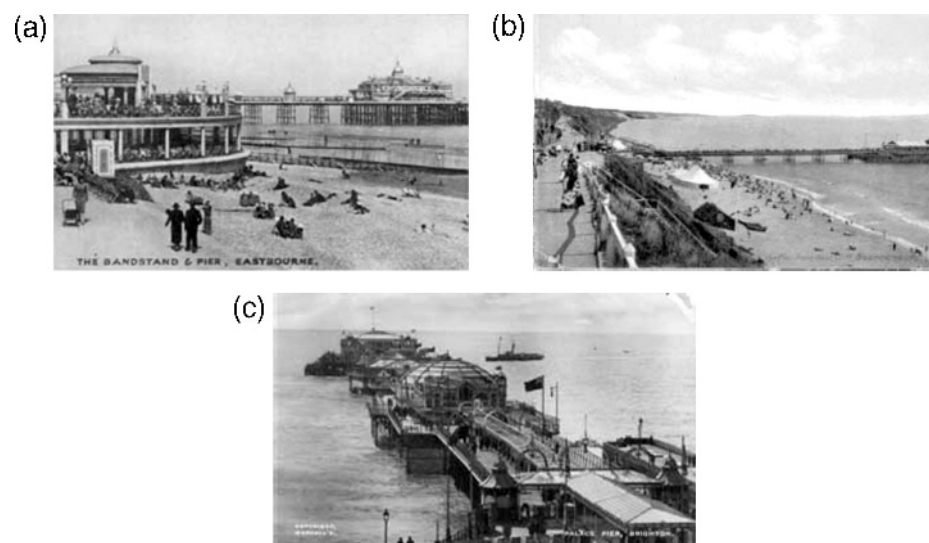

Figure 1.5 Oceanside piers supported by helical piles: (a) Eastbourne Pier; (b) Bournemouth Pier; (c) Palace Pier

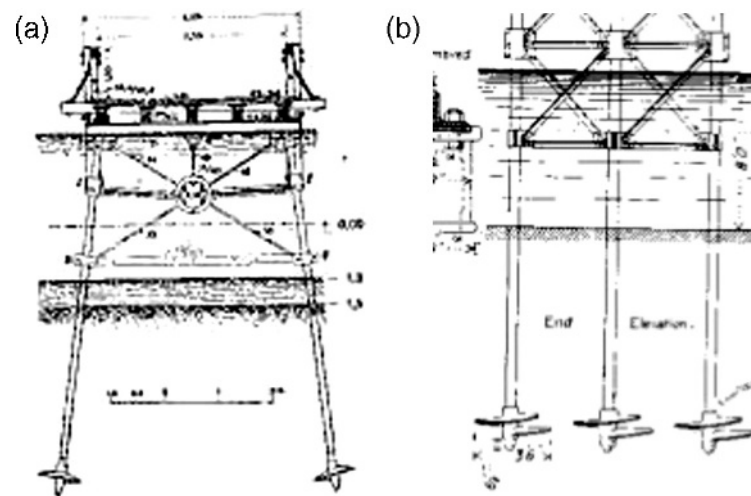
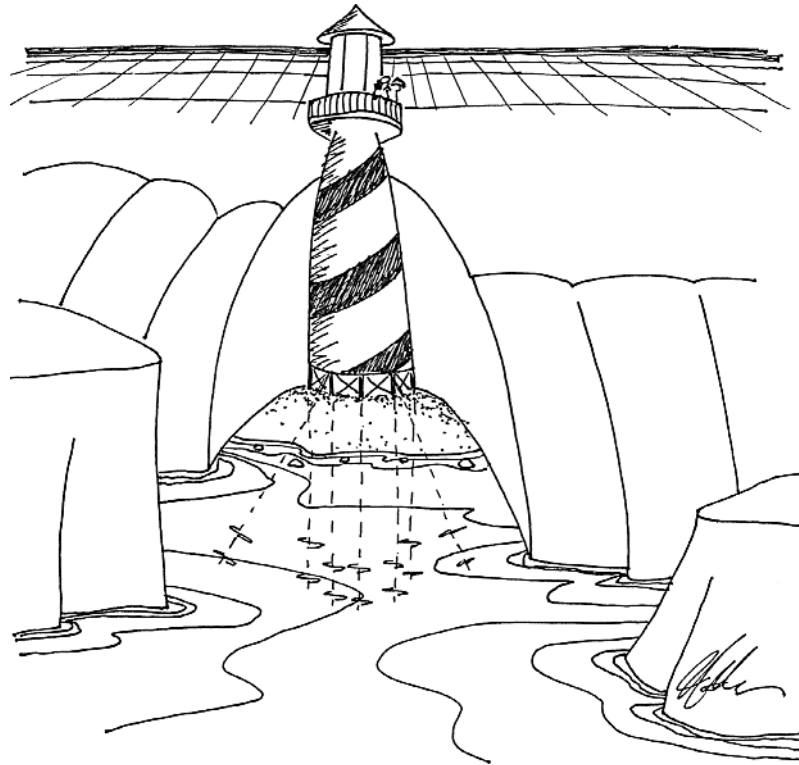

Figure 1.6 Early helical pile supported bridges.
 “Screw Pile Bridge over the Wumme River,” *Engineering and Building Record*, April 5, 1890;
 “Screw Piles for Bridge Piers,” *Engineering News*, August 4, 1892.

There is some controversy as to the first known use of a helical pile in the United States. According to Lutenecker (2003), Captain William H. Swift constructed the first U.S. lighthouse on screw piles in 1843 at Black Rock Harbor in Connecticut. According to the National Historic Landmark Registry (NPS, 2007), Major Hartman Bache, a distinguished engineer of the Army Corps of Topographical Engineers, completed the first screw pile lighthouse at Brandywine Shoal in Delaware Bay in 1850. In both cases, Alexander Mitchell sailed to North America and served as a consultant.

In the 1850s through 1890s, more than 100 lighthouses were constructed on helical pile foundations along the East Coast of the United States and along the Gulf of Mexico. Examples of screw pile lighthouses in North Carolina include Roanoke River (1867), Harbor Island Bar (1867), Southwest Point Royal Shoal (1867), Long Point Shoal (1867), and Brant Island (1867). Other examples of screw pile lighthouses include Hooper Strait (1867), Upper Cedar Point (1867), Lower Cedar Point (1867), Janes Island (1867), and Choptank River (1871) in Maryland and White Shoals (1855), Windmill Point (1869), Bowlers Rock (1869), Smith Point (1868), York River Spit (1870), Wolf Trap (1870), Tue Marshes (1875), and Pages Rock (1893) in Virginia. Screw pile lighthouses also were built in Florida at Sand Key and Sombrero Key. Many of the lighthouse foundations in the Northeast were required to resist lateral loads from ice flows and performed considerably better than straight shaft pile foundations. Most historic lighthouses have been destroyed or disassembled. A screw pile lighthouse still in existence is Thomas Point Shoal Light Station (NPS, 2007).



“I’m glad we installed that helical pile foundation before the glacier hit.”

The first technical paper written on helical piles was “On Submarine Foundations; particularly Screw-Pile and Moorings,” by Alexander Mitchell, which was published in the *Civil Engineer and Architects Journal* in 1848. In this paper, Mitchell stated that helical piles could be employed to support an imposed weight or resist an upward strain. He further stated that a helical pile’s holding power depends on the area of the helical bearing plate, the nature of the ground into which it is inserted, and the depth to which it is forced beneath the surface.

From about 1900 to 1950, the use of helical piles declined. During this time, there were major developments in mechanical pile-driving and drilling equipment. Deep foundations, such as Raymond drilled foundations, belled piers, and Franki piles, were developed. With the development of modern hydraulic torque motors, advances in manufacturing, and new galvanizing techniques, the modern helical pile evolved primarily for anchor applications until around 1980 when engineer Stan Rupiper designed the first compression application in the U.S. using modern helical piles (Rupiper, 2000).

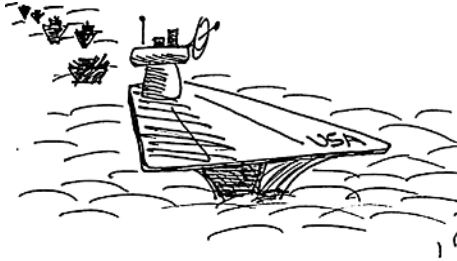

Radio conversation of a U.S. naval ship with Canadian authorities off the coast of Newfoundland in October 1995.

CANADIANS: "Please divert your course 15 degrees to the north to avoid a collision."

AMERICANS: "Recommend YOU divert your course 15 degrees to the south to avoid a collision."

CANADIANS: "Negative. You will have to divert your course 15 degrees to the north to avoid a collision."

AMERICANS: "This is the captain of a US Navy ship. I say again, divert YOUR course"

CANADIANS: "No, I say again, you divert your course"

AMERICANS: "This is the Aircraft Carrier USS LINCOLN, the second largest ship in the United States Atlantic Fleet. We are accompanied with three Destroyers, three Cruisers and numerous support vessels. I DEMAND that you change your course 15 degrees south, or counter-measures will be undertaken to ensure the safety of this ship"

CANADIANS: "This is a LIGHTHOUSE on a helical foundation. Your call."

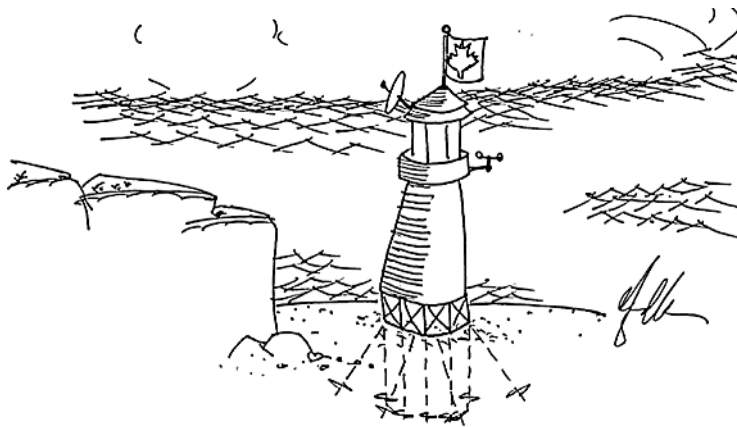

1.4 EARLY U.S. PATENTS

There are more than 160 U.S. patents for different devices and methods related to helical piles (see Chapter 16 and Appendix B). One of the earliest patents filed shortly after the first lighthouse was constructed in the U.S. on helical piles was by T.W.H. Moseley. Moseley's patent described pipe sections coupled together with flanges. The lead pipe section was tapered with a spiral section of screw threads and an optional spade point as shown in Figure 1.7. Another aspect of the invention, shown in Figure 1.8, consisted of a wooden pile driven through the center of the screw pile and concrete filling the annular space. The screw portion of the pile is shown installed below the mud line. The bottom most flange rests at the mud line. Historic documents indicate that

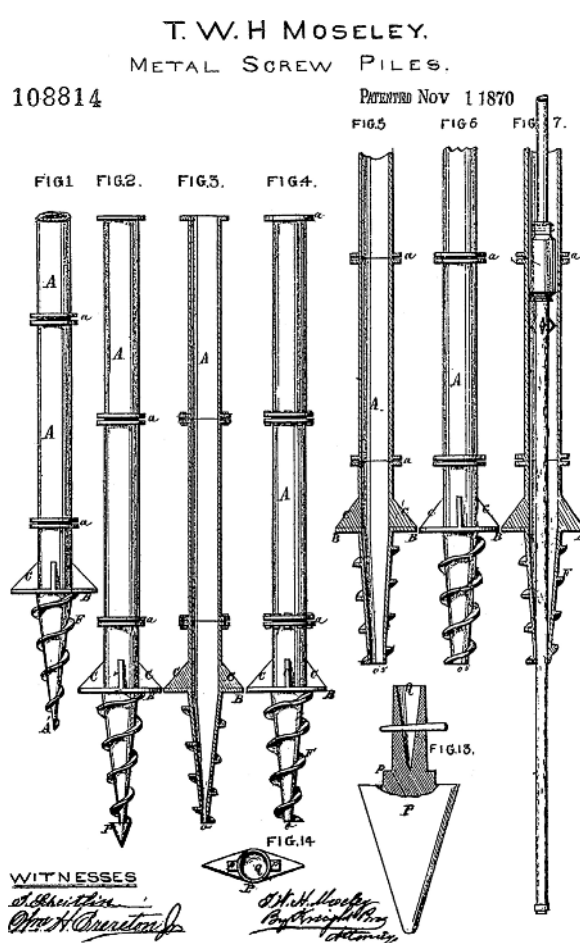

Figure 1.7 Moseley helical pile patent

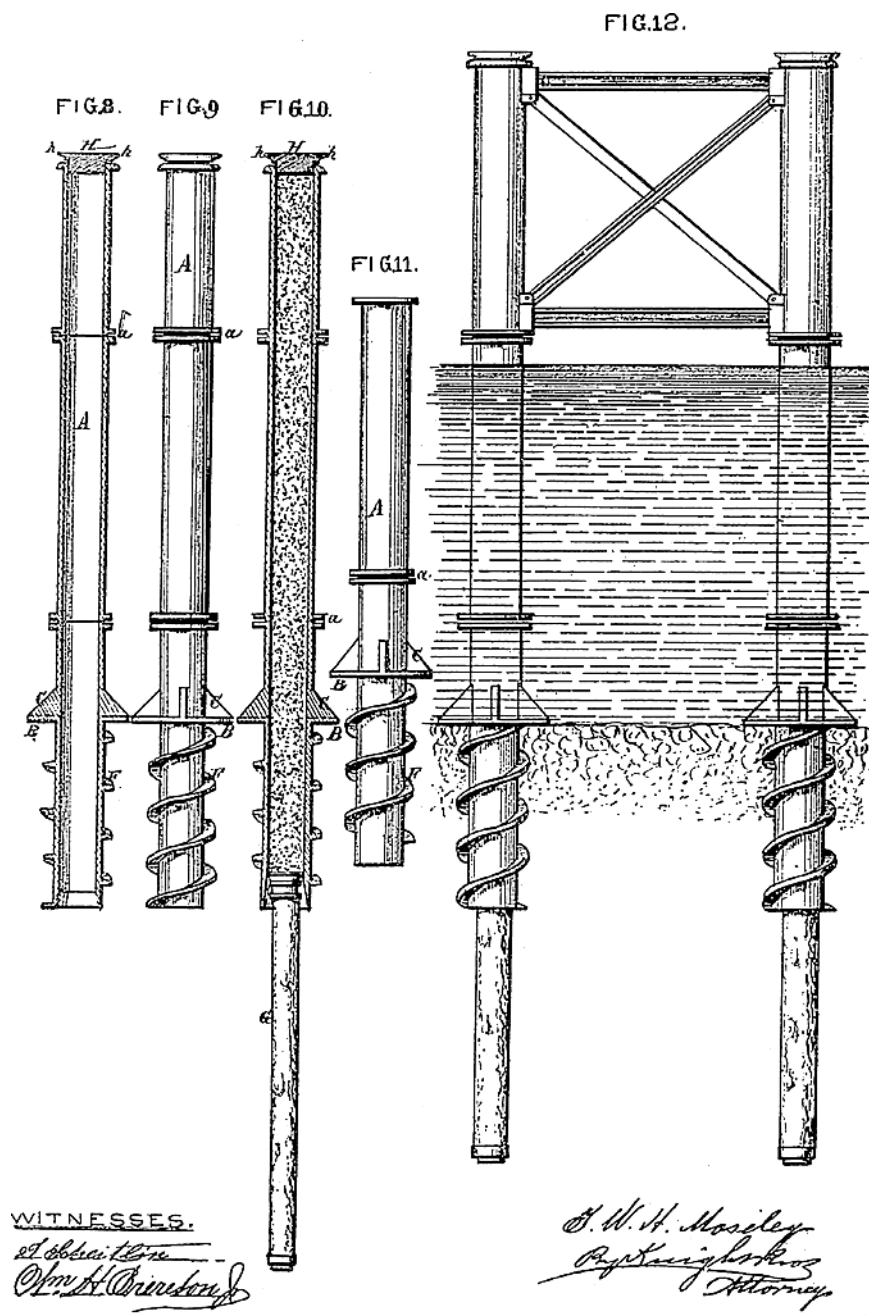

Figure 1.8 Moseley helical pile patent (Cont.)

this method of combining driven piles with screw piles was used to construct a number of marine structures in the 1800s (NPS, 2007).

Although Moseley described using concrete to fill the inside of a helical pile, the first use of pressurized grouting on the exterior of a helical pile was by Franz Dyche in 1952. As shown in Figure 1.9, Dyche explained that a lubricating fluid or grout could be pumped through openings at each screw flight spaced along the helical pile lead section. Dyche's helical pile consisted of a lead section with bearing plates in a continual spiral over the length of the lead. The lead section could be extended in depth by one or more tubular extensions. A guy wire or other anchor cable could be attached to a flange at the top of the lead section. The installation tooling could be removed after the appropriate depth is obtained. It was determined later by others that group effects within soil make the continuous spiral unnecessary and that single helical bearing plates spaced along the length of a lead can match the capacity of a continuous spiral in soil.

One of the first U.S. patents on helical ground anchors can be credited to A.S. Ballard of Iowa, who in 1860 patented what he called an earth borer. In later patents, Ballard's device is referred to as an earth anchor. The device, shown in Figure 1.10, had two helix-shaped plates with a solid steel shaft and conical pilot point. The helical plates are riveted to a cross bar attached to the shaft. Ballard's patent was followed by forty variations in helical anchors over the next one hundred years. One variation, which occurred 15 years after Ballard's patent issue date, was a similar anchoring device by Clarke. Clarke's device, shown in Figure 1.11, differed from that of Ballard in that the pitch of the helical plates was increased and the installation tool was made detachable so that a section of pipe with guy wire eyelet could be inserted after anchor installation.

Patents have been filed for helical anchors with different shaped installation tools including L-shape, S-shape, square, round, and cruciform shaft sockets. Many patents for helical anchors regard special spade-shaped and corkscrew pilot points for penetrating difficult soils. There also are many patents regarding the shape of the helix and its cutting edge. Most of these early patents for helical anchors are more than 25 years old and are now public domain.

Many of the U.S. patents for helical piles involve different methods for supporting structures. An example, depicted in Figure 1.12, involves the hold down of pipelines for buoyancy control. When a partially full pipeline is submersed below open water or in groundwater, it is subject to a significant upward force due to buoyancy. In the example, Hollander describes a method of simultaneously installing two helical anchors rotating in opposite directions using a crane mounted drilling apparatus. The opposite direction of rotation of the anchors during installation eliminated any net rotation force on the suspended drills. This method of anchor installation for buoyancy control patented in 1969 is still used today.

Another notable application of helical piles is for underpinning existing structures. Underpinning is used to repair failed foundations or to support new loads. In 1991, Hamilton and others from the A.B. Chance Company patented a method of installing a steel underpinning bracket under an existing foundation and screwing a helical pile

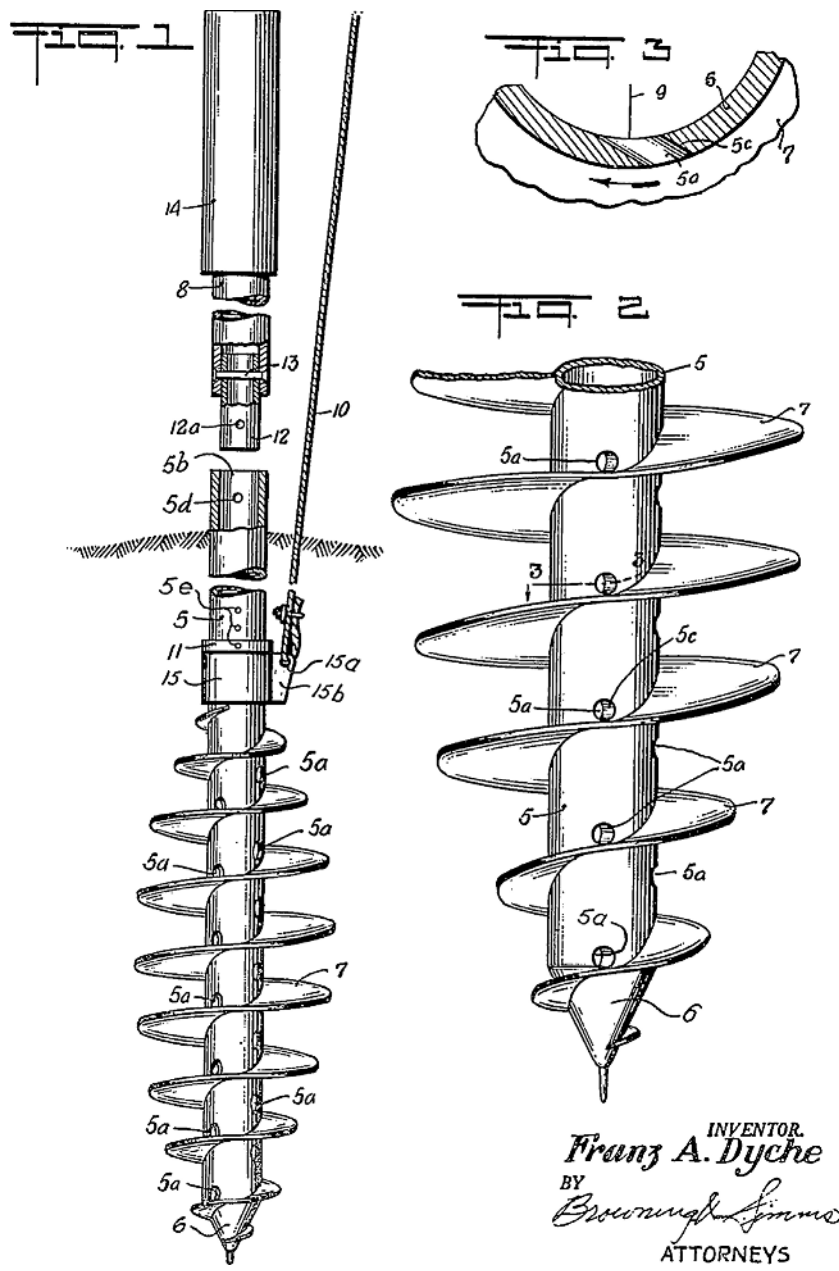

Figure 1.9 First helical pile grouting method

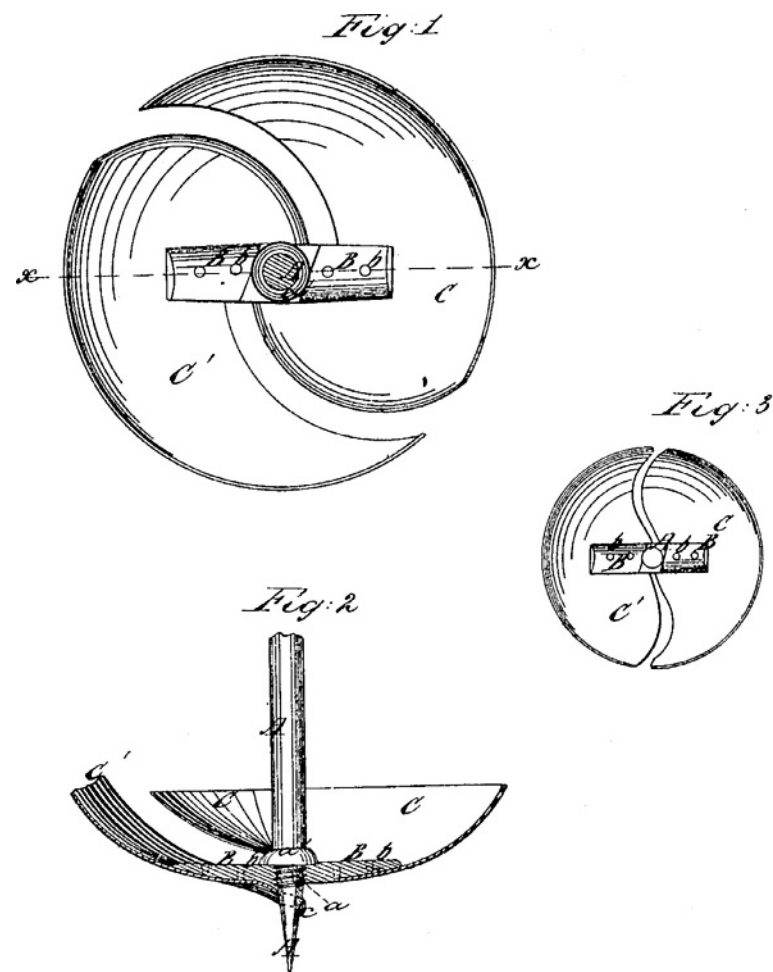

Figure 1.10 Ballard earth-borer device

at a slight angle directly adjacent to the bracket as pictured in Figure 1.13. The helical pile and bracket are used to lift and permanently support the foundation. A legal battle ensued between the patent holders and helical pile installers led by Richard Ruiz of Fast Steel, a competing helical pile manufacturer. Ruiz challenged the originality and novelty of the patent claims. After many appeals, the claims of Hamilton's patent were overturned. It is no longer proprietary to underpin existing foundations using helical piles. A flurry of patents regarding different underpinning brackets followed in the last decade. Despite the loss of their patent rights, much credit is owed to Hamilton and the A.B. Chance Company for advancing the state of the art with respect to helical piling for underpinning.

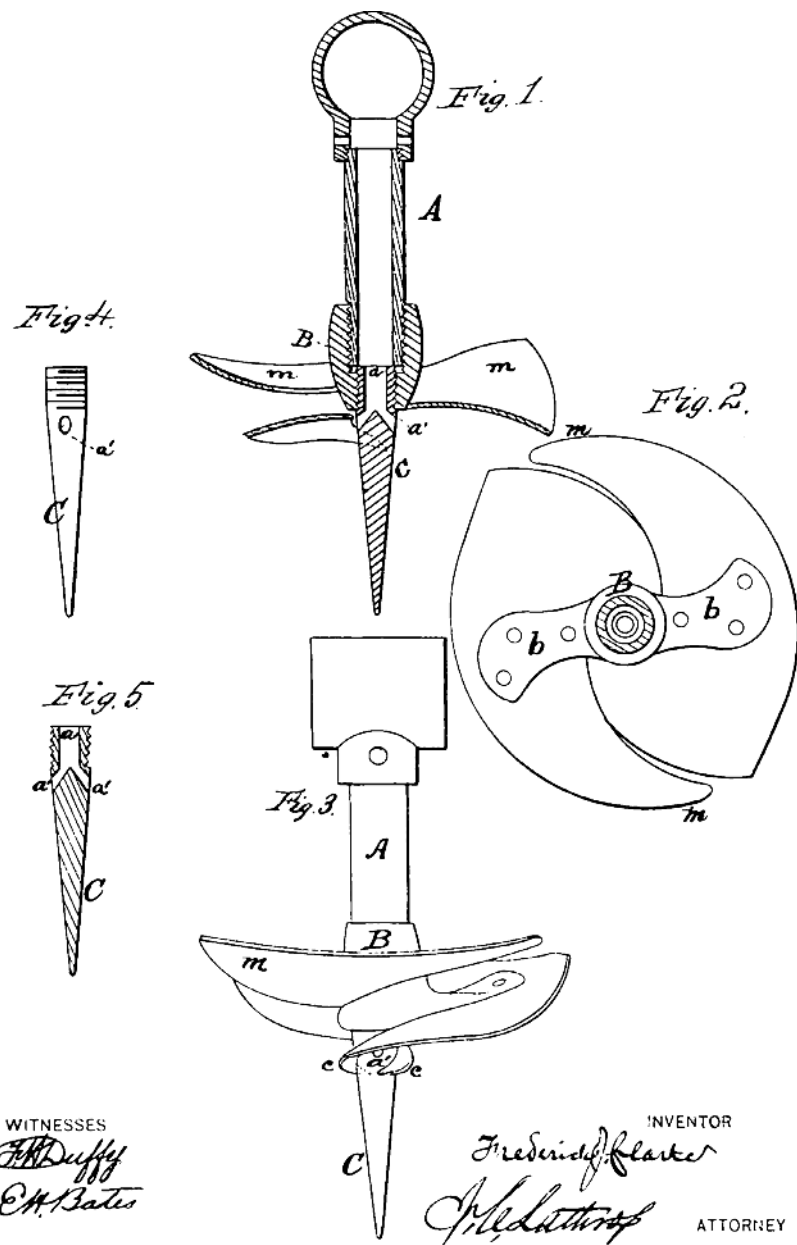

Figure 1.11 Clarke anchor device

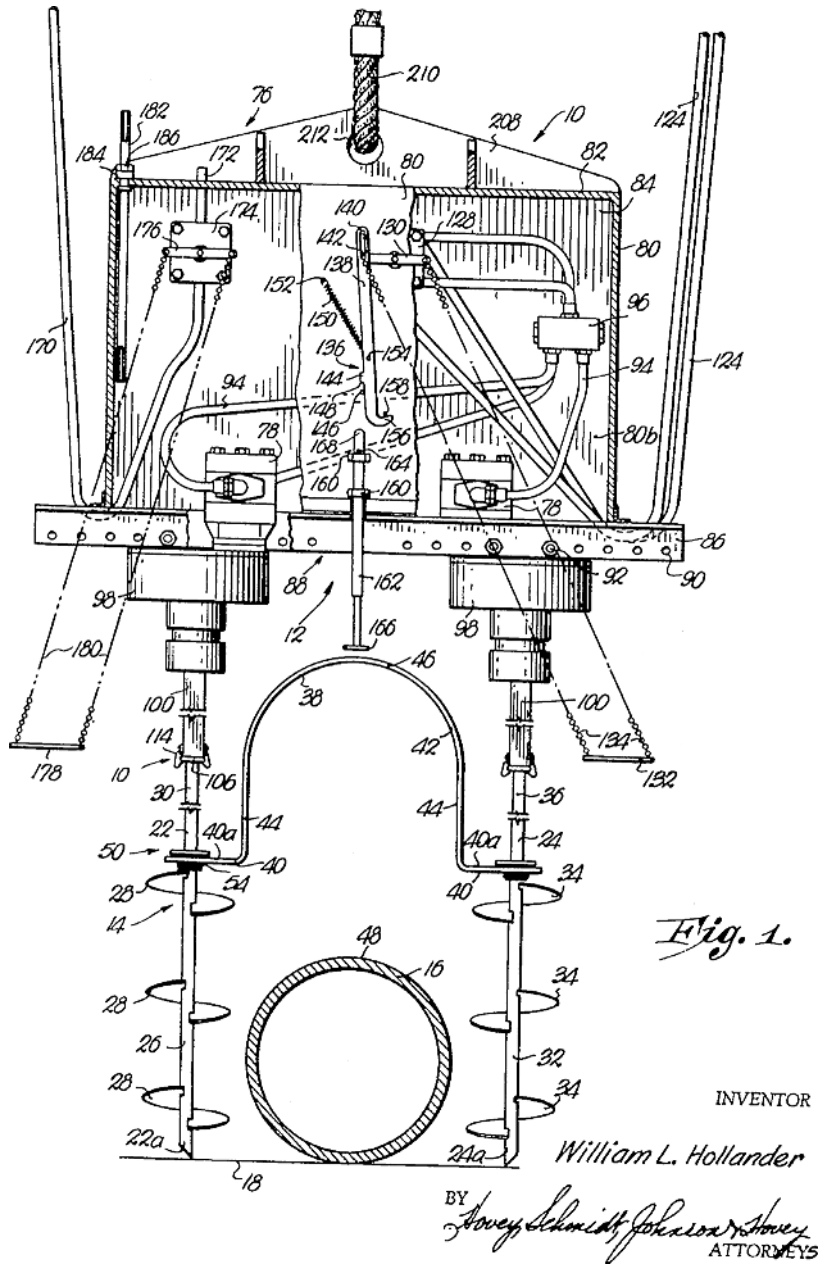

Figure 1.12 Hollander pipeline anchor installation method

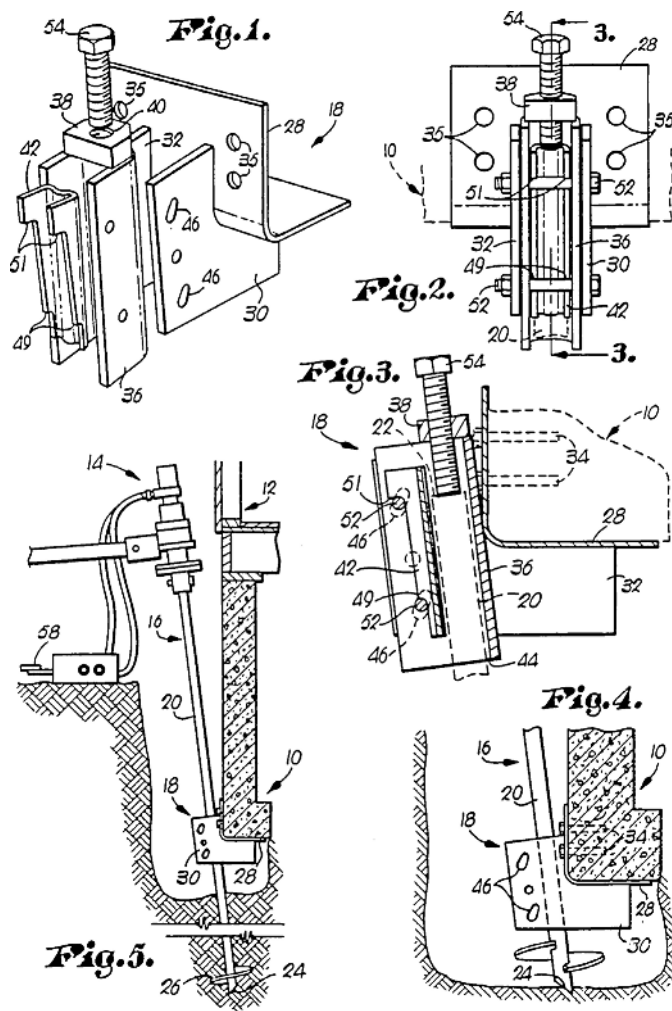
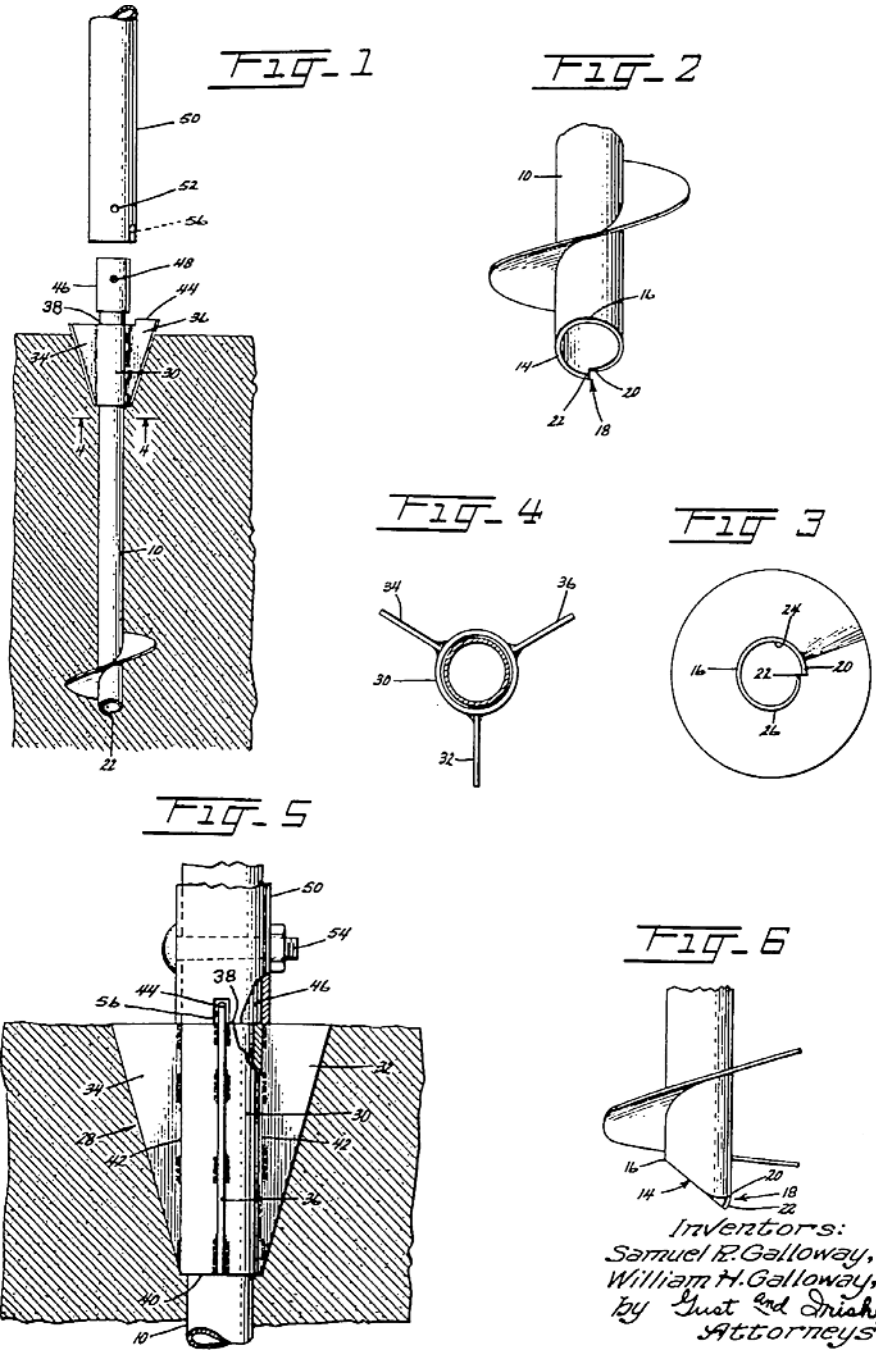

Figure 1.13 Hamilton foundation underpinning method

Many methods of enhancing the lateral stability of a slender helical pile shaft in soil have been patented through the years. Some of the earlier known methods were patented for helical piles used for fence posts. In 1898, Oliver patented a screw-type fence post with a shallow X-shaped lateral stabilizer where the pile meets the ground surface. A year later, Alter patented a screw-type fence post with large-diameter, shallow, cylindrical, lateral stabilizer also near the ground surface. Another example of a lateral stabilizer used with piles similar in appearance to the modern helical pile is shown in Figure 1.14. In 1961, Galloway and Galloway patented this method of placing three triangular plates on a swivel located on the trailing end of a helical pile. The plates or fins are drawn into the ground by the bracket on the end of the helical



Inventors:
Samuel E. Galloway,
William H. Galloway,
by Gust Ed. Smith,
Attorneys.

Figure 1.14 Galloway lateral stability device

pile as it advances into the ground. The helical pile with lateral stability enhancer can be coupled directly to a post or other structure.

The Galloway patent was followed in 1989 with the slightly different variation shown in Figure 1.15. In this variation, trapezoidal plates are attached to a square tubular sleeve slipped over the central shaft of a helical pile. The stabilizer sleeve is connected to a pile bracket using an adjustable threaded bar. Any number of structures

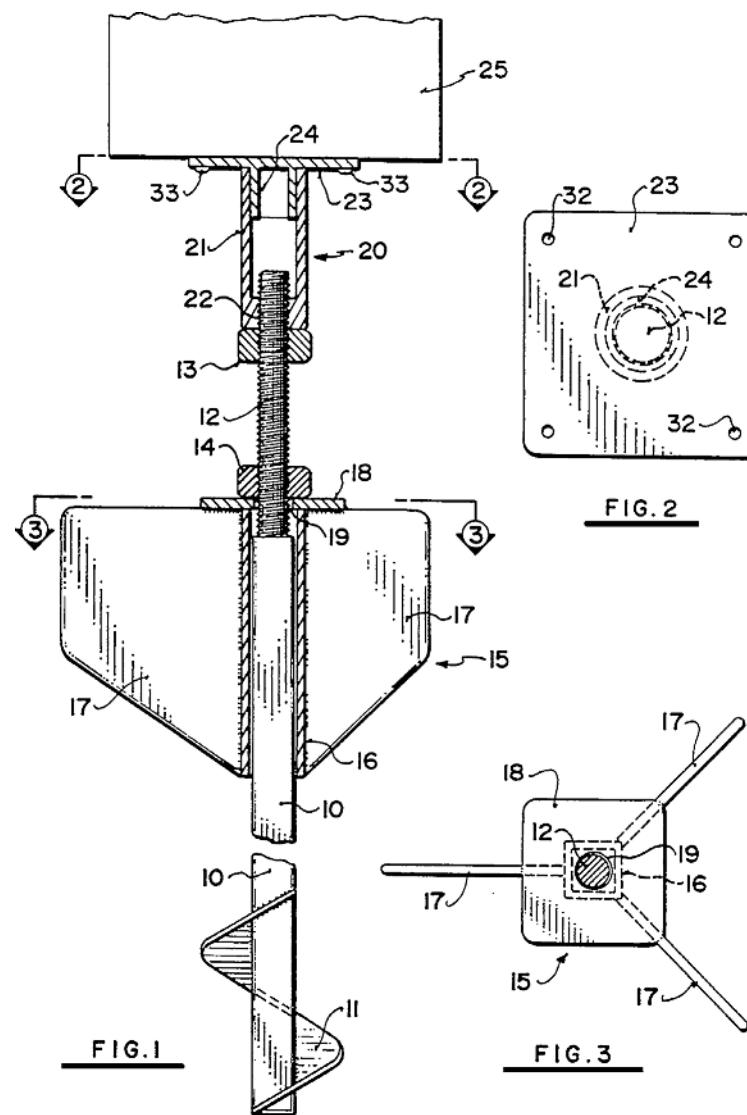

Figure 1.15 McFeetors lateral stability device

could be supported on the thread bar connection. Those familiar with the practice can see that there are many other approaches that could be taken to enhance lateral stability of slender shaft helical piles as are discussed later in this text.

Of course, another way to enhance the lateral resistance of a helical pile is to make the shaft larger. Many helical pile manufacturers currently produce relatively short, large diameter, helical lightpole bases. These products generally consist of a cylindrical or tapered polygonal shaft with helical bearing plate located at the bottom. The helical bearing plate is affixed to a short pilot point for centralizing the base. The top of the pile is fixed to a base plate with bolt hole pattern. Soil is forced aside most lightpole bases so that the central shaft remains empty during installation. In this way, an electrical conduit can be fed through the hollow center of the pile.

1.5 PERIODS OF USE

Much can be gleaned about the history of helical piles from studying the many patents filed through time. A plot of the number of U.S. patents filed regarding helical piles is shown in Figure 1.16. These patents can be grouped generally into four categories, or historical eras. As discussed in Section 1.2, the first uses of helical piles were for ship moorings, lighthouses, and other marine structures. The period from the invention of the screw pile to 1875, when these uses were most common, can generally be termed the “Marine Era.” Very few of the earliest patents from this era could be found. Patent 30,175 from 1860 and patents 101,379 and 108,814 from 1870 refer to improvements in prior art, which indicates earlier patents could exist.

A majority of the early patents in Appendix B, beginning with Mudgett in 1878 and ending with Mullet in 1931, involve fence post applications. Known developments in irrigation and plant/soil science during the same general time frame combined with the series of fencing related helical pile patents are reasons for naming this period the “Agricultural Era.”

The next group of patents, beginning in about 1920 and spanning into the 1980s, primarily regard guy anchors, tower legs, utility enclosures, and pipelines. This period can be termed the “Utility Era.” Historically, this period of time also corresponds to a number of significant infrastructure projects in the United States including many large dams, the interstate highway system, power plants, aqueducts, and great cross-continental electrical transmission projects.

The last group of patents, issued from roughly 1985 until the present, generally concern many types of buildings and other construction applications. Several patents relate to mobile homes, retaining walls, underpinning, sound walls, and special types of helical piles for foundations. This era can be termed the “Construction Era.” The Construction Era spans the residential housing boom in the United States.

The number of patents and proprietary systems on the market today should not dissuade the engineer, architect, and contractor from using helical piles. Rather, one should conclude from the vast history of U.S. patents that the helical pile and its many variations and applications, with a few exceptions, are public domain. The helical

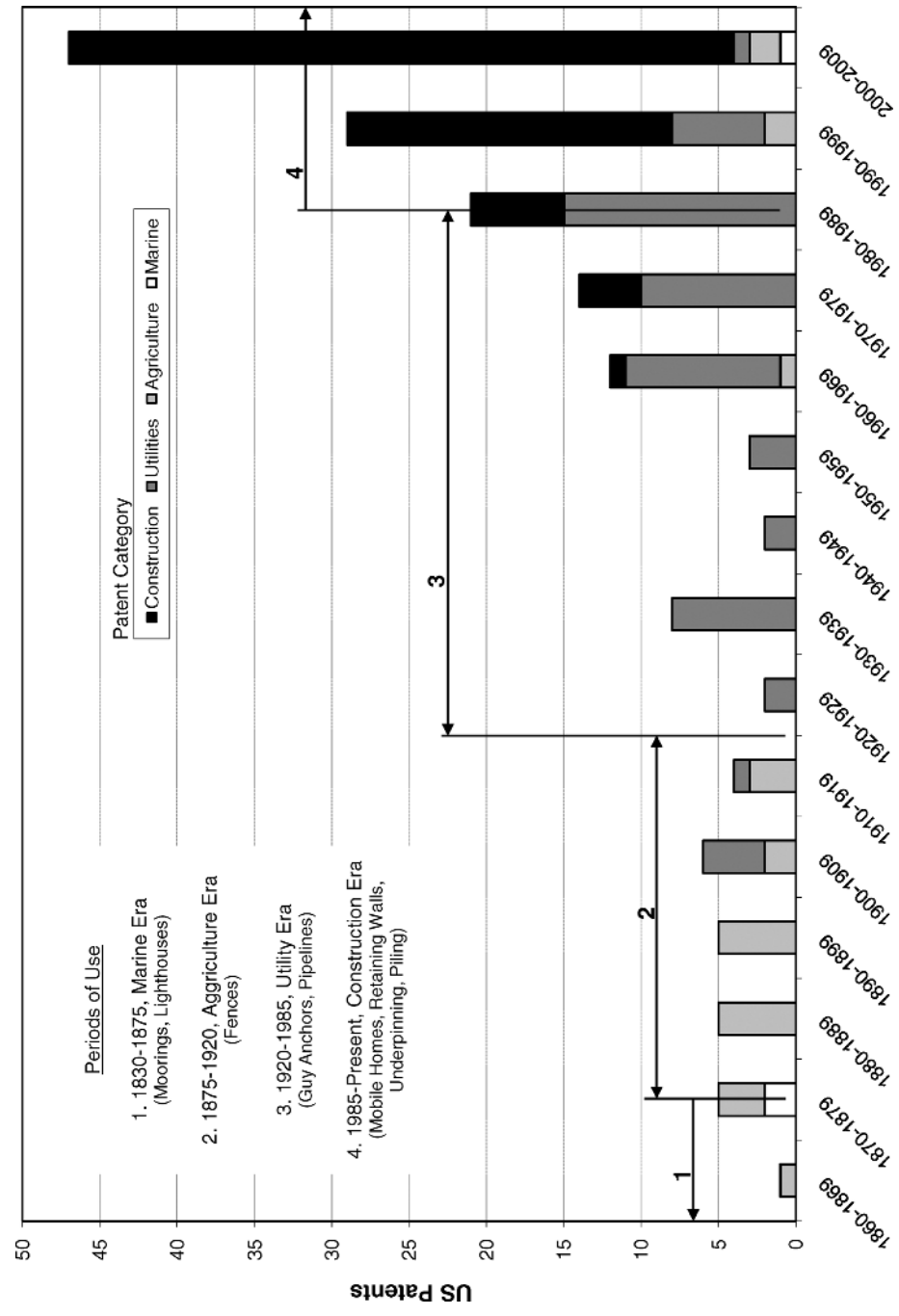

Figure 1.16 U.S. helical pile patents

pile can be used widely and diversely without fear of infringement on older patents. Newer innovations in helical piling also should be looked at with enthusiasm as these technological advancements can be drawn on when specific situations merit.

1.6 MODERN APPLICATIONS

Helical piles have many modern applications. In the electrical utility market, helical piles are used as guy wire anchors and foundations for transmission towers. For example, Figure 1.17 shows three square-shaft helical anchors embedded into the ground at a batter angle and attached to five high-tension guy wires. An example transmission tower foundation is shown in Figure 1.18. The tower in this image is founded on a cast-in-place concrete pile cap over several helical piles. A single helical pile can support design tensile loads typically on the order of 25 tons [222 kN]. An equivalent mass of concrete used in ballast for a transmission tower or guy wire would measure 8 feet [5.5 m] square \times 5 feet [1.5 m] thick. Using helical piles and anchors can reduce the amount of concrete required and result in cost savings especially in remote sites.

In residential construction, helical piles are used for new foundations, additions, decks, and gazebos in addition to repair of existing foundations. Helical piles are being installed for an addition to single-story mountain home in Figure 1.19. Helical piles were selected as the foundation for the addition in this image due to the remoteness of the site, uncontrolled fill on the slope, difficult access, and economics. Small and maneuverable installation equipment and low mobilization cost make helical piles ideal for sites with limited access, such as narrow lots and backyards. An article in the *Journal of Light Construction* claimed that these factors combined with the speed of installation make helical piles more economical than footing-type foundations for residential additions (Soth and Sailer, 2004).

A residential deck supported on helical piles is shown in Figure 1.20. The tops of the helical piles can be seen extending from the ground surface. The helical piles

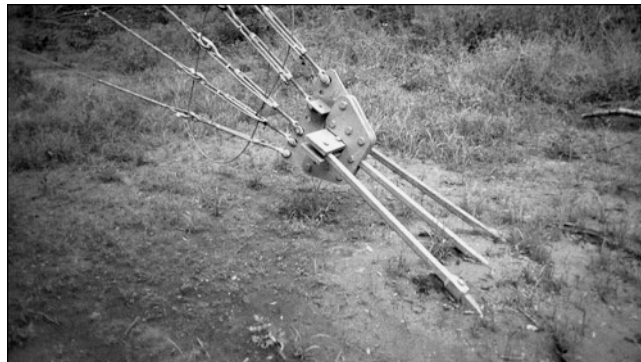

Figure 1.17 Utility guy wire anchors (Courtesy of Hubbell, Inc.)

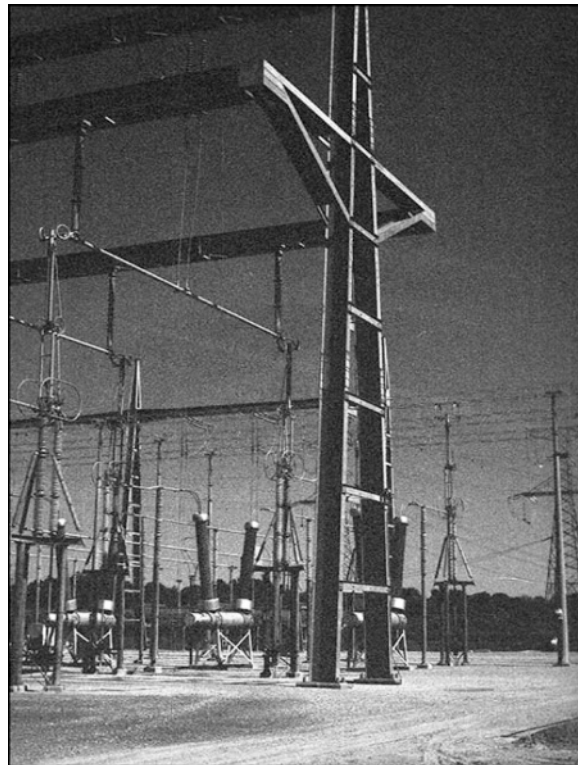

Figure 1.18 Utility tower foundations (Courtesy of Hubbell, Inc.)

are attached to wooden posts supporting the deck by a simple U-shaped bracket. The helical piles under the deck extend only 6 feet into the ground. Helical piles were used for this deck in northern Minnesota due to the depth of frost and pervasiveness of frost heave in this area. Uniform-diameter concrete piers that bottom below frost are often heaved out of the ground by successive freeze-thaw cycling. One of the unique features of the helical pile is its resistance to frost heave and expansive soils. The slender central shaft limits the upward stresses due to soil heave, while the helical bearing plates resist uplift. Entire subdivisions with hundreds of homes and decks have been founded on helical piles in areas of frost-susceptible or expansive soils.

There are almost unlimited possibilities with helical piles in commercial construction. The lightweight and low impact of installation equipment has made helical piles an attractive alternative in environmentally sensitive wetland areas. Many miles of nature walks have been supported on helical piles. An example nature walk is shown in Figure 1.21. Every 8 feet of this nature walk is supported on a cross member spanning between two helical piles embedded deep in the soft wetland soils. Nature walks can be constructed using helical pile installation equipment supported on completed portions of the walkway so that the equipment does not disturb sensitive natural areas.



Figure 1.19 Residential addition

Some nature walks are installed when the ground is frozen during the winter season to minimize the impact of installation equipment.

The ability to install helical piles without vibration in low-headroom areas within existing buildings has resulted in their use inside many commercial buildings where new loads are planned. The photograph in Figure 1.22 shows a stadium in South Carolina where helical piles were used to support the loads of a new weightlifting and locker room addition. Helical piles were installed to refusal on bedrock at depths of 30 to 40 feet [9 to 12 m]. Project specifications called for vertical design loads of 25 tons [222 kN] at each pile location and a maximum deflection of 1/2 inch [13 mm]. Two load tests were performed on the helical piles used for the stadium project, and the measured loads and deflections met project specifications.

Another example of how helical piles have been used inside existing buildings is to support mezzanines or additional floors. Given the many advantages of helical piles including speed and ease of installation, construction of foundations inside retail or warehouse buildings can be done during off hours without disruption for the proprietor. A photograph of a new mezzanine foundation under construction is shown in



Figure 1.20 Deck and gazebo foundations (Courtesy of Magnum Piering, Inc.)

Figure 1.23. As can be seen in the figure, the work area can be sectioned off from the other areas of the building with a dust and visual barrier. Compact, low-noise equipment can be used to conduct the work.

Helical piles have been used to support staircase and elevator additions for satisfying new commercial building egress requirements for a change of use. Helical piles also have been used to support heavy manufacturing equipment within commercial buildings. The slender helical pile shaft has a high dampening ratio for resisting machine vibrations.

Helical piles can be combined in a group to carry larger loads of commercial construction. The International Building Code, Chapter 18, states that the tops of all types of piles need to be laterally braced. A common way to accomplish this is to use a minimum of three piles in a group to support column loads. Three helical piles can support design loads on the order of 75 to 600 tons [670 to 2,5,340 kN]. In this way, helical piles have been used in a variety of low- to high-rise commercial construction projects.

Another feature that makes helical piles attractive is the ability to install in almost any weather condition. Figure 1.24 shows installation of helical piles being conducted in the rain for a Skyline Chili restaurant. This project was originally designed for driven wood piling with a design capacity of 25 tons [222 kN] per pile. A contractor bid the project using helical piles as an alternative and was found to be more economical. One 25-ton [222 kN] helical pile was substituted at each driven pile location. It turned



Figure 1.21 Nature walk construction (Courtesy of Magnum Piering, Inc.)

out that adverse weather conditions would have delayed pile driving by several weeks. Thirty-five helical piles were installed in two days during the adverse weather and the project continued on schedule.

Another application of helical piles is for underground structures and excavation shoring. The project depicted in Figure 1.25 shows an excavation and pile foundation for an underground MRI research facility at Ohio State University. Helical anchors and shotcrete were used to support the staged excavation on this project, while closely spaced helical piles were used to construct the foundation. The MRI facility has 5-foot- [1.5-m-] thick reinforced concrete walls and ceiling for radiation shielding. Each of the piles is required to support a design load of 25 tons [222 kN]. The excavation was made inside an existing university building. Groundwater and soft soils were encountered at the base of the excavation. Lightweight, tracked machinery was used to install the helical piles. (Perko, 2005)



Figure 1.22 Stadium locker room addition

Another application of helical anchors and shotcrete for excavation shoring is shown in Figure 1.26. This shoring system was constructed for the basement of a retail building. The excavation was made in several stages. Reinforcing steel and manufactured drain boards were placed over the excavated soil after helical anchor installation. Several layers of shotcrete were applied over the reinforcing steel until a smooth uniform broom finish was achieved.

Helical anchors are often used as tie-backs in a variety of other shoring systems, including sheetpiling and soldier piling. They also can be used as soil nails by spacing helical bearing plates along the entire length of the shaft. Helical anchors were used to support a majority of the earth-retaining walls in Ford Field in Detroit, Michigan. Helical soil nails have been used coast to coast in the United States. With small, lightweight equipment and the short bond length of helical soil nails and helical tie-backs, many have been able to deal with site access restrictions and limitations of rights-of-way or property boundaries. A photograph of helical anchors being installed to tie back a soldier beam and lagging system for a medical building is shown in Figure 1.27. The final excavation was approximately 18 feet [5.5 m] deep. Two horizontal walers were held in place by virtue of helical anchors spaced at roughly 5 to 6 feet [1.5 to 2 m] on-center.



Figure 1.23 New mezzanine foundation (Courtesy of Earth Contact Products, Inc.)

1.7 ENVIRONMENTAL SUSTAINABILITY

Helical pile foundations are an environmentally conscientious and sustainable construction practice. The construction of a helical pile foundation consumes less raw material and requires fewer truck trips compared to other types of deep foundations. Substitution of helical piles for other deep foundations almost always reduces the carbon footprint of a foundation. Helical piles also can reduce disturbance in sensitive natural areas.

The unique configuration of helical piles consisting of large bearing surfaces and slender shafts is an efficient use of raw materials. The construction of helical piles requires on the order of 65 percent less raw materials by weight to construct compared to driven steel piles and 95 percent less raw material by weight compared to drilled shafts or augercast piles.

Helical pile foundations require fewer truck trips to and from a construction site. Installation of a helical foundation system requires the piles be shipped from the supplier to the site and mobilization of the installation machine. Construction of a drilled shaft foundation requires shipments of reinforcing steel and concrete as well as mobilization of a drill rig and often a concrete pump truck. As can be seen in Table 1.2, it takes fewer truck trips, to and from a construction site, to install a helical pile



Figure 1.24 Adverse weather installation (Courtesy of Magnum Piering, Inc.)

foundation system compared to other deep foundation systems. Fewer truck trips mean less traffic, less pollution, and less wear-and-tear on roads, streets, and highways.

Helical piles reduce the overall carbon footprint of a project in many ways. Even though helical piles are typically shipped long distances (e.g., from national supplier to construction site), the fact that helical pile foundations require less raw material by weight and fewer truck trips means that overall energy consumption for material transportation often can be much less. For a recent project, it was determined that shipping approximately 350 helical piles from Cincinnati, Ohio, to Denver, Colorado, consumed on the order of 40 percent less fuel than would be required to transport concrete and reinforcing steel from local suppliers to the site for the construction of a drilled shaft foundation with equivalent capacity and performance (Perko, 2008a). The omission of concrete for the foundation piles also reduced pollution because the production of cement is one of the leading producers of carbon emissions. On many occasions, helical piles can be installed with smaller equipment with better fuel



Figure 1.25 Helical pile foundation for underground MRI facility (Courtesy of Magnum Piering, Inc.)



Figure 1.26 Shotcrete and helical anchor shoring system



Figure 1.27 Soldier beam and lagging system with helical tie-backs (Courtesy of Earth Contact Products, Inc.)

Table 1.2 Required Truck Trips

Foundation Option	Number of Trips to/from Site	Trip Description
50 helical piles	1	truck & trailer (installation machine)
	2	flatbed tractor-trailers (helical piles)
	3	
50 drilled shafts	14	concrete trucks
	1	pump truck
	1	flatbed tractor trailer (reinforcing steel)
	1	drill rig
	17	
50 driven H-piles	2	crane delivery & pickup
	4	flatbed tractor trailers (H-Piles)
	1	pile-driving rig
	7	

economy in a shorter time period than other deep foundations. Fuel savings and less air pollution during installation of helical piles reduce the carbon footprint still further.

Helical piles make excellent low-impact foundations for projects that are located in environmentally sensitive areas, such as wetlands, prairies, or historical sites. Lightweight installation equipment minimizes disturbance, making less impact on fragile ecosystems. Structures can be constructed over marshland by keeping the machine on the constructed sections and reaching out to install the helical piles. Alternately, construction can be done during the winter season by installing helical piles from frozen ground. Overall, helical piles may be one of the most environmentally friendly deep foundation systems.

