

PART

I

---

# Getting Started

COPYRIGHTED MATERIAL



# CHAPTER 1

---

## The Mental Transition to Building Information Modeling

---

### **BIM—A WHOLE-BUILDING APPROACH TO DESIGN**

Building information modeling changes the way architects, engineers, and contractors work today. It promotes collaboration among all members of a project team, and opens the door for additional members to add relevant information to the design before considerable development has occurred. In traditional two-dimensional drawing, the design and documentation are disjointed in that there is no real relationship between a window and a wall, a wall and a roof, or the roof and the outdoors. BIM allows the design to be looked at as a whole, rather than as individual components that show up on some schedule that was manually created.

The design process no longer consists of lines that represent and enclose spaces and symbols that represent building components. Rather than drawing a series of lines that represent the location of a wall, we can draw the wall itself as a single unit, carrying all of the components and layers associated with it. Floors, ceilings, and roofs are drawn as the areas in which they exist, with the ability to add a specific slope, thickness, and type, as well as identify every

component of the assembly. Rather than symbols being used to represent building components in a project, such as windows, doors, fixtures, and fittings, a graphic representation of the component is placed at its appropriate location. These components may be trained to understand how they are to be placed within the project, what they are, and how they relate to adjacent elements in the project.

Openings such as windows and doors are elements placed in a wall to allow the passage of light, traffic, and, in some cases, air. As a window or door is placed into a project, it is trained to remove a specific volume from the wall based on its determined rough opening. Since the window or door is typically not as thick as the wall itself, it allows the user to look at or through the opening from different three-dimensional views, providing a realistic perspective of the building. As components are placed into a model, and volume is removed from the host component, in this case a wall, the information is stored within the software so it may be retrieved later. The type and counts of each component are noted, as well as their dimensions, areas, and locations. Above and beyond visualization and conceptualization of a project, this type of information may be leveraged for square foot cost estimation early in the project, and more accurate quantity takeoffs during bidding. Figure 1.1 depicts the relationships between two-dimensional linework and three-dimensional modeling.

During the early stages of a project, the most important elements used in a project are the walls, floors, roofs, and openings. These elements determine

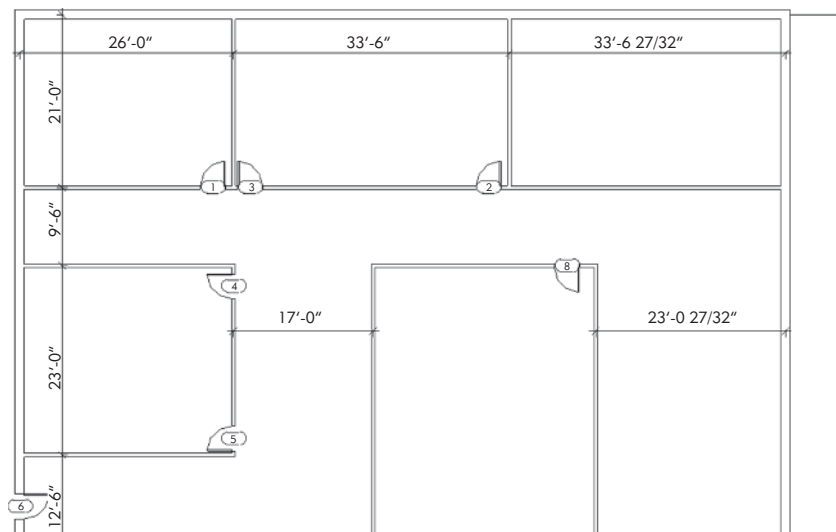

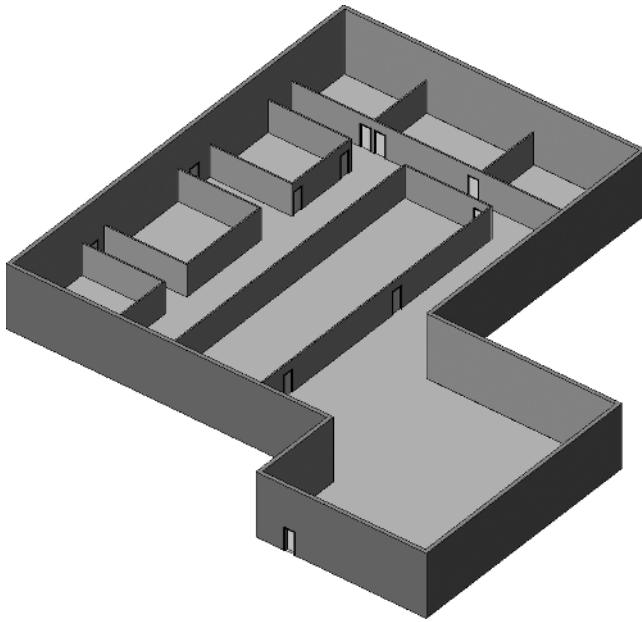

**FIGURE 1.1** 2D linework and 3D modeling

how spaces are enclosed, how those spaces are accessed, where natural light and visibility exists, and why their locations may be beneficial or detrimental. Before the addition of a considerable number of components that complete the overall design, these core elements are added to the model for analysis of the preliminary or schematic design. In many cases, interior walls may not even be created at this point, as locations of HVAC (heating, ventilating, and air conditioning) components, plumbing, and electrical wiring often take precedence over the location of interior partitions. The design process of every project is different, as every project has a different intended purpose, a different set of design criteria, and a different construction style. Building information modeling gives architects and engineers the flexibility to design in the same way they usually do, but to have a more robust set of tools to work with, a more intelligent design platform, and the ability to analyze the design on the fly.

The most notable difference between computer-aided design (CAD) and building information modeling is the aspect of working in three dimensions. As we transition to working in three dimensions, the brain must be rewired to think in three dimensions. For some this is an uphill climb, while for others, it is second nature. Ultimately, the finished plans submitted to the contractor for construction are two-dimensional, and on paper; however, during the design process the model created may be viewed at any angle, from any

location. This allows owners and designers the ability to see exactly what is being built prior to construction, as well as to determine spatial relationships and make determinations of how much area is necessary for a given room or space. Three-dimensional conceptualizations and high-resolution, photorealistic renderings become a function of the design model. These high-definition deliverables allow the industry to digitally prototype a construction project, affirming design intent and visually confirming that design expectations are being met.

As noted, a model created can be viewed at any angle necessary. All of these views are a function of the model as it is being created, and automatically update themselves based on what happens in the design. If we place a window in plan view, it will show up in its corresponding location when viewed in an elevation view. If we place a lighting fixture from within a 3D view, it shows up in its appropriate location when viewed in plan view. This eliminates the need to manually create an entire series of views as with traditional CAD software. Views may also be created that consider only specific components, allowing quick creation of trade-specific drawing sheets, which may apply to structural, electrical, plumbing, or other work to be performed on the project. This drastically reduces the amount of time necessary to create drawing sheets, maximizing the amount of time available for the architect to think through the actual design. The expertise of an architect lies in his ability to create beauty and maximize the aesthetic. Putting pen to paper so to speak, only documents and visualizes the architect's ideas so that others may construct what he has created, so it seems only natural to minimize the amount of effort necessary to convey the design.

Once the modeling of the project is complete, two-dimensional detailing occurs in order to create exact depictions of transitions, terminations, penetrations, and junctions throughout the project. Where a roof meets a wall or a wall meets the floor, there are countless ways in which construction could occur, based on project circumstances that are not known by the software. Since the software is not intuitive enough to understand different design criteria and construction methods, we rely on two-dimensional detailing to convey this information. Typically, either this line work is drawn in manually or additional detail objects are dropped in for repetitive types of detailing. The section view of dimensional lumber or a concrete block is the same throughout the project, so rather than redrawing the line work every time, a two-dimensional detail object may be dropped in to represent the cut view.

Another component of two-dimensional views is the annotations or call-outs that are used to point to various materials and components shown. With building information modeling, information about components and materials

can be generated automatically by adding specifically designed annotations to call out that material or component.

While there is nothing wrong with the way the design, construction, and procurement teams work today, building information modeling forces the industry to rethink how projects are delivered. In a traditional project delivery method, there is little collaboration among the parties. *The owner works with the architect. The owner works with the contractor. The architect works with the contractor. The contractor works with the subcontractor. The project is designed and built.* Linguistically, the last four sentences are disjointed, and while there is nothing wrong with each sentence independently, when read together, they do not flow. The same is true of any type of project; the more collaboration that occurs, the better the flow, and the faster it happens. In a collaborative environment, we may read something like this: *The owner, architect, contractor, and subcontractors collaborate, and the project is designed and built.* These are the fundamental concepts of Integrated Project Delivery or IPD.



**FIGURE 1.2**  
The collaborative approach to design and construction

## CAD VS. BIM

Building information modeling offers many advancements over traditional two-dimensional and even three-dimensional computer-aided design technology. The original concept of CAD was to be able to draw simple lines quickly and easily without having to rethink and erase large parts of a drawing on paper. This was a tremendous advancement over hand drawing and considerably cuts down the amount of time necessary to document a design. As CAD technology grew, it allowed us to separate different line types and categorize the different lines into various layers based on what was necessary in given views, and ultimately entered the world of three-dimensional design. When architecture moved from designing using two-dimensional lines to using three-dimensional solids, the game had changed forever; enter building information modeling.

The technology shift from CAD to BIM gave the design community the ability to look at not just what an element within the project looks like, but what it is. A wall that was previously represented as a series of lines in different views is now a component in and of itself. It carries information about each component that makes up the assembly, how the assembly performs as a whole, and even what the assembly is in terms of adjacent components. The wall intuitively determines how it connects to other components, and how other components connect to it. When placing a window within a wall, the wall understands that it must create an opening, and the window understands that it can only be placed in a vertical application such as a wall.

Building information modeling opened the door for assigning attributes to each component created within the model. Whether it is a dimension, a material, or a nongraphical piece of information regarding the performance of the component, the information may be contained within the component for access, manipulation, and retrieval. As simple as it may sound, this advancement created one of the largest cost benefits that the design and construction communities have ever experienced. This parametric technology allows us to reuse components and line work over and over, rather than needing to redraw them on each project. Instead of having to draw a different door for each size, material, or style, attributes are assigned to the various dimensions, materials, and styles. These attributes can be assigned values, which can allow a single door component to represent a countless number of combinations of size, material, and style to suit a project.

Outside of graphics, building information modeling has advanced architecture's ability to manage information effectively. Each component within a project has the ability to carry as much or as little information as is necessary to suit the needs of the owner, design team, specifier, or contractor. In most



cases little or no information above and beyond dimensions and basic graphic information is added to these components, as the information is generally related to a specific manufacturer's product. Architects are not in the business of creating product information for manufacturers, so the responsibility for providing models that contain exact information about a product lies in the hands of the manufacturer. When specific attributes regarding the performance, usage, installation, and lifecycle of the product are added, architects may leverage this information in several different ways: a model may be queried to extract the information for creating construction documents and the project manual; a series of schedules can be created to represent each and every component of the model; contractors can sort through the model to find the required performance for the work they are responsible for. The software itself has the potential to leverage information that is placed in the model for criteria analysis. Attributes related to energy consumption may be analyzed, as well as the structural performance of the individual component in the building as a whole, thermal performance, and code compliance, and a host of other studies may be performed. Third-party software plug-ins are allowing better and more accurate analysis of models as the technology advances, but still rely on the basic information associated with individual components. The more information we add to the components and the project as a whole, the more analysis we may perform as time moves forward.

During construction it is not uncommon to find instances where two elements interfere or "clash" with each other because the design did not take into consideration exact locations. When a design is created using two-dimensional means, the various views used to represent the project are disjointed, so when dealing with components, such as ductwork and pipe, it is difficult to accurately depict their elevation and slope such that they do not interfere with structural members. This "clash detection" technology, shown in Figure 1-3, allows more accurate design prior to construction, minimizing and in some cases eliminating costly change orders that occur in the field.

Building information modeling is by no means the panacea for all that ails the architecture and construction professions and is not without its downsides and pitfalls. As with all new technologies, there is a learning curve associated with understanding new methods for performing tasks and becoming skilled in using different software. Seasoned professionals who have been using computer-aided design technology for most or all of their career may find themselves resistant to this change until they understand all of the benefits associated with switching. Just as architects who drew by hand were resistant to designing with CAD, many architects drawing with CAD

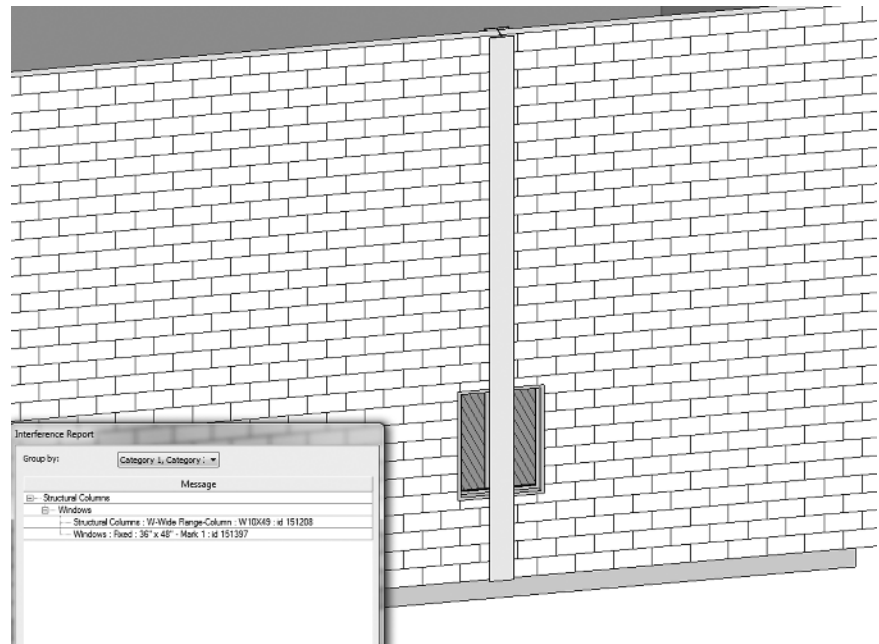

**FIGURE 1.3**  
Clash detection  
analysis

are resistant to BIM. Outside forces such as government agencies and code bodies are causing some professionals to switch by requiring the use of BIM on specific projects or in certain locations. Over the past couple of years, building information modeling has experienced exponential growth. Prior to that, there was a chicken and egg scenario where architects were hesitant to switch until more manufacturers made their products available, and manufacturers were hesitant to make their models available until more architects were using it. A relatively slow growth pattern ensued until critical mass was reached, where enough architects and enough manufacturers were involved to make it a viable mainstream option. Since then, manufacturers have seen the benefits of making components available, and architects have found themselves saving considerable amounts of time between the new technology and the abundance of content available for modeling.

---

## CAD + SPECS = BIM

To put it simply, CAD + specifications = BIM. Without the attributed data associated with components, we might as well be using traditional CAD software. By definition, CAD is computer-aided design, regardless of whether it is performed in two dimensions or three dimensions. BIM is building

information modeling, with emphasis on the “I”, which is what differentiates the two technologies. CAD can be defined as both computer-aided design and computer-aided drafting, but both cases emphasize the “computer-aided” aspect of the proposition. BIM can be defined as both building information modeling and building information management, and, similarly, the “building information” aspect is emphasized.

The real value proposition of building information modeling lies in the ability to analyze data. Any cheap CAD software can provide conceptualizations and visualizations of a project and work in multiple views based on a singular model. This is nothing new. Better CAD software provides robust professional tools that are more intuitive and are based on the needs of the design team. Neither of these technologies has the ability to understand the difference between a floor and a roof, as they do not have the embedded information that defines the differences between the two.

For all practical intents and purposes, CAD carries only graphic information. There are rudimentary ways of organizing the different line types to create a minor definition for them, but CAD does not have the ability to understand their relationships to other components, only to their place in space. If we take three-dimensional CAD technology and merge it with the information found in a project manual, we have the ability to assign as well as limit the associations we create. We can create a series of paints and coatings, and limit them based on the VOC (volatile organic compound) requirements of the project. We can create a series of walls, and limit them based on their thermal performance. This allows project templates to be created that may be reused over and over and that carry specific requirements. Schools, for instance, may not be allowed to use products that contain VOCs. A template may be created that carries only products that apply, or that is designed specifically to show the VOC amounts for all components in the project. Other components may be required to attain specific performance values and the design team may have preferred manufacturers for certain component types. Embedding this type of information into a model allows us to “digitally prototype” a project well before construction, analyze it for its merits and miscalculations, and correct or improve upon design elements before the first shovel hits the dirt.

The graphics of BIM outline what a component looks like. The specifications carry information regarding what a product is and why it was selected. There are justified reasons for using certain products in certain applications. Whether it is sizing an HVAC system based on the size of the project or using specific types of metals for roof flashings based on its proximity to the ocean, there is intent behind each decision the architect, engineer,

specifier, or contractor makes. While we would like to think that all of these parties are collaborating on every project they perform together, this is not the case. Information can be disjointed, so to assist in information exchange, creating a single point of reference from which information may be sourced allows everybody to have the correct facts without actually being in the same office or even working on the project at the same time. The building information model is the logical point of reference, as it has the ability to carry both graphic and nongraphic information regarding every aspect of the project, from general requirements all the way through facility management. The earlier this information is embedded into the project, the more accurate and useful it may be throughout the project lifecycle.

In building projects today, the design begins with the owner and the architect. An owner may hire an architect to design a building based on his needs and requirements. Early in the project lifecycle, very few decisions are made regarding specific components and exact details. Using building information modeling to create a preliminary design of the building based on its walls, floors, roofs, and openings gives both the architect and owner a rough idea of the project scope. Generally, no information is contained within the components used for this schematic design; but what if there were? If we look at a project as linear rather than a series of steps or phases, it makes more sense to embed attributes into these components but omit values until such a time as decisions are made. This streamlines the design process by minimizing the amount of component swapping that is necessary throughout design development. Rather than create five versions of the same component to represent five different levels of detail or project phases, it is far more effective to create a single component that can evolve based on the amount of information known about it. A window, for instance, might morph from opening, to window, to aluminum window, to aluminum casement window, to a specific manufacturer's product as decisions are made regarding that specific component. This allows information to be added in a rolling fashion rather than during specific phases, or even all at once.

Component selection can be tricky and is often based on the knowledge of other related products. Specific types of roof insulation may be necessary based on the type of roof membrane used and how it is attached based on the type of substrate beneath it. The type of roof membrane used may be dependent on the location of the project and the needs of the owner. We don't have to know all of these pieces of information to make decisions, but if there are hard-line project requirements that can be built into the model early on, product decisions that are based on those requirements may be made to narrow the field to only products that are suitable.

When researching products for their suitability in certain circumstances, architects and specifiers often must search high and low to find information that helps them make decisions. By embedding additional resource information into the components in the form of Web links, the design team has a powerful tool to find the information necessary to determine and affirm whether a product is suitable for their design. Early in a project, the requirements for the glazing in a building may be unclear. Embedding links to more information from either specific manufacturers or trade industry organizations can assist in appropriate specification with the least amount of effort. Similar information may be embedded regarding the installation procedures, procurement, code restrictions, and maintenance requirements of the product.

---

## CONCLUSION

As we transition from computer-aided design to building information modeling, we need to understand that it is a long-term transition that benefits not only the design team but the world as a whole. BIM allows us to digitally prototype projects the same way the automotive and aerospace industries have done for years. If we look at the improvements seen by the automotive industry from leveraging digital prototyping, we will see that today we have much safer cars that are designed to last much longer, perform better, and get better fuel economy. If we translate that to building design and construction, it will ultimately equate to better structural integrity of buildings capable of withstanding seismic activity, weather events, and even terrorist attacks.

By analyzing information in the model, we can create buildings that use less electricity, have more efficient and effective heating and cooling systems, and protect their occupants from harm. Whether we want to improve indoor air quality, minimize the amount of artificial light in a building, create efficient traffic patterns throughout a building, or plan for means of egress in the event of an emergency, building information modeling is a powerful analytical tool. It takes what we know of design and construction and hands it to a computer that returns results that we may analyze and use in making decisions.

To err is human, but to truly botch a task requires a computer. It is important to understand that BIM is little more than a better tool for the job. It does not replace the knowledge and understanding of a seasoned specifier who is expert in selecting products, nor does it replace an architect capable of designing magnificent structures. Engineers are still required to design structural, HVAC, plumbing, and electrical systems. Building information modeling takes much of the legwork out of the design by creating tools that automate mundane

tasks. Software does not understand the physics of force, electricity, hydrology, or strength of materials, but can only manipulate the information supplied by competent individuals who are expert in the design and implementation of a given product.

BIM should not be thought of as a decision engine or “configurator” that will select the right product for project, or a tool that will automatically generate our specifications based on the products. These are noble concepts, and one day artificial intelligence may allow building information modeling to learn from its mistakes and assist in product selection. I would caution us to be careful what we wish for, though, as that type of technology would put the entire design team on notice.