

CHAPTER 1

OVERVIEW, GOALS AND STRATEGY

Bodily exercise, when compulsory, does no harm to the body; but knowledge that is acquired under compulsion obtains no hold on the mind.

—Plato

1.1 GOOD MORNING

I don't know whether now, the first time you open this book, it is morning, afternoon, or, perhaps, night, but for sure it is the morning of a long day, or, better, it is the beginning of an adventure. After a preparation phase, this journey will enable you to meet electronic systems, will let you get inside intriguing architectures, will help you in identifying basic functions, will show you how electronic blocks realize them, and will give you the capability to examine these blocks made by transistors and interconnections. You will also learn how to design and not just understand circuits, by using transistors and other elements to obtain electronic processing. Further, you will know about memories used for storing data and you will become familiar with other auxiliary functions such as the generation of supply voltages or the control of accurate clock signals. This adventure trip will be challenging, with difficult passages and, probably, here and there with too much math, but at the end you will, hopefully, gain a solid knowledge of electronics, the science that more than many others has favored progress in recent decades and is pervading every moment of our lives.

If you are young, but even if you are not as old as I am . . . (well, don't exaggerate: I have white hair, I know, but I am still young, I suppose, since I look in good shape). If you are young, I was saying, you have surely encountered electronics since the first minute of your life. Electronic apparatus was probably used when you were born, and even before that, when somebody was monitoring your prenatal health. Then you enjoyed electronics-based toys, and you have used various electronic devices and gadgets, growing in complexity with you, many times a day, either for pleasure or for professional needs, ever since. Certainly you use electronics massively and continuously, unless you are shipwrecked on a faraway island with just a mechanical clock and no satellite phone, with the batteries of your MP3, Personal Digital Assistant (PDA), tablet or portable computer gone, and no sophisticated radio or GPS.

Well, I suppose you have already realized that electronics pervades the life of everybody and aids every daily action, and also, I suppose, you assume that using electronics is not difficult; electronic devices are (and must be) user friendly. Indeed, instruction manuals are often useless, because everybody desires to use a new device just by employing common sense. People don't have the patience to read a few pages of a small multilingual booklet. Moreover, many presume that it is useless to know what is inside the device, what the theoretical basis governing the electronic system is and what its basic blocks and primary components are, and, below this, to know about the materials and their physical and chemical properties. In some sense, an ideal electronic apparatus is, from the customer's point of view, a black box: just a nicely designed object, intuitive to operate and capable of satisfying demanding requests and expectations.

What do you expect from a microelectronic system?

I suppose, like everybody else, you expect to be able to use the system by intuition without reading boring instruction manuals, to have an answer to your request for high performance, and to pay as little as possible.

Indeed, it is true that modern electronic equipment is user friendly, but, obviously, to design it, to understand its functions in detail, and, also, to comprehend the key features, it is necessary to have special expertise. This is the asset of many professionals in the electronics business: people who acquire knowledge up to a level that gives the degree of confidence they need so as to perform at their best in designing, marketing, promoting, or selling electronic circuits and systems.

Therefore, we (you and I) are facing the difficult task of transforming a user of friendly electronics or microelectronics into an expert in microelectronics. For that, it is necessary that you, future electronics professional, open (and this is the first obstacle), read, and understand a bulky book (albeit with figures) printed on old-fashioned paper. This is not easy, because anyone who uses a computer and the Web is accustomed to doing and knowing without feeling the need to read even a small instruction manual.

I have to admit that the method followed for decades in teaching scientific and technical topics is perceived as out of date by most modern people. I am sure you think that starting from fundamentals to construct the building of knowledge, step by step, is really boring! There are quicker methods, I assume you think. Indeed, following the traditional approach requires one to be very patient and not to expect immediate results as with modern electronic aids. Nevertheless, it is essential to be aware that fundamentals are important (or, better, vital). It is well known that a solid foundation is better than sand: a castle built on sand, without foundations, will certainly collapse. That is what old people usually say, but, again, studying basic concepts is tedious. So what can I do to persuade you that fundamentals are necessary?

Perhaps by narrating a tale that I spontaneously invented many years ago during a debate at a panel discussion. That tale is given here.

The man who owned 100 cars

A rich man was so rich that he owned 100 cars, one for every moment of his life, with three drivers per car available 24 hours a day. The drivers' job included unrolling a red carpet on the small paths from one car to the next and having every car available every moment of the day and night. One marvelous day the wife of the rich man gave birth to a beautiful child. This brought great happiness to the man, his wife and the 300 drivers of the 100 cars.

Two years later, as the second birthday of the lovely boy approached, it was time to decide on the birthday present and the rich man already had thought of a small car with golden wheels. He asked his wife: "*What do you think?*". The lady promptly replied: "*I would prefer a pair of shoes.*" "*What?*" cried the man, "*I have 100 cars and miles of red carpet! My son does not need to walk! Shoes are for the poor people that have to walk.*"



After the panel, when the discussion was over, a colleague of mine approached me, saying: "Excellent! You exactly got the point. Fundamentals are essential. You are right; having cars does not justify bare feet." He fully agreed with me, and certainly liked the way I described the need to know fundamentals even if powerful tools are available for helping designers.

The risk is that computer tools, embedding overwhelming design methods, favor the habit of trying and retrying until acceptable results are obtained. Therefore computer support often gives rise to results that appear very good without requiring the hard intellectual work that is supported and favored by a solid technical background.

Indeed, fundamentals are essential, but knowing everything is negative: it is necessary to settle at the right level. Saturating the mind by a flood of notions creates too many mindsets and, consequently, limits creativity. A discussion on creativity would take pages and pages, and I don't think this is the proper place to have it. However, remember that a bit of creativity (but not too much) is the basis for any successful technical job. Blending basic knowledge, creativity, quality, and execution must be the goal. This makes the difference between a respected (and well paid) electronic engineer and a pusher of keys.

Remember that anybody is able to push buttons, so becoming a key pusher does not add much to professional capability. Even a monkey can do that! So, the key point is: *where is the*

added value? What makes the difference? Obviously, for a successful future, it is necessary to acquire more than the capability of pushing buttons. For this, computer-aided tools should not be used for avoiding thought but for improving the effectiveness of the learning process. This is very important, and, actually, the goal of this book is to provide, with a mix of fundamentals and computer-aided support, the basis of that added value that distinguishes an expert.

Now, I think that is enough introduction, and after this long discussion (it may be a bit boring) I suppose that you, my dear reader, are anxious to see the next step. So, . . . let's organize the day. And, again, good morning.

1.2 PLANNING THE TRIP

When planning an adventurous trip, for safety and to ensure your future enjoyment it is recommended that you check a number of points. First, you have to define the trip in terms of a wish list; for example, you need to define whether you want to camp out at night, bunk in a rustic hut or stay in a five-star hotel. Also, you need to state whether you plan to stop in a small cafe and chat with local people or whether you desire to visit a museum. For this special adventurous trip, I suppose your wish list includes:

- the desire to become an expert on electronic systems, to know their basic properties, to be able to assess them and to recognize their limits;
- the wish to know more about the signals used and processed in electronic systems so as to understand whether a parameter value is good or bad and to learn how to generate test signals and use them for performance verification;
- the ability to read circuit diagrams so as to see, possibly at a glance, where the critical points are and to estimate expected performance;
- the desire to know about the basic blocks used in a system, to optimize the key performances by using computer simulation tools and to know how to interconnect those blocks so as to obtain given processing functions;
- the willingness to know in detail how transistors work and to learn the modern integrated technologies used to realize transistors and integrated circuits;
- curiosity about modeling transistors and the physical and chemical basic principles underlying their fabrication.

Well, I am not sure that all the above points are your goals, but, frankly, even a subset of them is a bit ambitious and will surely require significant efforts to achieve. But don't be discouraged. After the initial steps the path will be more and more smooth, and with the help of this book you will (hopefully) obtain good results.

After deciding on the type of trip (device oriented, integrated circuit oriented, system oriented, or another type), it is necessary to verify that you are in the proper shape to enjoy the experience. For this, there are a number of requisites that are essential. The most relevant are:

- a reasonable mathematical background with the ability to solve first- and second-order differential equations;

- knowledge of Kirchhoff's Laws, some knowledge of Laplace and Fourier transforms, and familiarity with writing mesh and nodal equations and solving such equations;
- good knowledge of the use of a computer, how to install programs and how to use the Web.

As a side note on the last point, after emphasizing that, obviously, you have to become familiar with simulation tools, I have a recommendation: do not blindly rely on numerical results. The description of a system is based on models that are always an approximation, and the numerical results are sometimes not accurate, or even credible. Therefore, use your brain first, and believe only results that conform to your personal intuition. However, your “computer brain” is not infallible, and computer simulations can help with understanding when mental reasoning possibly fails.

To do

Refine the wish list on the basis of your future activity (state what is the professional profile you would like to pursue). In preparation of this electronic trip, check and expand the list of prerequisites. Assess your shape and make sure you are ready.

Finally, after setting up the wish list and specifying the prerequisites, it is necessary to check that the preconditions are properly satisfied, not just formally but by answering the question: am I in good enough shape? What is required is not very much but is essential for achieving profitable results. As on an adventure trip, where you must be able to walk kilometers over varying landscapes and jump over some obstacles, in this electronic trip you must be able to solve a system of equations, to write nodal equations without panic, and to guess reasonable approximations that do not end up with a million volts or a hundred amps. Therefore, before starting the trip, assess yourself. If you find some weakness, quickly repair it with extra effort and exercises, and ensure that you are ready soon for this exciting electronic adventure.

1.3 ELECTRONIC SYSTEMS

The building that is the knowledge of electronics consists of many floors, with electronic systems on the top. Each floor may be connected by bridges to other knowledge buildings: those of mechanics, chemistry, biology, and also the humanities. Just below the top floor of the electronics building there are the functional blocks used to compose systems. These functional blocks are typically described, at a high level of abstraction, by language, and represented as an element of the block diagram of the entire system – a drawing depicting the sub-systems and their interactions. The flow of signals from one block to another block of the system describes signal exchange. Blocks transform the input signals to generate different outputs.

Figure 1.1 shows a possible block diagram of a system consisting of four sub-systems. There are one or more inputs that can be analog or digital (we shall study this distinction shortly) and are represented by a simple line or by arrowed channels that correspond to one or more wires carrying signals. The inputs are used in one or more blocks (in the diagram we have four blocks, *A*, *B*, *C*, and *D*); the output(s) of each sub-block are the inputs of other blocks and possibly also the input of the same block, for feeding back information to the input (see block *B* in the figure). The system outputs are the inputs of another system, control an actuator (we shall also see what an actuator is), or are stored in a memory for future use.

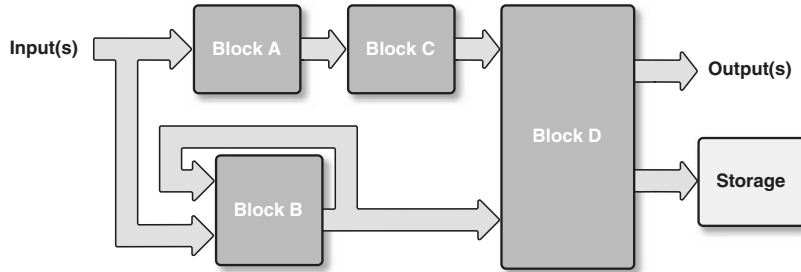

Figure 1.1 Typical block diagram of a system.

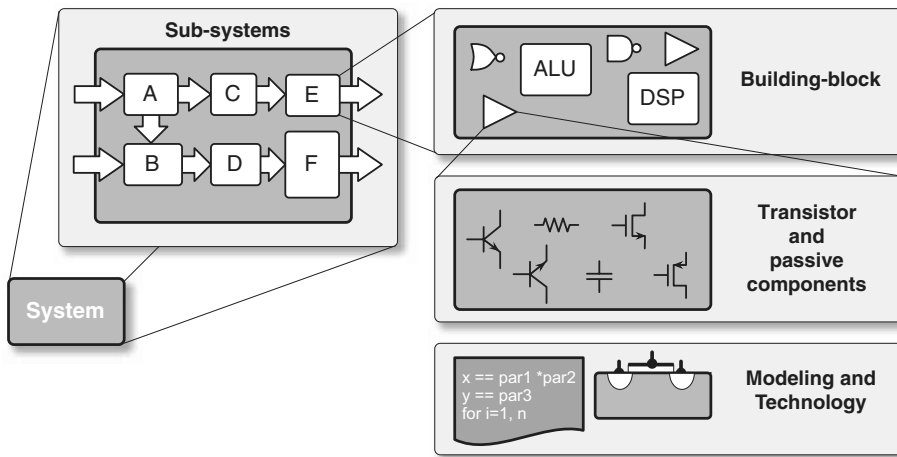

Figure 1.2 Hierarchical description of an electronic system.

The hierarchical description expands the sub-system into electrical functions that are used to produce a given transformation of the input(s) into output(s). They are graphically represented by symbols like the one shown in Figure 1.2. Below this level we have the circuits that realize functions with passive and active (transistor) components. Then the passive and active components are modeled by a set of equations, often represented by a symbol. The components are fabricated using a given technological process. They can be discrete elements that perform simple basic functions or integrated circuits that realize higher-level functions by the cooperative action of many components that are fabricated together on a single chip.

The way the components are assembled is part of the job. We can have a Printed Circuit Board (PCB) or use more modern and compact ways to assemble the system. The PCB has metal traces for interconnections and houses components that may be assembled using the surface mounting technique. Another possibility is to house many chips on the same package to obtain a System-in-Package (SiP). Figure 1.3 shows various examples of systems assembly and wire-bonding. Observe that it is also possible to stack chips one on top of another so as to exploit the third dimension. The choice between different solutions depends on a trade-off between cost, volume, and system reliability.

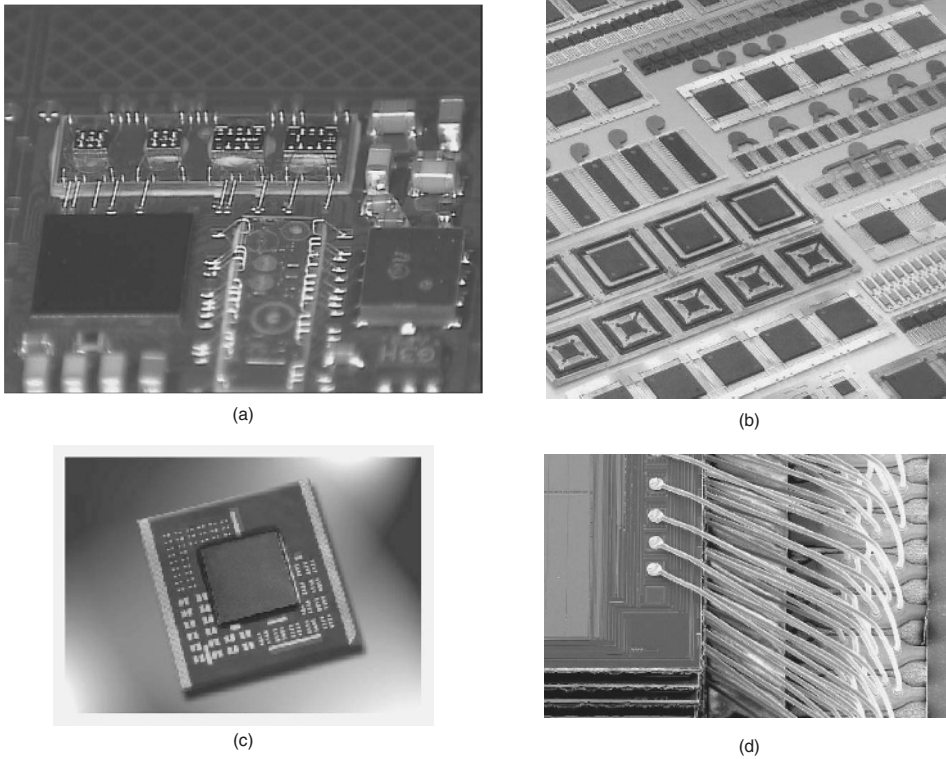

Figure 1.3 (a) Radio frequency module with direct wire bonding for possible SiP; (b) different types of package frames; (c) assembly on a PCB of a flip chip ball grid array circuit; (d) details of very dense wire-bonding. Reproduced by permission of © ST Microelectronics.

Self training

The assembly of a system can involve different techniques. The simplest one uses a PCB. Find on the Web more information about the following.

- What kind of material is used for PCB fabrication?
- What is a multi-layer PCB?
- What is the minimum number of PCB layers required to obtain any possible interconnection, and why, in your opinion, do designers use multiple layers?
- What can we do with those extra layers?

In addition, search the Web and find out what a System-on-Chip (SoC) is, and what a System-in-Package (SiP) is. What are the fabrication techniques used?

Write a short note on the results of your search.

1.3.1 Meeting a System

Very often during the day, even if you are not fully aware of it, you encounter electronic systems. The first time such a system touched your life was probably right after you were born, perhaps when a nurse entered a waiting room crying out to an anxious man (your father): “It’s a girl!” or “It’s a boy!” That man, a bit confused, might have smiled and looked up at the digital clock on the wall, with a large seven-segment display showing, maybe, “9:38”.

The digital clock is an electronic system based on a precise time reference: the quartz oscillator. Probably you know that quartz is the crystalline form of silicon dioxide (SiO_2) used to show a time reference because of its anisotropy (dependence of properties on direction). What happens is that anisotropy also causes piezoelectricity. The name piezo comes from the Greek and means pressure; therefore piezoelectricity refers to electrical effects caused by pressure and, conversely, pressure that determines electrical consequences. When a piece of crystal is subjected to a voltage a stress is produced, and under certain conditions the crystal begins vibrating mechanically and electrically in a steady manner. The good thing is that the temperature dependence of the oscillations is very low: the variation at around 25°C is only $5 \text{ ppm}/^\circ\text{C}$ (ppm means parts per million). Therefore, a quartz crystal experiences an error of 25 ppm with 5°C change. Remember that in one day we have 86 400 seconds; therefore, one second is 11.57 ppm of a day. Accordingly, the error produced by a quartz crystal kept at a temperature 5°C different from the nominal value is about 2 seconds per day.

Because of its accuracy the quartz oscillator is used as the basis of precise clocks. The frequency of oscillation depends on the cut, size and shape. For example a disk of crystal with 1.2 cm diameter and 1.06 mm thickness oscillates at 10 MHz (fifth overtone). For watches the frequency normally used is lower, 32.768 kHz, which corresponds to a period of $30.52 \mu\text{s}$. That frequency is chosen because 2^{15} periods make a second.

The above elements are sufficient for drafting the scheme of a clock that uses seven segments and two blinking dots to display the memorable time of 9:38. Figure 1.4 shows a block diagram with some details. The key, as already mentioned, is the clock oscillator that generates pulses spaced by $30.52 \mu\text{s}$. The next block counts those pulses $32\,768 = 2^{15}$ times and after that generates a pulse at the output. The rate of those pulses is one per second, which is used for the blinking dots. A counter by 60 determines the minutes and another counter by 60 the hours. The content of the counter gives the signals that control the two right-hand digits. Moreover, the pulse of hours is obtained by a modulo 12 counter for determining the two left-hand digits of the clock. As an alternative, the last counter may count by 24 to show the hours of the entire day.

Four seven-segment displays, suitably lit, represent minutes and hours. For this it is necessary to specify special blocks, called seven-segment drivers, that receive the signals from the counters and transform them into segment control. Obviously the signals generated by the drivers must be strong enough (in voltage and current) to power the segments properly; they must be bright and visible even in daylight.

The block diagram is not complete, because it does not include setting the clock and possibly dimming the segments. Moreover, it may be that an advanced implementation includes automatic segment illumination control, using a sensor that measures the illumination of the environment and regulates the power sent to segments.

A second example of a system that some readers will have encountered for a while after being born is the baby incubator. It is used to care for babies in a suitable controlled temperature. I suppose you can easily imagine what its basic functions are: to measure the temperature,

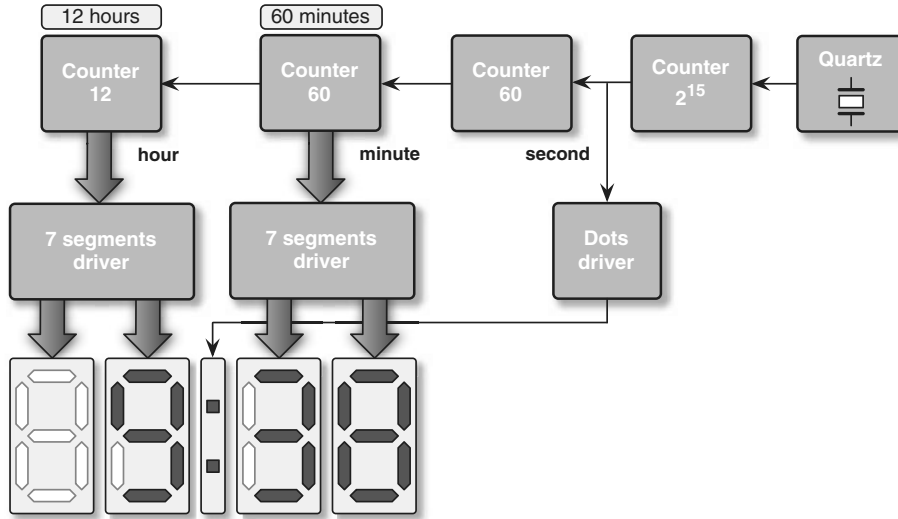

Figure 1.4 Block diagram of a digital clock.

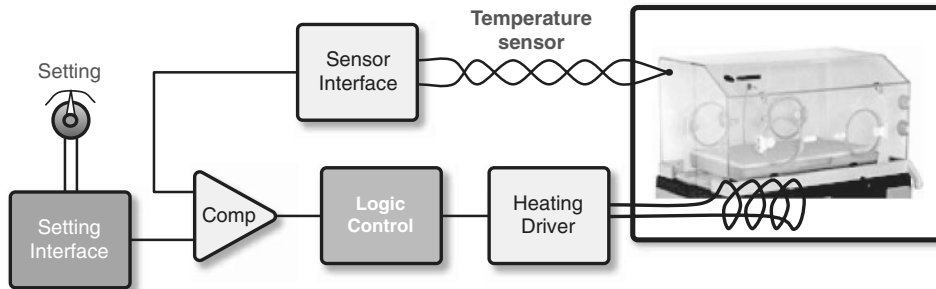

Figure 1.5 Block diagram of an incubator with controlled temperature.

compare the temperature with the desired value and increase or reduce the heating. The block diagram representing those functions is shown in Figure 1.5. The temperature is measured by a sensor that transforms a physical quantity, the temperature, into an electrical quantity, a voltage. The signal generated by the sensor is often not appropriate for use, and, for this, the *sensor interface* must change the output of the sensor into a more convenient signal (higher amplitude, lower output impedance, digital format, ...). The desired temperature enters the system by a setting control defined, for instance, by a knob or a rotary switch. A setting interface possibly transforms the setting into a form compatible with the signal given by the temperature sensor. The block called *comp*, a triangle in the figure, compares the two inputs and produces a logic signal informing the *logic control* whether the measured temperature is higher or lower than the setting. The logic control switches the heating of the incubator on or off by the *heating driver*.

An important feature is that the system uses feedback, i.e., the system sends the output signal back to better control the operation. The feedback is given by the measured temperature. Moreover, the feedback loop is hybrid: it is made up of electrical quantities and physical

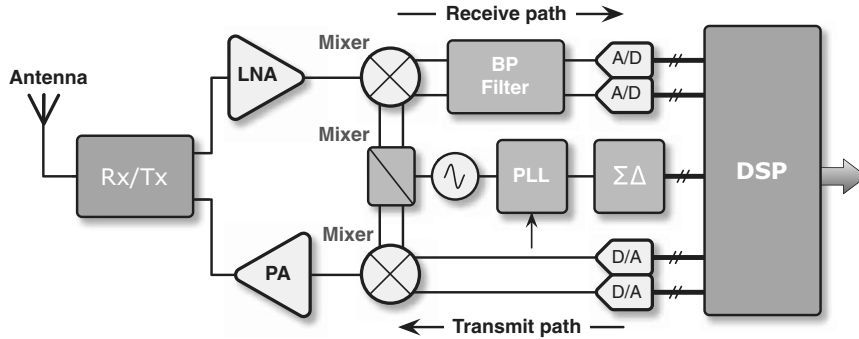

Figure 1.6 Block diagram of a wireless communication system.

quantities (heat and temperature). Electronic systems normally obtain feedback using only electrical signals.

Use hierarchy

The best way to describe a complex system is to split it into basic functions, without many details, and to go down hierarchically inside each block for a more detailed description until you reach the bottom, the physical level.

Another example of an electronic system is a device that we use many times a day: a portable telephone or wireless communication system. It transfers information by translating electrical signals from and to electromagnetic waves. The antenna, the device used for that purpose, operates for both the transmission (Tx) and the reception (Rx) path. A significant parameter is the carrier frequency, often in the range of many hundreds of MHz or some GHz. The signal occupies a frequency interval (signal band) that depends on the carried information and on the modulation method used before the mixer that gives rise to a replica of the input signal at frequencies around that of the carrier. A possible block diagram (albeit approximated) is shown in Figure 1.6. Next to the antenna two triangular blocks indicate the LNA (Low Noise Amplifier) and the PA (Power Amplifier). Then we have mixers, used to translate the signal at higher or lower frequencies. The blocks called *A/D* and *D/A* are the analog-to-digital and digital-to-analog converters, used to change the signal format from analog to digital and vice versa. The block PLL (Phase Locked Loop), controlled by another block, $\Sigma\Delta$, generates the carrier of the mixer. A big part of the operation is carried out by the DSP (Digital Signal Processor), possibly made up of many hundred of millions or billions of transistors. The signals from the DSP and the data converters can be multiple, and, rather than representing them by an arrowed symbol, the figure uses two oblique lines crossing the wires.

Notice that Figure 1.6 uses several blocks whose symbols and functions are difficult to understand fully at this stage of your studies. Don't worry. You will learn about those functions shortly. What is needed now is just an awareness of the hierarchical description of a system. This is similar to what is done with maps. When depicting a country the map just indicates the biggest cities and the most important highways, mountains, big rivers and lakes. Then, going down to the regional level, the maps provide a more detailed view with medium-sized cities, hills, small rivers, and so forth. Below this, the city map level gives details about streets and maybe single buildings.

Self training

Use the Web or other tools to learn about the functions of electronic keys. They can be contactless (using a short-range wireless communication link), with contact, or a mixture of the two. Account for the following options.

- The key needs power but does not have a battery on board.
- The key is used for a car.
- The key operates as a remote control.

Describe the features of the system, indicate the possible options, and draft the block diagram with the main flow of signals indicated.

1.4 TRANSDUCERS

The inputs or the outputs of an electronic system are often electrical portraits of real-world quantities: physical, chemical, or biological. For example, time is a physical quantity represented by a sequence of electrical pulses at a constant pace; temperature is depicted by a voltage that increases as the temperature becomes higher; pressure is measured by the value of the capacitance or the resistance of special materials sensitive to stress. The concentration of a given gas can be detected by the conductance change of thin porous layers that adsorb that gas. Moreover, the output of a system can be a movement of mechanical parts, a variation in pressure, the generation of modulated light, or the activation of a process. The devices that interface real-world quantities with an electronic system are called *transducers*. To be more specific, if the transducer generates an electrical quantity it is called a *sensor*; when it produces an action or, more generally, gives rise to a real-world quantity it is called an *actuator*.

Sensors and actuators

A sensor senses a real-world quantity and generates an electrical signal with given sensitivity. An actuator generates a real-world quantity under the control of an electrical signal.

In the above situations the electronics is just part of a wider system, as shown in Figure 1.7: a chain of blocks with, on one side, a sensor that senses a real-world quantity and produces an electrical signal. This signal is the input of an electronic system that, after some processing, gives rise to a suitable control for driving an actuator, whose output is a physical or maybe a chemical or biological quantity.

1.4.1 Sensors

The real world produces signals in various forms; some are interesting or beneficial, other unwanted or risky. Very important for our daily activity are the acoustic and visual signals; for those we are well equipped with sophisticated senses that perceive and transform the information and carry it to the brain. Other relevant signals are the concentrations of chemical

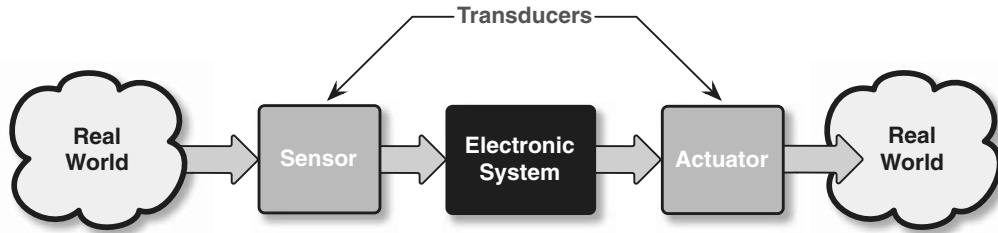

Figure 1.7 Entire system involving real-world signals.

agents that can be pleasant or dangerous. Some chemicals are detected by the nose and the tongue, which are sensitive to gases or solutions of pure elements or a mixture of elements, even in very small concentrations (as for some perfumes and odors). For other chemicals, such as carbon monoxide or water, the nose and the sense of taste have a negligible or null sensitivity; we say that those chemicals are odorless or tasteless. Obviously, for dangerous substances it is important to extend the senses' capability, to enable us to detect their presence and to give warning or take action promptly. For this purpose, often an electronic system enhances or replaces the human one by processing signals and performing actions with the help of sensors and actuators at the two ends.

Let us look at some examples. Temperature is an important physical quantity that, fortunately, is quite easy to measure. A simple temperature sensor is the thermocouple, which exploits the effect discovered by the Estonian physician Thomas Seebeck in 1822. Probably you already know that effect: a temperature difference established between the junctions of two metals determines a voltage across the terminals. Thus, a Nickel–Chromium thermocouple generates 12.2 mV with 300°C at one junction and room temperature (27°C) at the other. Another way to measure the temperature is by using the p–n junction of a semiconductor material (we shall learn later what a p–n junction is). The current across the junction with a fixed bias voltage increases exponentially with temperature; then a logarithmic (the opposite of exponential) circuit enables us to represent the temperature on a linear scale.

Even sensing light (especially in the visible range) is not difficult. There are many simple devices, among them photodiodes, which, again, are based on p–n junctions (or rather more complicated structures). When a photon with sufficient energy strikes the p–n junction in a special electrically activated region, called the *depletion region*, a pair of carriers is freed and produces a photoelectrical current. Figure 1.8 shows various packaged single photodiodes and linear and two-dimensional arrays. The cross section of a simple photodiode in Figure 1.8, whose thickness is in the range of microns (10^{-6} m), shows that the depletion region extends across two different types of doped material and almost reaches the surface hit by light. This feature is important, because the light penetrates just a tiny layer of material. Obviously the package that protects the device from dust and aggressive agents must have a window transparent to the wavelength that the photodiode wants to detect.

Many photodiodes arranged in a rectangular array make an image sensor (as used in digital cameras). Each photodiode detects one pixel of an image that is decomposed into discrete small areas. The number of pixels is, as I am sure you know, the number of dots into which the image is divided (in rows and columns). Therefore, the actuated image is an approximation of the real one through its decomposition into dots. If the image aspect ratio is 4×6 (the postcard format) with 6 M pixels (M means million), the detected or displayed image consists of an

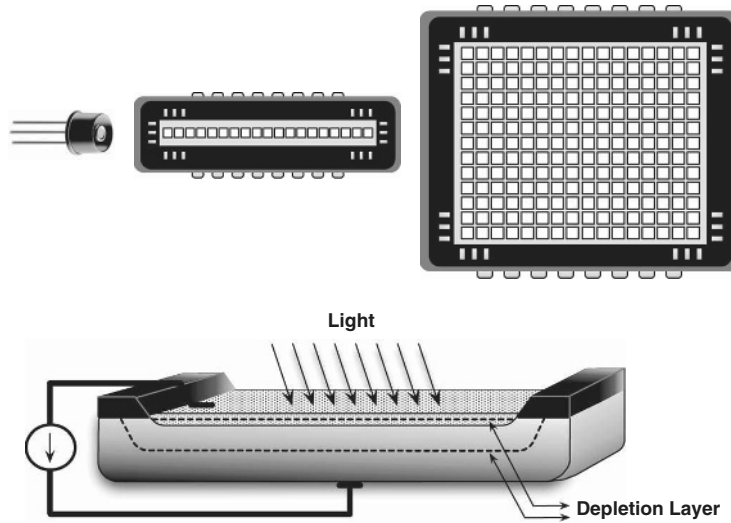

Figure 1.8 Different types of photodiodes and cross section of the device.

array of 2000×3000 dots. Such a resolution, when transferred onto 4×6 -inch photographic paper, gives rise to dots separated by $50 \mu\text{m}$ (or 2 mils).

What is a p–n junction?

This, I suppose, is what you are asking yourself. We shall study this in detail later. For now it is enough to say that a p–n junction is the abrupt change of doping in a semiconducting material (such as silicon or germanium). One part has an *n*-dopant (such as arsenic) added, and the other a *p*-dopant (such as boron). Notice that “junction” here does not mean a simple joining of different materials, but corresponds to a transition of dopant within a mono-crystal. These unfamiliar words will be explained in a later chapter.

Remaining in the area of optical applications, there is an interesting sensor, the Single Photon Avalanche Diode (SPAD), which is capable of detecting the hit of a single photon. The sensor is again a p–n junction, whose biasing is close to the so-called breakdown voltage. A single electron generated by a photon triggers an avalanche of electrons. After a while the avalanche extinguishes. Therefore a pulse of current denotes the occurrence of a single photon.

Self training

Make a search on the Web for different types of photodiodes. Look at the different sensitivities and light wavelengths. Find the right solutions (possibly in terms of cost/benefit ratio) for the following applications:

- crepuscular switch for lighting the pathway in your garden;
- simple barcode reader (assume the use of red illumination in the system);

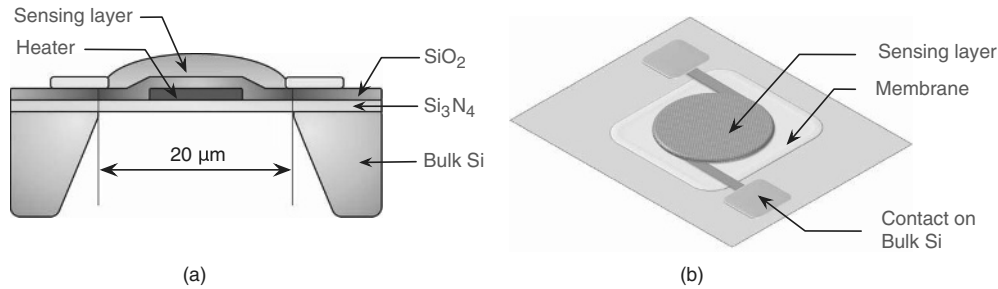

Figure 1.9 Micromachined gas sensor with micro hot-plate: (a) cross section; (b) top view.

- infrared sensor for monitoring hot bodies in a room;
- sunlight ultraviolet monitor (for choosing a sun lotion protection factor).

The sensing of chemical quantities is very important for monitoring the environment and for safety. For example, it is important to detect hydrogen, hydrocarbons, nitrogen oxides, carbon monoxide, oxygen, and carbon dioxide in a variety of ambient gas conditions and temperatures. There are many types of sensor used for chemical sensing; they can be resistive-based or capacitive-based structures. Since the same sensitive structure is often influenced by different chemicals, in order to increase the sensitivity an array of gas sensors with different responses to different compounds (an electronic nose) can be used. The output is obtained by means of complicated calculations involving the single sensor responses. In some cases the sensor is microfabricated or micromachined using Micro Electro-Mechanical Systems (MEMS) technology and/or based on nanomaterials to improve sensitivity and stability.

Figure 1.9 shows an example of a micromachined gas sensor with a micro hot-plate. The structure exploits the change in resistivity of porous materials (such as tin oxide) when they absorb a gas. First the micro hot-plate preheats the sensing layer to expel all gas. Then the measurement can take place after the gas has been absorbed. The layer resistance is measured with high sensitivity, and this is followed by translation of the result into the actual gas concentration. All of these steps require electronic support and some computation, and perhaps the details of how to do that are a bit puzzling. However, what is necessary at this point is not to give answers but to be aware of the possible complexity of electronic systems that use sensors.

1.4.2 Actuators

As already mentioned, an actuator generates a real-world quantity. The more common kinds of actuators are for audio or video outputs. For audio we have, for example, the loudspeaker and noise canceling headsets. For video signals we have many types of display that light two-dimensional arrays of colored dots. Examples are the Plasma Display Panel (PDP) or the thinner and lighter Organic Light-Emitting Diode (OLED) display. There is also the DLP (Digital Light Processing, by Texas Instruments). This is a video system using a device, the DMD (Digital Micromirror Device), made up of a huge number of micromirrors whose

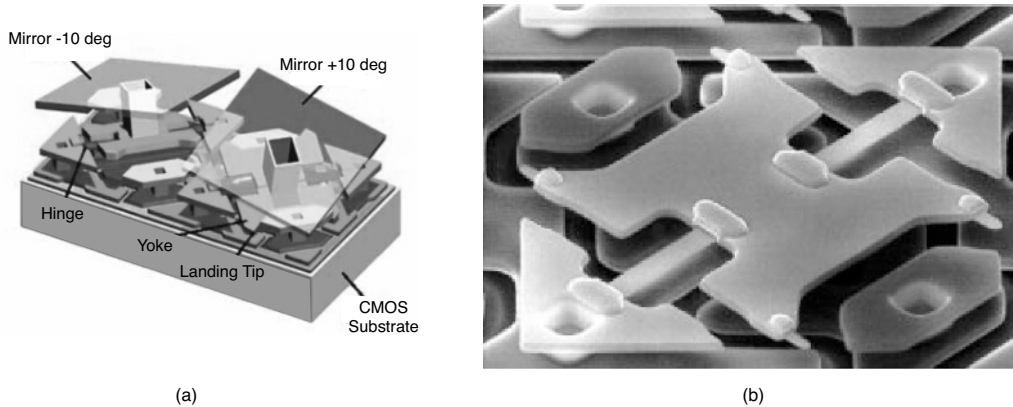

Figure 1.10 (a) Micromirror structure (DMD™, Digital Micromirror Device) used in DLP. (b) Microphotograph of a DMD. Reproduced by permission of © Texas Instruments.

sizes are as small as 10–20 μm . Figure 1.10 shows the three-dimensional view of a DMD, microfabricated by a CMOS-like process over a CMOS memory (CMOS is a term that will be explained fully in a later chapter). Each light-switch has an aluminum mirror that can reflect light in one of two directions, depending on the state of the underlying memory cell. Electrostatic attraction produced by voltage differences developed between the mirror and the underlying memory cell determines rotation by about 10 degrees. By combining millions of DMDs (one per pixel) with a suitable light source and projection optics, it is possible to project images by a beam-steering technique. Reducing the beam steering to a fraction of the pixel projection time produces grayscale. Colors, by the use of filters, are also possible.

Another actuator widely used for video is the LCD (Liquid Crystal Display) panel, used in projectors, laptop computers and displays. LCDs are used because they are thin and light and draw little power. The contradictory term “liquid crystal” indicates that the material takes little energy to change its state from solid to liquid. Its sensitivity to temperature is one of its features, as verified by the funny behavior of your computer display if you use it during hot days on the beach. The main feature of the LCD is that it reacts to an electrical signal in such a way as to control the passage of light. This property is used in the transmission, reflective or backlit mode, to obtain grayscale images. The use of filters enables colors.

The abovementioned DLP is a sophisticated example of MEMS, which integrates mechanical elements, sensors, actuators, and electronics on a common silicon substrate by microfabrication technology. Electronic circuits are made by an Integrated Circuit (IC) process. Micromechanical components are fabricated using the same processes, where they are compatible with micromachining: a selective etching away of parts or the addition of new layers to form the mechanical and electromechanical devices. We have many MEMS used as sensors or actuators. A further well-known example of MEMS, actually a sensor, is the accelerometer used in crash air-bags for automobiles.

In addition to fully integrated solutions we can have hybrid micro-solutions like the one shown in Figure 1.11. In this case, rather than realizing sensor and circuit on the same silicon substrate, the components are separated and are possibly fabricated with different technologies: the sensor is a MEMS with little electronics on board, and most of the processing is done by a

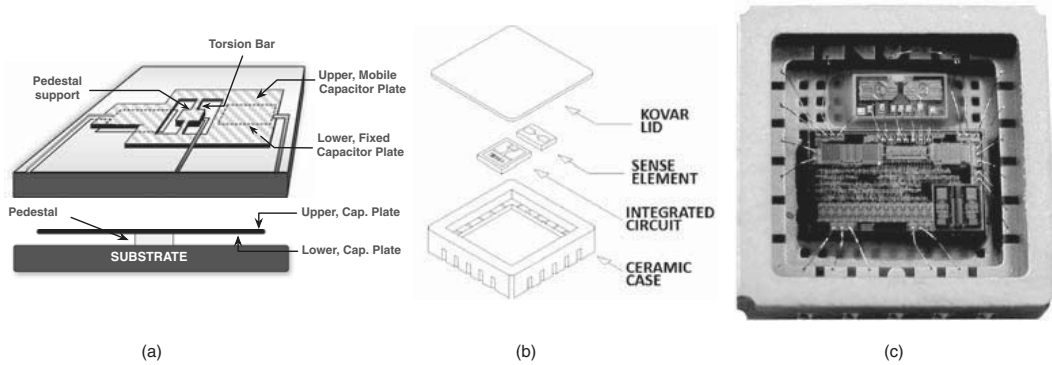

Figure 1.11 (a) Micro structure of an accelerometer; (b) assembly diagram of the System-in-Package. (c) Microphotograph. Reproduced by permission of © Silicon Designs, Inc.

conventional integrated circuit. The parts are micro-assembled on a suitable substrate (such as ceramic) and sealed on the same package to obtain a so-called System-in-Package (SiP).

Obviously, in addition to the actuators fabricated on silicon, we have many other types of actuators fabricated by conventional methods, some simple and affordable, others complicated and expensive.

Testing

Before delivering electronic circuits or systems it is necessary to verify their functions by testing. If the input is an electrical quantity it is not difficult to generate something similar for this purpose. The operation is much more complicated if the process involves non-electrical quantities, in which case it requires the use of a controlled non-electrical signal at the input.

Important aspects of the production of electronic systems are the packaging (sealing of the system so as to ensure protection and mechanical stability) and the testing, i.e., the verification of system performances that must correspond to those expected (the specifications). In the case of systems with sensors or actuators the packaging can be problematic because it is necessary at the same time to protect the system from undesired aggressive agents and to allow the desired quantities to interact with it. Testing is also a problem because it does not involve just electrical signals. For such systems, packaging and testing should be accounted for at an early stage in the design (and this is a good recommendation for any system, even one without transducers).

Although this book does not specifically deal with sensors and actuators, it is necessary to be aware that transducers can be essential parts, and that the design and specifications of the entire system depend on the features (such as sensitivity, accuracy, and conditions of operation) of the sensors and actuators used.

1.5 WHAT IS THE ROLE OF THE COMPUTER?

I suppose that at this point a natural question concerns the role and use of the computer. Indeed, the complexity of modern electronic systems cannot be handled with paper and pencil,

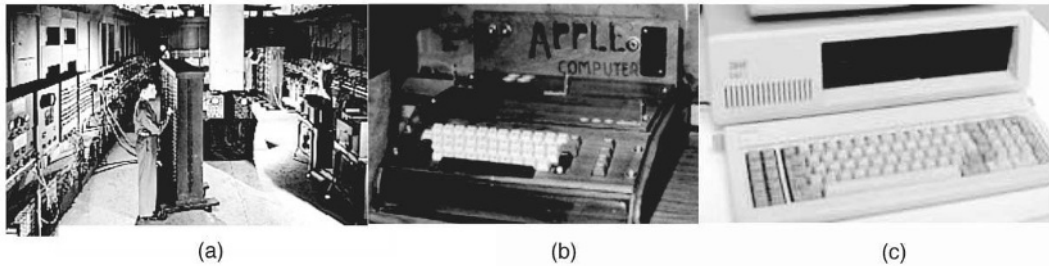

Figure 1.12 Evolution of the computer: (a) ENIAC – 1946; (b) Apple I – 1976; (c) IBM 5151 – 1981.

and probably just reading this book on paper instead of looking at a bright monitor seems funny. The answer to the question is: yes, of course, computers and simulation programs for circuits and systems are important tools for electronic design, and, aware of this, the educational method followed by this book expects their massive use.

However, before talking about computer programs it is necessary to linger a little while on the role of these tools in both designer activity and the learning process. Definitely, computers are amazing machines that make the modern age what it is. Without them we would not have access to the knowledge and comforts that we now take for granted. Computers process information for us and they do it fast – much faster than we can; they solve problems and provide solutions. The progress of computers over the years is such that problems and calculations that used to take many months or years can be solved in fractions of a second. That is the good news, but let’s think a little bit on this point.

Many years ago (but not so very many), the first computers were a set of big boxes like armchairs surrounded by air conditioning and controlled humidity. The instruction set was entered by punched cards, and a suite of programs took hours, or even a day. The user had to deposit his or her deck of punched cards in a tray, and somebody in a white coat periodically came out of the mythical computer room to take the decks inside one by one. Just a small mistake required a new run and hours of waiting. The speed of the computer (or actually of all the steps: punching cards, walking to the computer center, printing results on paper, delivery of results) was very slow, and often the speed in realizing a mistake was so fast that the user understood the run was useless before receiving the answer. “That’s very bad!” I suppose you will cry, but, indeed, the so frequent frustrations caused by mistakes taught people to be very careful before launching a run. The computer evolved rapidly, much more ahead than what is shown in Figure 1.12, but the first generations of computers left a good amount of time for thinking about results before receiving them. And that is what was good: having time to use and exercise the brain.

Friendly suggestion

Do not allow the computer to be faster than your brain. After receiving any simulation outcome, stop and wonder. You will find something useful hidden in the results. Certainly – and surprisingly – you will find something that helps your understanding.

Now the speed of machines is much greater than the speed of the brain, and the answer is received before the brain is able to formulate a logical prediction. Consequently, it seems

convenient to many to just try and see what happens. This attitude is more general: to perform an addition, even a very simple one, very often a pocket calculator is switched on so as to discover with a few finger strokes that $13 + 26$ equals 39. Isn't it so? That's funny and, in some senses, not a serious problem. Everybody, I suppose, assumes that using the brain for that simple operation is useless. This is truer for more complex calculations. Multiplication or division of numbers with many digits would require at least a piece of paper and a pencil; thus, of course, the use of a pocket calculator is the best solution.

Using calculators is almost beneficial, but there is a small problem: the use of a pocket calculator provides a "mathematical" and not an "engineering" result. For example, the value of a current can turn out to be 21.47321832 μA but is it believable that the last two digits, or even more than two, make sense? The minimum measurable current can be in the nano- or the picoampere range but not in that of the attoampere (10^{-15} A). Therefore, using a calculator possibly conceals the meaninglessness of results.

The situation was different, or even the opposite, in the past, when division and multiplication were calculated by using the slide rule: a funny instrument that engineers used, made of two parts, one sliding inside the other. The basis of the slide rule is the logarithm, or, better, the property that $\log(a \cdot b) = \log(a) + \log(b)$ or $\log(a/b) = \log(a) - \log(b)$. The two parts of the slide rule were used to perform the addition or subtraction of logarithmic segments, and this involved possible errors in aligning segments and in reading results. The accuracy was limited and evidently could not exceed three or four digits – much less than what can be got from the computer.

I won't go further down in this archaeological description of ancient tools used before the computer, but I should make a remark. The results obtained with the slide rule were clearly approximate and definitely had lower accuracies than those obtained with a normal computer. "That was not good!" I suppose you think. But you are partially mistaken. As already outlined in the case of current, having too-precise results is nonsense. Precision is not the real world. In engineering disciplines, precision that is much higher than the roughness of real things or the fast fluctuation in time of real quantities is just a waste of resources.

There is another point to mention. We have to give the right credit to microelectronics. Indeed, computers are not just software but are primarily hardware or, better, electronic circuits. Progress in the computer area is largely due to the improvements in electronics that increased their effectiveness in terms of larger numbers of transistors, smaller areas and volumes, lower consumed power and diminished cost per transistor. Maybe you know about the prediction of the so-called "Moore's Law" made by Gordon Moore, the Intel co-founder, who in 1965 stated the following:¹

The complexity for minimum component costs has increased at a rate of roughly a factor of two per year . . . Certainly over the short term this rate can be expected to continue, if not to increase. Over the longer term, the rate of increase is a bit more uncertain, although there is no reason to believe it will not remain nearly constant for at least 10 years. That means by 1975, the number of components per integrated circuit for minimum cost will be 65 000. I believe that such a large circuit can be built on a single wafer.

The prediction is normally summarized by saying that progress is almost exponential with a doubling of performances every two years (or, using a more aggressive forecast, every 18 months), and, indeed, the rule was almost confirmed by the market and advances in

¹From "Cramming more components onto Integrated Circuits", *Electronics Magazine*, 1965.

technology for more than four decades. The result is that for some categories of integrated circuits the complexity now exceeds several billion transistors and speeds have reached several hundreds of GHz.

Obviously this growth cannot continue forever. Also, the improvement is not the same for all of the parameters. For example, transistor technology growth is not accompanied by an equal improvement in processing speed or power reduction. To improve performance it is necessary to use more and more transistors, and the consumed power can become a significant limit.

1.6 GOAL AND LEARNING STRATEGIES

What I have said above is not an attack on the computer and modern simulation tools, but is just given in order to define goals and learning strategies better. For this purpose, it is worth remembering that expertise in any technical field means a proper blending of six different kinds of proficiency: background notions, unconscious expertise, specific knowledge, teamwork attitude, creativity, and ability in using tools.

- **Background notions** Electronic background knowledge means understanding systems, architectures, processing methods, languages and implementation techniques. It is not only a matter of knowing new material so as to participate in generic meetings but also of having a clear, complete spectrum of solutions so as to be able to identify the most appropriate approach.
- **Unconscious expertise** Behind the background notions there is this kind of technical expertise. It results from the slow and long-range absorption of notions studied at school, apprehended by reading books, and resulting from success stories as well as from technical failures (which are much more important than easy successes).
- **Specific knowledge** Every electrical engineer has specific expertise in one of the different facets of the profession. Indeed, in addition to the basis it is necessary to go deeper into detailed knowledge of solutions and practical implementations.
- **Teamwork attitude** The design of complex systems demands a spectrum of knowledge that is not possessed by one single person. This is why activity in electronics is often carried out by teams of engineers, and the attitude towards working with others is an important quality. Among other requirements it is important to be able to communicate, to write reports and to make technical presentations.
- **Creativity** The success of a product greatly depends on quality, reliability, and often style. For quality it is important to ensure optimum execution; for reliability it is necessary to follow strict procedures and controls; for style the exterior aspect, colors, and trends are important. But in addition it is necessary to include innovation, and this is the result of creative activity. Therefore a bit of creativity, balanced by execution, procedures, and care for fashion, is essential.
- **Ability in using tools** Any activity requires proper tools. For electronics, various Computer-Aided Design (CAD) programs obtain a reliable forecast of the operation of circuits and systems before they are fabricated. Other tools verify the correctness of the

transformation of a logic behavior into a schematic and then into its physical realization. Others facilitate the PCB design.

The first two proficiencies don't need further recommendations; it is probably worth discussing the others a little bit more.

1.6.1 Teamwork Attitude

Today's electronic designers cannot work alone. There are so many demands, tasks, and varied sources of information required that the job needs the support of others. We have all learned at home and at school to compete as individuals for awards, attention, and prizes. But the reality is that teamwork obtains the optimum.

Team skills are quite different from those of competing individuals. They involve cooperation, mutual support, and accountability to the team. Therefore students need to learn together to acquire the skill of developing new ideas and new methods of working together. An individual alone has but limited perception of the range of possibilities in a situation. A team develops a variety of abilities and so widens the scope of available information, options and ideas. As a result, the quality and effectiveness of individuals is enhanced because a team can help to explore hidden factors.

One of the key benefits of teamwork is synergy. It multiplies the resources of participants through the interaction of a variety of contributors, who see a problem from diverse perspectives. However, as the size of the team becomes large (the optimum is around five people) the efficiency of it diminishes because of the negative contribution of "anchors." Moreover, it is important to have in the team complementary attitudes. There must be a "manager" who keeps the project on track and on time; for this a highly organized person is necessary. A warning generator is also needed, and a problem solver and an hard routine worker. Having a creative person is also important for exploring new avenues and for stimulating the team.

The above points will be helpful in case part of the learning process involves team activity (which I strongly encourage). The formation of the team and its working activity must be carefully considered to obtain the best effectiveness.

1.6.2 Creativity and Execution

The key word of many electronics companies is innovation, but this word implies different issues and strategies. You, as a future electrical engineer and very likely an employee of a high-tech company, must be prepared to contribute to innovation. Having innovative products is a company strategy that involves both creativity and execution. Generating new architectures, new electronic functions and new circuits is important, but poor execution of the invented ideas can be a source of failure. Therefore, it is important to value creativity but not to rely heavily on it. A correct balance of the two aspects is the optimum, but in the market we can find successful companies that focus more on creativity and others excelling in execution.

Innovation, creativity and execution are topics studied in many business schools, and this is not the right place to go into further details. However, while having the issues in mind you should analyze your attitude and, possibly, try to reinforce your proficiency in areas where you are not so strong. To improve execution it is necessary to do exercises that refine the ways in which methods and techniques are implemented. For creativity, unfortunately, there is no one

recipe; there is just the recommendation to avoid saturating your mind with notions and to keep vital your technical and scientific curiosity.

Another point to remember is that both creativity and ability in execution are part of your added value: the assets of your future professional career.

1.6.3 Use of Simulation Tools

Proficiency in the use of simulation tools is not just a matter of knowing how to use the tools and how to generate results but, much more, it is about how to analyze results and to be able to understand limits and opportunities. When experts design a circuit or a system they already have a given function and a given response in mind. The simulation serves to verify the idea and to find out the possible limits of the approximate reasoning. If the result is not what is expected, the expert uses rules of thumb to modify the design in the proper direction. Moreover, simulation results are used to refine the rules of thumb and account for second-order effects. Therefore simulation tools aid the designer, and the programs used for it are called Computer-Aided Design (CAD) tools. These tools support the design at various levels of abstraction. The study of architecture is normally done by using languages or behavioral descriptions; the study of circuits uses electrical networks and models of the electronic components.

When the design activity becomes routine, without a concrete contribution from the designer's skill, the computer helps in performing repetitive steps automatically, and, in this case, we talk about Electronic Design Automation (EDA). For example, when there are design rules for avoiding fabrication errors (possibly caused by inaccuracies in the process), those rules are verified with a design automation program. The design of a PCB requires some skill in component placement, but the physical design of the layout (the routing and dimensioning of traces, the choice of the layer where they run) can be done automatically.

Keep in mind . . .

the key difference between CAD and EDA tools. CAD programs aid designers in their technical activity, providing elements useful for assessing the operation of the circuit and helpful guidelines for the design flow. Design automation tools are used to replace the designer in routine tasks.

Design automation programs must use algorithms capable of meeting any possible situation and level of complexity. Therefore, for simple cases a manual solution can be more effective than an automatic one, but for very complex architectures automation is the only possible solution. Since analog circuits normally require a small number of components while digital circuits count hundreds of thousands or many millions of transistors, automation is much more suitable, and more often used, for digital architectures than it is for analog schemes.

1.7 SELF TRAINING, EXAMPLES AND SIMULATIONS

This chapter has already used a special inset called “Self training” to suggest Web searches for private study on specific topics. There are also boxes with clarifications or warnings. These insets and boxes are, in some sense, small breaks needed when the complexity of new concepts causes stress. They also help in the complex mechanism of learning a new subject.

Indeed, learning is the result of a proper blending of five features:

- learning as memorizing, storing simple information that can be reproduced without significant changes;
- learning as a quantitative increase in knowledge, or just collecting information – in this case the information is stored as rough notions;
- learning as acquiring skills and methods that can be retained as background knowledge and used when necessary;
- learning as making sense or abstracting meaning – this kind of learning involves relating parts of the subject matter to each other and to the real world;
- learning as interpreting and understanding facts in a different way, which involves comprehending the world by reinterpreting knowledge.

There is a substantial difference in quality (and difficulty) between these five features, which we can summarize by “knowing that” or “knowing how.” Obviously, the aim of this book is toward the more difficult “knowing how,” but a bit of “knowing that” is necessary because it provides new facts and practical details and also helps in contextualizing study and avoiding unnecessary theoretical abstractions.

In addition to “Self training” the book has “Examples” with solutions, and, much more, “Computer Experiments” for simulations of systems or circuits in an environment that looks like an electronics laboratory. Moreover, as in all textbooks, there are problems given at the end of each chapter.

1.7.1 Role of Examples and Computer Simulations

It is well known that examples and training sessions facilitate the learning process. This is also what is implied by the saying: “If we hear, we forget; if we see, we remember; if we do, we understand.” Well, if you read a book or are taught any technical subject without seeing examples, your performance, merely after reading, is not good. Acquired theoretical knowledge is often accompanied by perplexity, insecurity, uncertainty, and doubt.

If the above is true for any technical subject, it is surely so for electronics. There are two extra elements here causing uncertainty: the complexity of systems and inaccuracy in fabrication. The complexity obliges us to use approximations that, often, are difficult for others to comprehend. The inaccuracy in fabrication makes the predicted results not exact, as in mathematics, but only within a given range, part of which can be unsuitable for use. Since electronic designers must become accustomed to uncertainty and inaccuracy, examples and computer simulations are extremely beneficial for the learning process. The expected benefits gained are to:

- **Overcome incredulity** Very often the results of a theoretical description made with doubtful approximated assumptions are unconvincing. The outcome seems too simple, not general enough, or maybe simply unbelievable. Numerical examples together with plausible computer programs help to change those possible mindsets.
- **Understand the limits of approximation** The simple models used for hand calculations are often too approximate and can generate misleading results. Nevertheless,

simple equations and simplified rules are keys for directing the designer's activity. The use of more precise computer aids verifies the rules of thumb and facilitates understanding when they fail.

- **Reinforce knowledge** This is a general beneficial effect of using examples and computer simulations. For electronics, since often knowledge is not codified by reliable equations or reasonable rules, using examples and computer verifications is particularly helpful.
- **Learn rules of thumb** The use of rules of thumb is very common in expert designers' activity. They know, for example, what is necessary to increase the gain of an amplifier or improve its speed. They know what the limits of a circuit or the technology used are and they are aware that it does not make sense to continue trying to improve performances above a given limit. This kind of expertise is the result of many observations, mistakes, and achievements. Therefore, with examples and simulations it is possible to accumulate knowledge that is codified in a set of rules of thumb.

1.8 BUSINESS ISSUES, COMPLEXITY AND CAD TOOLS

Before talking about CAD tools it is worth remembering that the activity of any electronics professional requires a little bit of knowledge about financial implications. Of course high-tech products must be sold at a profitable price, and this critically depends on the proper blending of technical and non-technical issues. Designers tend to focus on performance-related themes, while the concern of managers and marketing people is mainly with business. An important factor for success is ensuring low time-to-market. In a highly dynamic business like microelectronics a delay of a few months in releasing new products reduces the return on investment, perhaps to zero. Therefore, having quick design cycles is extremely important.

Another relevant element is, obviously, the cost. Financial studies distinguish between two cost components: fixed and variable costs. Fixed costs are made up of all the expenses not related to the number of circuits or systems sold. The variable costs directly depend on the manufactured parts, and are proportional to the volume of production.

What makes the microelectronic market problematic are the large fixed costs. In addition to traditional ones there are the high costs of research and development, and, much more, of the equipment needed for fabrication. The various fabrication steps that lead to an integrated circuit use a set of masks that define patterns on the silicon surface. This set of masks, especially for nanometer technologies, costs a lot of money. Thus the design must be perfectly functional the first time it is tried, so as to avoid the costs of a new set of masks. The fabrication plant used to process integrated circuits is extremely expensive with a relatively quick obsolescence. Consequently, the use of the plant must be optimal, with a large number of circuits fabricated together (batch fabrication). Similar requirements hold, though to a lesser extent, for the design and fabrication of microsystems that assemble discrete components.

1.8.1 CAD Tools

The requirement for a short time-to-market and cost-effective developments impose the need for a quick and reliable design cycle without the necessity for redesign. For this it is necessary to perform extensive simulations that verify the expected operation in all the possible conditions.

The designer uses computer programs to verify the correctness of system architectures and to estimate logic and electrical behavior. These programs also consider the effect of fabrication inaccuracy and estimate the probability of malfunctioning. They estimate parasitic terms and provide the information for re-simulating the circuit with the parasitic limits included. The tools also help the designer in critical parts of the job; for example, CAD tools optimize the physical placement of cells and make sure that performances are as expected.

1.8.2 Analog Simulator

The simulation tools used to study the electrical response of circuits derive from a program named *Spice* (Simulation Program with Integrated Circuit Emphasis) developed many years ago at the University of California, Berkeley. It uses a description of the electrical network, the netlist, that describes components and interconnections. The netlist generates a set of nodal equations based on linear or non-linear models of the components. The models use the electrical variables of the devices and, also, employ additional variables and nodes internal to the devices, introduced to specify them better. The resulting large system of integer-differential equations is solved by using the methods of numerical analysis.

The solution methods use the so-called LU factorization system, which factorizes the system of equations into two matrices: L , a lower triangular matrix and U , an upper triangular one. When it is required to solve non-linear equations the simulator employs methods like the Newton–Raphson algorithm, which proceeds in an iterative manner until it obtains the required accuracy. Since studies in the time domain need to estimate time integrals, the tool performs the numerical estimations with trapezoidal elements and appropriate time steps. The time step is critical for obtaining the overall accuracy. However, if it is too small the simulation time becomes unacceptable. The circuit simulator speeds up the process with an automatic control that adapts the time step to the signal’s rate of change.

All the steps of this simulation are automatic. Moreover, graphical interfaces facilitate the description of circuits and the analysis of results. Suitable post-simulation tools plot waveforms of voltages and currents. For linear or linearized systems, the tool simulator operates in the frequency domain. It enables, among others, the following types of analysis.

- **DC analysis** This is a Direct Current (DC) study that determines the operational point of the circuit. It is done before applying time-variant signals. It is automatically performed in order to determine initial conditions.
- **AC analysis** AC stands for Alternating Current. The analysis refers to a linear circuit or assumes linearized behaviors. This is the so-called small signals analysis (it is defined in a later chapter).
- **Transient analysis** This is the study of the response to inputs that change with time. For example, it determines the response to a step on top of the initial conditions previously determined by the DC study.
- **Noise analysis** This is made to determine the contribution of unwanted signals, called noise. We shall learn that noise affects any electronic component, being caused by fundamental limits. Knowing the level of noise that affects a signal is essential.

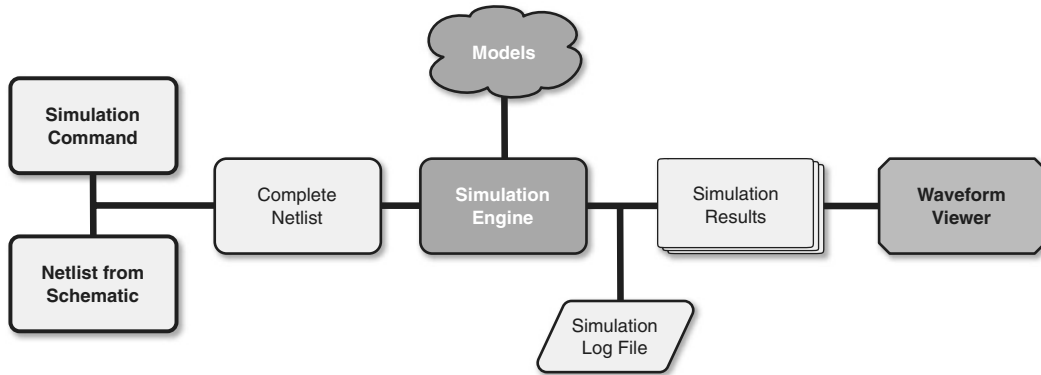

Figure 1.13 Block diagram of *Spice* architecture and functions.

- Monte Carlo analysis** This is a statistical study of performance. Values and performances of real components differ from the expected ones because of errors in fabrication. This analysis statistically changes design parameters to reproduce the effect of fabrication errors over a set of circuit samples.

Figure 1.13 shows a simplified flow diagram of the *Spice* program. The schematic generates a component netlist that is combined with the simulation commands to generate the complete netlist. The simulation engine, the core of the tool, builds the system of equations and calculates the solutions. The results depend on the equations of the components' model. The output is given in two files, a log and a file of simulation results. A graphic section uses the latter to show, on the computer monitor, waveforms of the results obtained.

1.8.3 Device and Macro-block Models

The accuracy of the models of circuit elements determines the closeness of simulation results to experimental measures. The models portray, at various levels of detailed description, the electrical behavior of a single device – such as a resistor, a capacitor, or a transistor – or can represent the task of a macro-block made up of many components.

Models can describe with high precision static, dynamic, and temperature behaviors. They refer to specific technologies and follow the evolution and the improvements. For example, the scaling of the technology of transistors requires the use of very complicated models that also include three-dimensional effects. Since the accuracy of the model influences the precision of results, manufacturing companies and customers fix models and model parameters to guarantee the expected performance. The transistor models of advanced processes are more and more complex, with a very high number of parameters. Often, the circuit designer does not understand the role and relevance of various parameters, and assesses only the global description.

The use of complex device models obtains accurate results but, for a large system, makes the simulation time extremely long (a week or more, even with powerful computers). For this reason a detailed study is normally postponed to the last step of the design flow. The architecture feasibility can be verified with less accurate results, by using, for example, a system-level simulator or simplified macro-block models.

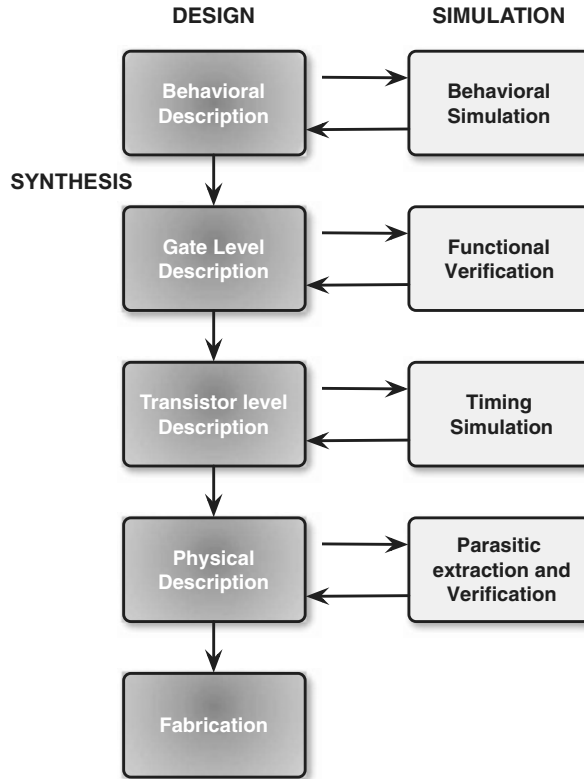

Figure 1.14 CAD tools helping various phases of a digital design.

1.8.4 Digital Simulation

Since digital integrated circuits can include many millions of transistors, studying such large circuits cannot go into the details of a single transistor's operation. What is normally thought sufficient is to ensure logic and timing functionality. Luckily, representing a logic one or a logic zero does not need much detail about amplitudes. It is just necessary to have the expected function at the right time with all possible input conditions.

Digital design and digital simulation follow a top-down approach. At a high level we describe functions with a behavioral language. Then automatic tools transform (or, better, synthesize) the behavioral description into a gate-level netlist, followed by the transistor-level representation and the physical definition of the digital circuit. Simulation tools assist all those phases as shown in Figure 1.14. Notice that the focus at the transistor level is mainly on timing verification.

Simulation tools are used not just for integrated circuits but also for systems made up of prefabricated parts. For the realization of digital functions it is possible to use special devices such as gate arrays, microprocessors and DSPs. Specific CAD tools help with the use and settings of these complicated devices (we shall learn what they are and how they work shortly).

The verification of performance uses signals at the device or system inputs. These must enable control of the correct operation of the entire circuit. Suitable stimuli are used for both analog and digital circuits. However, the complexity of digital systems means that special attention must be paid to the choice of input signals and where to apply them. It may happen that the simulation or the experimental verification is not able to check correct operation of the complete circuit. If some sections remain inactive, there is no test of the function of those sections. To exercise all the individual components of the circuit it can be necessary to use complicated stimulus patterns and to specify signal injection in internal nodes, used just for testing purposes. However, the use of complicated test patterns produces over-long simulation and testing times.

1.9 ELECTRONIC VIRTUAL STUDENT LAB (ElvisLab)

The saying “if we do, we understand” is so true that I put quite a lot of effort into allowing you to do that. CAD tools and circuit simulators are very good aids. *Spice*-like programs that run on a personal computer are available for free, and thus you can use them to study simple circuits. For transistors or other special components you can use models provided by silicon foundries or those available on the Web. The book facilitates simulation sessions by proposing several examples and problems. However, real doing is doing experiments. With an electronic circuit this means changing inputs and seeing what happens at the output; using strange operating conditions and seeing how the output deteriorates. This is what you can do in an electronics laboratory by playing with source generators and instruments connected to a circuit. You can build the circuit yourself, or the circuit might be pre-built, with instructions that guide the experiment.

This book uses an alternative option: doing experiments in a virtual electronic laboratory with plenty of virtual instruments and pre-built circuits or systems. With these you can change the inputs, see what happens and try to understand why. There are two advantages: the circuit never blows up, and instruments do not break down. You can stay in the laboratory and do experiments for as long as time you need or like to do so, without waiting for it to be available.

The name of our tool is *ElvisLab*, an acronym standing for ELectronic VIRtual Student Lab. It is accessible at <http://ims.unipv.it/~ElvisLab/> and it will be made available on request to the professor or the instructor who uses this book to teach you microelectronics. The use of *ElvisLab* is straightforward, and, as you certainly expect, does not require the reading of an instruction manual. The home page of the program gives the catalog of experiments, divided into chapters. Some experiments are proposed in this book, but you can also find other, extra ones.

Almost all of the exercises divide the screen into five sectors. The top left area is the console, with buttons or numerical steppers that change the input parameters. The other sectors present the scheme of the experiment, and display waveforms or diagrams. Three buttons on the top right allow you to return to the home page, to get help and hints, and to obtain some general information on the use of the program. If you click on the bar of a small window that window replaces the large ones, so as to show the details in it better.

Figure 1.15 is a screen view. The console shows numeric steppers for changing the example parameters. At the top of each of the four buttons is the name of the variable and the actual value that can change in a linear manner between the limits indicated by the bar. The main window contains the schematic of the circuit, using pictures of instruments that look like what

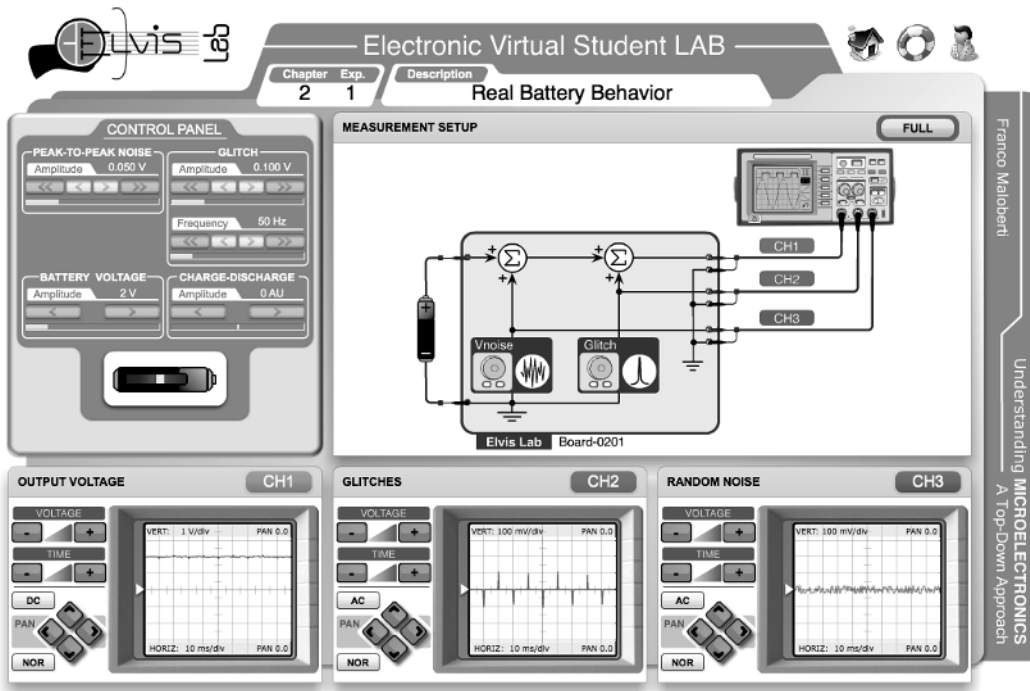

Figure 1.15 Screen snapshot of the first *ElvisLab* computer example. Reproduced by permission of © Microelectronic Department, University of Pavia, Italy.

can be seen in a real laboratory. What is seen in the figure is an oscilloscope, an instrument that displays how repetitive waveforms change with time, beginning from a defined point in the waveform period. The result is an almost stable plot representing the waveform in a defined time interval, as established by the oscilloscope scale controls.

The oscilloscope in the figure has three channels, whose waveforms are displayed in the three small windows. They use time as the horizontal scale and voltage as the vertical scale. The program uses default axis intervals, but when the vertical amplitude becomes too small or too large you can adjust the waveform view by clicking the buttons. When the waveform is in the main window, moving the marker displays the coordinates of that point of the curve.

The help button pops up the example description also reported in this book. The document requires you to do something specific, but, of course, you are free to change and look at whatever you like. I think that the description here is more than enough. You now just have to go to the *ElvisLab* address and check out its features using one of the numerous computer experiments.

Obviously the virtual laboratory is an option that does not exclude real experiments in a real laboratory. If you have that possibility you will have a double chance “to do in order to understand.”

PROBLEMS

- 1.1 Write a list of results that you expect to obtain from the study of this book. Identify the possible weakness of your present knowledge and define a plan for making yourself ready.
- 1.2 Describe the operation of the electronic key of a car. What is the function of the buttons? What is the energy stored in the battery (find this data from a search on the Web)? Estimate the average energy necessary for a single opening.
- 1.3 List the sensors that you have at home, and find out which type of electrical quantity they detect. Distinguish between normal sensors and ones realized with silicon technology.
- 1.4 Modern cars use several actuators controlled by electronic circuits. List four of them and find out the type of electrical quantities necessary for driving them. What is, in your opinion, the actuator that needs most power?
- 1.5 Draft the architecture of a system for the automatic control of a fresh-water aquarium. It is required to feed the fish every second day (the food is in the form of small capsules) and top up the tank's evaporated water every week. Water must be filtered for 10 minutes in every hour. Use a 32.768 kHz quartz oscillator.
- 1.6 Sketch the architecture of a system for monitoring the dose of ultraviolet light. Include a beeper that indicates when the maximum dose is exceeded. Suppose that sunlight can change every minute. Use an ultraviolet sensor to generate a signal approximately proportional to the square of light intensity.
- 1.7 What are the functions performed by an air-bag in a car? What kind of sensors and actuators are needed? Draft a block diagram of the complete system with the key functions outlined.
- 1.8 What is, in your opinion, a very small current and a very high voltage for a modern integrated circuit? How often is it necessary to replace a size 10 micro-battery used to continuously power a system that drains 2 μA from 1.5 V? Do a search on the Web to find possible answers.
- 1.9 Find on the Web the sensitivity in volts or amperes and the percentage accuracy of any kind of the following commercial sensors: pressure sensor, temperature sensor, flow sensor. Estimate the volume and the power requirements of each of them.
- 1.10 How many transistors are in one of the electronic devices in your pocket or purse? Estimate the volume that was required 20 years ago to obtain same function.
- 1.11 Find on the Web the number of transistors in the first microprocessor and the number of transistors in the latest generation of microprocessors. Estimate the growth rate per year.
- 1.12 Suppose you are to create a design team consisting of four people. What is your relevant proficiency? What kind of expertise would be a good match for you? Make a job description for each of the four people in the team.

- 1.13 Write a short note on what, in your opinion, is relevant to the learning process. Focus on the role of computer and simulation tools. What is, in your opinion, the difference between attending a lecture and reading a book?
- 1.14 Do a search on the Web and find two different CAD tools for analog design. Try to understand their features and advantages. What, in your opinion, makes them suitable (or not) for a learning process?
- 1.15 Use a flow diagram that mimics the sequence of actions of a CAD tool to derive the top-down steps that you suppose are necessary for designing the electronics circuitry for a washing machine.
- 1.16 Transistors are modeled with many parameters. Do a search on the Web and find a simple model used for bipolar transistors. Try to understand the meaning of the set of parameters and learn the role of the most relevant.
- 1.17 Do a search on the Web to find a description of the design flow of a digital system. Analyze the hierarchical organization of the flow. Be aware of simulation tools and their function in the design flow.
- 1.18 What is the role of packaging and assembly in microelectronic systems? Do a search on the Web to find the amount of power dissipated by a microprocessor and the type of package used for it.
- 1.19 Do the *ElvisLab* tour and understand the use and function of virtual instruments.