

1

Embryology, Innervation, Morphology, Structure, and Function of the Canine Intervertebral Disc

John F. Innes and James Melrose

Introduction

The intervertebral disc (IVD) is composed of a disparate collection of connective tissues of differing structure and function, and it is the dynamic interplay of these components in the composite IVD which endows it with its unique ability to withstand tensional stresses, to act as a viscoelastic hydrodynamic weight-bearing cushion, and to provide spinal flexibility [1]. While the cross-sectional area and angulation of IVDs vary with spinal level, all share common structural features. The outer region of the IVD, the annulus fibrosus (AF), is a collagen-rich tissue, while the central region of the IVD, the nucleus pulposus (NP), is rich in proteoglycans. The intervening region between the AF and NP is called the transitional zone (TZ). The areas of the IVD that interface with the adjacent vertebral bodies are called the cartilaginous end plates (CEPs); these are hyaline-like cartilaginous tissues containing cells of a rounded chondrocyte-like morphology.

Embryology of the IVD

During gastrulation, three somatic germ cell layers are initially laid down in the developing embryo: outer ectodermal, middle mesodermal, and inner endodermal layers [2–4]. A midline longitudinal rod-shaped column of the mesoderm, the notochord, subsequently develops from cell aggregates located between the ectoderm and endoderm and establishes cranial/caudal and ventral/dorsal axes in the developing embryo [2]. Ectoderm dorsal to the notochord gives rise to the neuroectoderm from which the neural tube develops. Adjacent mesodermal tissue develops into discrete tissue units, termed as the somites [5]. The somites consist of three tissue types: (1) the dermatome which gives rise to the dermis, (2) the myotome which gives rise to the axial musculature, and (3) the sclerotome from which vertebral structures arise. Cells of the sclerotome migrate medially and ventrally to form a continuous tube of mesenchymal cells (the perichordal sheath)

which surround the notochord. Increased proliferation of cells at regular lengths along the perichordal tube creates areas of low and high cell density from which the vertebrae and AF, TZ, and spinal ligaments develop [5]. Formation of the vertebral bodies results in segmentation of the notochord. Each notochordal segment persists in the central region of the developing IVD to give rise to the NP [3]. Thus, during embryonic disc development, cells of the AF are derived from the sclerotome, whereas the NP originates from the notochord [3]. In nonchondrodystrophoid breeds, notochordal cells persist into adulthood, whereas in chondrodystrophoid breeds they disappear within 2 years of birth. This correlates with an earlier onset of IVD degeneration in chondrodystrophoid breeds.

Innervation of the IVD

There are major neuroanatomical differences between the human and canine spines in terms of how far the spinal cord extends along the vertebral canal. In humans, the spinal cord extends as far as the second lumbar vertebra with nerves exiting the spinal cord descending inside the remaining lumbar and sacral vertebral segments to exit through their respective foramina. The spinal cord in dogs ends at approximately L6 with nerves that serve the IVDs descending through the last lumbar, sacral and coccygeal vertebral segments. The canine cervical IVDs are served by 8 pairs of nerves, the thoracic IVDs have 13 pairs, the lumbar IVDs have 7 pairs, and the coccygeal region contains 2 nerves per IVD.

The human lumbar IVD is innervated by several nerves. The sinuvertebral nerve (meningeal rami) innervates the posterior (i.e., dorsal) aspect of the disc and the posterior (dorsal) longitudinal ligament. Branches from the rami communicantes innervate the lateral aspects of the disc and the anterior (ventral) longitudinal ligament [6]. A structure similar to the sinuvertebral nerve is not apparent in the canine thoracolumbar spine and in contrast to the human IVD, sensory nerves are sparse in the outermost annular lamellae. However, the dorsal longitudinal ligament is innervated profusely [7]. The nerves in the outer AF communicate with caudal and cranial spinal levels two positions removed from the actual site of annular innervation,

which explains the referred pain reported at sites distant from damaged annular nerves.

Obvious postural differences in man and dogs and effects on IVD loading contribute to differences in the resolution of forces along the spine and the incidence and distribution of spinal neurological deficits of clinical relevance [8, 9]. The upright stance of humans results in axial spinal forces being transferred down the spinal column to the lumbar region and it is this region that has the highest incidence of IVD degeneration. Posterior lumbar IVD prolapse in man can lead to significant generation of sciatic pain and impairment in mobility; however, paralysis is rarely encountered. In the canine spine, the juncture of the immobile thoracic and mobile lumbar spine is the region that has the highest incidence of disc herniation. Furthermore, since the spinal cord extends to this level in dogs, compression of the spinal cord by extruded disc material can have a significant neurological impact [10–12]. IVD degenerative diseases are generally more common in the chondrodystrophoid breeds than nonchondrodystrophoid breeds and more prevalent in older than younger dogs [13, 14] (Figure 1.1). The clinical presentation of thoracolumbar disc herniation in dogs can be severe with profound paralysis of their pelvic limbs from the resulting spinal cord damage [15]. The thoracolumbar vertebral canal is almost entirely filled by the spinal cord, and there is very little extradural space, which explains why herniations in canine thoracolumbar IVDs are so debilitating [16].

IVD morphology, structure, and function

The immature nonchondrodystrophoid canine IVD has an extremely gelatinous NP that with age becomes progressively more fibrous and less hydrated with the decline in proteoglycan levels (Figure 1.1 A). IVDs of chondrodystrophoid canine breeds have a relatively fibrous NP (Figure 1.1 B). The NP is surrounded by well-defined collagenous annular lamellae (Figure 1.1 B). Calcification of the NP occurs in the chondrodystrophoid canine breeds but infrequently in nonchondrodystrophoid dogs (Figure 1.1 C).

The annular lamellae contain collagenous fibers of type I and II collagen, which comprise 40–60%

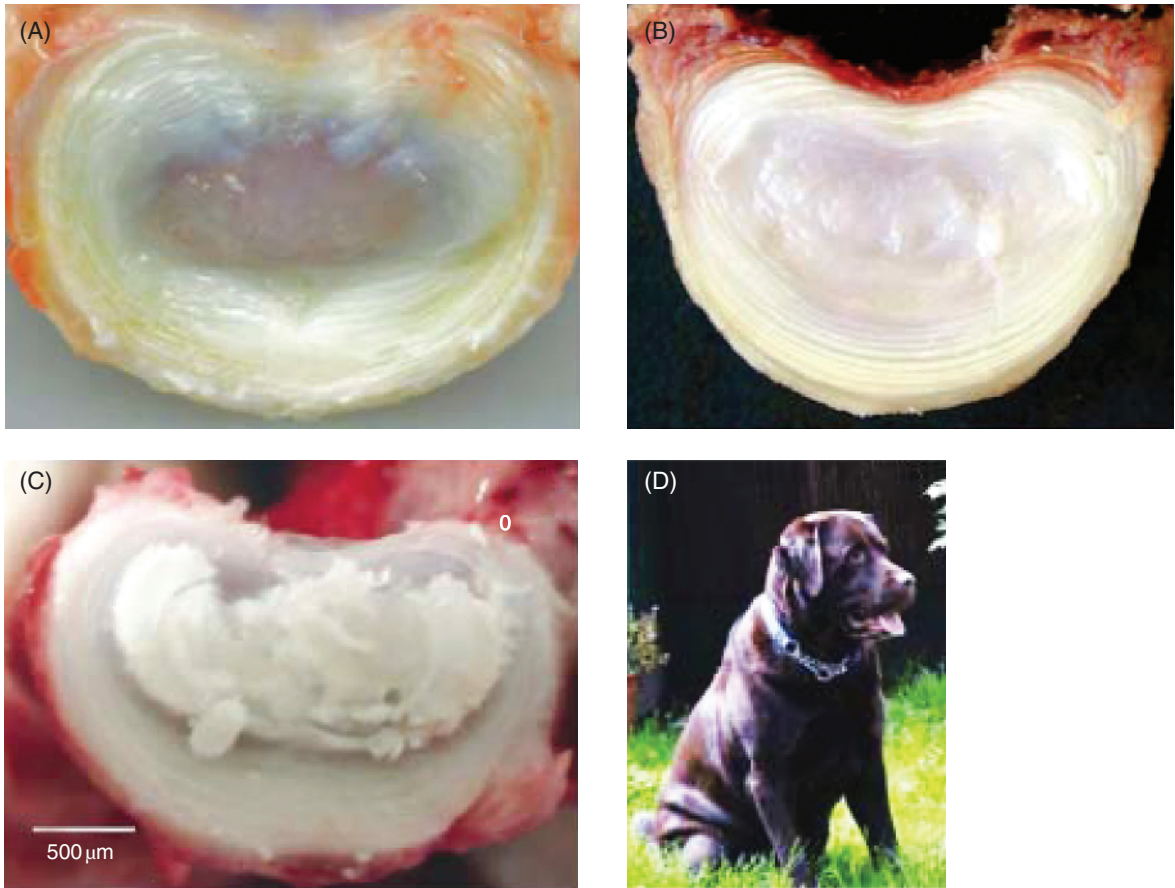

Figure 1.1 Composite figure depicting macroviews of horizontally bisected lumbar intervertebral discs demonstrating their characteristic morphology with the peripheral annular lamellae clearly evident and central nucleus pulposus. Discs typical of nonchondrodystrophic (A) and chondrodystrophic (B, C) canine breeds are shown. In plate (A), the nucleus pulposus is gelatinous, while in (B) the nucleus pulposus has a fibrous consistency typical of a chondrodystrophic breed (beagle). In plate (C), the entire nucleus pulposus has undergone calcification (Hansen type I). Plate (D) depicts an example of typical nonchondrodystrophic canine breed, labrador retriever. Labradors typically present with disc degeneration at ages of 5–12 years. Figures (A) and (C) supplied by courtesy of Dr PN. Bergknut, Faculty of Veterinary Medicine, Utrecht University.

of the dry weight of the outer annulus and 25–40% of the inner annulus. Type I and II collagens are radially distributed in opposing gradients from the disc periphery to the NP with the concentration of type I collagen greatest in the outer AF, while type II collagen predominates in the NP (Figure 1.2 A, B, D, and E). The tension-bearing properties of the AF are principally conveyed by type I collagen fiber bundles; however, the resistance to compression provided by the NP is provided by proteoglycans (aggrecan) and their associated hydration entrapped within a type II collagen network

(Figure 1.2C and F). Collagen fibers are virtually inextensible and their major role is in the provision of tensile strength. Elastin fibers located in intralamellar margins interconnect adjacent lamellae and return the fully extended collagen fibers to their preloaded dimensions. The elastin content of the IVD is small (1–2%) but nevertheless essential in the provision of elastic material properties [17]. Type I collagen fiber bundles insert firmly but imperceptibly with the CEPs and underlying vertebral bone to form anchorage points for the IVD to adjacent bony structures (Figures 1.2G–I).

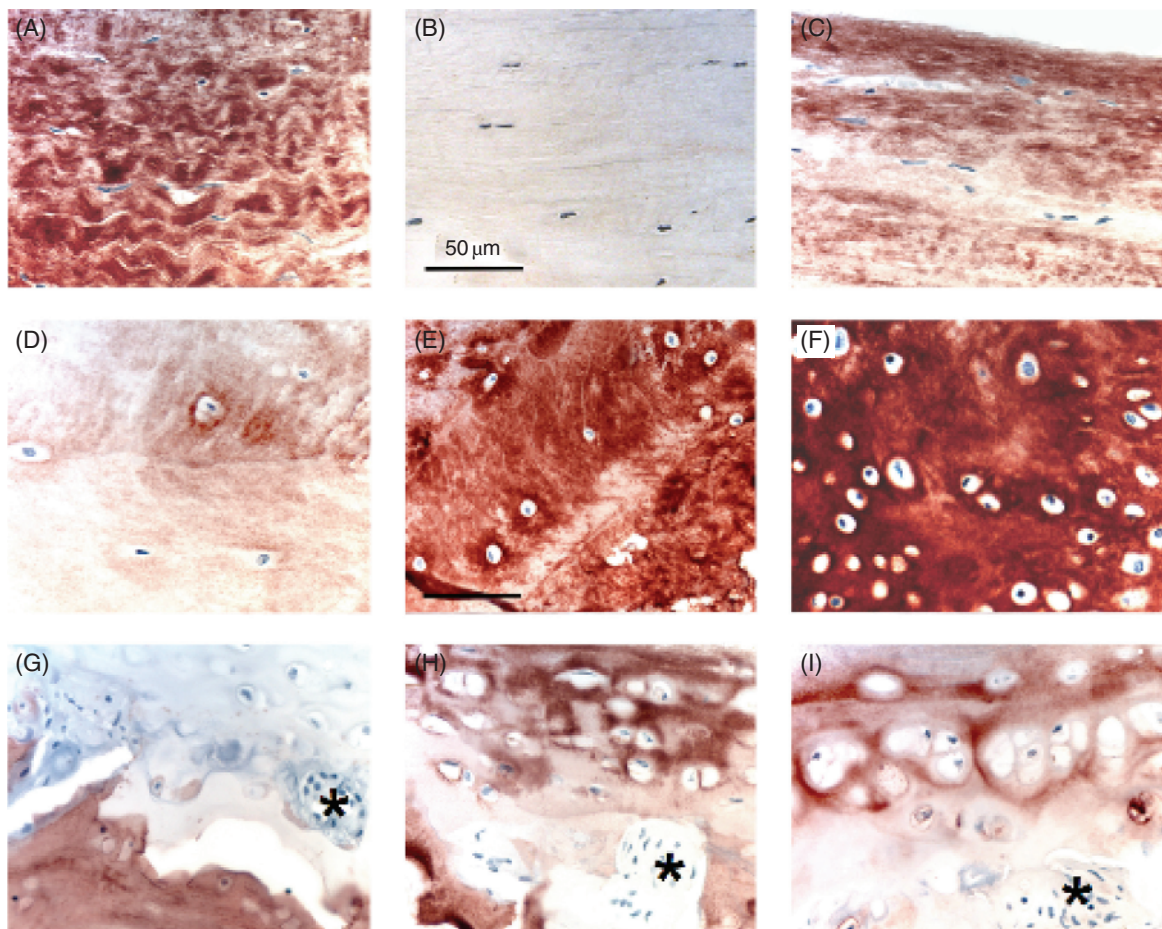

Figure 1.2 Composite figure depicting the immunolocalization of type I (A, D, G) and type II collagen (B, E, H) and the major space-filling and water-imbibing disc proteoglycan aggrecan (C, F, I) in the outer annulus fibrosus (A–C), inner annulus fibrosus/nucleus pulposus (D–F), and cartilaginous end plate (G–I). Plate (A) depicts strong localization of type I collagen displaying a crimp pattern in the outer annulus fibrosus. This is consistent with the hoop stresses generated within and tensional forces carried by this tissue. The outer annulus fibrosus is devoid of type II collagen (B) while it contains a sparse distribution of aggrecan (C). The characteristic elongated fibroblastic morphology of the annular cells is also evident (A–C). The inner annulus fibrosus/nucleus pulposus contains a little type I collagen (D) but is rich in type II collagen (E) and aggrecan (F). The cells in this region of the intervertebral disc display a characteristic rounded morphology (E–F). The cartilaginous end plate is a hyaline cartilage-like tissue that forms the interface of the intervertebral disc with the vertebral bodies (G–I). This tissue also contains cells of a rounded chondrocytic morphology surrounded by type II collagen (H) and aggrecan (I) but does not contain type I collagen (G), while the underlying vertebral bone is stained positively for type I collagen (G). The cartilaginous end plate has important roles to play in the nutrition of the disc cells with small blood vessels (*) clearly in evidence in the underlying vertebral vascular bed (G–I). The intervertebral discs shown are vertical midsagittal sections from an L1–L2 disc of a 2-year-old French bulldog, a typical chondrodystrophic canine breed.

The NP acts as a viscoelastic hydrodynamic cushion that counters compressive loading of the spine. Upon axial loading of the spine, compression of the NP results in load transference to the AF which is arranged in collagenous lamellar layers

with collagen fiber bundles arranged at a 50–60° angle relative to one another in adjacent lamellae (Figure 1.3). This results in bulging of the annular lamellae with the generation of hoop stresses that dissipate axial compressive forces.

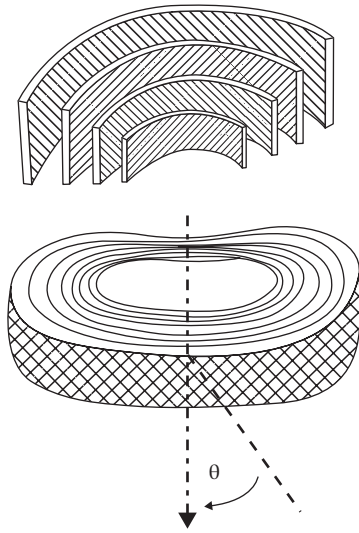

Figure 1.3 Schematic depiction of the lamellar structure of the annulus fibrosus in a partially exploded view and surrounding the central nucleus pulposus with the parallel arrays of collagen fiber bundles indicated oriented at 50–60° (θ) relative to collagen fiber bundles in adjacent lamellae in the transverse plane.

References

1. Bray JP, Burbidge HM. The canine intervertebral disk: part one: structure and function. *J Am Anim Hosp Assoc.* 1998 Jan–Feb;34(1):55–63.
2. Sinowatz F. Musculoskeletal system. In: Hyttel P SF, Veijlstad M, editors. *Essentials of domestic animal embryology* 1st edition. Edinburgh, London, NY, Oxford, Philadelphia, St. Louis, Sydney, Toronto: Saunders, Elsevier; 2010. pp. 286–316.
3. Risbud MV, Schaer TP, Shapiro IM. Toward an understanding of the role of notochordal cells in the adult intervertebral disc: from discord to accord. *Dev Dyn.* 2010 Aug;239(8):2141–8.
4. Smits P, Lefebvre V. Sox5 and Sox6 are required for notochord extracellular matrix sheath formation, notochord cell survival and development of the nucleus pulposus of intervertebral discs. *Development.* 2003 Mar;130(6):1135–48.
5. MacGeady TA QP, FitzPatrick ES. Muscular and skeletal systems. In: MacGeady TA QP, FitzPatrick ES, editors. *Veterinary Embryology.* Oxford: Blackwell Publishing; 2006. pp. 184–204.
6. Bogduk N, Tynan W, Wilson AS. The nerve supply to the human lumbar intervertebral discs. *J Anat.* 1981 Jan;132(Pt 1):39–56.
7. Forsythe WB, Ghoshal NG. Innervation of the canine thoracolumbar vertebral column. *Anat Rec.* 1984 Jan;208(1):57–63.
8. Verheijen J, Bouw J. Canine intervertebral disc disease: a review of etiologic and predisposing factors. *Vet Q.* 1982;4(3):125–34.
9. Miller JA, Schmatz C, Schultz AB. Lumbar disc degeneration: correlation with age, sex, and spine level in 600 autopsy specimens. *Spine (Phila Pa 1976).* 1988 Feb;13(2):173–8.
10. Gage E. Incidence of clinical disc disease in the dog. *J Am Anim Hosp Assoc.* 1975;135:135–8.
11. Goggin JE, Li AS, Franti CE. Canine intervertebral disk disease: characterization by age, sex, breed, and anatomic site of involvement. *Am J Vet Res.* 1970 Sep;31(9):1687–92.
12. Hansen HJ. A pathologic-anatomical interpretation of disc degeneration in dogs. *Acta Orthop Scand.* 1951;20(4):280–93.
13. Bray JP, Burbidge HM. The canine intervertebral disk. Part Two: Degenerative changes—nonchondrodystrophoid versus chondrodystrophoid disks. *J Am Anim Hosp Assoc.* 1998 Mar–Apr; 34(2):135–44.
14. Preister W. Canine intervertebral disc disease—occurrence by age, breed, and sex among 8,117 cases *Theriogenology.* 1976;6:293–303.
15. Hoerlein BF. Intervertebral disc protrusions in the dog. I. Incidence and pathological lesions. *Am J Vet Res.* 1953 Apr;14(51):260–9.
16. Ferreira AJ, Correia JH, Jaggy A. Thoracolumbar disc disease in 71 paraplegic dogs: influence of rate of onset and duration of clinical signs on treatment results. *J Small Anim Pract.* 2002 Apr;43(4):158–63.
17. Johnson EF, Caldwell RW, Berryman HE, Miller A, Chetty K. Elastic fibers in the annulus fibrosus of the dog intervertebral disc. *Acta Anat (Basel).* 1984;118(4):238–42.