

Chapter I

Radiant Heating

Heat is lost from the human body through radiation, convection, and evaporation. Radiation heat loss represents the transfer of energy by means of electromagnetic waves. The convection loss is the heat carried away by the passage of air over the skin and clothing. The evaporation loss is the heat used up in converting moisture on the surface of the skin into vapor.

Heat transfer, whether by convection or radiation, follows the same physical laws in the radiant heating system as in any other; that is, heat flows from the warmer to the cooler exposure at a rate directly proportional to the existing temperature difference.

The natural tendency of warmed air to rise makes it apparent that this induced air current movement is greater at the cooler floor and exterior walls of the average heated enclosure than at its ceiling. It is through absorption by these air currents that the radiant panel releases the convection component of its heat transfer into the room air.

The average body heat loss is approximately 400 Btu per hour; total radiation and convection account for approximately 300 to 320 Btu of it. Because this is obviously the major portion, the problem of providing comfort is principally concerned with establishing the proper balance between radiation and convection losses.

It is important to understand that bodily comfort is obtained in radiant heating by maintaining a proper balance between radiation and convection. Thus, if the air becomes cooler and accordingly the amount of heat given off from the body by convection *increases*, then the body can still adjust itself to a sense of comfort if the heat given off from the body by radiation is *decreased*. The amount given off from the body by radiation can be decreased by raising the temperature of the surrounding surfaces, such as the walls, floor, and ceiling. For comfort, the body demands that if the amount of heat given off by convection increases, the heat given off by radiation must decrease, and vice versa.

The principles involved in radiant heating exist in such commonplace sources of heat as the open fireplace, outdoor campfires, electric spot heaters, and similar devices. In each of these examples, no attempt is made to heat the air or enclosing surfaces surrounding the individual. In fact, the temperature of the air and surrounding

surfaces may be very low, but the radiant heat from the fireplace or campfire will still produce a sensation of comfort (or even discomfort from excess heat) to those persons within range. This situation can occur even though a conventional thermometer may indicate a temperature well below freezing. Radiant heat rays do not perceptibly heat the atmosphere through which they pass. They move from warm to colder surfaces where a portion of their heat is absorbed.

This chapter is primarily concerned with a description of radiant panel heating, which can be defined as a form of radiant heating in which large surfaces are used to radiate heat at relatively low temperatures. The principal emphasis will be on hydronic and electric radiant floor heating.

Types of Radiant Panel Heating Systems

Radiant panel heating systems use water-filled tubing or electric heating mats or rolls installed in the floors, walls, and ceilings to distribute the heat. Radiant floor heating is by far the most popular installation method in residential and light-commercial construction.

Note

The word *panel* is used to indicate a complete system of tubing loops in a single room or space in a structure. It may also be used to indicate a premanufactured radiant floor heating panel.

Floor Panel Systems

Floor panels are usually easier to install than either ceiling or wall panels. Using floor panels is the most effective method of eliminating cold floors in slab construction. Another advantage of heating with floor panels is that much of the radiated heat is delivered to the lower portions of the walls. The principal disadvantage of using floor panels is that furniture and other objects block portions of the heat emission.

Floor panels are recommended for living or working areas constructed directly on the ground, particularly one-story structures. Partial ceiling or wall treatment may be used as a supplement wherever large glass or door exposures are encountered. A typical floor installation is shown in Figure 1-1.

Ceiling Panel Systems

The advantage of a ceiling panel is that its heat emissions are not affected by drapes or furniture. As a result, the entire ceiling area can be used as a heating panel. Ceiling panels are recommended for rooms or space with 7-foot ceilings or higher. A ceiling panel should never be installed in a room with a low ceiling (under 7 feet) because it may produce an undesirable heating effect on the head.

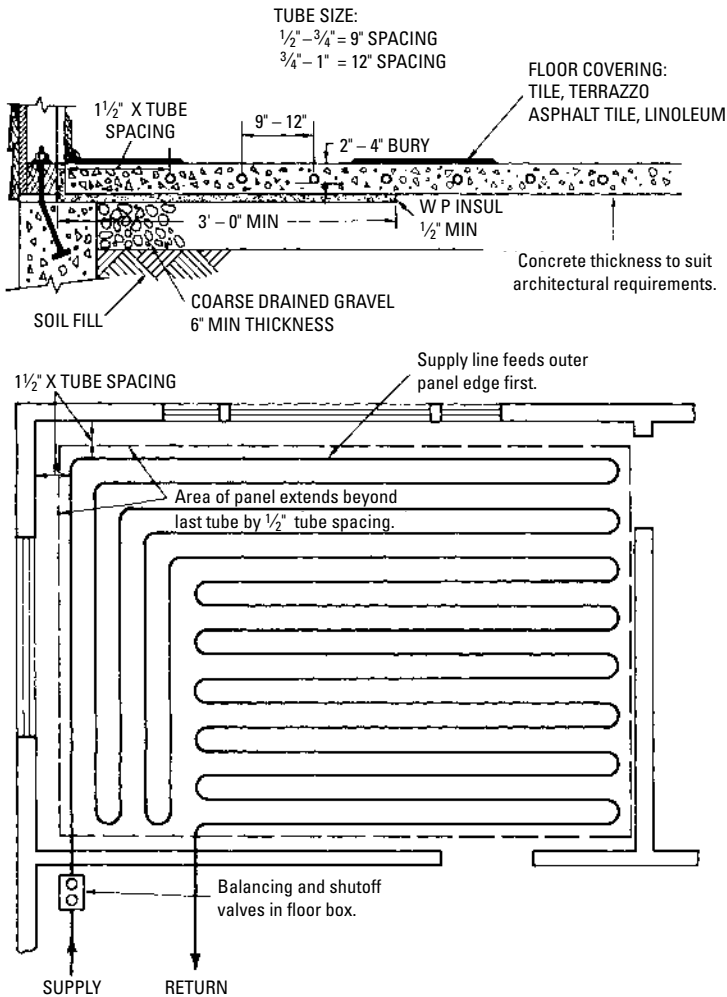

Figure I-1 Diagram of a typical radiant floor heating installation.

In multiple-story construction, the use of ceiling panels appears to be more desirable from both the standpoint of physical comfort and overall economy. The designed utilization of the upward heat transmission from ceiling panels to the floor of the area immediately above will generally produce moderately tempered floors. Supplementing this with automatically controlled ceiling panels

4 Chapter I

will result in a very efficient radiant heating system. Except directly below roofs or other unheated areas, this design eliminates the need for the intermediate floor insulation sometimes used to restrict the heat transfer from a ceiling panel exclusively to the area immediately below. It must be remembered, however, that when intermediate floor insulations are omitted, the space above a heated ceiling will not be entirely independent with respect to temperature control but will necessarily be influenced by the conditions in the space below. A typical ceiling installation is shown in Figure 1-2.

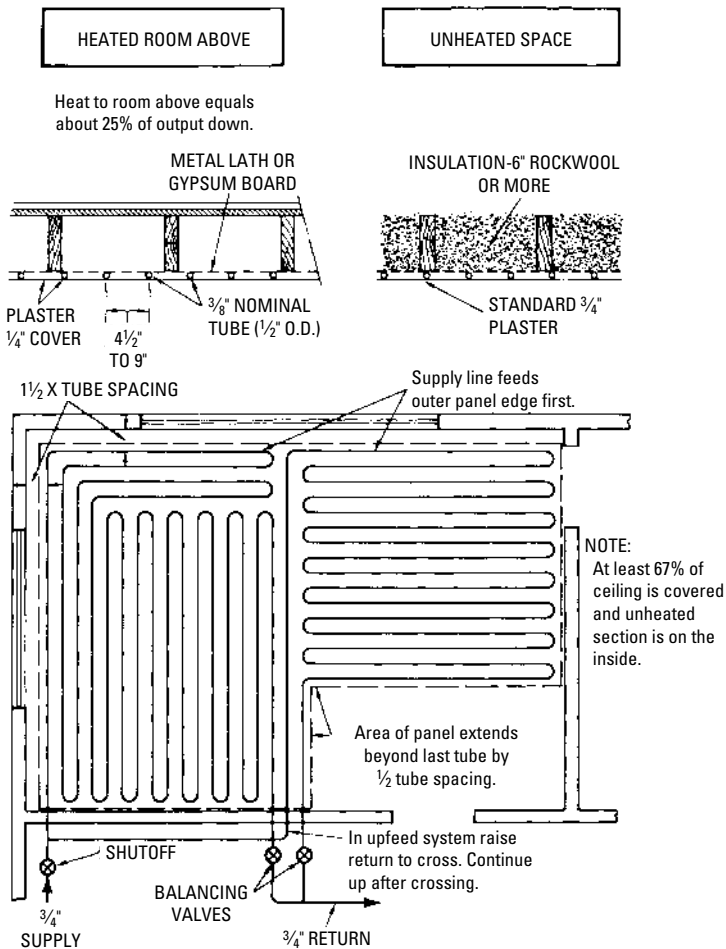

Figure 1-2 Diagram of a typical radiant ceiling heating panel.

Apartment buildings and many office and commercial structures should find the ceiling panel method of radiant heating most desirable. In offices and stores, the highly variable and changeable furnishings, fixtures, and equipment favor the construction of ceiling panels, to say nothing of the advantage of being able to make as many partition alterations as desired without affecting the efficiency of the heating system.

Wall Panel Systems

Walls are not often used for radiant heating because large sections of the wall area are often interrupted by windows and doors. Furthermore, the heat radiation from heating coils placed in the lower sections of a wall will probably be blocked by furniture. As a result, a radiant wall installation is generally used to supplement ceiling or floor systems, not as a sole source of heat.

Wall heating coils are commonly used as supplementary heating in bathrooms and in rooms in which there are a number of large picture windows. In the latter case, the heating coils are installed in the walls opposite the windows. Wall heating coils will probably not be necessary if the room has good southern exposure. A typical wall installation is shown in Figure 1-3.

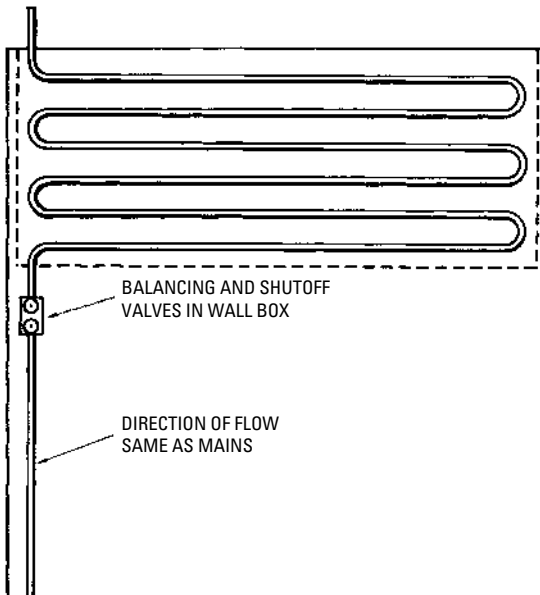

Figure 1-3 Typical wall installation. Panel is installed on wall as high as possible.

Hydronic Radiant Floor Heating

Hydronic radiant floor systems heat water in a boiler, heat pump, or water heater and force it through tubing arranged in a pattern of loops located beneath the floor surface. These systems can be classified as being either wet installations or dry installations depending on how the tubing is installed.

In wet installations, the tubing is commonly embedded in a concrete foundation slab or attached to a subfloor and covered with a lightweight concrete slab. Dry installations are so called because the tubing is not embedded in concrete.

System Components

The principal components of a typical hydronic radiant floor heating system can be divided into the following categories:

1. Boilers, water heaters, and heat pumps
2. Tubing and fittings
3. Valves and related controls
4. Circulator
5. Expansion tank
6. Air separator
7. Heat exchanger
8. Thermostat

Boilers, Water Heaters, and Heat Pumps

The boilers used in hot-water radiant heating systems are the same types of heating appliances as those used in hydronic heating systems. Information about the installation, maintenance, service, and repair of hydronic boilers is contained in Chapter 15 of Volume 1.

Gas-fired boilers are the most widely used heat source in hydronic radiant heating systems. Oil-fired boilers are second in popularity and are used most commonly in the northern United States and Canada. Coal-fired boilers are still found in some hydronic radiant heating systems, but their use has steadily declined over the years.

Note

Hydronic radiant floor heating systems operate in an 85–140°F (29–60°C) temperature range. This is much lower than the 130–160°F (54–71°C) temperature operating range required in other hydronic systems. As a result, the boilers used in floor systems

operate at lower boiler temperatures, which results in a much longer service life for the appliance.

The electric boilers used in hydronic radiant floor systems are competitive with other fuels in those areas where electricity costs are low. Their principal advantage is that they are compact appliances that can be installed where space is limited.

Radiant floor systems can also be heated with a geothermal heat pump. In climates where the heating and cooling loads are equal or almost equal in size, a geothermal heat pump will be very cost effective.

Most standard water heaters produce a maximum of 40,000 to 50,000 Btu/h. This is sufficient Btu input to heat a small house or to separately heat a room addition, but it cannot provide the heat required for medium to large houses. As a result, some HVAC manufacturers have developed high-Btu-output dedicated water heaters for radiant heating systems. These water heaters are designed specifically as single heat sources for both the domestic hot water and the space-heating requirements. As is the case with boilers used in hydronic radiant heating systems, they operate in conjunction with a circulating pump and an expansion tank. See Chapter 4 (“Water Heaters”) for additional information about combination water heaters.

Tubing and Fittings

The tubing in a radiant heating system is divided into the supply and return lines. The *supply line* extends from the discharge opening of a boiler to the manifold. It carries the heated fluid to the loops (circuits) in the floors, walls, or ceilings. A *return line* extends from the return side of a manifold to the boiler. It carries the water from the heating panels back to the boiler where it is reheated.

Hydronic radiant floor heating systems use copper, plastic (PEX or polybutylene tubing), or synthetic-rubber tubing to form the loops. Because of space limitations, only the two most commonly used types are described in this chapter: copper tubing and PEX (plastic) tubing. Information about the other types of tubing used in hydronic heating systems can be found in Chapter 8 (“Pipes, Pipe Fittings, and Piping Details”) of Volume 2.

Loops or Circuits

The words *loop* and *circuit* are synonyms for the length of tubing within a zone. Sometimes both are used in the same technical publication. At other times, one or the other is used exclusively. Many loops or circuits of the same length will form a zone. Circuits also refer to the electrical circuit required to operate the heating system.

Copper Tubing

In most modern radiant floor heating systems, the water is circulated through copper or cross-linked polyethylene (PEX) tubing (see Figure 1-4). The metal coils used in hydronic radiant heating systems commonly are made of copper tubing (both the hard and soft varieties). Steel and wrought-iron pipe also have been used in hydronic floor heating systems, but it is rare to find them in modern residential radiant floor heating systems.

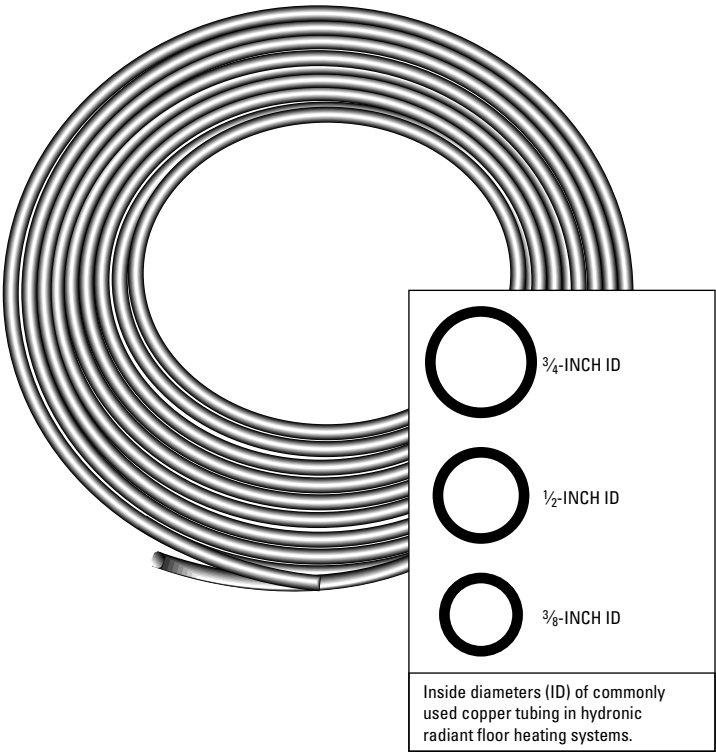

Figure 1-4 Copper tubing.

The soft tempered Type L copper tubing is recommended for hydronic radiant heating panels. Because of the relative ease with which soft copper tubes can be bent and shaped, they are especially well adapted for making connections around furnaces, boilers, oil-burning equipment, and other obstructions. This high workability characteristic of copper tubing also results in reduced installation

time and lower installation costs. Copper tubing is produced in diameters ranging from $\frac{1}{8}$ inch to 10 inches and in a variety of different wall thicknesses. Both copper and brass fittings are available. Hydronic heating systems use small tube sizes joined by soldering.

The size of the pipes or tubing used in these systems depends on the flow rate of the water and the friction loss in the tubing. The *flow rate* of the water is measured in gallons per minute (gpm), and constant *friction loss* is expressed in thousandths of an inch for each foot of pipe length. For a description of the various types of tubing used in hydronic heating systems, see the appropriate sections of Chapter 8 (“Pipes, Pipe Fittings, and Piping Details”) in Volume 2.

Most of the fittings used in hydronic radiant heating systems are typical plumbing fittings. They include couplings (standard, slip, and reducing couplings), elbows (both 45° and 90° elbows), male and female adapters, unions, and tees (full size and reducing tees) (see Figure 1-5).

Three special fittings used in hydronic radiant heating systems are the brass adapters, the brass couplings, and the repair couplings. A *brass adapter* is a fitting used to join the end of a length of $\frac{3}{4}$ -inch diameter copper tubing to the end of a length of plastic polyethylene tubing. A *brass coupling*, on the other hand, is a fitting used to join two pieces of plastic heat exchanger tubing. A *repair coupling* is a brass fitting enclosed in clear vinyl protective sheath to prevent concrete from corroding the metal fitting. The fitting is strengthened by double-clamping it with stainless steel hose clamps.

A decoiler bending device or jig should be used to bend metal tubing into the desired coil pattern. Only soft copper tubing can be easily bent by hand. It is recommended that a tube bender of this type be made for each of the different center-to-center spacing needed for the various panel coils in the installation.

Soft copper tubing is commonly available in coil lengths of 40 feet, 60 feet, and 100 feet. When the tubing is uncoiled, it should be straightened in the trough of a straightener jig. For convenience of handling, the straightener should not be more than 10 feet long.

Note

Most copper tubing leaks will occur at bends or U-turns in the floor loops. These leaks are caused by water or fluids under high pressure flowing through the weakened sections of tubing. The weakened metal is commonly caused by improper bending techniques.

Whenever possible, continuous lengths of tubing should be used with as few fitting connections as possible. Coils of 60 feet or 100 feet

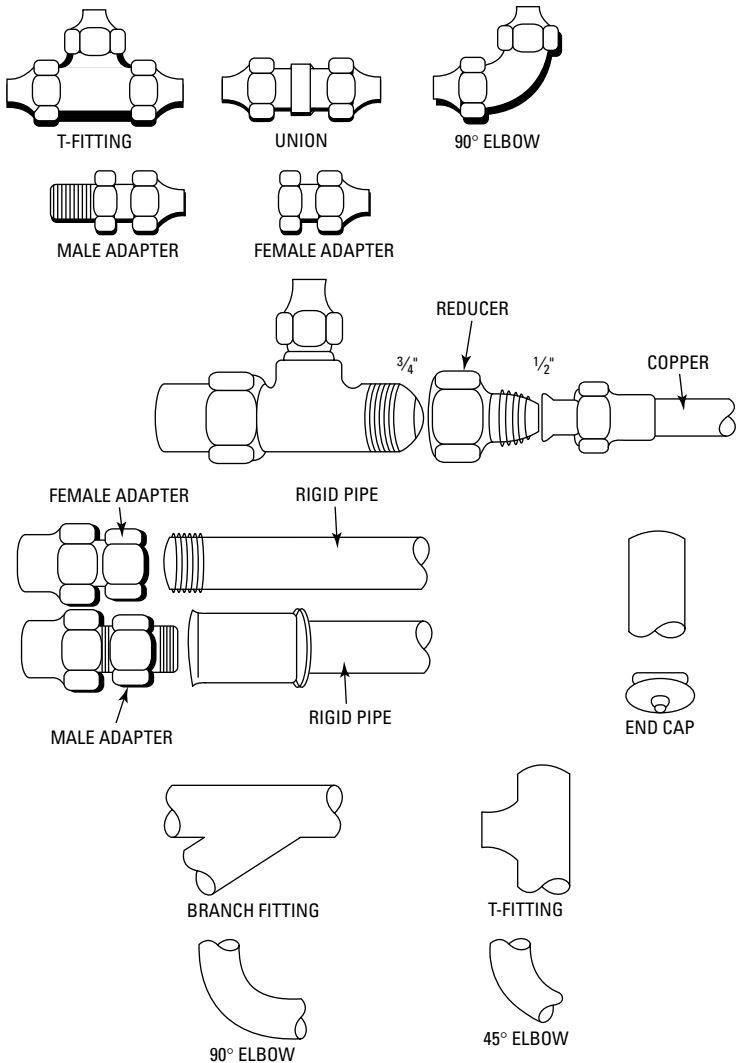

Figure I-5 Some examples of copper tubing fittings.

are best for this purpose and are generally preferred for floor panels. The spacing between the tubing should be uniform and restricted to 12 inches or less. Use soldered joints to make connections between sections of tubing or pipe.

Cross-Linked Polyethylene (PEX) Tubing

Cross-linked polyethylene (PEX) tubing is commonly used indoors in hydronic radiant heating panels or outdoors embedded beneath the surface of driveways, sidewalks, and patios to melt snow and ice. It is made of a high-density polyethylene plastic that has been subjected to a cross-linking process (see Figures 1-6, 1-7, and 1-8). It is flexible, durable, and easy to install. There are two types of PEX tubing:

- Oxygen barrier tubing
- Nonbarrier tubing

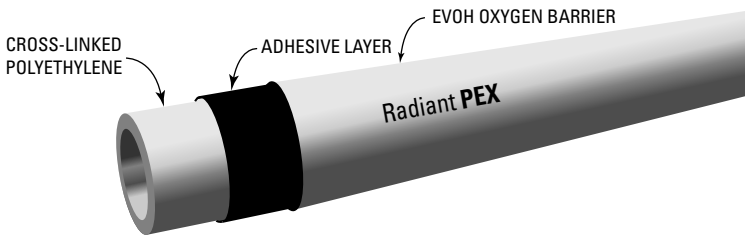

Figure 1-6 PEX tubing. (Courtesy Watts Radiant, Inc.)

Oxygen barrier tubing (BPEX) is treated with an oxygen barrier coating to prevent oxygen from passing through the tubing wall and contaminating the water in the system. It is designed specifically to prevent corrosion to any ferrous fittings or valves in the piping system. BPEX tubing is recommended for use in a hydronic radiant heating system.

Nonbarrier tubing should be used in a hydronic radiant heating system only if it can be isolated from the ferrous components by a corrosion-resistant heat exchanger, or if only corrosion-resistant system components (boiler, valves, and fittings) are used.

PEX tubing is easy to install. Its flexibility allows the installer to bend it around obstructions and into narrow spaces. A rigid plastic cutter tool, or a copper tubing cutter equipped with a plastic cutting wheel, should be used to cut and install PEX tubing. Both tools produce a square cut without burrs.

PEX tubing can be returned to its original shape after accidental crimping or kinking by heating it to about 250–275°F. This attribute of PEX tubing makes it possible to perform field repairs without removing the damaged tubing section. This is not the case with polybutylene tubing, which is not cross-linked. Synthetic rubber tubing

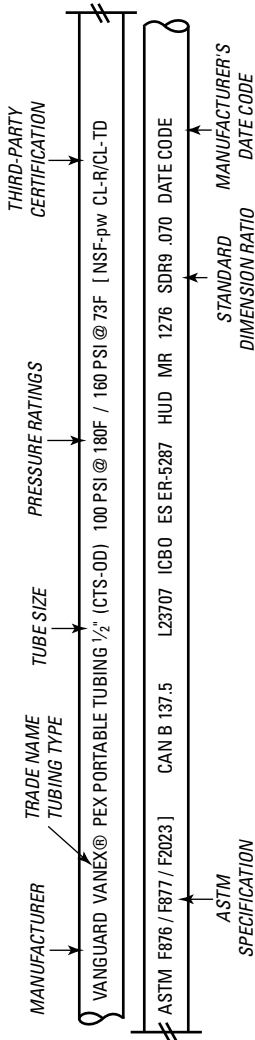
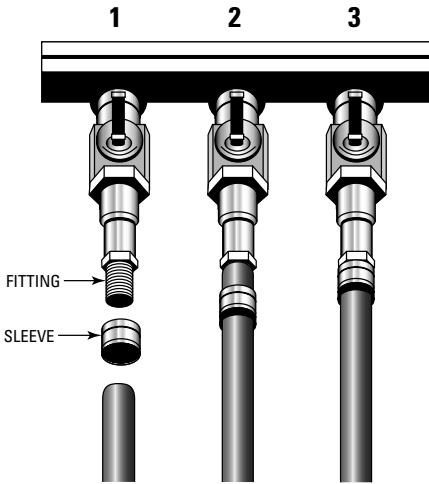
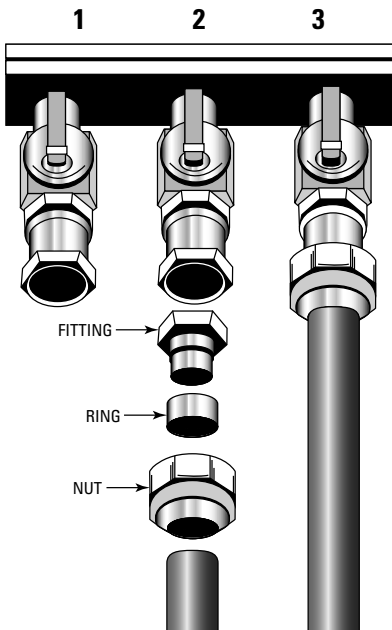

Figure I-7 PEX tubing markings. (Courtesy Vanguard Piping Systems, Inc.)



Crimping Fittings

1. Expand the end of the PEX tubing with the expansion tool provided by the PEX tube manufacturer.
2. Insert the brass fitting into the end of the expanded PEX tube.
3. Use the expansion tool to pull the brass sleeve back over the PEX tube and fitting for a tight connection.



Compression Fitting

1. Slide the locking nut and split compression ring up the tubing.
2. Insert the tubing onto the compression fitting.
3. Tighten the nut onto the compression fitting snugly.
4. Re-tighten the fittings after the heat has been turned on and the hot water has circulated through the tubing.

Figure I-8 PEX tubing fittings.

(Courtesy Watts Radiant, Inc.)

is also not cross-linked, but its material composition and its flexibility make it very resistant to crimping or kinking damage.

Manifolds

A *manifold* is a device used to connect multiple tubing lines to a single supply or return line in a hydronic radiant floor heating system (see Figures 1-9 and 1-10). Each heating system has at least two

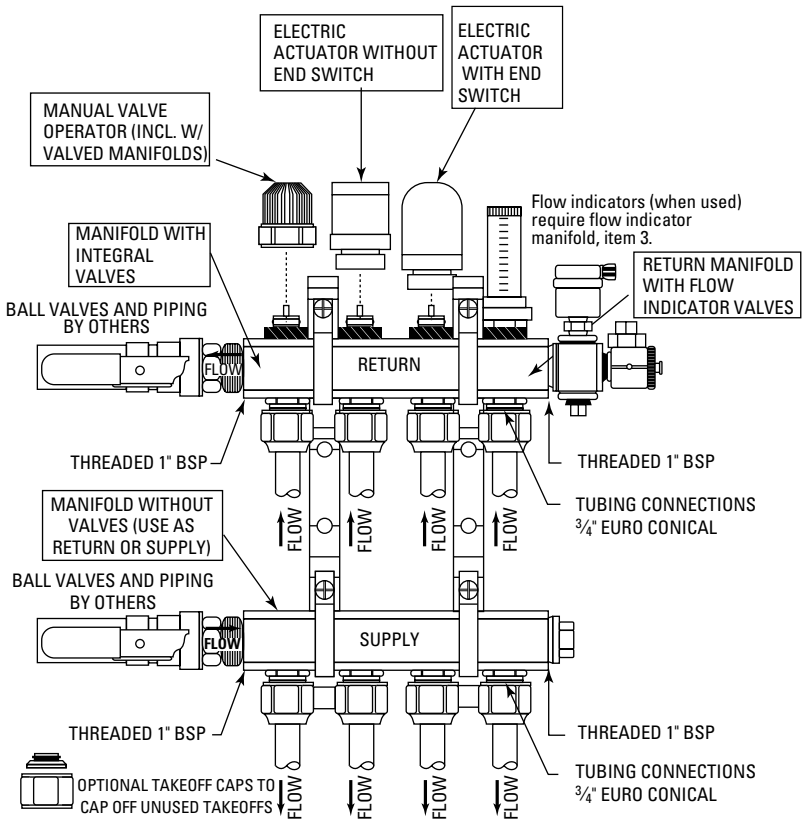

Manifolds with integral valves should be used as return manifolds unless flow indicators are desired. If both flow indication and electric valve actuators are needed, use manifold with flow indicator valves on their turn and manifold with integral valves on the supply. Apply any desired combination of 2-wire and 4-wire electric actuators.

Figure 1-9 Weil-McLain hydronic radiant heating manifold.

(Courtesy Weil-McLain)

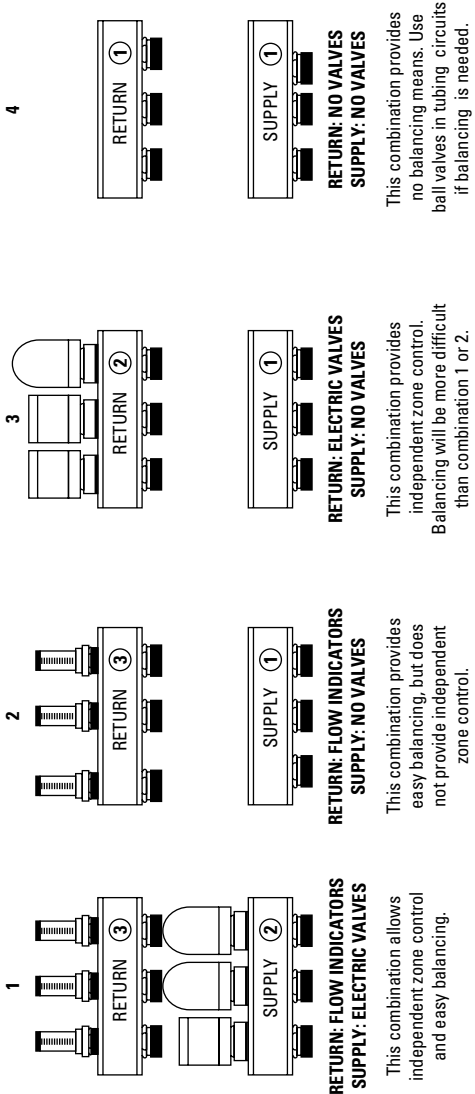

4

3

2

1

RETURN: NO VALVES
SUPPLY: NO VALVES

This combination provides no balancing means. Use ball valves in tubing circuits if balancing is needed.

RETURN: ELECTRIC VALVES
SUPPLY: NO VALVES

This combination provides independent zone control. Balancing will be more difficult than combination 1 or 2.

RETURN: FLOW INDICATORS
SUPPLY: NO VALVES

This combination provides easy balancing, but does not provide independent zone control.

RETURN: FLOW INDICATORS
SUPPLY: ELECTRIC VALVES

This combination allows independent zone control and easy balancing.

Figure I-10 Manifold combinations. (Courtesy Weil-McLain)

types of manifolds: a supply manifold and a return manifold. A supply manifold receives water from the heating appliance (that is, the boiler, water heater, or heat pump) through a single supply pipe and then distributes it through a number of different tubing lines to the room or space being heated (see Figure 1-11). A return manifold provides the opposite function. It receives the return water from the room or space through as many tubing lines and sends it back to the boiler by a single return pipe. A supply manifold and a return manifold are sometimes referred to jointly as a *manifold station*.

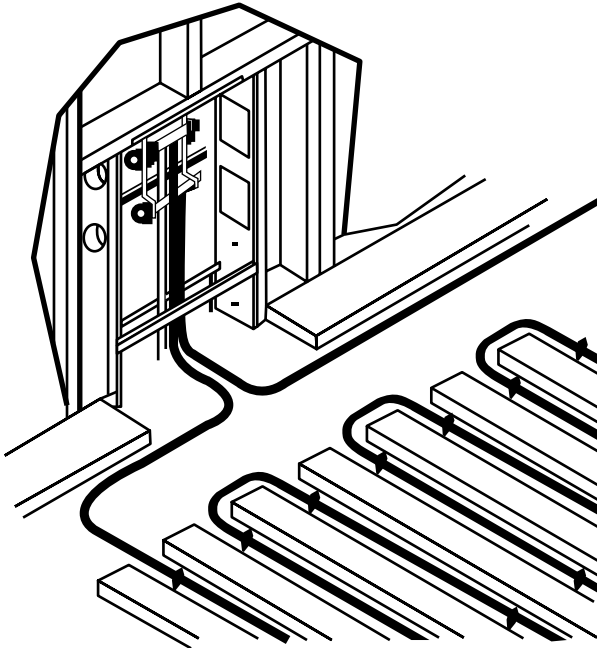

Figure I-11 Typical manifold location.

Preassembled manifolds are available from manufacturers for installation in most types of heating systems. Customized manifolds can also be ordered, but they are more expensive than the standard, preassembled types.

A *supply manifold*, when operating in conjunction with zone valves, can be used to control the hot water flow to the distribution lines in the radiant heating system. The zone valves, which are usually ball valves, can be manually adjusted or automatically opened

and closed with a zone valve actuator. Some zone valves are designed as fully open or fully closed valves. Others are operated by a modulating actuator that can adjust the opening to the heat required by the zoned space.

A supply manifold with zoning capabilities is sometimes called a *zone manifold* or *distribution manifold*. In addition to zone valves, these manifolds also can be ordered to include supply and return water sensors, the circulator, and a control panel with indoor and outdoor sensors.

Depending on the heating system requirements, a manifold may also include inline thermometers or a temperature gauge to measure the temperature of the water flowing through the tubing; check valves or isolation valves to isolate the manifold so that it can be serviced or repaired; drain valves to remove water from the manifold; an air vent to purge air from the system; and pump flanges (for the circulator) plus all the required plumbing connections and hardware.

Manifold balancing valves regulate each zone (loop) to ensure efficient heat distribution and eliminate those annoying cold and hot spots on the floor. These valves can be adjusted to deliver the design flow rate of water in gallons per minute (gpm). Some manifolds are designed to electronically read the flow and temperature of the water in individual tubing loops. This function results in rapid and accurate data feedback for balancing. It also makes troubleshooting problems easier.

Manifolds are available for mounting on walls or installation in concrete slabs. The latter type, sometimes called a *slab manifold*, is made of copper and is available with up to six supply and six return loop connections. Slab manifolds also should be equipped with a pressure-testing feature so that they can be tested for leaks before the slab is poured.

Slab manifolds are installed with a box or form that shields the device from the concrete when it is poured. All connections remain below the level of the floor except for the tops of the supply and return tubing.

Valves and Related Control Devices

Valves and similar control devices are used for a variety of different purposes in a hydronic radiant floor heating system. Some are used as high-limit controls to prevent excessively hot water from flowing through the floor loops. Some are used to isolate system components, such as the circulating pump, so that it can be serviced or removed without having to shut down the entire system. Others are used to regulate the pressure or temperature of the water, to reduce

the pressure of the water before it enters the boiler, or to regulate the flow of water.

Many of the different types of valves and control devices used in hydraulic radiant floor heating systems are listed in the sidebar. A brief description of the more commonly used ones is provided in this section. For a fuller, more detailed description of their operation, maintenance, service, and repair, read the appropriate sections of Chapter 9 (“Valves and Valve Installation”) of Volume 2. Not all the valves listed in the sidebar or the ones described in this chapter will necessarily be used in the same heating system. The valves chosen will fit the requirements of a specific application (see Figures 1-12, 1-13, and 1-14).

Hydraulic Heating System Valves and Related Control Devices

- Air vent
- Aquastat
- Backflow preventers
- Ball valves
- Boiler drain valve
- Check valves
- Feed water pressure regulator
- Flow control valve
- Gate valve
- Globe valve
- Isolation valve
- Mixing valve
- Motorized zone valve
- Pressure-reducing valve
- Pressure relief valve
- Purge and balancing valves
- Solenoid valve

Air Vent

An air vent is a device used to manually or automatically expel air from a closed hydronic heating system. An automatic air vent valve provides automatic and continuous venting of air from the system. The function of both types is to prevent air from collecting in the piping loops.

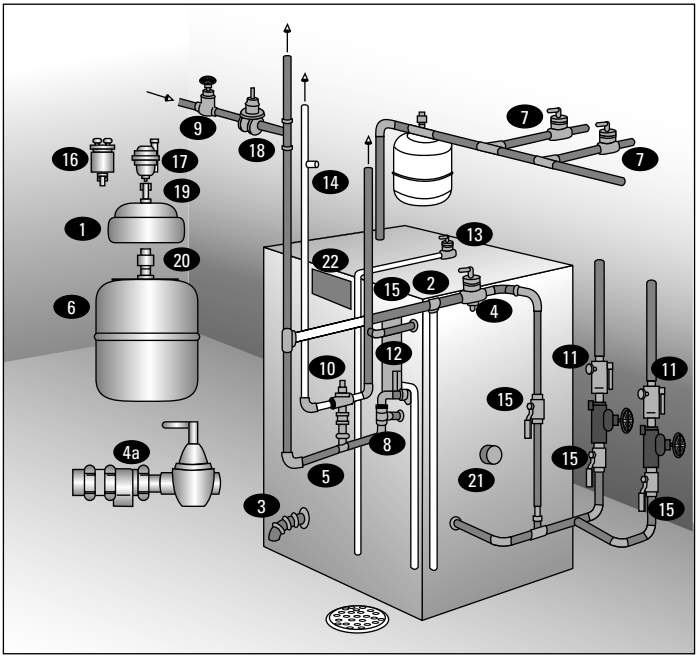

- | | |
|--|--|
| <ol style="list-style-type: none"> 1. Air scoop. 2. Backflow preventer. 3. Boiler drain valve. 4. Boiler fill valve. 4a. Combination backflow preventer and boiler fill valve. 5. Bronze check valve. 6. Expansion tank. 7. Flow check valves. 8. Flow control valve. 9. Gate or globe valve. 10. Mixing valve. | <ol style="list-style-type: none"> 11. Purge valve. 12. Pressure relief valve. 13. Hot water safety relief valve. 14. Test plug. 15. Ball valve. 16. Automatic float vent valve. 17. Float vent. 18. Water pressure reducing valve. 19. Service check valve. 20. Combination temperature and pressure gauge. 21. Boiler energy saver. |
|--|--|

Figure 1-12 Typical locations of valves and related control devices in a hydronic heating system. (Courtesy Watts Regulator Co.)

Aquastat

An *aquastat* is a control device consisting of a sensing bulb, a diaphragm, and a switch (see Figure 1-14). As the temperature surrounding the sensing bulb increases, the gas inside the bulb expands and flows into the diaphragm. This action causes the diaphragm to expand and activate the switch controlling the connected device. When temperatures exceed the high-limit setting on

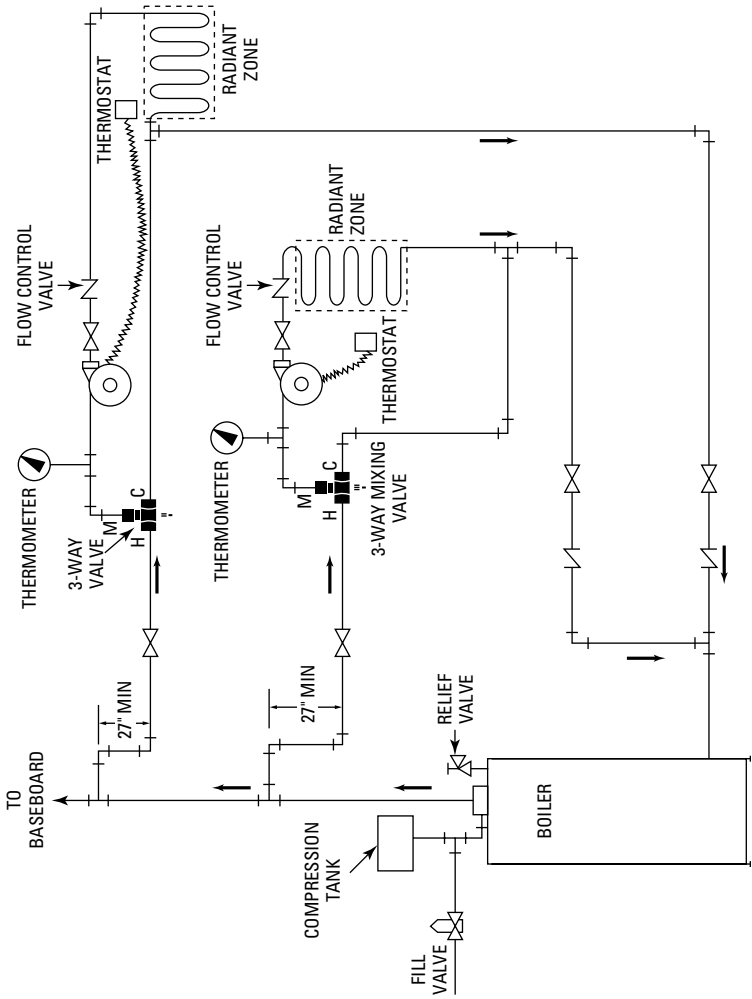
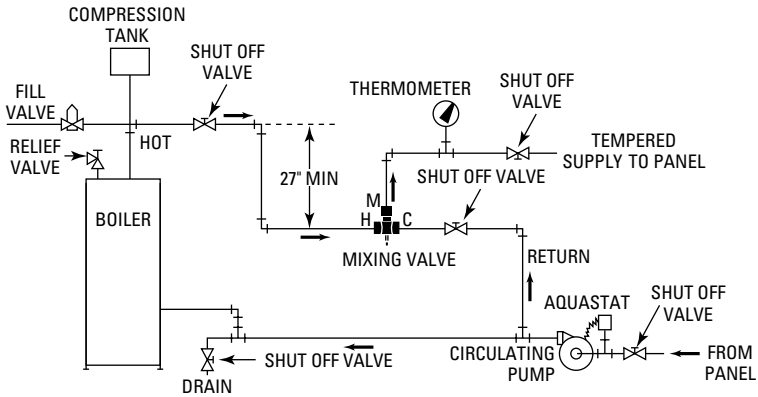

Figure I-13 Piping diagram of a zoned radiant heating system supplying hot water to both floor panels and baseboards.



Note: Circulating pumps, illustrated in the above applications, circulate tempered water through the system. The aquastat shuts the circulating pump off if the tempered water exceeds the temperature set point, which is normally $\pm 5^{\circ}\text{F}$ ($\pm 2^{\circ}\text{C}$) of the tempering valve discharge.

Figure I-14 Piping diagram of a radiant heating system with circulator controlled by aquastat.

the aquastat, it shuts off the circulator or circulators until the problem can be corrected.

The switching contacts of some aquastats can be manually adjusted for temperature settings. In other systems, the switching contacts of an aquastat may be preset at a predetermined temperature setting.

Backflow Preventer

A *backflow preventer* is a valve used to prevent the mixing of boiler hot water with domestic (potable) water (see Figure 1-15). Most systems use an inline backflow preventer. It must be installed with the arrow on the side of the valve facing the direction of water flow. Sometimes a backflow preventer and boiler fill valve are combined in the same unit.

Ball Valve, Gate, and Globe Valves

A *ball valve* can be used to isolate components or lines, or to regulate flow. A *gate valve* is often used to isolate components for service, repair, or replacement. They are not designed to regulate the flow of water. A *globe valve* is used to regulate the flow of water in a radiant heating system.

Note

Use a fully closing ball or gate valve on the supply and return line so that the manifold can be isolated and serviced without interrupting the pressure in the rest of the system.

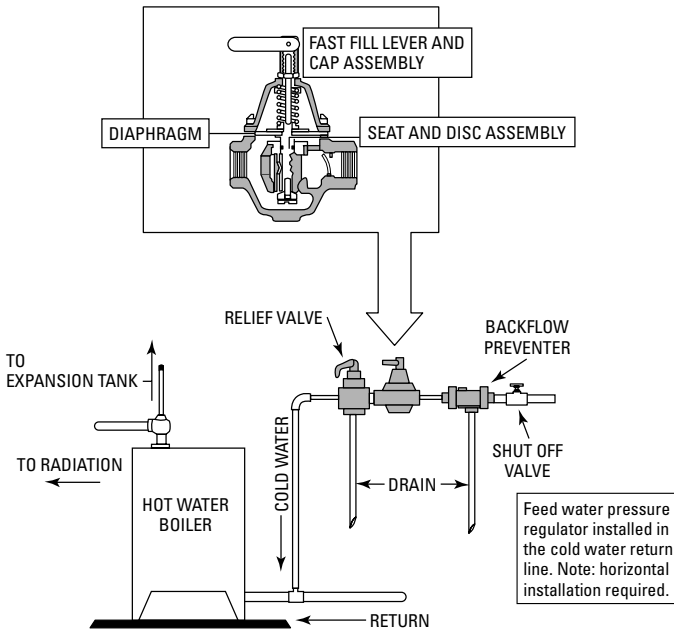

Figure I-15 Feed water pressure regulator. (Courtesy Watts Regulator Co.)

Boiler Drain Valve

A *boiler drain valve* is a quarter-turn ball valve used to drain water from a boiler. As shown in Figure 1-12, it is located near the bottom of the boiler close to a floor drain.

Check Valves

A *check valve* (also called a shutoff valve) is used to ensure that water is flowing in the correct direction by providing positive shut-off to the flow. Typical locations of check (shutoff) valves are shown in Figures 1-12, 1-13, and 1-14.

A *swing check valve* is designed to prevent the backflow of water. A *flow-control valve* is a check valve used to prevent circulation of the hot water through the heating system when the thermostat has not called for circulation. The flow-control check valve must be used when the radiant panels are located below the boiler.

Note

Flow-control valves should not be used when the radiant floor panel is below the level of the boiler.

Another type of check valve used in a radiant floor heating system is the *isolation valve* (also sometimes called a *service valve*).

The isolation valve is used to isolate a hydronic system component for servicing and/or removal so that it can be repaired or replaced. Isolating the component eliminates the need to drain and refill the system with water.

Caution

Reduce the system pressure to a safe level before attempting to remove system components.

Caution

An isolation valve is not designed to isolate a pressure (safety) relief valve or other safety or flow-sensitive components.

Feed Water Pressure Regulators

A feed water pressure regulator is used to fill both the boiler and system piping (including the floor panel loops) with water. A typical location of a feed water pressure regulator in the cold-water return line is illustrated in Figure 1-15. These valves also maintain the water pressure at the required level in the system at all times. If a leak should occur in the system, the feed water pressure regulator is designed to provide the required amount of makeup water. Using the feed water pressure regulator speeds filling and purging of air from the piping during the initial fill procedure.

Disconnect Switch

Two principal types of on-off switches are used to open or close an electrical circuit: the disconnect switch and the thermostat (see *Thermostat* in this section).

The *disconnect switch* is a manually operated on-off switch used to shut down the entire heating system when a problem is beginning to develop. When the switch is in the off position, the circuit opens and the electricity operating the boiler, heat pump, or water heater is shut off. When it is in the on position, the circuit closes (that is, completes itself) and electricity bypasses the boiler, heat pump, or space-heating water heater.

Inline Thermometer

An *inline thermometer* is a device that is used to monitor the water temperature as it circulates through the system. Two inline thermometers are installed in the heating system. One monitors the temperature of the water as it enters the supply line. The other monitors the temperature of the water as it leaves. The difference between these two measurements provides clues to the operating efficiency of the system.

Mixing Valve

A *thermostatic mixing valve* is used in a radiant heating system to recirculate a variable portion of the return water and at the same

time add a sufficient quantity of hot boiler water to maintain the required water temperature in the loops. These valves are also called *thermostatic mixing valves*, *water blending valves*, *water blenders*, *water tempering valves*, or *tempering valves*. Typical locations of mixing valves are shown in Figures 1-12, 1-13, and 1-14.

Both manual and automatic modulating mixing valves are used in hydronic heating systems. The manual mixing valve is often used to control the water temperature in a high-mass concrete slab. It is not as accurate as an automatic valve (for example, a thermostatic valve), but the high-mass concrete slab stores it and releases it slowly over a long period of time, making exact temperature control unnecessary.

The three-way and four-way thermostatic mixing valves provide automatic control of the mixed water temperatures. The valve varies the flow of hot water between its hot port and its cold port so that it can deliver through its mixed port a steady flow of water at a constant temperature.

Mixing valves are often used with high-temperature boilers designed to provide water at temperatures of more than 160°F.

Motorized Zone Valve

A *motorized zone valve* is used to control the flow of water through a single zone (see Figure 1-16). It consists of a valve body combined with an electric actuator. A radiant panel heating system will often use a number of motorized zoning valves to maintain a uniform temperature throughout the rooms and spaces in the structure. As shown in Figure 1-17, a motorized zone valve is used to control each zone. Motorized zone valves are controlled by an aquastat, individual thermostats at each loop, or a room thermostat.

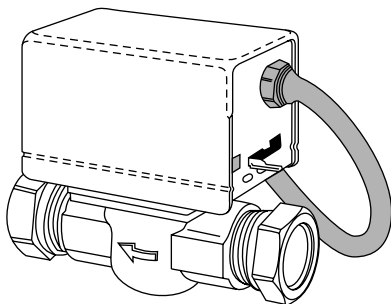

Figure 1-16 Honeywell V4043 motorized zone valve.

(Courtesy Honeywell, Inc.)

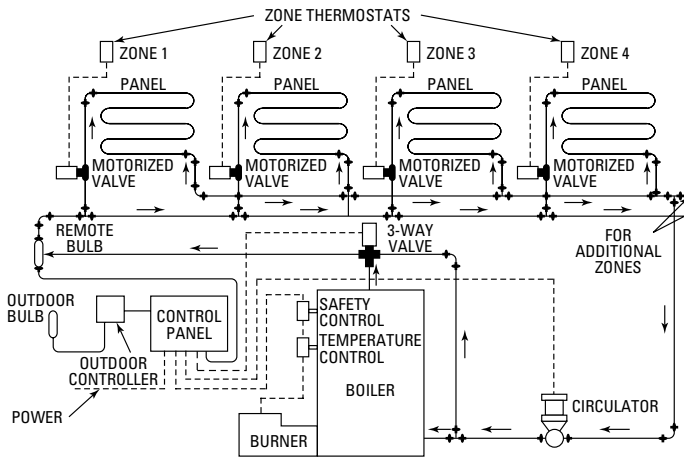

Figure 1-17 A typical control system for a multiple-zone radiant heating system. (Courtesy Honeywell Tradeline)

Note

A zone valve simplifies the piping required for a hydronic heating system because it eliminates the need for a flow check valve and relays.

Pressure-Reducing Valve

A *pressure-reducing valve* is designed to reduce the pressure of the water entering the system and to maintain the pressure at a specific minimum setting (usually about 12 lbs). A typical location of a pressure relief valve is shown in Figure 1-12.

Pressure Relief Valve

A *pressure relief valve* (also sometimes called a *safety relief valve*) is used to prevent excessive and dangerous pressure from entering the system. It is located on top of the boiler or very close to it (see Figures 1-12, 1-13, and 1-14).

Purge and Balancing Valves

Purge and balancing valves are used on either the supply or return side of the manifold in systems where multiple manifolds are served by only one circulator. Among its varied functions is (1) to allow adjustments of proper water flow for each loop; (2) to function as a shutoff valve and a drain valve for each zone or loop; (3) to control (balance) water flow through the circulation loop; and (4) to provide a means of expelling air from heating zones during initial loop fill (valve is located on the boiler return piping). If the heating system contains individual loops of unequal length, each should be equipped with a balancing valve.

Circulator

The *circulator* (circulating pump) provides the motive force to circulate the water through the radiant heating system. Sometimes a variable-speed pump is used to maintain a supply water temperature between 90°F and 150°F.

In some zoned systems, a circulator operates in conjunction with a zone thermostat instead of a zoning valve to maintain a uniform floor temperature in each room or space of the structure. The zone thermostat controls the temperature in the zone by turning the circulator on and off. The size of the circulating pump selected for a radiant panel heating system will depend on the pressure drop in the system and the rate at which water must circulate. The circulation rate of the water is determined by the heating load and the *design* temperature drop of the system and is expressed in gallons per minute (gpm). This can be calculated by using the following formula:

$$\text{gpm} \times \frac{\text{Total Heating Load}}{T \times 60 \times 8}$$

The *total heating load* is calculated for the structure and is expressed in Btu per hour. A value of 20°F is generally used for the design temperature drop (T) in most hot-water radiant panel heating systems. The other two values in the formula are the minutes per hour (60) and the weight (in pounds) of a gallon of water (8).

By way of example, the rate of water circulation for a structure with a total heating load of 30,000 Btu per hour may be calculated as follows:

$$\begin{aligned} \text{gpm} &= \frac{30,000 \text{ Btu/hr}}{20 \times 60 \times 8} \\ &= \frac{30,000}{9600} = 3.13 \end{aligned}$$

Expansion Tank

An *expansion tank* (also called a *compression tank*) is required for use in all closed hydronic radiant heating systems (see Figure 1-18). Water and other fluids expand when they are heated. The expansion tank provides space to store the increased volume to prevent stress on the system.

Air Separator

An *air separator* (also called an *air scoop* or an *air eliminator*) is a device used in a closed radiant heating system to capture and remove air trapped in the water (see Figure 1-18). Some of these devices are

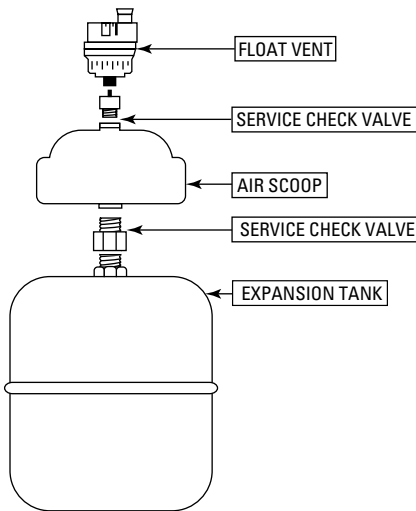

Figure I-18 Air separator and expansion tank.

equipped with tappings for the installation of an expansion tank and air vent.

Heat Exchanger

A *heat exchanger* is a device used in some radiant heating systems to separate dissimilar fluids such as water mixed with antifreeze (in snow- and ice-melting applications) and water (for radiant floor heating tubing and domestic hot water). Its function is to allow the transfer of heat between the fluids without allowing them to mix and thereby contaminate one another.

Automatic Controls

While any thermostatic method of control will function with a radiant floor heating system, the most desirable method is one based on continuously circulating hot water. The temperature of the water should be automatically adjusted to meet outdoor conditions, but the circulation itself is controlled by interior limiting thermostats instead of the simple off-on method of circulating hot water at a fixed temperature (see Figure 1-19).

Some radiant floor heating systems are designed with a thermostat for each zone (see Figure 1-17). A more common method is to group several rooms or spaces together and control them by a single thermostat. In this approach, the kitchen and dining room may be included in one thermostat-controlled loop, the bedrooms in another, the bathrooms in still another, and so on.

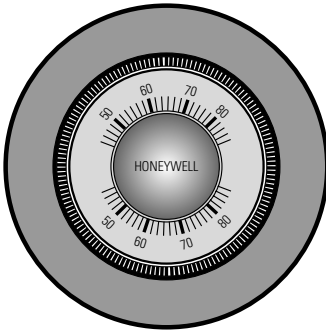

Honeywell T87F thermostat for zone control in hydronic and radiant heating systems.

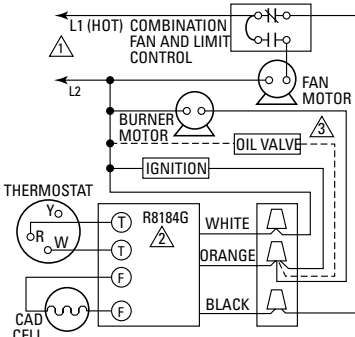
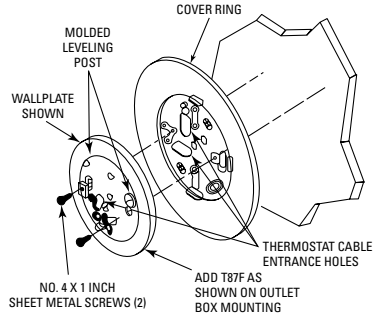

- ⚠ Power supply, provide disconnect means and overload protection as required.
- ⚠ R8184 protectorelay oil primary contains internal transformer.
- ⚠ Connect oil valve, if applicable.

T87F used for 2-wire, spst control of heating only in a typical oil system. Low voltage power for the control circuit is supplied by a transformer in the oil primary control. (Courtesy Honeywell, Inc.)

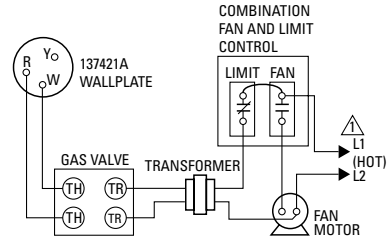

- ⚠ Power supply, provide disconnect means and overload protection as required.

T87F used for 2-wire, spst control of heating only in a typical gas system. (Courtesy Honeywell, Inc.)

Figure I-19 Examples of thermostat controls used in hydronic radiant heating systems.

Many HVAC control manufacturers are now producing control consoles such as the one shown in Figure 1-20.

Designing a Hydronic Radiant Floor Heating System

Design of a hydronic radiant floor heating system should be attempted only by those with the qualifications, training, and experience to do it right. It is *very* important that the design of a radiant panel heating system be correct at the outset. The fact that the coils or cables are permanently embedded in concrete, or located beneath

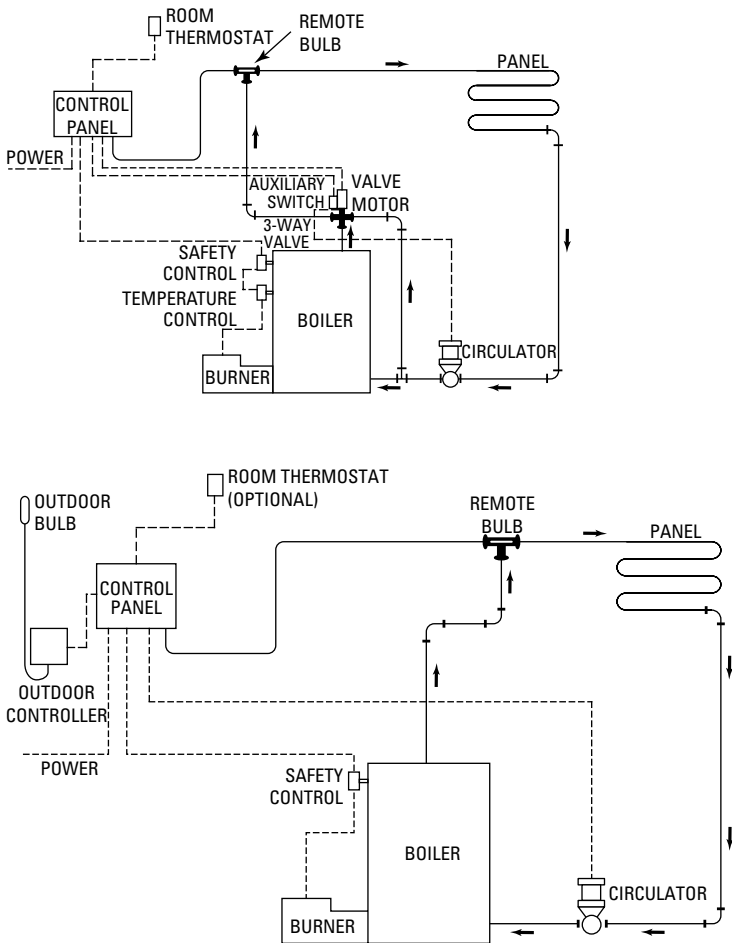
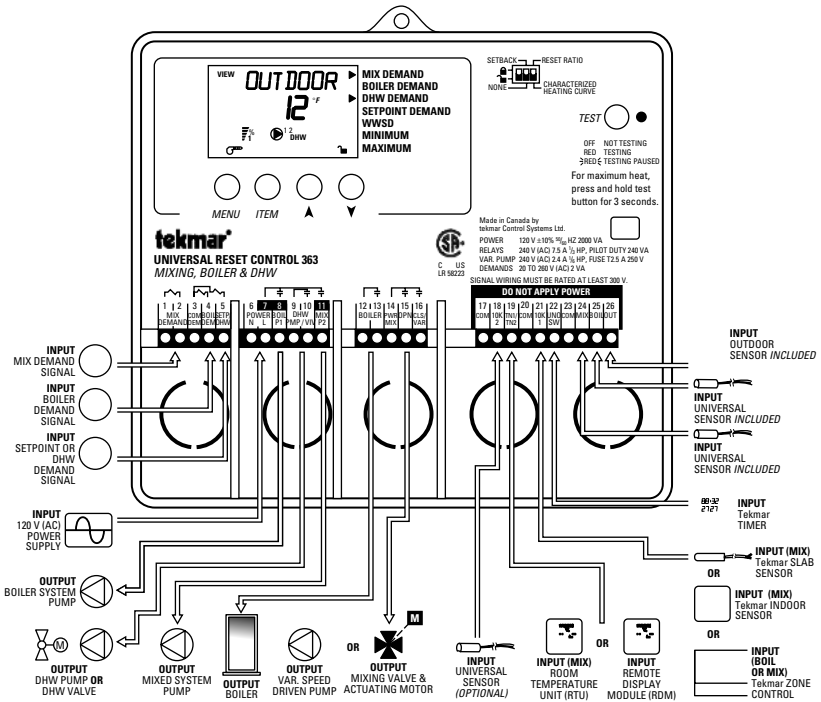

Figure I-19 (Continued)

other materials, makes corrections or adjustments very difficult and expensive.

Many manufacturers of radiant panel heating system equipment have devised simplified and dependable methods for designing this type of heating system. In most cases, the manufacturer will provide any available materials to assist in calculating the requirements of a particular radiant floor heating system. Various design manuals, manufacturer-specific installation guides, and software tools are available for use in designing and sizing radiant floor heating systems.



Tekmar Universal reset Control 363. (Courtesy Tekmar Control Systems, Inc.)

The control panel operates in conjunction with both indoor and outdoor sensors to control space and heating temperatures (multiple zones or single-zone), domestic hot water supply, slab heat, and snow-melting applications. The control panel uses an outdoor reset to adjust the boiler and mixed loop water temperatures delivered to the heating system. A variable speed driven wet-rotor circulator or a floating action driven mixing valve is used as a mixing device.

Figure I-19 (Continued)

A radiant floor heating system in which there is a constant (uninterrupted) circulation of water is the preferred design. The benefits of constant water circulation through the circuits are as follows:

- It maintains an even floor temperature.
- It prevents hot spots from forming when there is no call for heat.
- It prevents air from entering the system.
- It reduces the risk of the water freezing in systems where antifreeze cannot be used (that is, systems in which the water

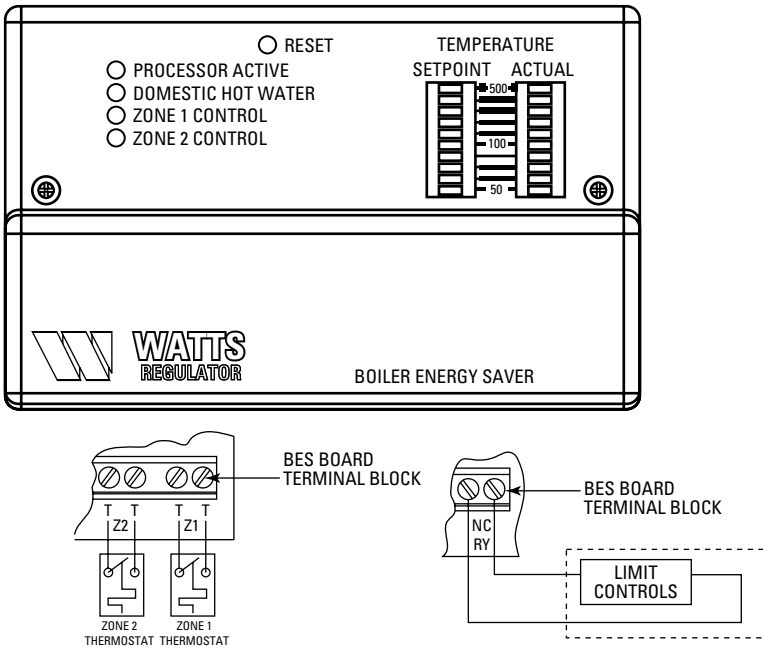

Figure I-20 Watts Boiler Energy Saver and wiring diagrams.

(Courtesy Watts Regulator Company)

heater heats both the water for space heating and the water for cooking and bathing purposes).

The flow of water in some radiant heating systems is controlled by the circulator (pump). When the room thermostat calls for heat, the pump starts and rapidly circulates heated water through the radiant panels until the heat requirement is satisfied. The pump is then shut off by the thermostat. In some systems, a flow-control valve is forced open by the flow of water through the pipes as long as the pump is running, permitting free circulation of heated water through the system. When the pump stops, the control valve closes, preventing circulation by gravity, which might cause overheating. The principal disadvantage of a system with this off-on control is that it results in temperature lag and causes the panels to intermittently heat and cool.

The continuous circulation of water through radiant heating panels is made possible by means of an outdoor-indoor control.

In this arrangement, hot water from the boiler is admitted to the system in modulated quantities when the temperature of the circulating water drops below the heat requirement of the panels. This modulated bleeding of water into the panel is accomplished through a bypass valve. When no additional heat is required, the valve is closed. When more heat is required, the valve is gradually opened by the combined action of the outdoor temperature bulb and a temperature bulb in the supply main. This system gives control by the method of varying the temperature of the water.

Air Venting Requirements

A common defect encountered in hot-water system design is improper venting. The flow of water should be automatically kept free of air binding throughout the system. Air in the pipes or pipe coils almost always results in a reduction of heat.

A practical method of venting is shown in Figure 1-21. The key to this method is the use of automatic air vents. Each air vent should be located in an area readily accessible for repair. The air trap test cock should be placed where it can be easily operated. Both the air trap and the air trap test cock must be located where they are not subject to freeze-up, as both are noncirculating except during venting operation (automatic or manual).

Sizing Calculations

The successful operation of any hot-water heating system requires the incorporation of design provisions that ensure an even and balanced flow of water through the pipes or coils of the installation.

The procedure for designing a hydronic radiant floor heating system may be outlined as follows:

1. Determine the total rate of heat loss per room in the structure.
2. Determine the available area for panels (loops) in each room.
3. Determine the output required by each panel to replace the heat loss.
4. Determine the required surface temperature for each panel.
5. Determine the required heat input to the panel (should equal heat output).
6. Determine the most efficient and economical means of supplying heat to the panel.
7. Install adequate insulation on the reverse side and edges of the panel to prevent undesirable heat loss.
8. Install the panels opposite room areas where the greater heat loss occurs.

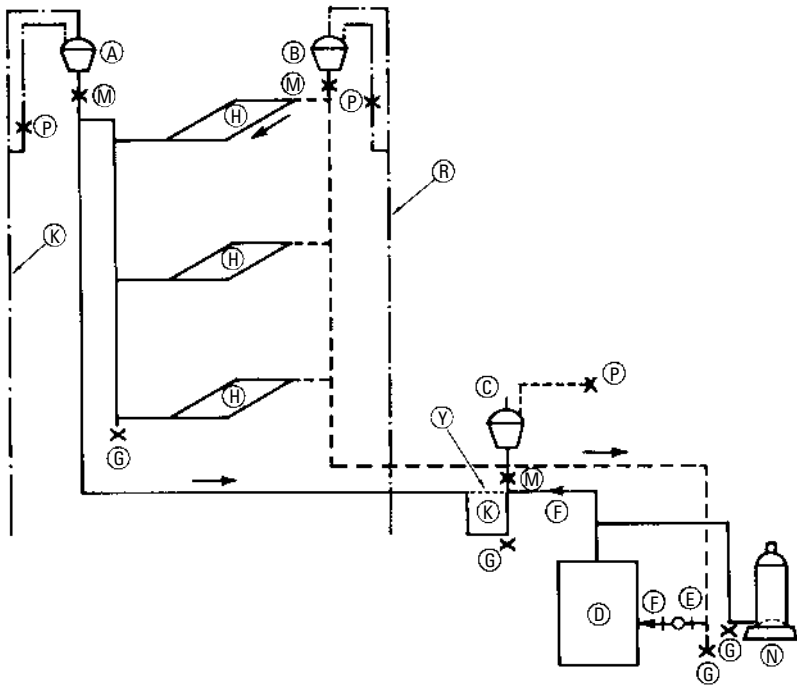

Symbols: → Indicates downward grade of tubing. (A) automatic air trap at top of main flow riser; (B) automatic air trap at top of main return riser; (C) automatic air trap at top of special loop (K) required by possible obstruction and when small size vent by-pass is also not permissible at (Y); (D) heater; (E) pump; (F) check valve; (G) drain valve; (H) heating panel coil; (K) loop in main flow (See (C)); (M) trap shut-off valve (for repair); (N) expansion tank; (P) manual test cock (air trap); (R) open and automatic vent tube (½ in. copper).

Note—By reversing direction of grade at (H) air trap (B) can be eliminated. Same riser vent layout should be used for up-feed systems. Test cocks (P) should be located accessible for occasional use. Open ends of vent tubes (R) (normally dry) can discharge visibly into nearest drain or sink.

Figure I-21 An automatic vent radiant heating system.

Note

Always keep floor temperatures at or slightly below recommended high limits.

Radiant Floor Construction Details

Radiant floor construction can be divided into two broad categories based on the installation method used: (1) wet installation and (2) dry installation. The *wet installation method* involves completely embedding the tubing in a concrete slab or covering it with a thin layer of concrete (commonly a gypsum-based lightweight pour).

The *dry installation method* is so-called because the tubing is installed without embedding it in concrete.

The examples of radiant floor construction described in this section represent the most commonly used forms. They are offered here only as examples, not as planning guides for contractors. The actual construction plans will depend on the design of the hydronic radiant floor heating system, the impact of local building codes and regulations, and other variables.

Slab-on-grade construction

In slab-on-grade construction, the tubing is attached to a wire mesh or special holding fixtures to keep it in place until the concrete is poured around it. The tubing loops are embedded in the middle of the concrete slab and are located approximately 2 inches below the slab surface (see Figure 1-22). A brief summary of the steps involved in slab-on-grade construction is as follows:

1. Compact the soil base to prevent uneven settling of the slab.
2. Cover the compacted soil with a lapped 6-mil vapor barrier.
3. Cover the vapor barrier with 2-inch-thick extruded polystyrene insulation.
4. Install rigid polystyrene insulation vertically on the inside surface of the exterior foundation walls to prevent edgewise (horizontal) heat loss.
5. Lay concrete reinforcing mesh over the insulation.
6. Position the tubing on top of the reinforcement mesh according to the tubing layout plan.
7. Tie the tubing to the reinforcement mesh with tie straps or wire.
8. Cover the tubing with a minimum of 9 inches of concrete.

Thin-Slab Construction

In this type of wet installation, a layer of lightweight concrete or lightweight gypsum is poured over the tubing to form a thin slab (see Figure 1-23). Thin-slab construction is used over a wood subfloor supported by wood framing.

A summary of the steps involved in forming a thin-slab floor system using poured concrete to form the slab may be outlined as follows:

1. Apply a lapped 6-mil polyethylene vapor barrier to the wood subfloor.
2. Position the tubing on the subfloor according to the tubing layout plan.

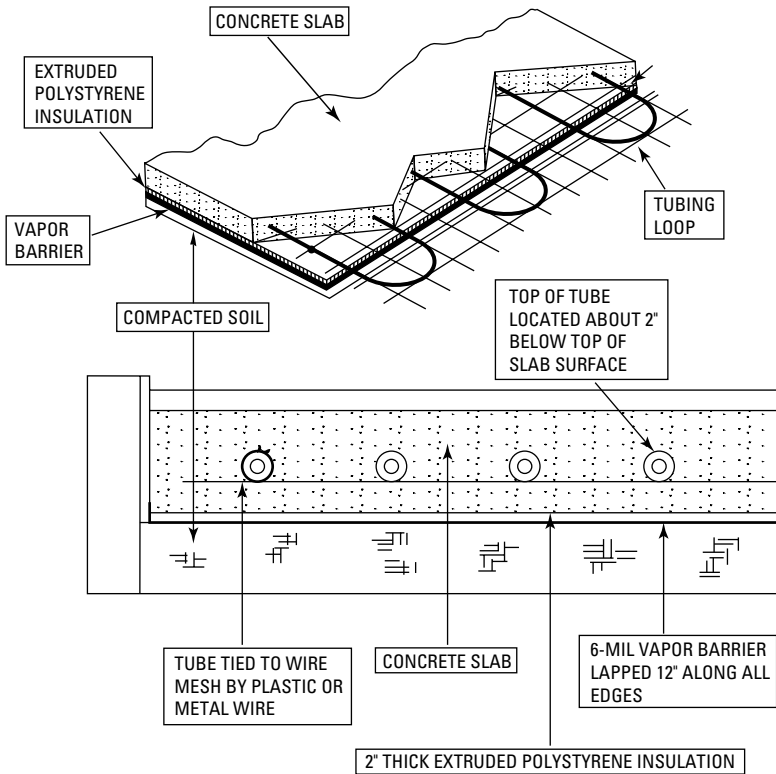

Figure 1-22 Slab-on-grade construction.

3. Fasten the tubing to the wood subfloor with plastic clips or metal staples.
4. Pour concrete over the tubing and subfloor.
5. Install batt insulation in the joist cavities beneath the subfloor. If lightweight gypsum cement instead of concrete is used to form the slab, pour the gypsum in two stages. The first pour should be no higher than the tops of the tubes. When this first layer dries, it will shrink slightly and pull back from the tubing. Apply a second layer of gypsum to completely cover the first layer and the tops of the tubing.

Sandwich Floor Construction

Sandwich floor construction is available in a number of different configurations (see Figure 1-24). This construction method involves

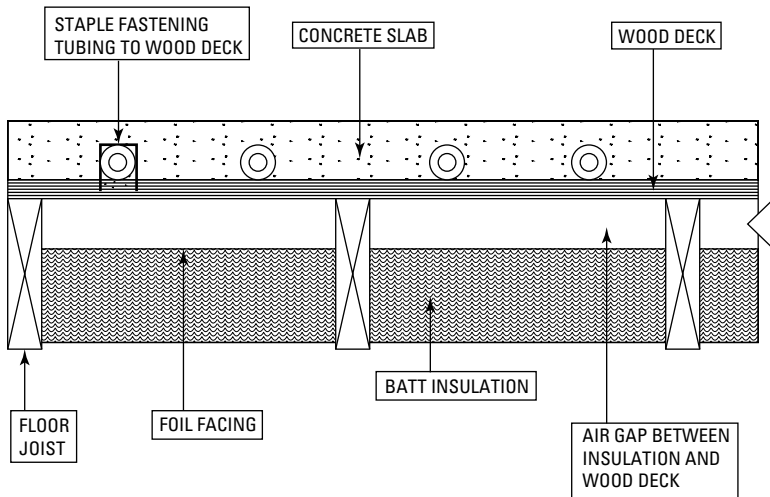

Figure 1-23 Thin-slab construction details.

locating the tubing between the subfloor and additional flooring layers. In some cases, aluminum plates are added for heat dispersion. The two layers of a sandwich floor have wood sleepers installed between them for adding the tubing and subsequent flooring layers. These systems all contain less thermal mass than slab systems, and some allow for more rapid temperature responsiveness.

Staple-Up Method

In the staple-up method, the tubing is located below the subfloor. This method of installing tubing is very common in both new construction and remodeling work. Its use is recommended when retrofitting because it avoids the problem and expense of having to remove the existing floor covering.

Note

The staple-up construction method will require drilling holes for the tubing in some of the supporting joists.

The staple-up construction method illustrated in Figure 1-25 is used without heat transfer plates. The tubing is fastened to the bottom of the subfloor in the joist cavities. Install either 3½-inch batts or 2-inch polystyrene rigid insulation in the joist cavities below the tubing with a 1½- to 4-inch air gap between the subfloor and the insulation.

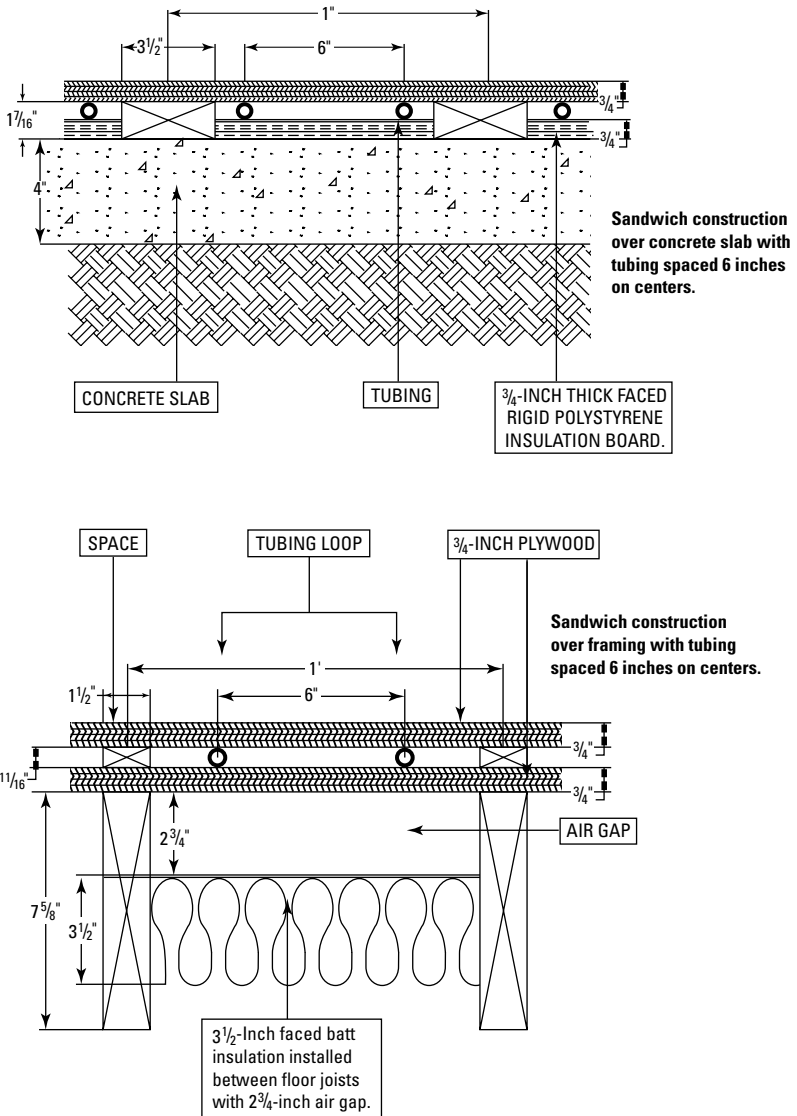

Figure I-24 Examples of sandwich floor construction.

(Courtesy Watts Radiant, Inc.)

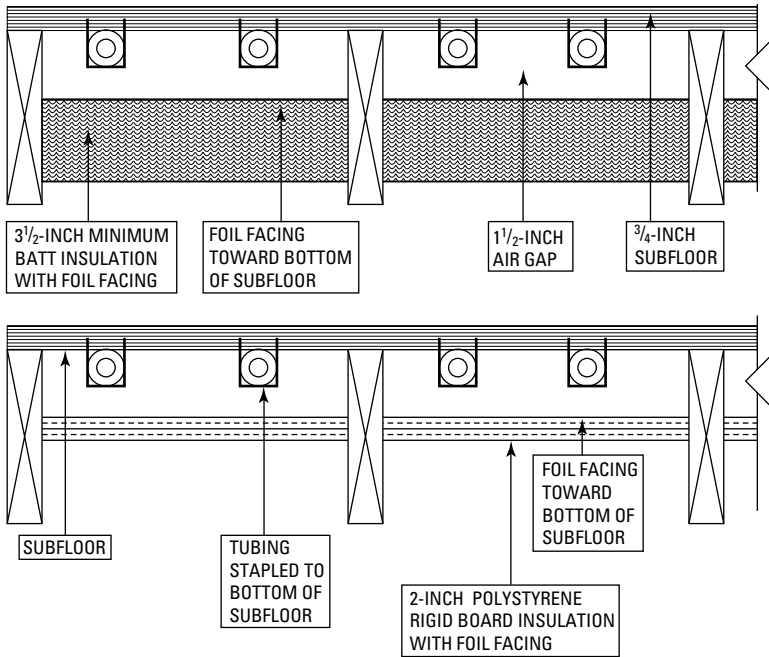

Figure I-25 Staple-up method.

The heating efficiency of the staple-up construction method can be greatly improved by adding preformed, grooved aluminum heat transfer plates beneath the subfloor (see Figure 1-26). The plates are stapled to the bottom of the subfloor in the joist cavities, and the tubing is inserted in the preformed plate grooves. Insulation is installed beneath the tubing with a 2- to 4-inch air space between the top of the insulation and the bottom of the subfloor. The heat from the tubing spreads horizontally across the plate surface and then flows upward into the room or space above the floor. Without these plates, a percentage of the heat from the tubing is lost because it flows down into the spaces below the room being heated. To compensate for the heat loss, the heating system must operate at higher temperatures. This results in higher heating costs.

A variation of the staple-up construction method is to hang the tubing several inches below the subfloor in the joist cavities. Aluminum heat-transfer plates are fastened to the bottoms of the floor joists leaving an air gap between the plates and the bottom of the subfloor.

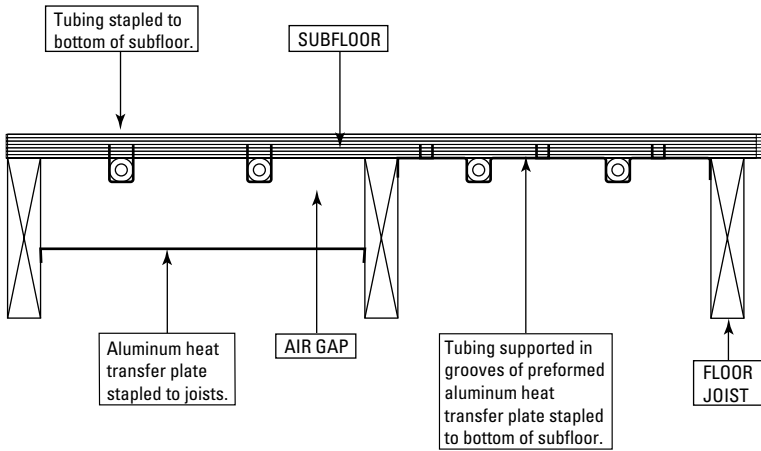

Figure I-26 Staple-up method with heat transfer plates.

Tubing Installed Above the Subfloor

Figure 1-27 illustrates a common dry installation method of installing the tubing above the subfloor. It consists of wood sleepers nailed to the top surface of the wood subfloor with the tubing located in the spaces between the sleepers. Plywood is nailed to the tops of the sleepers to support the floor covering material.

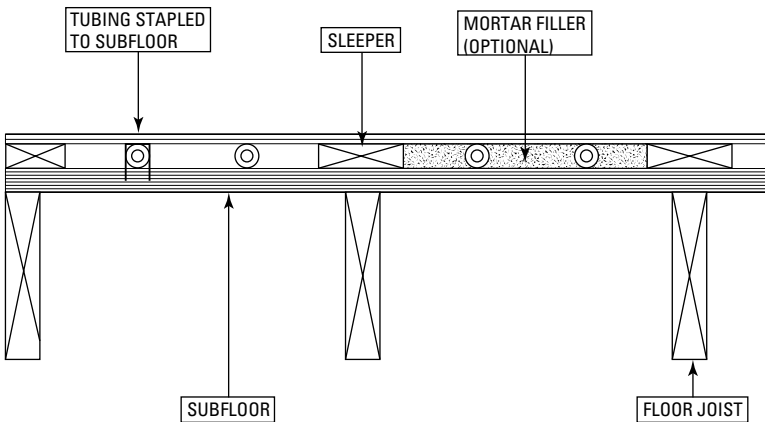

Figure I-27 Tubing installed above the subfloor between sleepers.

Note

A loose, noninsulating masonry filler poured around the tubing will increase the thermal mass of the floor. Do not use loose fill insulation, such as perlite or vermiculite. These are insulating materials that will interfere with the heat radiation from the tubing. Masonry filler is not an insulating material.

An alternative method is to install heat-transfer plates between the sleepers and use the plates to support (cradle) the tubing. In both cases, a suitable insulation must be installed between the floor joists (see Figure 1-28).

Still another method is to install factory-made, grooved wood panels beneath the finished floor. The dimensions of the panels may vary, depending on the manufacturer. The tubing is inserted in the panel grooves and set flush with the panel surface.

Floor Coverings

Floor covering materials reduce the amount of heat radiation rising into the room or space above the floor. The insulating properties of floor coverings must be considered when designing a hydronic or electric radiant floor heating system. Plush carpets and polyurethane carpet pads should not be installed over a radiant floor heating system. The same holds true for thick wood floors or multiple layers of plywood subfloors. Both have a high thermal resistance.

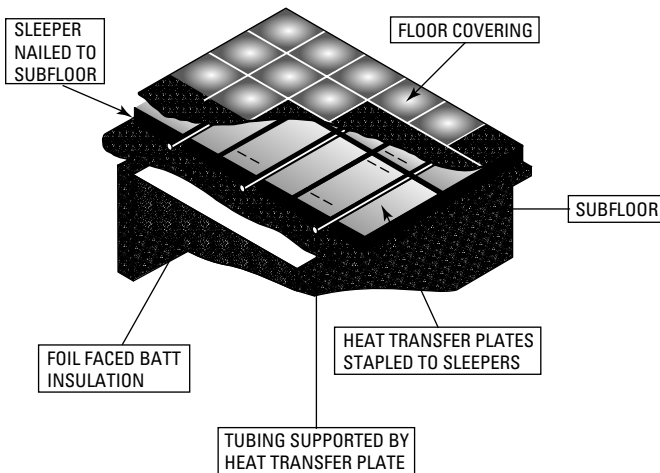

Figure 1-28 Tubing installed above the subfloor between sleepers with heat-transfer plates. (Courtesy Weil-McLain)

Carpets are commonly installed over a carpet pad. The combined carpet and cushion R-value (that is, its insulating value) should not exceed a maximum of R-4.0. Use either a foam rubber or waffle rubber pad. To reduce the resistance even further, consider eliminating the carpet pad.

Sheet final and tile floor coverings radiate the heat much faster than carpet, thereby reducing the lag time between when the hot water flows through the circuit and the heat is actually delivered to the room or space above.

Coils and Coil Patterns

Hydronic radiant floor heating panels are available as prefabricated units, or they can be constructed at the site. The principal coil patterns used in radiant floor heating systems are the following:

1. Coil pattern for uniform heat distribution.
2. Coil pattern for perimeter heat distribution along two walls.
3. Coil pattern for perimeter heat distribution along one wall.

Counterflow Spiral Tube Layout Pattern

The tube layout illustrated in Figure 1-29 provides the most even and uniform heat distribution for a room in a radiant floor heating system. It accomplishes this by running the supply and return lines parallel to one another. As a result, an average temperature is created between the tubes.

Double Serpentine Layout Pattern

In some rooms, there will be a significant amount of heat loss through two adjacent exterior walls. As shown in Figure 1-30, the supply tubing runs along the perimeter of the walls where the hot water can provide maximum heat transfer. It then turns inward in a series of serpentine-like loops to the center of the room (the area of lowest heat loss) before returning to the manifold.

Single Serpentine Layout Pattern

If a major heat loss occurs along a single exterior wall, the supply tubing runs along the perimeter of that wall before returning in a series of serpentine loops to the return manifold (see Figure 1-31).

In a well-designed hydronic radiant floor heating system, the linear travel from the heating unit and pump should be the same for each of the panels (see Figure 1-32). This will result in the flow through each panel being in natural balance.

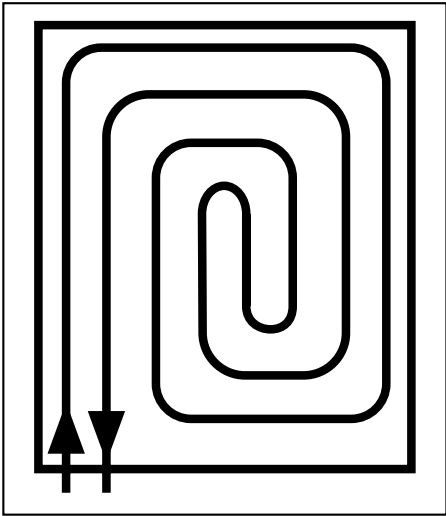

Figure I-29 Counterflow spiral tube layout pattern.

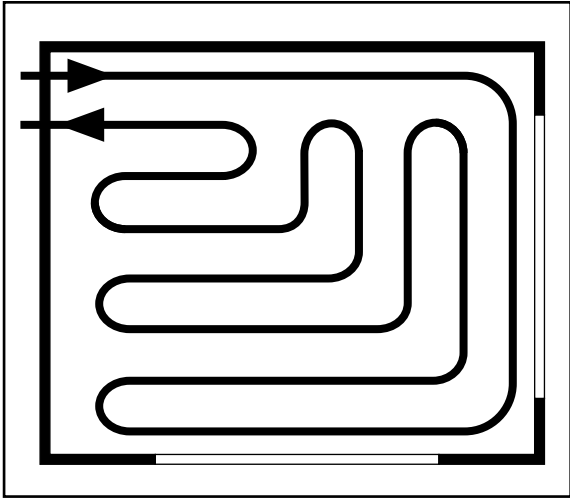

Figure I-30 Double serpentine layout pattern.

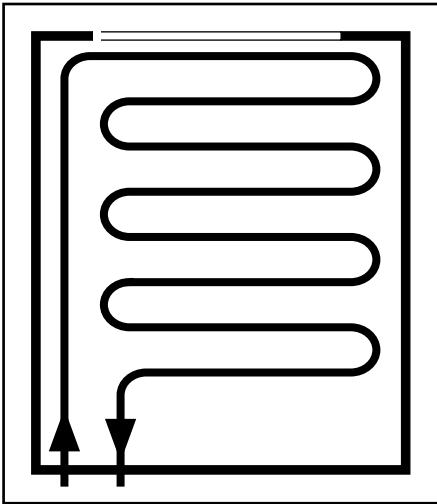

Figure 1-31 Single serpentine layout pattern.

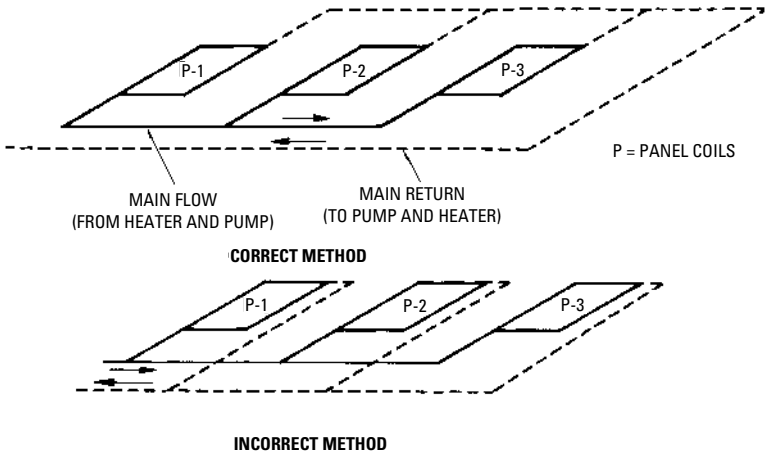

Figure 1-32 Correct and incorrect method of laying out a forced hot-water distribution system. The travel from pump and heater should be the same through P₁, P₂, and P₃ as shown in the correct method.

Installing a Hydronic Radiant Floor Heating System (PEX Tubing)

These installation recommendations are provided for general information only. The architect or HVAC contractor is responsible for all design details and installation procedures for the specific radiant floor heating system. The architect or contractor is also responsible for maintaining the work in compliance with all applicable building codes, local and national.

Note

Install all the components of a hydronic radiant floor heating system in accordance with the equipment manufacturer's instructions and all applicable codes. Failure to do so could result in severe personal injury, death, or substantial property damage.

Installation Recommendations

The following installation recommendations are provided as a general reference. Each manufacturer will provide instructions specific to its product.

System Inspection

After the PEX tubing has been embedded or concealed, it becomes a relatively permanent part of the structure. Because of the difficulty of servicing embedded or concealed loops, it is essential that a final inspection be performed to make sure the tubing or piping has not been damaged during construction and that all tubing or piping loops have been installed in compliance with local codes and ordinances. Check the following:

- Check to make sure the tubing or piping loops have been installed according to the layout (coil patterns) in the building plan.
- Inspect the tubing or piping for kinks, scrapes, slits, or crush damage.
- Inspect the tubing or piping for correct spacing.
- Make sure all manifolds are correctly located and provide easy access.
- Check to make sure the tubing or piping connections to the manifold are tight.
- Make sure the tubing or piping is properly fastened and there is a correct spacing maintained between the fasteners.

Tubing Length and Diameter

It is important to know the length and inside diameter (ID) of the tubing when creating a circuit (loop). Excessive circuit lengths will result in a significant temperature drop in the circuit. The temperature drop

is the difference between the supply (hotter) water entering the circuit and the return (cooler) water leaving the circuit. In residential heating systems, the temperature drop is normally 15–20°F. If the temperature drop is greater than 15–20°F, it will result in insufficient heat and/or uneven heat being delivered to the room or space.

Long loops also result in increased friction in the tubing, which slows the flow rate of the water. This pressure drop must be overcome by the circulator (pump) in order to maintain a uniform flow rate for the water in the tubing.

A typical residential hydronic radiant heating system uses 1/2-inch-ID tubing. The maximum recommended length for this diameter is 300 feet. Most circuits (loops) in residential heating systems are shorter (about 100 to 250 feet long). Tubing with an ID of 5/8-inch or 3/4-inch, on the other hand, can be used in circuits up to a maximum of 450 feet in length.

In addition to the tubing ID, the length of the tubing required per square foot of floor will also be affected by such variables as the type of slab used, the heat load for the structure, the type of appliance (boiler, water heater, or heat pump), the type of controls used, and even the climate.

Tubing Spacing

Another important factor to consider when designing and installing a hydronic radiant floor heating system is the spacing of the tubing in the loops. Most residential heating systems are based on the use of 1 to 1½ linear feet of 1/2-inch-ID tubing per square foot of floor area with the tubing spaced 9 to 12 inches apart. That is only a general rule, however, because there are situations where the tubing must be spaced closer to increase the heat output (for example, under windows, along cold exterior walls, and so on). A 3-inch to 6-inch spacing of the tubing will require 2 to 4 linear feet of tubing per square foot of heated floor area.

Loop Continuity

The tubing loop extending from the manifold supply port to the manifold return port must be one continuous length. Never splice together two lengths of tubing to form a loop. Doing so will weaken the loop.

Insulation

Install insulation beneath the tubing to prevent the downward loss of a portion of the heat. In uninsulated slab-on-grade construction, for example, a portion of the heat will be lost to the ground. The ground becomes a heat sink if there is no insulation installed. Use 1- to 2-inch-thick rigid polystyrene to insulate a slab-on-grade radiant heating system. Batt and blanket insulation are also in other types of radiant

heating systems. See “Radiant System Construction Details” for examples of the use of the different types of insulation.

Vapor Barrier

A vapor barrier of 6-mil polyethylene sheeting should be installed between a thin slab and the wood sheathing to limit the transfer of moisture from the slab to the wood. Check the local building code for the use of a vapor barrier. Not all codes require it.

Panel Testing Procedures

Radiant heating coils should be tested for leaks after they have been secured in position but before they are covered with concrete or some other covering material. Both a compressed-air test and a hydraulic pressure test are used for this purpose.

The compressed-air test requires a compressor, a pressure gauge, and a shutoff valve. The idea is to inject air under pressure into the radiant heating system and watch for a pressure drop on the gauge. A continually dropping pressure is an indication of a leak somewhere in the system.

The pressure gauge is attached to one of the radiant heating coils, and the shutoff valve is placed on the *inlet* side of the gauge in a valve-open position. The air compressor is then connected, and compressed air is introduced into the system under approximately 100 psi. After the introduction of the air, the shutoff valve is closed and the compressor is disconnected. The system is now a closed one. If there are no leaks, the air pressure reading on the gauge will remain at approximately 100 psi. A steady drop in the air pressure reading means a leak exists somewhere in the system. A leak can be located by listening for the sound of escaping air. Another method is to use a solution of soap and water and watch for air bubbles.

The hydraulic pressure test requires that the coils be filled with water and the pressure in the coils be increased to approximately 275 to 300 psi. Care must be taken that *all* air is removed from the coils before the system is closed. The system is then closed, and the gauge is watched for any change in pressure. A leak in the system will be indicated by a steady drop in pressure on the gauge. The source of the leak can be located by watching for the escaping water. If a leak is discovered, the coil should be repaired or replaced and a new test run on the system.

Installation Guidelines

Guidelines

- Run the tubing parallel to the wall or walls with the greatest heat loss. (continues)

Guidelines *(continued)*

- Maintain a 12-inch gap between the outermost tubing and an exterior wall.
- Space tubing 6 inches o.c. between the first two loops along the wall or walls with the greatest heat loss.
- Tie tubing every 3 feet or less with plastic tie wraps. Note: Never tie tubing anywhere within the end of a loop.
- Always use a vapor barrier under the slab. Note: Place the vapor barrier between the ground and insulation, if the latter is used under the slab.
- Place a vapor barrier between the soil and any insulation installed under the slab.
- Insulate under the slab if groundwater comes within 3 feet.
- Always install edge insulation along the foundation walls to prevent edgewise (horizontal) heat loss.

Whenever possible, follow the radiant heating system manufacturer's installation guidelines. The procedure described here for installing a hydronic radiant floor heating system (using PEX tubing) is offered as a general guideline. It may be outlined as follows:

1. Attach the manifold wall brackets to the wall.
2. Assemble the manifold (if it is not a factory-assembled unit) and clamp it into position on the wall brackets.
3. Mount a pipe bend support directly below the manifold to hold the supply pipe.
4. Connect the supply pipe to the manifold and lay out the pipe loop by following the layout plan.
5. Mount a pipe bend support below the manifold to hold the return pipe.
6. Create coil pattern.
7. Cut the return pipe and connect it to the manifold.
8. Mark or number the first loop for identification.
9. Check the length of the first loop against the layout plan by using the length markings on the outside of the pipe. A significant deviation in overall length between the layout plan and the installed pipe loop will require an adjustment of the loop balance settings.
10. Repeat steps 1 through 8 for the remaining loops in the system.

11. Close the supply, return, and shutoff valves on the first manifold.
12. Connect hoses to the end caps on the manifold.
13. Connect the end of one of the hoses to the main and the end of the other hose to a drain.
14. Open the end cap valves for filling and draining the system.
15. Open the supply and return valves on the manifold for the first loop.
16. Turn on the water and allow it to flow through the loop until all the air has been expelled. Purging the air from the system is a very important step. Air trapped in the loops will cause the system to operate inefficiently.

Note

If the water will not flow through the loop, the pipe may be buckled or crimped or there may be a blockage at the manifold connection. Check and repair before proceeding to the next step.

17. Repeat steps 10 through 15 until each loop in the heating system has been filled with water and any air trapped in the piping has been removed.
18. Open all the system valves and perform a pressure test (at 3 to 4 bar pressure). The pressure will drop during the first few hours and then remain stable if there are no leaks and the ambient temperature remains constant.
19. Install the floor covering (cement, carpet, tiles, and so on).
20. Close all the loop valves and open the shutoff valves.
21. Fill the boiler and the supply pipes with water, and purge the air. Open every valve and fixture (faucets and so on) in the system and continue purging until all the air trapped in the pipes has been pushed out of the lines and the water flows freely from the fixtures. Purge the air from the end caps at each end of the manifolds. In a structure with several floors, purge the air from the manifold located at the lowest level first.

Note

There must be shutoff valves on the manifolds to properly purge air from the loops.

22. Open all the loops in the heating system and check to make sure the air has been removed. If there is still air in the tubing, repeat steps 20 and 21 until all air has been removed.
23. Place the system under pressure by starting the boiler and circulator.

Servicing and Maintaining Hydronic Radiant Floor Heating Systems

Hydronic radiant floor heating systems require very little service and maintenance, but this does not mean they should be ignored. The following recommendations apply to all floor heating systems:

- Check the system pressure on a regular basis. An incorrect pressure reading may indicate air trapped in the system. An air pocket or bubble will block the flow of water and cause pressure readings outside the norm.
- Check the system for leakage. If the tubing is attached under the floor to the stud bottoms, access to the tubing or tubing connections to make repairs is relatively easy. If the tubing is embedded in cement above the subfloor, however, locating a leak is more difficult and expensive.
- Check to make sure there is enough water in the system. If not, it may need refilling.

If purging air, repairing leaks, and/or refilling the system with water does not result in maintaining the required pressure in the system, ask for a service call from a certified HVAC technician with experience in hydronic floor radiant heating systems.

Troubleshooting Hydronic Floor Radiant Heating Systems

Problems with hydronic floor radiant heating systems (see Table 1-1) will occur in the following areas:

1. Heating appliance (boiler, heat pump, or water heater)
2. Circulator (circulating pump)
3. Automatic controls
4. Tubing

Most of the troubleshooting and repair procedures for the various components of a hydronic floor radiant heating system have been described in considerable detail in other chapters. Use the volume index to locate those sources of information.

The first step when troubleshooting a radiant floor system is to check the controls. Turn the room thermostat on or off and wait for a few minutes for the system to respond. If the system responds by turning on or off within 2 or 3 minutes, the controls are not the problem.

Table 1-1 Troubleshooting Hydronic Floor Radiant Heating Systems

Symptom and Possible Cause	Suggested Remedy
Insufficient heat.	
(a) Slow initial response time.	(a) Normal for hydronic floor heating system.
(b) Insufficient heat generally occurring on design temperature day.	(b) Improper system design; add auxiliary heat.
(c) Boiler or other heat source problem.	(c) Check heat source for problem and correct.
(d) Defective floor sensor.	(d) Replace.
No heat.	
(a) Defective room thermostat and/or floor sensor.	(a) Replace thermostat and/or floor sensor.
(b) Boiler or other heat source problem.	(b) Check heat source for problem and correct.
(c) Defective circulator.	(c) Test; repair or replace.
Floor temperature too hot or too cold.	
(a) Defective mixing valve.	(a) Replace defective valve.
(b) Incorrect mixing valve setting.	(b) Adjust valve setting; change valve setting number according to specifications in manufacturer's installation manual.
(c) Defective outdoor air sensor.	(c) Test and replace.
Floor temperature too cold.	
(a) Boiler or other heat source problem.	(a) Check heat source for problem and correct.
(b) Circulator working against large system temperature drop; not moving enough water.	(b) Check temperature drop when system is warm; circulator is undersized if drop is found to be too large; correct as necessary.

Table I-1 (continued)

Symptom and Possible Cause	Suggested Remedy
(c) Circulator working against small system temperature drop; water and floor temperatures almost equal, resulting in little heat transfer.	(c) Check temperature drop when system is warm; circulator is oversized if temperatures almost equal; increase floor temperature if less than 85°F to be too large.
Hot spot in floor.	
(a) Excessive high and concentrated temperatures in floor caused by tubing or tubing connection break.	(a) Locate break and repair.

Check the boiler, heat pump, or water heater for a problem. These appliances and their troubleshooting methods are described in Chapter 15 (“Steam and Hydronic Boilers”) in Volume 1, Chapter 10 (“Heat Pumps”) in Volume 2, and Chapter 4 (“Water Heaters”) in Volume 2, respectively.

Note

Some heating systems have a thermometer installed in the circulation loop. The thermometer displays the temperature of the circulating water. A low fluid temperature displayed *while the circulator is operating* will indicate a problem with the boiler, heat pump, or water pump.

The troubleshooting and repair of circulators (water-circulating pumps) is covered in Chapter 10 (“Steam and Hydronic Line Controls”) in Volume 2.

Problems requiring repairs or replacements of the manifolds or loops, especially embedded loops in wet installations, require the expertise of HVAC technicians experienced in the installation and maintenance of floor radiant heating systems.

Hydronic Radiant Heating Snow- and Ice-Melting Systems

Radiant systems used to melt snow and ice on driveways, sidewalks, and other outdoor surfaces are inexpensive to operate because they are used only when required. They begin to operate at a reduced output mode when the outdoor temperatures drop below a certain preset point and then switch to full operation when rain or snow reaches the surface.

The simplest form of control for snow-melting and ice-melting installations is a remote, manually operated on-off switch. The switch is commonly located inside the garage and operated only when required. Some snow- and ice-melting installations are operated by an automatic control system connected to a thermostat and a heating boiler, heat pump, or water heater.

Because the tubes carrying the heated water are located outdoors beneath the driveway surface, an antifreeze solution such as propylene glycol should be added to protect the system from freezing.

Electric Radiant Floor Heating

A number of manufacturers produce electric radiant floor heating systems for use in residential and light commercial construction. They are safe, relatively easy to install, and extremely energy efficient.

Note

Electric radiant heating produces electromagnetic fields, and these EMFs may cause health problems. The potential health risk from EMFs can be minimized or even eliminated by (1) following the wiring and grounding methods recommended by the *National Electrical Code*; (2) purchasing and installing a radiant heating system that produces very low EMFs (some manufacturers claim zero EMFs for their systems); and (3) avoiding systems that produce EMFs higher than 2 mG at 2 feet.

Most of these electric radiant floor heating systems consist of a thin electric mat or roll applied to the subfloor where it is embedded in a thinset or self-leveling cement. Watts Radiant manufactures heating mats (HeatWeave UnderFloor mats) for installation between the floor joists under the subfloor.

System Components

An electric floor heating system in which electric heating mats or rolls are used will include some or all of the following components, depending on the system design:

1. Heating mats or rolls
2. Thermostat
3. Floor sensor
4. Ground fault circuit interrupter
5. Relay contactor
6. Timer
7. Dimmer switch

Heating Mats or Rolls

The electric mats or rolls used in electric floor radiant heating systems are made of coils of heat resistance wire joined to a supporting material. They are only $\frac{1}{8}$ inch thick, which means they can be installed over the subfloor and under the floor covering without significantly raising the floor level (see Figure 1-33). The heating element of a constant-wattage electric heating cable or wire operates on 120 volts or 240 volts.

Electric heating mats or rolls are produced in a wide variety of sizes to fit different floor dimensions. Custom sizes can also be ordered from manufacturers to fit areas with curves, angles, and other nonstandard shapes.

An entire electric radiant floor heating system can be ordered from any one of the manufacturers listed in the sidebar. When ordering the materials for one of these heating systems, send them an installation layout plan listing the exact dimensions of the rooms or spaces to be heated. The plan may be for an entire house, an addition to a house, or a single room or space.

Note

The manufacturer will cut the mats or rolls to the sizes listed in the installation plan. Once the mats or rolls are cut, they cannot be returned if a mistake is discovered unless it can be shown that the manufacturer was at fault.

The recommended heating capacity for electric resistance heating is specified by the building codes on a watt-per-square-foot-of-living-area basis. The electric heating mats or rolls are designed to draw 8 to 15 watts per square foot. Their operation is very similar to that of an electric blanket.

Manufacturers of Electric Radiant Heating Mats or Rolls

Flextherm, Inc.
2400, de la Province Street
Longueuil, Quebec J4G 1G1
Canada
450-442-9990
800-353-9843
www.flextherm.com

Heatway, Inc. (Watts Heatway, Inc.)
3131 W. Chestnut Express Way
Springfield, MO 65802
800-255-1996
www.heatway.com

(continues)

Manufacturers of Electric Radiant Heating Mats or Rolls *(continued)*

NuHeat Industries Ltd.
1689 Cliveden Ave.
Delta, BC V3M 6V5
Canada
800-778-9276
604-529-4400
www.nuheat.com

SunTouch Electric Floor Warming
A Division of Watts Radiant, Inc.
3131 W. Chestnut Expressway
Springfield, MO 65802
417-522-6128
www.suntouch.net

WarmlyYours, Inc.
1400 E. Lake Cook Road, Suite 140
Buffalo Grove, Illinois 60089
800-875-5285
www.WarmlyYours.com

Warmzone, Inc.
Salt Lake City, Utah
888-488-9276
801-994-8450
www.warmzone.com

Watts Radiant, Inc.
A Division of Watts Water Technologies, Inc.
31341 West Chestnut Expressway
Springfield, Missouri 65802
800-276-2419
978-688-1811
www.wattsradiant.com

Automatic Controls

The automatic controls of a typical electric radiant floor heating system consist of a thermostat, a GFCI safety breaker, and an optional timer. If a floor-heating thermostat is used instead of a room thermostat, the former is wired to a floor sensor that detects the actual floor temperature. A GFCI and a timer are integral components of a floor-warming thermostat.

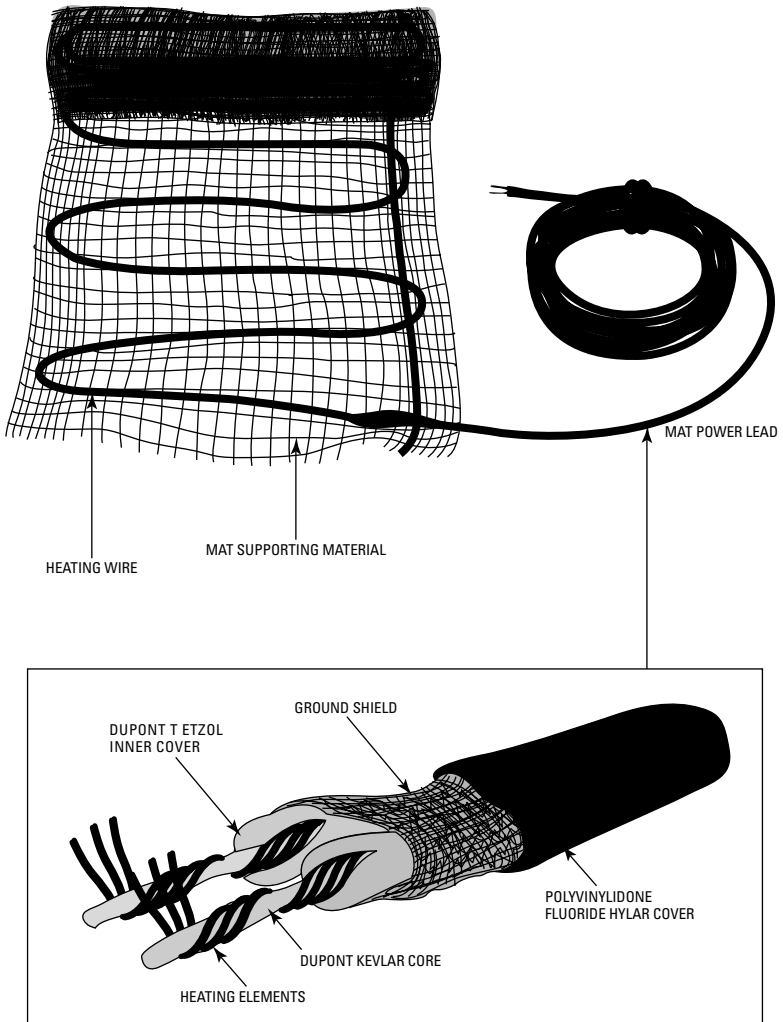

Figure I-33 Construction details of a typical electric heating mat or roll. (Courtesy Watts Radiant, Inc.)

Thermostat

The *thermostat* is the controlling device for an electric radiant floor heating system. Most modern systems use a *programmable thermostat*, which contains an integral ground fault circuit interrupter (GFCI) and a manual high-low temperature setback switch

(see Figure 1-34). A programmable thermostat is connected to an embedded floor sensor that monitors the floor temperature and transmits it to a digital display on the thermostat. A programmable thermostat can be programmed for four setting changes each day of the week.

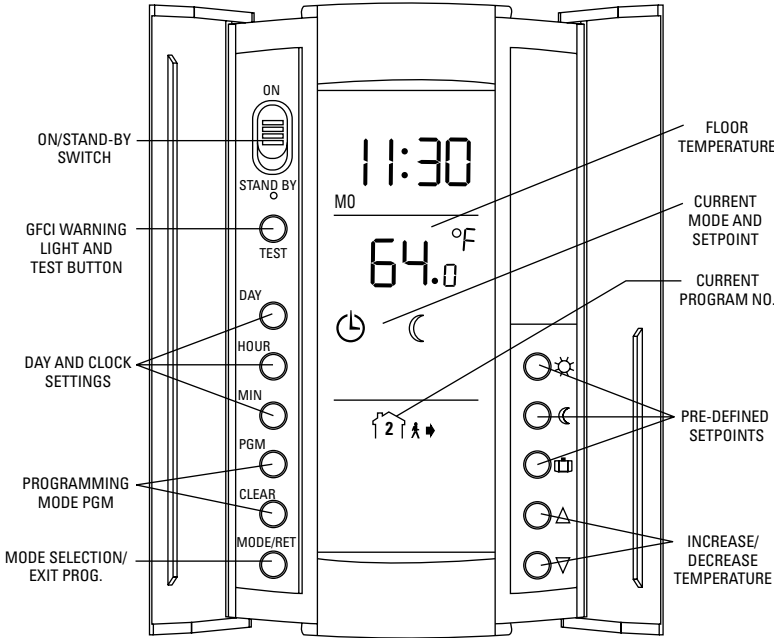

Figure 1-34 Programmable thermostat with digital display for an electric radiant floor heating system. (Courtesy Watts Radiant, Inc.)

Nonprogrammable thermostats are used commonly for small spot-warming areas. They are also equipped with a GFCI device.

Note

Never exceed the maximum capacity of the thermostat to heat the floor. If additional power is required, zone with additional programmable thermostats or use a relay contactor.

Floor Sensor

A *floor sensor* is a temperature-monitoring device embedded in the floor and connected to a programmable thermostat. It should be installed in such a way as to give the truest floor temperature. Its installation will also be governed by the type of floor covering.

Many manufacturers will recommend the location of the floor sensor for the different types of floor coverings used with their floor sensor (see Figure 1-35).

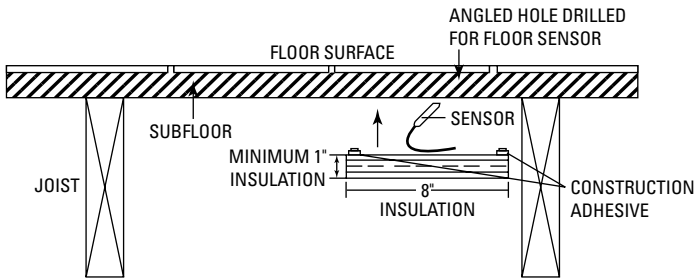

Figure 1-35 Floor sensor installed in angled hole drilled in the bottom of the subfloor. (Courtesy Watts Radiant, Inc.)

Ground Fault Circuit Interrupter

A *ground fault circuit interrupter* (GFCI) is used to monitor the flow of electricity through the heat resistance wire in the mat or roll for any loss of current. If a loss of current is detected, the GFCI immediately cuts off the electricity to the heating system. This is done to prevent damage to the heat resistance wire in the heating mat or roll. The GFCI is an integral part of a programmable thermostat.

An indicating-type GFCI circuit breaker may be installed to serve as a local disconnect. It should be installed near the end of the line close to the thermostat.

Relay Contactor

A *relay contactor* is a device used in conjunction with a single controller to operate the heating in large rooms or spaces. Both single- and double-relay contactors are used in heating systems.

Timer

A *timer* is an optional device used to control when the heating system is turned on and off. It can be used to program 14 events, or two on-off cycles per day for a 2-day or 5-day period. It also can be used in conjunction with a dimmer switch to regulate floor temperature. It cannot moderate the floor temperature.

Dimmer Switch

A *dimmer switch* is a device with an on-off button and a sliding manual control used in some systems to increase or decrease the floor temperature. It can be used in conjunction with a 7-day programmable timer to program a weekly period repetitively.

Installing Electric Heating Mats or Rolls

Electric heating mats or rolls must be installed in accordance with the manufacturer's instructions and any local codes or ordinances.

Before installing the heating mats or rolls, check the shipment to make sure the manufacturer has included everything. If the order is complete, remove the mats or rolls from their boxes and test the ohm resistance of each to make sure it has not been damaged during shipment.

Note

This will be the first of three resistance tests. The second resistance test is performed after the mats have been secured to the subfloor, and the third after the floor covering has been applied over the mats.

To perform a resistance test, set a digital multimeter to the 200-ohms setting and connect the mat lead wires to the multimeter probes. Make sure the resistance reading is within the range of plus 10 percent to minus 5 percent of the resistance rating listed on the mat tag.

An insulation test should be performed to make sure there is no short or ground in the mat or roll. To conduct an insulation test, set the digital multimeter to the megohms setting and connect the silver braid (ground) and black lead to the multimeter probes. The multimeter should read "open" or "OL." Check the instructions with the multimeter to confirm which code represents the "open line." Repeat this test between the silver braid (ground) and the white lead wire.

Caution

The installation of electrical heating systems involves some risk of fire and/or electrical shock that can result in injury or even death. With that in mind, only a qualified, certified electrician or someone with similar training and experience should connect the electric heating mats or rolls to the thermostat and the electrical circuit. Connections should be made in accordance with local codes and ordinances and the provisions in the latest edition of the *National Electrical Code*. The heating mats or rolls must be installed by a qualified contractor or homeowner before the connections to the electrical circuits and control device are made.

Installing Electric Mats or Rolls over Subfloors

Keep a permanent record of the location of the mats or rolls and the floor sensor, if one is installed.

Note

Do not install solid-based furniture, built-in cabinets, bookcases, room dividers, or plumbing fixtures over heating mats or rolls.

The procedure for installing electric heating mats or rolls over a subfloor may be outlined as follows:

1. Use the installation plan provided by the manufacturer to lay the mats or rolls out in the room. This dry run is done to make sure the mats or rolls cover the floor properly (see Figure 1-36).
2. Cut the supporting material (but *not* the heat resistance wire) and turn the mat or roll to fit the dimensions of the room (see Figure 1-37).

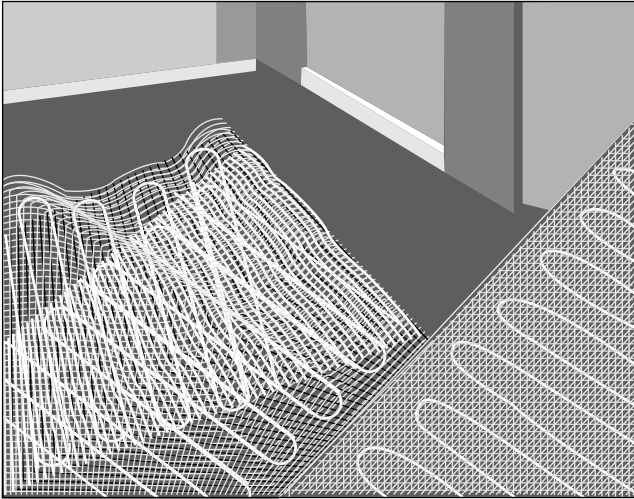

Step 1: Laying the mats on the floor.

Lay the mats out on the floor and "dry" fit them to the dimensions of the room according to the installation plan and the floor markings.

- Do not walk on the heating elements (wires)
- Do not drop tools on the heating element (wire) or strike it with a hammer or tool.
- Place cardboard or carpet sections over the mat and the heating element to protect the latter from damage.

Figure 1-36 Laying the mats or rolls out on the floor.

(Courtesy WarmlyYours.com, Inc.)

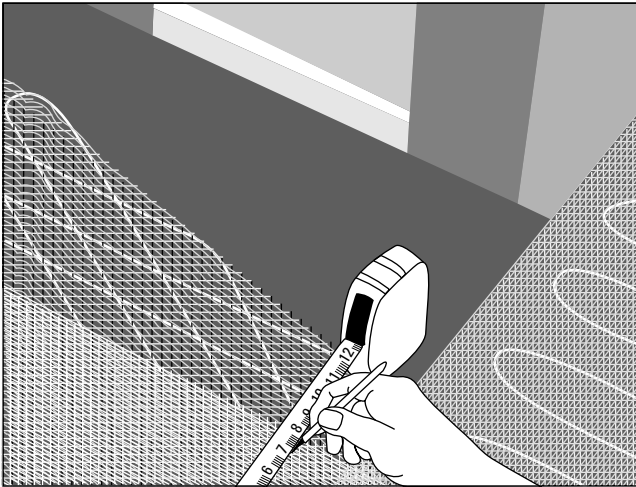

Step 2: Fitting the mats on the floor.

Fit the heating mats (rolls) one panel at a time. Cut and turn the mats according to the installation plan and the floor markings, and then modify the roll into successive and interconnected panels shaped to cover the planned area.

Figure 1-36 (Continued)

3. Glue the mat to the subfloor to prevent it from moving out of position.
4. Test the ohm resistance of each heating roll after it has been secured to the subfloor to make sure it wasn't damaged during installation. *This is the second resistance test.*
5. Cover the roll with a layer of thinset cement. Allow the thinset cement sufficient time to cure. Do *not* turn on the radiant heating system until the thinset cement has cured according to the recommended time on the packaging.
6. Consult the installation plan and mark the approximate location of the heating elements on the cement surface with chalk.
7. Cover the layer of thinset cement with the floor covering (tile, carpet, and so on). Note: Do not nail, screw, or staple near the heating elements and cold lead wires when installing the floor covering. Use the chalk lines as a guide.
8. Test the ohm resistance of the heating rolls to verify that they were not damaged when the floor covering was applied. *This is the third resistance test.*

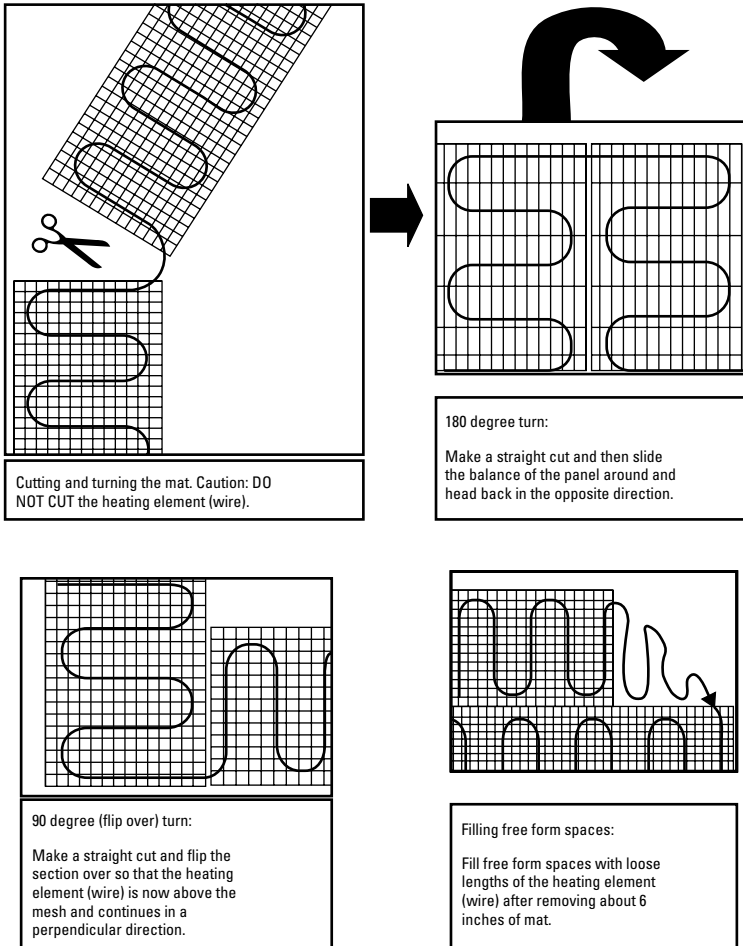

Figure I-37 Turning the mat or roll to fit the dimensions of the room. (Courtesy WarmlyYours.com, Inc.)

9. Hardwire the electric mat or roll to the thermostat. This step should be done only by an electrician or an individual with the required experience of working with electrical systems.

Installing Electric Heating Mats or Rolls in Joist Cavities under Subfloors

Electric heating mats or rolls are also available for use in joist cavities beneath wood subfloors in residential and light commercial construction. The joists are spaced 16 inches on centers.

These mats or rolls may be jointed to fill larger spaces, but they must be wired in parallel (not in series) when joined together. The mats are rated either 120 VAC or 240 VAC. They are wide enough to fit into joist cavities with joists separated 16 inches on center.

The following installation steps are offered only as a guideline. Specific instructions can be obtained from the manufacturer and should be carefully followed.

The procedure for applying electric radiant heating mats or rolls in joist cavities under subfloors may be outlined as follows:

1. Install the floor sensor.
2. Push a length of mat into the joist cavity so that it touches the bottom of the subfloor. The heating wires must be between the supporting mesh and the bottom of the subfloor.
3. Staple one edge of the supporting mesh to the side of the joist. Place the staples a minimum of $\frac{1}{2}$ inch from the heating wire and $\frac{3}{4}$ inch down from the subfloor on the joist.
4. Push the other edge of the mat against the subfloor and nail the mesh to the joist surface. Use the same staple locations. Pull the mat snug against the subfloor as you staple the opposite edge to the joist. There will be a slight droop when you are finished. A gap of not more than 1 inch between the mat and the subfloor is acceptable (see Figure 1-38).
5. Cut the supporting mesh of the mat when it reaches the end of the joist cavity or some other blockage. Do *not* cut the heating wire. Pull the heating wire (without the mesh) down and across a notch cut into the bottom of the floor joist (see Figure 1-39). The notch must not exceed $\frac{1}{4}$ inch in depth and must be covered by a steel nailing plate. Avoid nicking or damaging the heating wire when nailing the plate to the bottom of the joist.

Note

Check the local building codes to see if notching the bottom of the joist for routing the heating wire is permitted. Some codes prohibit notching the joist. Notching the joist is allowed by the BOCA National Building Code (Section 2308.8.2 of the 2000 edition) in each of the one-third ends of a joist span (never in the middle one-third of the span).

6. If notching the joist is not permitted, drill a 2-inch diameter hole through the side of the joist and pull the heating wire *with its supporting mesh* through the hole. Cut away the mesh next to the hole after it has been pulled through.

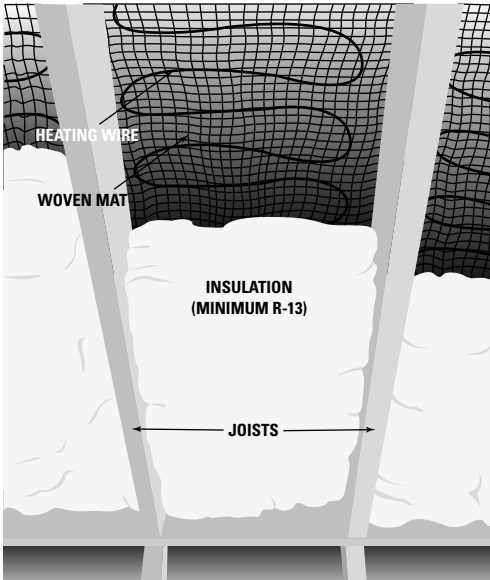

Installation details

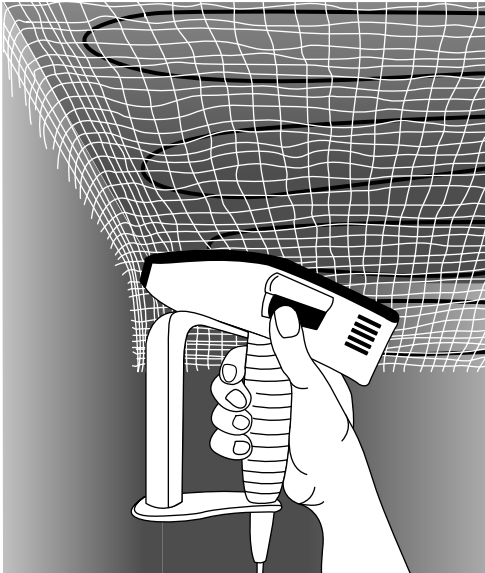

Stapling mat to side of floor joist

Figure I-38 Installing the mat or roll between the joists.

(Courtesy Watts Radiant, Inc.)

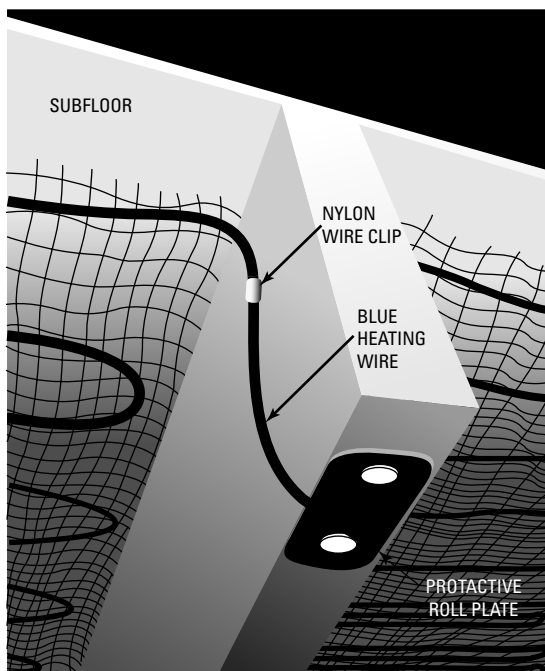

Figure I-39 Extending a heating wire down and around a floor joist. (Courtesy Watts Radiant, Inc.)

7. If a second mat is required to finish out a room area, start the second mat flush with the end of the first mat and wire them in parallel (not series). Do not overlap the mats.
8. Connect the mat leads to the junction box in accordance with the provisions of the local building code or the latest edition of the *National Electrical Code*, if there is no applicable local code. Use additional electrical boxes where required. Connect the floor sensor and power supply.

Caution

Use an experienced and qualified electrician to make these electrical connections. There is always the possibility of severe shock injury, death, and/or property damage if the electrical work is done by inexperienced and unqualified workers.

9. After all the controls have been installed, energize the heating system briefly to see if it is operational.

10. If the system is operating properly, turn off the power and push foil-faced blanket or batt insulation (minimum R-13 rating) into the joist cavities. Leave a clearance of $\frac{1}{2}$ inch to 1 inch between the mat or roll and the insulation (see Figure 1-40).
11. Seal the ends of the joist cavities by installing the last of the insulation vertically. Push the insulation up tight against the subfloor and staple it there so that no heat can escape through the band joists, rim joists, or the open end of a joist cavity.

Installing Electric Cable

Not all electric radiant floor heating systems use mats or rolls to produce the heat. Before mats or rolls became popular, floor systems consisted of coiled electric heating cables. The procedure for installing electric heating cables may be outlined as follows:

1. Make sure the power supply is shut off before beginning any work.
2. Begin the electrical rough-in work by installing the electrical box for the thermostat on the wall.
3. Pull the power supply cable into the thermostat electrical box.
4. Punch out the conduit holes on the box. The heating cable and thermostat sensor leads will be pulled through these electrical box holes later.
5. Lay the cable out on the floor according to the specified coil pattern.
6. Staple the electric cable to the floor through plastic strapping to prevent the coils from moving out of position.
7. Pull the cable and thermostat sensor leads through the punched out conduit holes in the electrical box.
8. Cover the cable with a thin coat of mortar.
9. Allow the mortar a day to dry and then apply the floor covering (for example, carpet, wood flooring).
10. Install the thermostat in the thermostat electrical box.
11. Connect to the power supply.

Note

Only a qualified HVAC technician or someone with an equivalent amount of work experience should be allowed to install an electrical radiant floor heating system. Electricity in inexperienced hands can cause serious injury and even death.

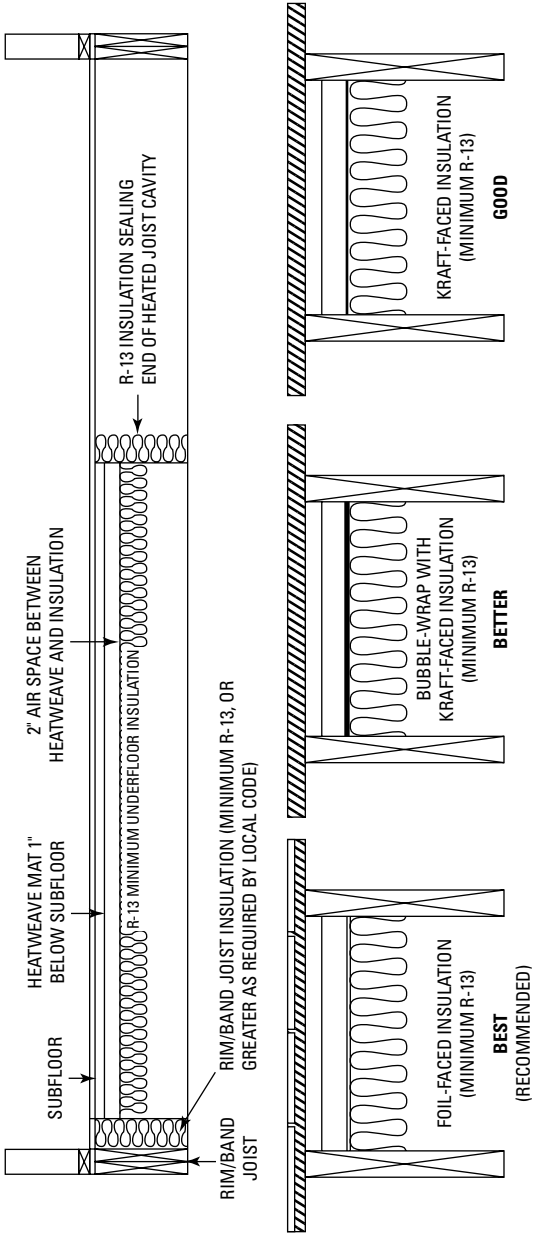

Figure I-40 Installing insulation. (Courtesy Watts Radiant, Inc.)

Servicing and Maintaining an Electric Radiant Floor Heating System

There are no valves, fittings, or moving parts to service or repair in an electric radiant floor heating system. Consequently, there is no need for a maintenance schedule.

Note

Manufacturers provide repair kits with accompanying instructions for repairing mats or rolls damaged at the job site. They do not, however, warranty the repair or ensure proper function of the product following the repair because they have no means of controlling the repair work. Only a qualified electrician should make repairs to mats or rolls.

Caution

Before troubleshooting or repairing an electric heating system, make sure the power is turned off and the mat or roll is disconnected from the power source. Do not cut the heating wire with the mat or roll still connected to the power source.

Note

On rare occasions, a cable in a heating mat may break. When this occurs, it can be easily detected by using an instrument that functions as an underground fault detector. Repairing the break is simply a matter of locating it, removing the small section of floor above it, splicing the cable, and then replacing the flooring. As was already mentioned, the ground fault circuit interrupter is used to monitor electricity flow to determine if there has been any loss of current. If there has been a loss, the thermostat will cut off power to the heating system until the problem is located and corrected. The GFCI on a programmable thermostat should be tested immediately after installing the thermostat, and once a month after the initial test to make sure the GFCI is continuing to operate properly. Testing instructions are provided by the manufacturer of the programmable thermostat.

Troubleshooting Electric Radiant Floor Heating Systems

Caution

Never attempt to service or repair the electric controls inside an electric furnace cabinet unless you have the qualifications and experience to work with electricity. Potentially deadly high-voltage conditions exist inside these furnace cabinets. Refer to Table 1-2.

Table 1-2 Troubleshooting Electric Radiant Floor Heating Systems

<i>Symptom and Possible Cause</i>	<i>Suggested Remedy</i>
No heat.	
(a) Power may be off. Check fuse or circuit breaker panel for blown fuses or tripped breakers.	(a) Replace fuses or reset breakers. If the problem repeats itself, call an electrician or an HVAC technician.
(b) Check thermostat (programmable type) for dead batteries.	(b) Replace batteries and reset thermostat.
Not enough heat.	
(a) Thermostat set too low.	(a) Adjust setting. <i>Note:</i> Thermostats in electric heating systems must be set several degrees higher than the desired room temperature.
(b) Cables require time to heat.	(b) Allow the cables enough time to warm up before changing thermostat setting to a higher one.

Cooling for Hydronic Radiant Floor Systems

Hydronic radiant floor heating systems are capable of providing both heating and cooling independently of air movement. For the heating cycle, hot water is circulated through the pipe coils. For the cooling cycle, cold water (*above* the dew point) is circulated, and the heating cycle is reversed. By keeping the water temperature above 65°F, harmful moisture condensation is avoided.

Radiant panel cooling results only in the removal of sensible heat, and there is sometimes an uncomfortable feeling of dampness. As a result, a separate means of dehumidification is often necessary. Often this can be quite expensive because it may require the installation of a separate dehumidification unit and round flexible air ducts to the various rooms and spaces in the structure.

A common and effective method of cooling a structure equipped with a hydronic radiant floor heating system is to add forced-air cooling. There are several very efficient add-on cooling systems available

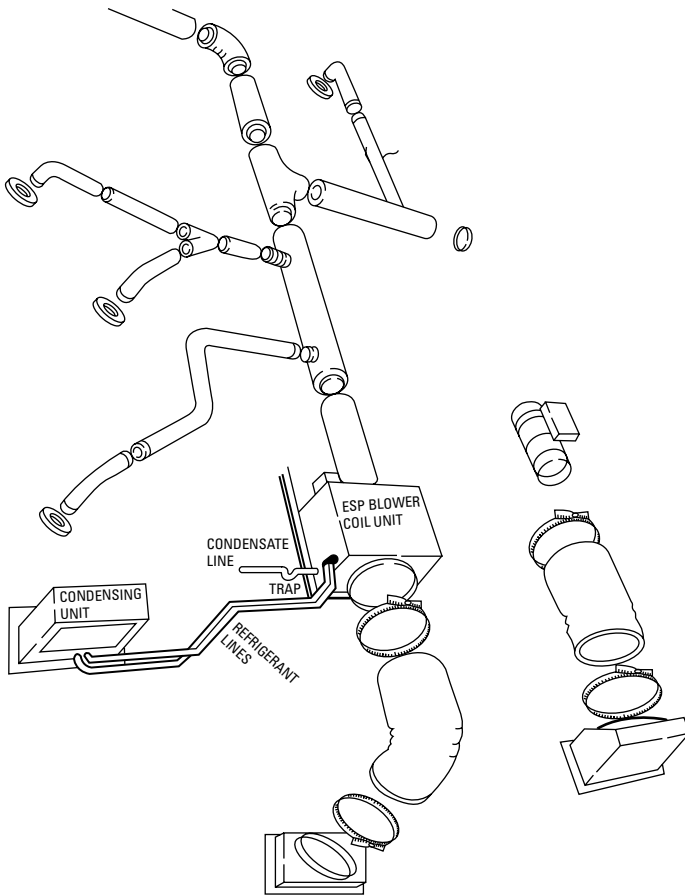

Figure 1-41 Space-Pak air distribution system.

(Courtesy Dunham-Bush, Inc.)

for use with radiant heating. One of the more commonly used ones is the Unico air-conditioning system (see Figure 1-41). It consists of one or more chillers to move the chilled water throughout the house. Air handlers transfer the cold air to the interior rooms and spaces. The cool air travels from the air handler to the rooms and spaces inside the structure through small, round, flexible ducts.

