

## CHAPTER 1

# Introduction to human factors in medicine

### Learning outcomes

By the end of this chapter you should be able to demonstrate an understanding of:

- the historical background to patient safety
- the concept of clinical error
- the range of human factors
- the structure and aims of this text

### Introduction and aims

The aim of this text is to help the reader improve safety in their own practice, in the teams in which they function and in their organisation. This will be achieved by understanding the human factors that contribute to error and exploring ways to prevent, circumvent or minimise these factors by developing awareness and skills.

At the beginning, it is important to state that almost all people in the healthcare professions come to work to do a good job to the best of their ability, not to make a mistake which leads to a clinical error. This book aims to provide healthcare workers with an understanding of the human factors behind clinical error, thus improving their ability to do a good job.

The Department of Health within the UK government have recently highlighted patient safety as a major issue. Many within

---

*Human Factors in the Healthcare Setting: A Pocket Guide for Clinical Instructors*, First Edition. Edited by Peter-Marc Fortune, Mike Davis, Jacky Hanson, and Barbara Phillips.

© 2013 John Wiley & Sons, Ltd. Published 2013 by John Wiley & Sons, Ltd.

healthcare will be aware that patient safety has been an issue throughout medical history.

Patient safety is defined as ‘the freedom from accidental injury due to medical care or from medical error’ (Kohn *et al.* 1999). Medical error, in this book, will be reworded as clinical error – meaning any error that has occurred in the clinical treatment of a patient. This could be caused by anyone involved in clinical care of that patient. Frequently, papers on errors talk about adverse events which are defined as errors from any cause; these may or may not be preventable. An error is any mistake that has occurred; they are specifically defined as clinical (technical) or human (non-technical).

## **Background concepts**

### **Historical background of patient safety**

There has been an awareness of clinical error since Hippocrates’ direction to ‘abstain from harm or wronging any man’. Prior to 1990, however, there was little in the way of literature on clinical error, and initiatives to improve quality of healthcare were sporadic (Vincent 2010). Early improvements to patient safety have been in discoveries of technical skills and systems, with the first examples coming from Semmelweiss (Jarvis 1994), whose published work in 1857 discovered that the introduction of hand disinfection reduced the spread of puerperal fever, and hence mortality. It is interesting that history has repeated itself with the handwashing audits of today, thus a discovery from the 19th century had to be re-emphasised to reduce the spread of hospital-acquired infections. Lister discovered the original concept of the use of antiseptics, but it took until the end of the 19th century for antiseptic techniques to be fully established.

Codman, an American surgeon in the early 1900s, was the first to categorise errors in surgery, culminating in the minimum standards used in the United States until 1952 (Sharpe & Faden 1998). In 1928, maternal morbidity and mortality was investigated in the UK, with national reports produced sporadically until 1952 when the ‘Confidential Enquiry into Maternal Deaths’ was set up, which continues today (CMACE 2011).

The first documentation of adverse events was by Schimmel (1964). He looked at adverse events, excluding clinician error, and found that 20% of patients had at least one adverse event, pointing

out that greater attention was needed to look at clinical risk. His results are similar to those shown in Table 1.1 for the last 20 years. Ivan Illich in 1977 stated that the medical profession had become 'a threat to health'. This was a challenging statement that should alert us to the need to explore patient safety issues and lead to an appreciation of the contribution that human factors make to clinical error.

## Background to clinical error

**Table 1.1** Adverse event incidence in various studies across the world

Country and date	Number of patients reviewed	Number of adverse events	Of the total number of adverse events		
			Number of preventable adverse events	Number of disabled patients	Number of deaths
USA, 1984	30,121	1,200	696	35	163
Australia, 1995	14,179	2,354	1,200	322	115
UK, 2001	1,014	110	53	7	9
UK, 2007	1,006	87	27	13	9

Data from Brennan *et al.* (1991), Wilson *et al.* (1995), Vincent *et al.* (2001) and Sari *et al.* (2007).

The United States was the first country to investigate clinical error systematically. In 1984, Brennan *et al.* looked at 30,121 admissions to New York hospitals and found 1,200 (4%) adverse events overall (Table 1.1). Adverse events were deemed preventable in 58%; 3% of adverse events led to permanent disability and 14% led to death. Extrapolating these figures and others (including the Utah and Colorado figures) to the whole of the USA, there may be between 44,000 and 98,000 Americans dying in hospital per year due to clinical error, at an approximate cost of \$17–29 billion (Kohn *et al.* 1999). This exceeds the mortality rate for breast cancer and severe trauma in the USA.

In Australia, Wilson *et al.* (1995) reviewed 14,179 admissions in New South Wales hospitals and showed an adverse event occurring in 17% of admissions, of which 51% were preventable, 14% caused permanent disability and 5% resulted in death. When extrapolated

to all Australian admissions, this equates to 18,000 deaths per year at an approximate cost of 4.7 billion Australian dollars.

In 2001 in the UK, Vincent *et al.* looked at 1,014 hospital records retrospectively and showed that adverse events had occurred in 11% of patients, 48% of which were from preventable clinical error, producing 6% permanent disability and 8% deaths. This was extrapolated to calculate the cost of extra bed days alone, which was approximately £1 billion. More recently, Sari *et al.* reviewed case notes retrospectively and found 9% of admissions had at least one adverse event, of which 31% were preventable, with 15% of clinical errors producing disability for greater than 6 months and 10% contributing to deaths. They also noted an increased mean length of stay of 8 days associated with error. The report showed that there had been little improvement from 2001 to 2007 (Sari *et al.* 2007).

From the 1980s onwards there was an increase in literature regarding clinical error, and the National Health Service (NHS) started to highlight quality of care, developing systems to improve patient care and safety. McIntyre and Popper (1983) published 'The critical attitude in medicine: the need for a new ethics', encouraging doctors to look for errors and to learn from mistakes. Anaesthetics was the first specialty to start to look at error, notably in systems involving equipment, led by Cooper in 1984. This developed the concept of looking at both psychological and environmental causes, which was furthered during the 1990s, in both anaesthetics and obstetrics, in the USA (Cooper 1994). Gaba and his colleagues advanced this idea, developing crisis resource management in anaesthesiology which provided structure and advocated utilising simulation to practise untoward events. He wrote: 'No industry, in which human life depends on the skilled performance of responsible operators, has waited for unequivocal proof of the benefits of simulation before embracing it,' (Gaba *et al.* 1994).

Leape took this a step further and broadened the concept to include all aspects of medical and nursing care. He discussed the common problem of 'blame culture', which exists in health services, and argued that this had to change. He further maintained that the change would only occur if the medical fraternity accepted that psychology and human factors play a big role in clinical error (Leape 1994). To this end, the UK, USA and other developed countries have made concerns regarding patient safety public. *To Err is Human* was published by the Institute of Medicine in the USA

(Kohn *et al.* 1999), and *An Organisation with a Memory: Learning from Adverse Events in the NHS* (Department of Health 2000) was published in the UK. Both of these documents encouraged learning from other high-risk industries, for example aviation, nuclear and carbon fuels, which have well-developed systems for training and learning from error within their environment.

The House of Commons Health Committee *Report on Patient Safety* in 2009 highlighted 850,000 adverse events reported in the NHS in England, with deaths in 3,500 patients. Concomitant to the increasing statistical evidence for clinical error, there has been growing awareness that clinical error is not only due to error in knowledge or skill (i.e. technical error) but also involves non-technical error, otherwise known as human factors.

The 'Patient Safety First' initiative<sup>1</sup> describes the process of developing a positive safety culture by providing an open and just environment where staff are comfortable discussing safety issues, and are treated fairly if they are involved in an incident. In these circumstances, the development of a reporting culture does not imply blame. The initiative argues that there needs to be a culture open to learning and information sharing, thus enabling all to learn from errors and prevent further episodes.

## Human factors

The Elaine Bromiley case was highlighted in a 'Patient Safety First' document (Carthey *et al.* 2009). She was a fit, young woman who went for a routine ENT operation and the anaesthetist experienced the 'can't intubate, can't ventilate' situation. This developed into a catalogue of errors as attempts to intubate her failed despite emergency equipment being brought in by the nurses, and, tragically, because of a chain of human errors, she never regained consciousness. Elaine Bromiley was married to an airline pilot who could not believe, during the investigation of his wife's death, that medical staff had no training in human factors. He has subsequently become the founder of the Clinical Human Factors Group and was involved in writing the 'Patient Safety First' document. The Department of Health film made with the help of Elaine's

<sup>1</sup><http://www.patientsafetyfirst.nhs.uk/ashx/Asset.ashx?path=/Patient%20Safety%20First%20-%20the%20campaign%20review.pdf> (accessed 25 January 2012).

husband, Martin, is available at [http://www.institute.nhs.uk/safer\\_care/general/human\\_factors.html](http://www.institute.nhs.uk/safer_care/general/human_factors.html). The film is a valuable and powerful introduction to the subject.

### **What are human factors?**

Human factors are systems, behaviours or actions that modify human performance. They can be attributed to the individual, a team of individuals or the way these individuals interact with the working environment. Human factors operate on two levels.

#### ***Level 1: How humans work in a specified system or environment (includes ergonomics)***

Human factors and ergonomics is a discipline in itself and looks at how people interact with systems. It combines looking at human capabilities and the design of systems to maximise safety, performance and ability to work together in harmony. This specialist field was first developed in the Second World War with the development of aviation medicine and psychology. Since then, technology has advanced significantly and so has the field of human factors and ergonomics.<sup>2</sup> It is now multidisciplinary, including psychologists, engineers, IT specialists and physiologists and is essential for any industry that requires man and machine to work together. This subject is not explored in this book but anyone interested can look at Karwowski (2006) for more information.

#### ***Level 2: Non-technical skills, which are cognitive, social and personal***

These specific aspects will be developed in the chapters of this book and include:

- cognition and error
- situation awareness
- leadership and teamwork
- personality and behaviour
- communication and assertiveness
- decision making
- effects on human behaviour: tiredness and fatigue

On an individual level, you will work on the level 2 aspects, which will enable you to understand the interactions with the level 1

<sup>2</sup><http://www.hfes.org/Web/EducationalResources/aboutER.html> (accessed 25 January 2012).

features (specific systems and the environment). These two levels have been shown to relate closely when it comes to errors. It has been shown that an adverse event can be a catalogue of sequential errors which line up with potentially disastrous consequences. This was recognised in James Reason's Swiss cheese model of accident causation (Reason 2000) (Figure 1.1).

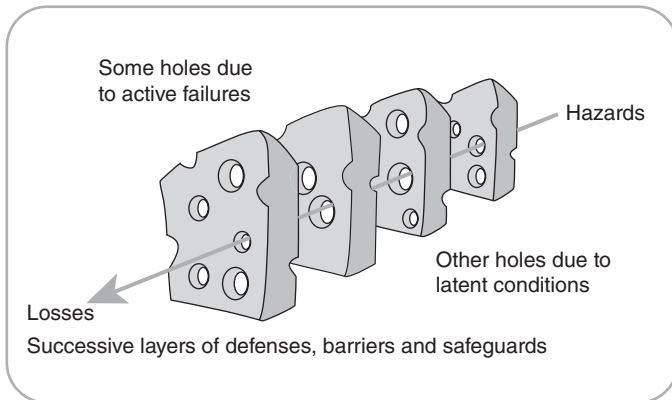

**Figure 1.1** The Swiss cheese model of accident causation (from Reason 2000).

Each of the slices of cheese represents defences/barriers, for example culture, leadership, technical support, training and clinical team membership. These defences would, under ideal circumstances, prevent hazards leading to losses. However, as with all checks and balances, the levels of defence can fail at some stage. This is represented by the holes in the slices. For hazards to be followed by losses, the holes need to line up through all the intervening slices. Simplistically viewed, the more checks that are put in place, the less likely is loss to occur. However, increasing complexity can be counterproductive as humans will avoid or modify multiple steps to make life easier. This produces added problems in the development of latent conditions: poor design, procedures and management decisions, all of which can play a role. Thus, a combination of latent conditions and active human individual errors may lead to an adverse event.

Communication deserves a special mention as problems with communication underpin a significant proportion of reported critical events. The fact that it is vital that clinicians communicate

efficiently and unambiguously in their everyday clinical practice is undeniable. This will be explored fully in Chapter 6.

The book concludes with a short anthology of events from the editors' personal experiences. These are designed to illustrate the reality of some of the issues explored throughout the text. We are sure they are not untypical, and that readers would be able to add similar accounts from their own experiences.

## Summary

The approach of this book is to give an insight into the human factors that affect our ability to care for patients safely and, in doing so, enable the reader to advocate human factor issues in their clinical environment to make caring and working for patients safer.

## References

- Brennan, T.A., Leape L.L., Laird N.M. *et al.* (1991) Incidence of adverse events and negligence in hospitalized patients – results of the Harvard Medical Practice Study I. *New England Journal of Medicine* **324**, 370–6.
- Carthey, J., Clarke, J. & the Clinical Patient Safety Group (2009) *Patient Safety First: The 'How to Guide' for Implementing Human Factors in Healthcare*. Department of Health, The Stationery Office, London.
- CMACE (Centre for Maternal and Child Enquiries (2011) 'Saving Mothers' Lives: reviewing maternal deaths to make motherhood safer: 2006–08.' The Eighth Report on Confidential Enquiries into Maternal Deaths in the United Kingdom. *British Journal of Obstetrics and Gynaecology* **118** (Suppl. 1), 1–203.
- Cooper, J.B. (1994) Towards patient safety in anaesthesia. *Annals of the Academy of Medicine* **23** (4), 552–7.
- Department of Health (2000) *An Organisation with a Memory: Learning from Adverse Events in the NHS*. Department of Health, The Stationery Office, London.
- Gaba, D.M., Fish, K.J. & Howard, S.K. (1994) *Crisis Management in Anesthesiology*. Churchill Livingstone, New York.
- House of Commons Health Committee (2009) *Report on Patient Safety*. Sixth Report of Session 2008–9, vol. 1. House of Commons, The Stationery Office, London.
- Illich, I. (1977) *Limits to Medicine. Medical Nemesis: The Reexploration of Health*. Pelican Books, London.
- Jarvis, W.R. (1994) Hand washing – the Semmelweiss lesson forgotten? *Lancet* **144**, 1311.

- Karwowski, W. (2006) The discipline of ergonomics and human factors. In: Salvendy, G. (ed.) *Handbook of Human Factors and Ergonomics*, 3rd edn, pp. 3–31. John Wiley & Sons, Hoboken, NJ.
- Kohn, L.T., Corrigan, J.M. & Donaldson, M.S. (eds) (1999) *To Err is Human: Building a Safer Healthcare System*. Committee on Quality of Healthcare in America, Institute of Medicine, National Academy Press, Washington.
- Leape, L.L. (1994) Error in medicine. *Journal of the American Medical Association* **272** (23), 1851–7.
- McIntyre, N. & Popper, K. (1983) The critical attitude in medicine: the need for a new ethics. *British Medical Journal* **287**, 1919–23.
- Reason, J. (2000) Human error: models and management. *British Medical Journal* **320** (7237), 768–70.
- Sari, A.B.-A., Sheldon, T.A. & Cracknell, A. (2007) Extent, nature and consequences of adverse events: results of a retrospective case note review in a large NHS hospital. *Quality and Safety in Health Care* **16**, 434–9.
- Schimmel, E.M. (1964) The hazards of hospitalisation. *Annals of Internal Medicine* **60**, 100–10.
- Sharpe, V.A. & Faden, A.I. (1998) *Medical Harm. Historical, Conceptual and Ethical Dimensions of Iatrogenic Illness*. Cambridge University Press, Cambridge.
- Vincent, C. (2010) *Patient Safety*, 2nd edn, pp. 3–30. BMJ Books, Wiley-Blackwell, Oxford.
- Vincent, C., Neale, G. & Woloshynowych, M. (2001) Adverse events in British hospitals: preliminary retrospective record review. *British Medical Journal* **322**, 517–19.
- Wilson, R.M., Runciman, W.B., Gibberd, R.W., Harrison, B.T., Newby, L. & Hamilton, J.D. (1995) The Quality in Australian Health Care Study. *Medical Journal of Australia* **163**, 458–71.