

# CHAPTER 1 *Electric Circuit Variables*

## IN THIS CHAPTER

- |  |  |  |
|--|--|--|
| <b>1.1</b> Introduction                  | <b>1.5</b> Power and Energy            | <b>1.8</b> DESIGN EXAMPLE—Jet Valve Controller |
| <b>1.2</b> Electric Circuits and Current | <b>1.6</b> Circuit Analysis and Design | <b>1.9</b> Summary                             |
| <b>1.3</b> Systems of Units              | <b>1.7</b> How Can We Check . . . ?    | Problems                                       |
| <b>1.4</b> Voltage                       |  | Design Problems                                |

### **1.1** *Introduction*

---

A circuit consists of electrical elements connected together. Engineers use electric circuits to solve problems that are important to modern society. In particular:

1. Electric circuits are used in the generation, transmission, and consumption of electric power and energy.
2. Electric circuits are used in the encoding, decoding, storage, retrieval, transmission, and processing of information.

In this chapter, we will do the following:

- Represent the current and voltage of an electric circuit element, paying particular attention to the reference direction of the current and to the reference direction or polarity of the voltage.
- Calculate the power and energy supplied or received by a circuit element.
- Use the passive convention to determine whether the product of the current and voltage of a circuit element is the power supplied by that element or the power received by the element.
- Use scientific notation to represent electrical quantities with a wide range of magnitudes.

### **1.2** *Electric Circuits and Current*

---

The outstanding characteristics of electricity when compared with other power sources are its mobility and flexibility. Electrical energy can be moved to any point along a couple of wires and, depending on the user's requirements, converted to light, heat, or motion.

An **electric circuit** or electric network is an interconnection of electrical elements linked together in a closed path so that an electric current may flow continuously.

Consider a simple circuit consisting of two well-known electrical elements, a battery and a resistor, as shown in Figure 1.2-1. Each element is represented by the two-terminal element shown in Figure 1.2-2. Elements are sometimes called devices, and terminals are sometimes called nodes.

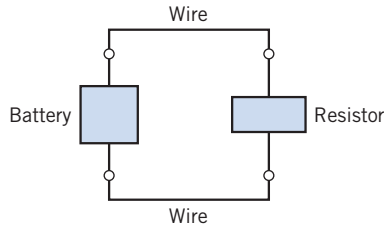

**FIGURE 1.2-1** A simple circuit.



**FIGURE 1.2-2** A general two-terminal electrical element with terminals a and b.

Charge may flow in an electric circuit. *Current is the time rate of change of charge past a given point.* Charge is the intrinsic property of matter responsible for electric phenomena. The quantity of charge  $q$  can be expressed in terms of the charge on one electron, which is  $-1.602 \times 10^{-19}$  coulombs. Thus,  $-1$  coulomb is the charge on  $6.24 \times 10^{18}$  electrons. The current through a specified area is defined by the electric charge passing through the area per unit of time. Thus,  $i$  is defined as the charge expressed in coulombs (C).

**Charge** is the quantity of electricity responsible for electric phenomena.

Then we can express current as

$$i = \frac{dq}{dt} \quad (1.2-1)$$

The unit of current is the ampere (A); an ampere is 1 coulomb per second.

**Current** is the time rate of flow of electric charge past a given point.

Note that throughout this chapter we use a lowercase letter, such as  $q$ , to denote a variable that is a function of time,  $q(t)$ . We use an uppercase letter, such as  $Q$ , to represent a constant.

The flow of current is conventionally represented as a flow of positive charges. This convention was initiated by Benjamin Franklin, the first great American electrical scientist. Of course, we now know that charge flow in metal conductors results from electrons with a negative charge. Nevertheless, we will conceive of current as the flow of positive charge, according to accepted convention.

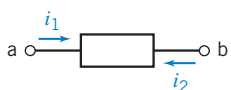

**FIGURE 1.2-3** Current in a circuit element.

Figure 1.2-3 shows the notation that we use to describe a current. There are two parts to this notation: a value (perhaps represented by a variable name) and an assigned direction. As a matter of vocabulary, we say that a current exists *in* or *through* an element. Figure 1.2-3 shows that there are two ways to assign the direction of the current through an element. The current  $i_1$  is the rate of flow of electric charge from terminal a to terminal b. On the other hand, the current  $i_2$  is the flow of electric charge from terminal b to terminal a. The currents  $i_1$  and  $i_2$  are

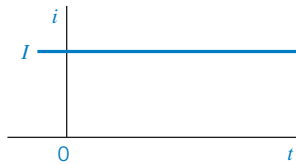

FIGURE 1.2-4 A direct current of magnitude  $I$ .

similar but different. They are the same size but have different directions. Therefore,  $i_2$  is the negative of  $i_1$  and

$$i_1 = -i_2$$

We always associate an arrow with a current to denote its direction. A complete description of current requires both a value (which can be positive or negative) and a direction (indicated by an arrow).

If the current flowing through an element is constant, we represent it by the constant  $I$ , as shown in Figure 1.2-4. A constant current is called a *direct current* (dc).

A **direct current** (dc) is a current of constant magnitude.

A time-varying current  $i(t)$  can take many forms, such as a ramp, a sinusoid, or an exponential, as shown in Figure 1.2-5. The sinusoidal current is called an *alternating current* (ac).

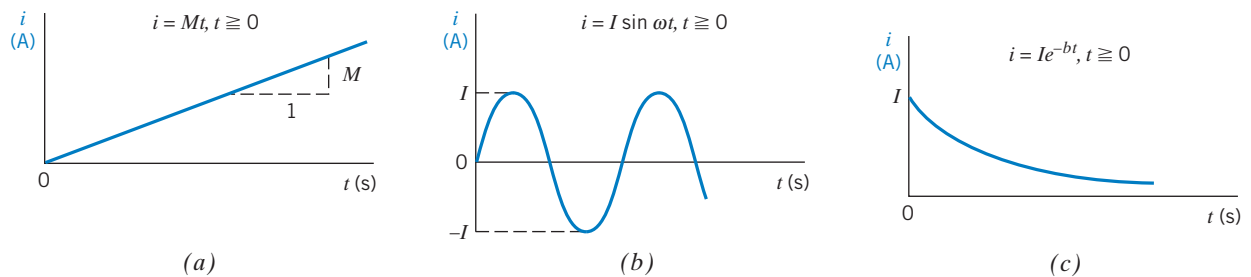

FIGURE 1.2-5 (a) A ramp with a slope  $M$ . (b) A sinusoid. (c) An exponential.  $I$  is a constant. The current  $i$  is zero for  $t < 0$ .

If the charge  $q$  is known, the current  $i$  is readily found using Eq. 1.2-1. Alternatively, if the current  $i$  is known, the charge  $q$  is readily calculated. Note that from Eq. 1.2-1, we obtain

$$q = \int_{-\infty}^t i \, d\tau = \int_0^t i \, d\tau + q(0) \quad (1.2-2)$$

where  $q(0)$  is the charge at  $t = 0$ .

### EXAMPLE 1.2-1 Current from Charge

Find the current in an element when the charge entering the element is

$$q = 12t \text{ C}$$

where  $t$  is the time in seconds.

**Solution**

Recall that the unit of charge is coulombs, C. Then the current, from Eq. 1.2-1, is

$$i = \frac{dq}{dt} = 12 \text{ A}$$

where the unit of current is amperes, A.

**+** Try it yourself  
in WileyPLUS

**EXAMPLE 1.2-2** Charge from Current

Find the charge that has entered the terminal of an element from  $t = 0$  s to  $t = 3$  s when the current entering the element is as shown in Figure 1.2-6.

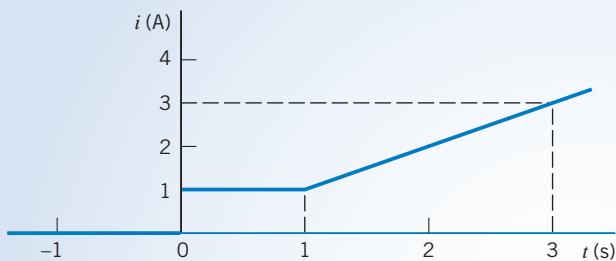

**FIGURE 1.2-6** Current waveform for Example 1.2-2.

**Solution**

From Figure 1.2-6, we can describe  $i(t)$  as

$$i(t) = \begin{cases} 0 & t < 0 \\ 1 & 0 < t \leq 1 \\ t & t > 1 \end{cases}$$

Using Eq. 1.2-2, we have

$$\begin{aligned} q(3) - q(0) &= \int_0^3 i(t) dt = \int_0^1 1 dt + \int_1^3 t dt \\ &= t \Big|_0^1 + \frac{t^2}{2} \Big|_1^3 = 1 + \frac{1}{2}(9 - 1) = 5 \text{ C} \end{aligned}$$

Alternatively, we note that integration of  $i(t)$  from  $t = 0$  to  $t = 3$  s simply requires the calculation of the area under the curve shown in Figure 1.2-6. Then, we have

$$q = 1 + 2 \times 2 = 5 \text{ C}$$

**EXERCISE 1.2-1** Find the charge that has entered an element by time  $t$  when  $i = 8t^2 - 4t$  A,  $t \geq 0$ . Assume  $q(t) = 0$  for  $t < 0$ .

**Answer:**  $q(t) = \frac{8}{3}t^3 - 2t^2$  C

**EXERCISE 1.2-2** The total charge that has entered a circuit element is  $q(t) = 4 \sin 3t$  C when  $t \geq 0$ , and  $q(t) = 0$  when  $t < 0$ . Determine the current in this circuit element for  $t > 0$ .

**Answer:**  $i(t) = \frac{d}{dt} 4 \sin 3t = 12 \cos 3t$  A

### 1.3 Systems of Units

In representing a circuit and its elements, we must define a consistent system of units for the quantities occurring in the circuit. At the 1960 meeting of the General Conference of Weights and Measures, the representatives modernized the metric system and created the *Système International d'Unités*, commonly called SI units.

**SI** is *Système International d'Unités* or the International System of Units.

The fundamental, or base, units of SI are shown in Table 1.3-1. Symbols for units that represent proper (persons') names are capitalized; the others are not. Periods are not used after the symbols, and the symbols do not take on plural forms. The derived units for other physical quantities are obtained by combining the fundamental units. Table 1.3-2 shows the more common derived units along with their formulas in terms of the fundamental units or preceding derived units. Symbols are shown for the units that have them.

**Table 1.3-1 SI Base Units**

QUANTITY	SI UNIT	
	NAME	SYMBOL
Length	meter	m
Mass	kilogram	kg
Time	second	s
Electric current	ampere	A
Thermodynamic temperature	kelvin	K
Amount of substance	mole	mol
Luminous intensity	candela	cd

**Table 1.3-2 Derived Units in SI**

QUANTITY	UNIT NAME	FORMULA	SYMBOL
Acceleration — linear	meter per second per second	$m/s^2$	
Velocity — linear	meter per second	$m/s$	
Frequency	hertz	$s^{-1}$	Hz
Force	newton	$kg \cdot m/s^2$	N
Pressure or stress	pascal	$N/m^2$	Pa
Density	kilogram per cubic meter	$kg/m^3$	
Energy or work	joule	$N \cdot m$	J
Power	watt	$J/s$	W
Electric charge	coulomb	$A \cdot s$	C
Electric potential	volt	$W/A$	V
Electric resistance	ohm	$V/A$	$\Omega$
Electric conductance	siemens	$A/V$	S
Electric capacitance	farad	$C/V$	F
Magnetic flux	weber	$V \cdot s$	Wb
Inductance	henry	$Wb/A$	H

**Table 1.3-3 SI Prefixes**

MULTIPLE	PREFIX	SYMBOL
$10^{12}$	tera	T
$10^9$	giga	G
$10^6$	mega	M
$10^3$	kilo	k
$10^{-2}$	centi	c
$10^{-3}$	milli	m
$10^{-6}$	micro	$\mu$
$10^{-9}$	nano	n
$10^{-12}$	pico	p
$10^{-15}$	femto	f

The basic units such as length in meters (m), time in seconds (s), and current in amperes (A) can be used to obtain the derived units. Then, for example, we have the unit for charge (C) derived from the product of current and time (A · s). The fundamental unit for energy is the joule (J), which is force times distance or N · m.

The great advantage of the SI system is that it incorporates a decimal system for relating larger or smaller quantities to the basic unit. The powers of 10 are represented by standard prefixes given in Table 1.3-3. An example of the common use of a prefix is the centimeter (cm), which is 0.01 meter.

The decimal multiplier must always accompany the appropriate units and is never written by itself. Thus, we may write 2500 W as 2.5 kW. Similarly, we write 0.012 A as 12 mA.

### EXAMPLE 1.3-1 SI Units

A mass of 150 grams experiences a force of 100 newtons. Find the energy or work expended if the mass moves 10 centimeters. Also, find the power if the mass completes its move in 1 millisecond.

#### Solution

The energy is found as

$$\text{energy} = \text{force} \times \text{distance} = 100 \times 0.1 = 10 \text{ J}$$

Note that we used the distance in units of meters. The power is found from

$$\text{power} = \frac{\text{energy}}{\text{time period}}$$

where the time period is  $10^{-3}$  s. Thus,

$$\text{power} = \frac{10}{10^{-3}} = 10^4 \text{ W} = 10 \text{ kW}$$

**EXERCISE 1.3-1** Which of the three currents,  $i_1 = 45 \mu\text{A}$ ,  $i_2 = 0.03 \text{ mA}$ , and  $i_3 = 25 \times 10^{-4} \text{ A}$ , is largest?

**Answer:**  $i_3$  is largest.

## 1.4 Voltage

The basic variables in an electrical circuit are current and voltage. These variables describe the flow of charge through the elements of a circuit and the energy required to cause charge to flow. Figure 1.4-1 shows the notation we use to describe a voltage. There are two parts to this notation: a value (perhaps represented by a variable name) and an assigned direction. The value of a voltage may be positive or negative. The direction of a voltage is given by its polarities (+, −). As a matter of vocabulary, we say that a voltage exists *across* an element. Figure 1.4-1 shows that there are two ways to label the voltage across an element. The voltage  $v_{ba}$  is proportional to the work required to move a positive charge from terminal a to terminal b. On the other hand, the voltage  $v_{ab}$  is proportional to the work required to move a positive charge from terminal b to terminal a. We sometimes read  $v_{ba}$  as “the voltage at terminal b with respect to terminal a.” Similarly,  $v_{ab}$  can be read as “the voltage at terminal a with respect to terminal b.” Alternatively, we sometimes say that  $v_{ba}$  is the voltage drop from terminal a to terminal b. The voltages  $v_{ab}$  and  $v_{ba}$  are similar but different. They have the same magnitude but different polarities. This means that

$$v_{ab} = -v_{ba}$$

When considering  $v_{ba}$ , terminal b is called the “+ terminal” and terminal a is called the “− terminal.” On the other hand, when talking about  $v_{ab}$ , terminal a is called the “+ terminal” and terminal b is called the “− terminal.”

The **voltage** across an element is the work (energy) required to move a unit positive charge from the − terminal to the + terminal. The unit of voltage is the volt, V.

The equation for the voltage across the element is

$$v = \frac{dw}{dq} \quad (1.4-1)$$

where  $v$  is voltage,  $w$  is energy (or work), and  $q$  is charge. A charge of 1 coulomb delivers an energy of 1 joule as it moves through a voltage of 1 volt.

## 1.5 Power and Energy

The power and energy delivered to an element are of great importance. For example, the useful output of an electric lightbulb can be expressed in terms of power. We know that a 300-watt bulb delivers more light than a 100-watt bulb.

**Power** is the time rate of supplying or receiving power.

Thus, we have the equation

$$p = \frac{dw}{dt} \quad (1.5-1)$$

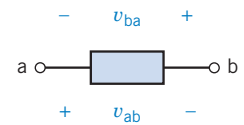

**FIGURE 1.4-1** Voltage across a circuit element.

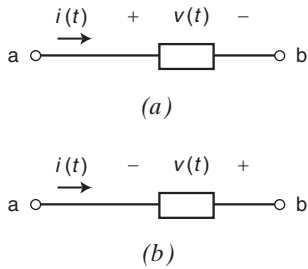

**FIGURE 1.5-1** (a) The element voltage and current **adhere** to the passive convention. (b) The element voltage and current **do not adhere** to the passive convention.

where  $p$  is power in watts,  $w$  is energy in joules, and  $t$  is time in seconds. The power associated with the current through an element is

$$p = \frac{dw}{dt} = \frac{dw}{dq} \cdot \frac{dq}{dt} = v \cdot i \quad (1.5-2)$$

From Eq. 1.5-2, we see that the power is simply the product of the voltage across an element times the current through the element. The power has units of watts.

Two circuit variables are assigned to each element of a circuit: a voltage and a current. Figure 1.5-1 shows that there are two different ways to arrange the direction of the current and the polarity of the voltage. In Figure 1.5-1a, the current is directed from the + toward the – of the voltage polarity. In contrast, in Figure 1.5-1b, the current is directed from the – toward the + of the voltage polarity.

First, consider Figure 1.5-1a. When the current enters the circuit element at the + terminal of the voltage and exits at the – terminal, the voltage and current are said to “adhere to the passive convention.” In the passive convention, the voltage pushes a positive charge in the direction indicated by the current. Accordingly, the power calculated by multiplying the element voltage by the element current

$$p = vi$$

is the power **received** by the element. (This power is sometimes called “the power absorbed by the element” or “the power dissipated by the element.”) The power received by an element can be either positive or negative. This will depend on the values of the element voltage and current.

Next, consider Figure 1.5-1b. Here the passive convention has not been used. Instead, the current enters the circuit element at the – terminal of the voltage and exits at the + terminal. In this case, the voltage pushes a positive charge in the direction opposite to the direction indicated by the current. Accordingly, when the element voltage and current do not adhere to the passive convention, the power calculated by multiplying the element voltage by the element current is the power **supplied** by the element. The power supplied by an element can be either positive or negative, depending on the values of the element voltage and current.

The power received by an element and the power supplied by that same element are related by

$$\text{power received} = -\text{power supplied}$$

The rules for the passive convention are summarized in Table 1.5-1. When the element voltage and current adhere to the passive convention, the energy received by an element can be determined

**Table 1.5-1** Power Received or Supplied by an Element

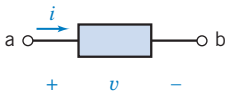
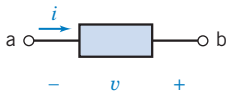
POWER RECEIVED BY AN ELEMENT	POWER SUPPLIED BY AN ELEMENT
 <p>Because the reference directions of <math>v</math> and <math>i</math> adhere to the passive convention, the power</p> $p = vi$ <p>is the power received by the element.</p>	 <p>Because the reference directions of <math>v</math> and <math>i</math> do not adhere to the passive convention, the power</p> $p = vi$ <p>is the power supplied by the element.</p>

from Eq. 1.5-1 by rewriting it as

$$dw = p dt \quad (1.5-3)$$

On integrating, we have

$$w = \int_{-\infty}^t p d\tau \quad (1.5-4)$$

If the element only receives power for  $t \geq t_0$  and we let  $t_0 = 0$ , then we have

$$w = \int_0^t p d\tau \quad (1.5-5)$$

### EXAMPLE 1.5-1 Electrical Power and Energy

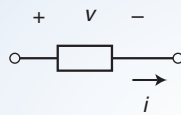

FIGURE 1.5-2 The element considered in Example 1.5-1.

Let us consider the element shown in Figure 1.5-2 when  $v = 8 \text{ V}$  and  $i = 25 \text{ mA}$ . Find the power received by the element and the energy received during a 10-ms interval.

#### Solution

In Figure 1.5-2 the current  $i$  and voltage  $v$  adhere to the passive convention. Consequently the power

$$p = vi = 8(0.025) = 0.2 \text{ W} = 200 \text{ mW}$$

is the power *received* by the circuit element. Next, the energy received by the element is

$$w = \int_0^t p dt = \int_0^{0.010} 0.2 dt = 0.2(0.010) = 0.002 \text{ J} = 2 \text{ mJ}$$

### EXAMPLE 1.5-2 Electrical Power and the Passive Convention

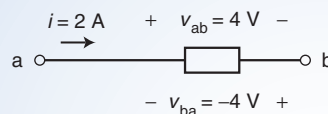

FIGURE 1.5-3 The element considered in Example 1.5-2.

Consider the element shown in Figure 1.5-3. The current  $i$  and voltage  $v_{ab}$  adhere to the passive convention, so

$$i \cdot v_{ab} = 2 \cdot (-4) = -8 \text{ W}$$

is the power *received* by this element. The current  $i$  and voltage  $v_{ba}$  do not adhere to the passive convention, so

$$i \cdot v_{ba} = 2 \cdot (4) = 8 \text{ W}$$

is the power *supplied* by this element. As expected

$$\text{power received} = -\text{power supplied}$$



### EXAMPLE 1.5-3 Power, Energy, and the Passive Convention

Consider the circuit shown in Figure 1.5-4 with  $v(t) = 12e^{-8t}$  V and  $i(t) = 5e^{-8t}$  A for  $t \geq 0$ . Both  $v(t)$  and  $i(t)$  are zero for  $t < 0$ . Find the power supplied by this element and the energy supplied by the element over the first 100 ms of operation.

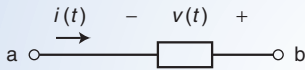

FIGURE 1.5-4 The element considered in Example 1.5-3.

#### Solution

The power

$$p(t) = v(t) i(t) = (12e^{-8t})(5e^{-8t}) = 60e^{-16t} \text{ W}$$

is the power *supplied* by the element because  $v(t)$  and  $i(t)$  do not adhere to the passive convention. This element is supplying power to the charge flowing through it.

The energy supplied during the first 100 ms = 0.1 seconds is

$$\begin{aligned} w(0.1) &= \int_0^{0.1} p \, dt = \int_0^{0.1} (60e^{-16t}) \, dt \\ &= 60 \left. \frac{e^{-16t}}{-16} \right|_0^{0.1} = -\frac{60}{16} (e^{-1.6} - 1) = 3.75(1 - e^{-1.6}) = 2.99 \text{ J} \end{aligned}$$

### EXAMPLE 1.5-4 Energy in a Thunderbolt

The average current in a typical lightning thunderbolt is  $2 \times 10^4$  A, and its typical duration is 0.1 s (Williams, 1988). The voltage between the clouds and the ground is  $5 \times 10^8$  V. Determine the total charge transmitted to the earth and the energy released.

#### Solution

The total charge is

$$Q = \int_0^{0.1} i(t) \, dt = \int_0^{0.1} 2 \times 10^4 \, dt = 2 \times 10^3 \text{ C}$$

The total energy released is

$$w = \int_0^{0.1} i(t) \times v(t) \, dt = \int_0^{0.1} (2 \times 10^4)(5 \times 10^8) \, dt = 10^{12} \text{ J} = 1 \text{ TJ}$$

**EXERCISE 1.5-1** Figure E 1.5-1 shows four circuit elements identified by the letters A, B, C, and D.

- Which of the devices supply 12 W?
- Which of the devices absorb 12 W?

- (c) What is the value of the power received by device *B*?  
 (d) What is the value of the power delivered by device *B*?  
 (e) What is the value of the power delivered by device *D*?

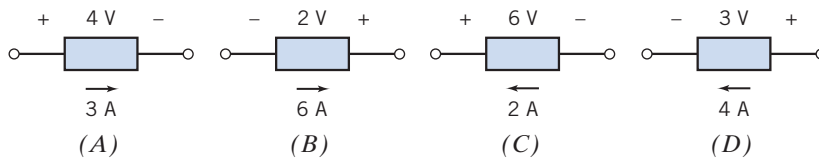

FIGURE E 1.5-1

**Answers:** (a) *B* and *C*, (b) *A* and *D*, (c)  $-12\text{ W}$ , (d)  $12\text{ W}$ , (e)  $-12\text{ W}$

## 1.6 Circuit Analysis and Design

The analysis and design of electric circuits are the primary activities described in this book and are key skills for an electrical engineer. The *analysis* of a circuit is concerned with the methodical study of a given circuit designed to obtain the magnitude and direction of one or more circuit variables, such as a current or voltage.

The analysis process begins with a statement of the problem and usually includes a given circuit model. The goal is to determine the magnitude and direction of one or more circuit variables, and the final task is to verify that the proposed solution is indeed correct. Usually, the engineer first identifies what is known and the principles that will be used to determine the unknown variable.

The problem-solving method that will be used throughout this book is shown in Figure 1.6-1. Generally, the problem statement is given. The analysis process then moves sequentially through the five steps shown in Figure 1.6-1. First, we describe the situation and the assumptions. We also record or review the circuit model that is provided. Second, we state the goals and requirements, and we

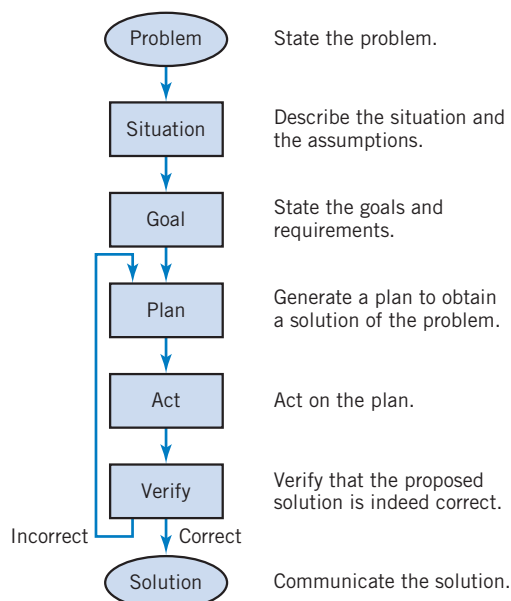

FIGURE 1.6-1 The problem-solving method.

normally record the required circuit variable to be determined. The third step is to create a plan that will help obtain the solution of the problem. Typically, we record the principles and techniques that pertain to this problem. The fourth step is to act on the plan and carry out the steps described in the plan. The final step is to verify that the proposed solution is indeed correct. If it is correct, we communicate this solution by recording it in writing or by presenting it verbally. If the verification step indicates that the proposed solution is incorrect or inadequate, then we return to the plan steps, reformulate an improved plan, and repeat steps 4 and 5.

To illustrate this analytical method, we will consider an example. In Example 1.6-1, we use the steps described in the problem-solving method of Figure 1.6-1.

### EXAMPLE 1.6-1 The Formal Problem-Solving Method

An experimenter in a lab assumes that an element is absorbing power and uses a voltmeter and ammeter to measure the voltage and current as shown in Figure 1.6-2. The measurements indicate that the voltage is  $v = +12\text{ V}$  and the current is  $i = -2\text{ A}$ . Determine whether the experimenter's assumption is correct.

**Describe the Situation and the Assumptions:** Strictly speaking, the element *is* absorbing power. The value of the power absorbed by the element may be positive or zero or negative. When we say that someone “assumes that an element is absorbing power,” we mean that someone assumes that the power absorbed by the element is positive.

The meters are ideal. These meters have been connected to the element in such a way as to measure the voltage labeled  $v$  and the current labeled  $i$ . The values of the voltage and current are given by the meter readings.

**State the Goals:** Calculate the power absorbed by the element to determine whether the value of the power absorbed is positive.

**Generate a Plan:** Verify that the element voltage and current adhere to the passive convention. If so, the power absorbed by the device is  $p = vi$ . If not, the power absorbed by the device is  $p = -vi$ .

**Act on the Plan:** Referring to Table 1.5-1, we see that the element voltage and current do adhere to the passive convention. Therefore, power absorbed by the element is

$$p = vi = 12 \cdot (-2) = -24\text{ W}$$

The value of the power absorbed is not positive.

**Verify the Proposed Solution:** Let's reverse the ammeter probes as shown in Figure 1.6-3. Now the ammeter measures the current  $i_1$  rather than the current  $i$ , so  $i_1 = 2\text{ A}$  and  $v = 12\text{ V}$ . Because  $i_1$  and  $v$  do not adhere to the passive convention,  $p = i_1 \cdot v = 24\text{ W}$  is the power supplied by the element. Supplying  $24\text{ W}$  is equivalent to absorbing  $-24\text{ W}$ , thus verifying the proposed solution.

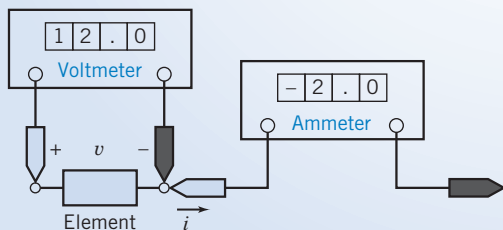

FIGURE 1.6-2 An element with a voltmeter and ammeter.

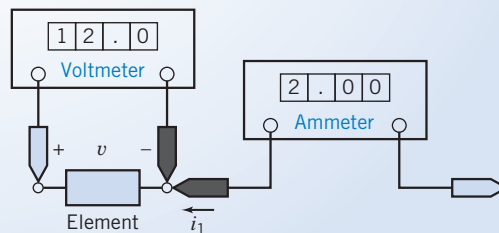

FIGURE 1.6-3 The circuit from Figure 1.6-2 with the ammeter probes reversed.

*Design* is a purposeful activity in which a designer visualizes a desired outcome. It is the process of originating circuits and predicting how these circuits will fulfill objectives. Engineering design is the process of producing a set of descriptions of a circuit that satisfy a set of performance requirements and constraints.

The design process may incorporate three phases: analysis, synthesis, and evaluation. The first task is to diagnose, define, and prepare—that is, to understand the problem and produce an explicit statement of goals; the second task involves finding plausible solutions; the third concerns judging the validity of solutions relative to the goals and selecting among alternatives. A cycle is implied in which the solution is revised and improved by reexamining the analysis. These three phases are part of a framework for planning, organizing, and evolving design projects.

**Design** is the process of creating a circuit to satisfy a set of goals.

The problem-solving process shown in Figure 1.6-1 is used in Design Examples included in each chapter.

## 1.7 How Can We Check . . . ?

Engineers are frequently called upon to check that a solution to a problem is indeed correct. For example, proposed solutions to design problems must be checked to confirm that all of the specifications have been satisfied. In addition, computer output must be reviewed to guard against data-entry errors, and claims made by vendors must be examined critically.

Engineering students are also asked to check the correctness of their work. For example, occasionally just a little time remains at the end of an exam. It is useful to be able quickly to identify those solutions that need more work.

This text includes some examples that illustrate techniques useful for checking the solutions of the particular problems discussed in that chapter. At the end of each chapter, some problems are presented that provide an opportunity to practice these techniques.

### EXAMPLE 1.7-1 How Can We Check Power and the Passive Convention?

A laboratory report states that the measured values of  $v$  and  $i$  for the circuit element shown in Figure 1.7-1 are  $-5$  V and  $2$  A, respectively. The report also states that the power absorbed by the element is  $10$  W. **How can we check** the reported value of the power absorbed by this element?

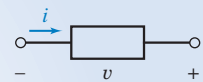

**FIGURE 1.7-1** A circuit element with measured voltage and current.

#### Solution

Does the circuit element absorb  $-10$  W or  $+10$  W? The voltage and current shown in Figure 1.7-1 do not adhere to the passive sign convention. Referring to Table 1.5-1, we see that the product of this voltage and current is the power supplied by the element rather than the power absorbed by the element.

Then the power supplied by the element is

$$p = vi = (-5)(2) = -10 \text{ W}$$

The power absorbed and the power supplied by an element have the same magnitude but the opposite sign. Thus, we have verified that the circuit element is indeed absorbing  $10$  W.

## 1.8 DESIGN EXAMPLE Jet Valve Controller

A small, experimental space rocket uses a two-element circuit, as shown in Figure 1.8-1, to control a jet valve from point of liftoff at  $t=0$  until expiration of the rocket after one minute. The energy that must be supplied by element 1 for the one-minute period is 40 mJ. Element 1 is a battery to be selected.

It is known that  $i(t) = De^{-t/60}$  mA for  $t \geq 0$ , and the voltage across the second element is  $v_2(t) = Be^{-t/60}$  V for  $t \geq 0$ . The maximum magnitude of the current,  $D$ , is limited to 1 mA. Determine the required constants  $D$  and  $B$  and describe the required battery.

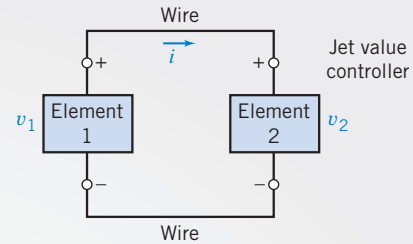

**FIGURE 1.8-1** The circuit to control a jet valve for a space rocket.

### Describe the Situation and the Assumptions

1. The current enters the plus terminal of the second element.
2. The current leaves the plus terminal of the first element.
3. The wires are perfect and have no effect on the circuit (they do not absorb energy).
4. The model of the circuit, as shown in Figure 1.8-1, assumes that the voltage across the two elements is equal; that is,  $v_1 = v_2$ .
5. The battery voltage  $v_1$  is  $v_1 = Be^{-t/60}$  V where  $B$  is the initial voltage of the battery that will discharge exponentially as it supplies energy to the valve.
6. The circuit operates from  $t = 0$  to  $t = 60$  s.
7. The current is limited, so  $D \leq 1$  mA.

### State the Goal

Determine the energy supplied by the first element for the one-minute period and then select the constants  $D$  and  $B$ . Describe the battery selected.

### Generate a Plan

First, find  $v_1(t)$  and  $i(t)$  and then obtain the power,  $p_1(t)$ , supplied by the first element. Next, using  $p_1(t)$ , find the energy supplied for the first 60 s.

GOAL	EQUATION	NEED	INFORMATION
The energy $w_1$ for the first 60 s	$w_1 = \int_0^{60} p_1(t) dt$	$p_1(t)$	$v_1$ and $i$ known except for constants $D$ and $B$

### Act on the Plan

First, we need  $p_1(t)$ , so we first calculate

$$\begin{aligned} p_1(t) &= iv_1 = (De^{-t/60} \times 10^{-3} \text{ A})(Be^{-t/60} \text{ V}) \\ &= DBe^{-t/30} \times 10^{-3} \text{ W} = DBe^{-t/30} \text{ mW} \end{aligned}$$

Second, we need to find  $w_1$  for the first 60 s as

$$\begin{aligned} w_1 &= \int_0^{60} (DBe^{-t/30} \times 10^{-3}) dt = \frac{DB \times 10^{-3} e^{-t/30}}{-1/30} \Big|_0^{60} \\ &= -30DB \times 10^{-3} (e^{-2} - 1) = 25.9DB \times 10^{-3} \text{ J} \end{aligned}$$

Because we require  $w_1 \geq 40$  mJ,

$$40 \leq 25.9DB$$

Next, select the limiting value,  $D = 1$ , to get

$$B \geq \frac{40}{(25.9)(1)} = 1.54 \text{ V}$$

Thus, we select a 2-V battery so that the magnitude of the current is less than 1 mA.

### Verify the Proposed Solution

We must verify that at least 40 mJ is supplied using the 2-V battery. Because  $i = e^{-t/60}$  mA and  $v_2 = 2e^{-t/60}$  V, the energy supplied by the battery is

$$w = \int_0^{60} (2e^{-t/60})(e^{-t/60} \times 10^{-3}) dt = \int_0^{60} 2e^{-t/30} \times 10^{-3} dt = 51.8 \text{ mJ}$$

Thus, we have verified the solution, and we communicate it by recording the requirement for a 2-V battery.

## 1.9 SUMMARY

- Charge is the intrinsic property of matter responsible for electric phenomena. The current in a circuit element is the rate of movement of charge through the element. The voltage across an element indicates the energy available to cause charge to move through the element.
- Given the current,  $i$ , and voltage,  $v$ , of a circuit element, the power,  $p$ , and energy,  $w$ , are given by
- Table 1.5-1 summarizes the use of the passive convention when calculating the power supplied or received by a circuit element.
- The SI units (Table 1.3-1) are used by today's engineers and scientists. Using decimal prefixes (Table 1.3-3), we may simply express electrical quantities with a wide range of magnitudes.

$$p = v \cdot i \quad \text{and} \quad w = \int_0^t p d\tau$$

## PROBLEMS

⊕ Problem available in WileyPLUS at instructor's discretion.

### Section 1.2 Electric Circuits and Current

**P 1.2-1** ⊕ The total charge that has entered a circuit element is  $q(t) = 1.25(1 - e^{-5t})$  when  $t \geq 0$  and  $q(t) = 0$  when  $t < 0$ . Determine the current in this circuit element for  $t \geq 0$ .

**Answer:**  $i(t) = 6.25e^{-5t}$  A

**P 1.2-2** ⊕ The current in a circuit element is  $i(t) = 4(1 - e^{-5t})$  A when  $t \geq 0$  and  $i(t) = 0$  when  $t < 0$ . Determine the total charge that has entered a circuit element for  $t \geq 0$ .

**Hint:**  $q(0) = \int_{-\infty}^0 i(\tau) d\tau = \int_{-\infty}^0 0 d\tau = 0$

**Answer:**  $q(t) = 4t + 0.8e^{-5t} - 0.8$  C for  $t \geq 0$

**P 1.2-3** ⊕ The current in a circuit element is  $i(t) = 4 \sin 5t$  A when  $t \geq 0$  and  $i(t) = 0$  when  $t < 0$ . Determine the total charge that has entered a circuit element for  $t \geq 0$ .

**Hint:**  $q(0) = \int_{-\infty}^0 i(\tau) d\tau = \int_{-\infty}^0 0 d\tau = 0$

**P 1.2-4** The current in a circuit element is

$$i(t) = \begin{cases} 0 & t < 2 \\ 2 & 2 < t < 4 \\ -1 & 4 < t < 8 \\ 0 & 8 < t \end{cases}$$

where the units of current are A and the units of time are s. Determine the total charge that has entered a circuit element for  $t \geq 0$ .

**Answer:**

$$q(t) = \begin{cases} 0 & t < 2 \\ 2t - 4 & 2 < t < 4 \\ 8 - t & 4 < t < 8 \\ 0 & 8 < t \end{cases} \quad \text{where the units of}$$

charge are C.

**P 1.2-5** The total charge  $q(t)$ , in coulombs, that enters the terminal of an element is

$$q(t) = \begin{cases} 0 & t < 0 \\ 2t & 0 \leq t \leq 2 \\ 3 + e^{-2(t-2)} & t > 2 \end{cases}$$

Find the current  $i(t)$  and sketch its waveform for  $t \geq 0$ .

**P 1.2-6** An electroplating bath, as shown in Figure P 1.2-6, is used to plate silver uniformly onto objects such as kitchenware and plates. A current of 450 A flows for 20 minutes, and each coulomb transports 1.118 mg of silver. What is the weight of silver deposited in grams?

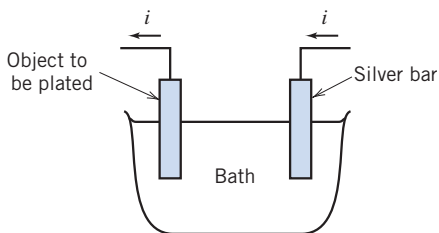

**Figure P 1.2-6** An electroplating bath.

**P 1.2-7** Find the charge  $q(t)$  and sketch its waveform when the current entering a terminal of an element is as shown in Figure P 1.2-7. Assume that  $q(t) = 0$  for  $t < 0$ .

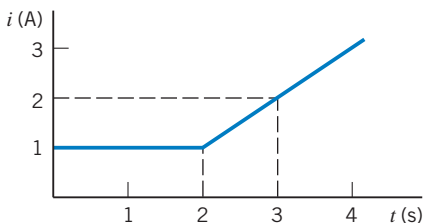

**Figure P 1.2-7**

### Section 1.3 Systems of Units

**P 1.3-1** A constant current of  $3.2 \mu\text{A}$  flows through an element. What is the charge that has passed through the element in the first millisecond?

**Answer:**  $3.2 \text{ nC}$

**P 1.3-2** A charge of  $45 \text{ nC}$  passes through a circuit element during a particular interval of time that is  $5 \text{ ms}$  in duration. Determine the average current in this circuit element during that interval of time.

**Answer:**  $i = 9 \mu\text{A}$

**P 1.3-3** Ten billion electrons per second pass through a particular circuit element. What is the average current in that circuit element?

**Answer:**  $i = 1.602 \text{ nA}$

**P 1.3-4** The charge flowing in a wire is plotted in Figure P 1.3-4. Sketch the corresponding current.

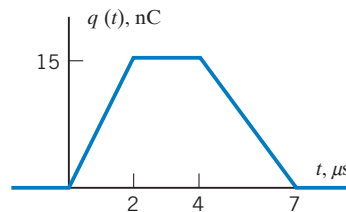

**Figure P 1.3-4**

**P 1.3-5** The current in a circuit element is plotted in Figure P 1.3-5. Sketch the corresponding charge flowing through the element for  $t > 0$ .

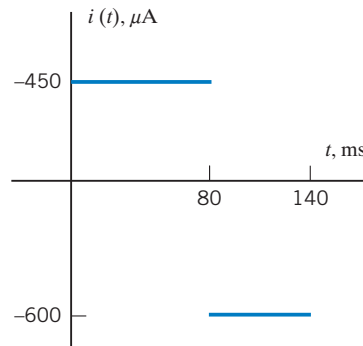

**Figure P 1.3-5**

**P 1.3-6** The current in a circuit element is plotted in Figure P 1.3-6. Determine the total charge that flows through the circuit element between  $300$  and  $1200 \mu\text{s}$ .

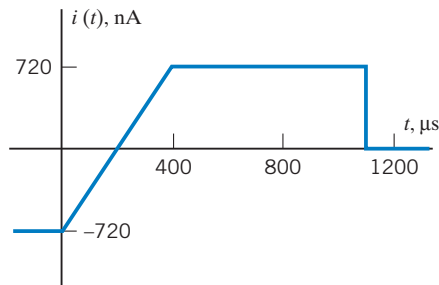

Figure P 1.3-6

## Section 1.5 Power and Energy

**P 1.5-1**  $\oplus$  Figure P 1.5-1 shows four circuit elements identified by the letters A, B, C, and D.

- Which of the devices supply 30 mW?
- Which of the devices absorb 0.03 W?
- What is the value of the power received by device B?
- What is the value of the power delivered by device B?
- What is the value of the power delivered by device C?

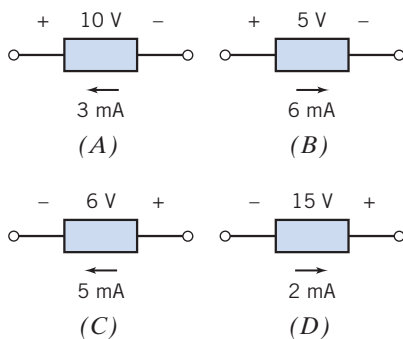
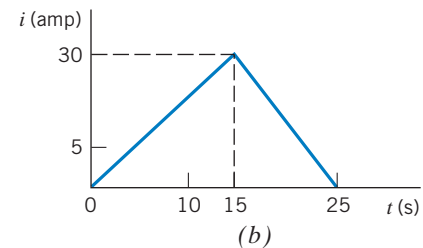
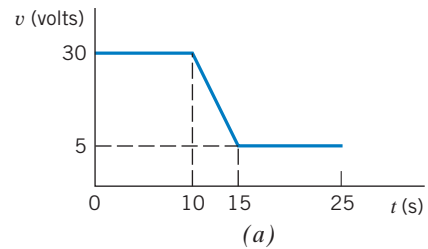

Figure P 1.5-1

**P 1.5-2**  $\oplus$  An electric range has a constant current of 10 A entering the positive voltage terminal with a voltage of 110 V. The range is operated for two hours. (a) Find the charge in coulombs that passes through the range. (b) Find the power absorbed by the range. (c) If electric energy costs 12 cents per kilowatt-hour, determine the cost of operating the range for two hours.

**P 1.5-3** A walker's cassette tape player uses four AA batteries in series to provide 6 V to the player circuit. The four alkaline battery cells store a total of 200 watt-seconds of energy. If the cassette player is drawing a constant 10 mA from the battery pack, how long will the cassette operate at normal power?

**P 1.5-4** The current through and voltage across an element vary with time as shown in Figure P 1.5-4. Sketch the power delivered to the element for  $t > 0$ . What is the total energy delivered to the element between  $t = 0$  and  $t = 25$  s? The element voltage and current adhere to the passive convention.

Figure P 1.5-4 (a) Voltage  $v(t)$  and (b) current  $i(t)$  for an element.

**P 1.5-5**  $\oplus$  An automobile battery is charged with a constant current of 2 A for five hours. The terminal voltage of the battery is  $v = 11 + 0.5t$  V for  $t > 0$ , where  $t$  is in hours. (a) Find the energy delivered to the battery during the five hours. (b) If electric energy costs 15 cents/kWh, find the cost of charging the battery for five hours.

**Answer:** (b) 1.84 cents

**P 1.5-6**  $\oplus$  Find the power,  $p(t)$ , supplied by the element shown in Figure P 1.5-6 when  $v(t) = 4 \cos 3t$  V and  $i(t) = \frac{\sin 3t}{12}$  A. Evaluate  $p(t)$  at  $t = 0.5$  s and at  $t = 1$  s. Observe that the power supplied by this element has a positive value at some times and a negative value at other times.

**Hint:**  $(\sin at)(\cos bt) = \frac{1}{2}(\sin(a+b)t + \sin(a-b)t)$

**Answer:**

$$p(t) = \frac{1}{6} \sin 6t \text{ W}, \quad p(0.5) = 0.0235 \text{ W}, \quad p(1) = -0.0466 \text{ W}$$

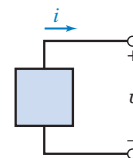

Figure P 1.5-6 An element.

**P 1.5-7**  $\oplus$  Find the power,  $p(t)$ , supplied by the element shown in Figure P 1.5-6 when  $v(t) = 8 \sin 3t$  V and  $i(t) = 2 \sin 3t$  A.

**Hint:**  $(\sin at)(\sin bt) = \frac{1}{2}(\cos(a-b)t - \cos(a+b)t)$

**Answer:**  $p(t) = 8 - 8\cos 6t$  W

**P 1.5-8**  $\oplus$  Find the power,  $p(t)$ , supplied by the element shown in Figure P 1.5-6. The element voltage is represented as  $v(t) = 4(1 - e^{-2t})\text{V}$  when  $t \geq 0$  and  $v(t) = 0$  when  $t < 0$ . The element current is represented as  $i(t) = 2e^{-2t}\text{A}$  when  $t \geq 0$  and  $i(t) = 0$  when  $t < 0$ .

**Answer:**  $p(t) = 8(1 - e^{-2t})e^{-2t}\text{W}$

**P 1.5-9**  $\oplus$  The battery of a flashlight develops 3 V, and the current through the bulb is 200 mA. What power is absorbed by the bulb? Find the energy absorbed by the bulb in a five-minute period.

**P 1.5-10** Medical researchers studying hypertension often use a technique called “2D gel electrophoresis” to analyze the protein content of a tissue sample. An image of a typical “gel” is shown in Figure P1.5-10a.

The procedure for preparing the gel uses the electric circuit illustrated in Figure 1.5-10b. The sample consists of a gel and a filter paper containing ionized proteins. A voltage source causes a large, constant voltage, 500 V, across the sample. The large, constant voltage moves the ionized proteins from the filter paper to the gel. The current in the sample is given by

$$i(t) = 2 + 30e^{-at}\text{ mA}$$

where  $t$  is the time elapsed since the beginning of the procedure and the value of the constant  $a$  is

$$a = 0.85 \frac{1}{\text{hr}}$$

Determine the energy supplied by the voltage source when the gel preparation procedure lasts 3 hours.

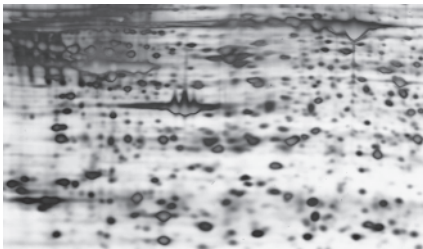

Devon Svoboda, Queen's University  
(a)

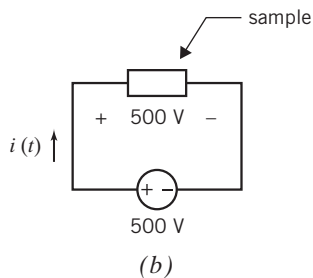

**Figure P 1.5-10** (a) An image of a gel and (b) the electric circuit used to prepare gel.

### Section 1.7 How Can We Check . . . ?

**P 1.7-1**  $\oplus$  Conservation of energy requires that the sum of the power received by all of the elements in a circuit be zero. Figure P 1.7-1 shows a circuit. All of the element voltages and

currents are specified. Are these voltage and currents correct? Justify your answer.

**Hint:** Calculate the power received by each element. Add up all of these powers. If the sum is zero, conservation of energy is satisfied and the voltages and currents are probably correct. If the sum is not zero, the element voltages and currents cannot be correct.

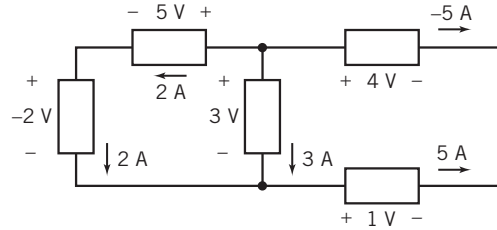

**Figure P 1.7-1**

**P 1.7-2**  $\oplus$  Conservation of energy requires that the sum of the power received by all of the elements in a circuit be zero. Figure P 1.7-2 shows a circuit. All of the element voltages and currents are specified. Are these voltage and currents correct? Justify your answer.

**Hint:** Calculate the power received by each element. Add up all of these powers. If the sum is zero, conservation of energy is satisfied and the voltages and currents are probably correct. If the sum is not zero, the element voltages and currents cannot be correct.

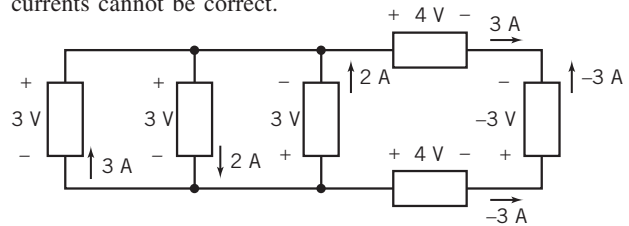

**Figure P 1.7-2**

**P 1.7-3**  $\oplus$  The element currents and voltages shown in Figure P 1.7-3 are correct with one exception: the reference direction of exactly one of the element currents is reversed. Determine which reference direction has been reversed.

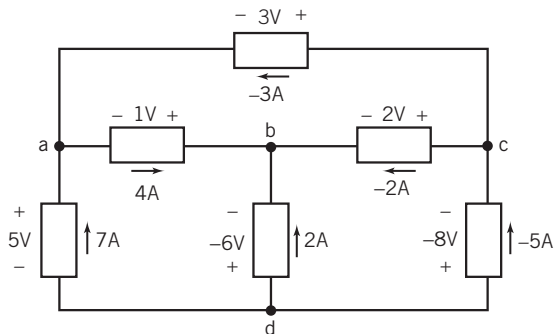

**Figure P 1.7-3**

## Design Problems

**DP 1-1** A particular circuit element is available in three grades. Grade A guarantees that the element can safely absorb  $1/2\text{ W}$  continuously. Similarly, Grade B guarantees that  $1/4\text{ W}$  can be absorbed safely, and Grade C guarantees that  $1/8\text{ W}$  can be absorbed safely. As a rule, elements that can safely absorb more power are also more expensive and bulkier.

The voltage across an element is expected to be about  $20\text{ V}$ , and the current in the element is expected to be about  $8\text{ mA}$ . Both estimates are accurate to within 25 percent. The voltage and current reference adhere to the passive convention.

Specify the grade of this element. Safety is the most important consideration, but don't specify an element that is more expensive than necessary.

**DP 1-2** The voltage across a circuit element is  $v(t) = 20(1 - e^{-8t})$  V when  $t \geq 0$  and  $v(t) = 0$  when  $t < 0$ . The current in this element is  $i(t) = 30e^{-8t}$  mA when  $t \geq 0$  and  $i(t) = 0$  when  $t < 0$ . The element current and voltage adhere to the passive convention. Specify the power that this device must be able to absorb safely.

**Hint:** Use MATLAB, or a similar program, to plot the power.