

1

Preliminaries

Chapter Outline

This chapter provides theoretical fundamentals for the considerations presented in the subsequent chapters. It is divided into four sections, containing some key concepts, facts and expressions from Statics, Kinematics, Kinetics and Strength of Materials.

Chapter Objectives

- To present preliminaries from Statics, Kinematics, Kinetics and Strength of Materials
- To focus only on the key concepts, facts and expressions of interest for the considerations presented in this book
- To provide help to readers to enable them to use this book on a stand-alone basis

1.1 From Statics

1.1.1 Mechanical Systems and Equilibrium Equations

Of interest here is the equilibrium of different systems of forces and torques lying in one plane. They are given separately in Table 1.1.1 together with the corresponding equilibrium equations and their descriptions. Note that before writing these equations, one must create a free-body diagram for the object under consideration if it is not free. The way to do this is described in Table 1.1.2.

1.1.2 Constraints and Free-Body Diagrams

When considering the equilibrium of an object or combinations of objects via equations of motion, it is essential to isolate them from all surrounding bodies. This isolation is accomplished by the free-body diagram, which shows all active forces and active torques acting on the object or combinations of objects as well as forces and torques that exist due to mechanical contacts with surrounding bodies, which represent the so-called *mechanical constraints*. There are several common types that can exist in a plane, and they are collected and described in Table 1.1.2. Note that these forces and torques are also called passive forces and passive torques.

Mechanical Vibration: Fundamentals with Solved Examples, First Edition.
Ivana Kovačić and Dragi Radomirović.
© 2018 John Wiley & Sons Ltd. Published 2018 by John Wiley & Sons Ltd.

Table 1.1.1

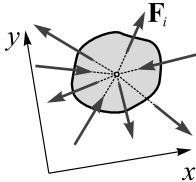
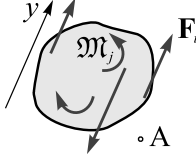
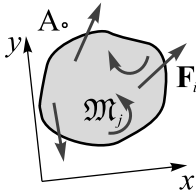
Type	Mechanical model	Equilibrium equations
Concurrent forces		<ol style="list-style-type: none"> $\sum F_x = 0$ $\sum F_y = 0$ <p>Sum of the projections of all forces on two orthogonal axes is equal to zero.</p>
Parallel forces and torques in the same plane		<ol style="list-style-type: none"> $\sum F_y = 0$ $\sum M_A = 0$ <p>Sum of the projections of forces on the axis parallel to the direction of the forces is equal to zero.</p> <p>Sum of the moments about any point A on or off the body is equal to zero.</p>
Arbitrary forces and torques in one plane		<ol style="list-style-type: none"> $\sum F_x = 0$ $\sum F_y = 0$ $\sum M_A = 0$ <p>Sum of the projections of all forces on two orthogonal axes is equal to zero.</p> <p>Sum of the moments about any point A on or off the body is equal to zero.</p> <p>The alternative equilibrium equations are:</p> <ol style="list-style-type: none"> three equilibrium equations with the zero sum of moments for any three points that are not on the same straight line; one force equilibrium equation in an arbitrary x-direction and two equilibrium equations with the zero sums of moments for any two points that must not lie on a line perpendicular to the x-direction.

1.1.3 Equilibrium Condition Via Virtual Work

Besides the approach based on the equilibrium equation, one can determine and investigate equilibria based on the principle of virtual work.

The virtual work of a force is the scalar product of the vector of the force and the virtual displacement of the point at which it acts. This can be further expressed in the rectangular/Cartesian coordinate system as follows:

$$\delta A^F = \mathbf{F} \cdot \delta \mathbf{r}_A = (F_x \mathbf{i} + F_y \mathbf{j}) \cdot (\delta x_A \mathbf{i} + \delta y_A \mathbf{j}) = F_x \delta x_A + F_y \delta y_A. \quad (1.1.1)$$

Table 1.1.2

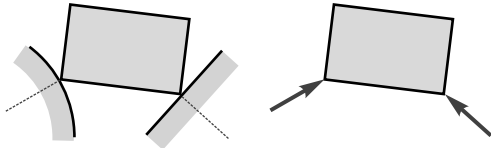
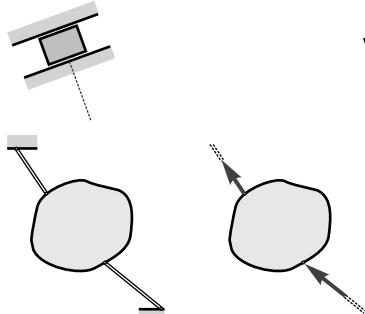
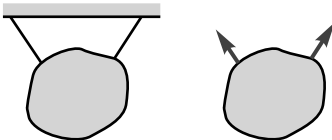
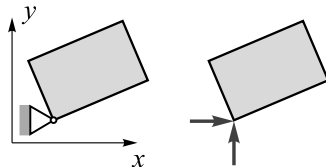
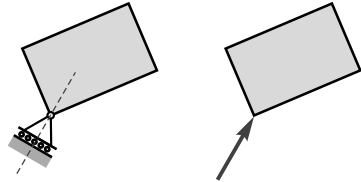
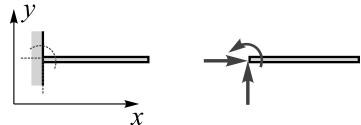
Type	Schematics	Description
Smooth surface		Contact force is compressive and is normal to the tangent at the point of contact.
Weightless straight rod		Force exerted is in the direction of the straight rod, but it can be tensile or compressive.
Rope/Cable		Force exerted is always a tension away from the body in the direction of the rope.
Pin connection		Force exerted lies in the plane normal to the pin axis; this force is usually shown in terms of two orthogonal components (for example, horizontal and vertical).
Roller/Rocker/Ball support		Compressive force normal to the supporting surface/guide.
Fixed or built-in support		Two orthogonal components of a force and a torque.

The virtual work of a torque on the virtual rotation $\delta\phi$ can be defined as

$$\delta A^{Ml} = \pm Ml\delta\phi, \tag{1.1.2}$$

where the plus sign corresponds to the case when the torque helps to increase of the angle of rotation, while the minus sign holds in the opposite case.

For the case of a system of forces and torques, the overall virtual work is the sum of the virtual work of each of them:

$$\delta A = \sum_{j=1}^u \delta A^{F_j} + \sum_{k=1}^v \delta A^{M_k}. \quad (1.1.3)$$

If the position of the mechanical system is depicted by N generalised coordinates q_i ($i = 1, \dots, N$), one can express Equation (1.1.3) in the form

$$\delta A = \sum_{i=1}^N Q_{q_i} \delta q_i, \quad (1.1.4)$$

where the coefficients Q_{q_i} represent the so-called *generalised forces* (see Section 2.4). In the equilibrium position, the generalised forces are equal to zero:

$$Q_{q_i} = 0. \quad (1.1.5)$$

Note that the number of homogeneous algebraic equations (1.1.5) is equal to the number of generalised coordinates, that is, the number of degrees of freedom. For example, if the system has one degree of freedom, there is one generalised force and one equation (1.1.5) to determine the equilibrium or any other parameter that yields it. For two-degree-of-freedom systems, two equations (1.1.5) exist, and so on.

It should also be noted that in the case of ideal constraints (see Table 1.1.2), the virtual work of the corresponding forces and torques is equal to zero. This implies that when solving the examples related to static equilibria, one does not need to introduce reactions of ideal constraints as their virtual work is zero.

1.2 From Kinematics

Kinematics deals with the geometrical aspects of motion of particles and rigid bodies, as well as with the mathematical description of their motion and certain velocities and accelerations they have over time.

1.2.1 Kinematics of Particles

A particle moving in a plane is shown in Figure 1.2.1. To study its motion, different coordinates can be used. For example, a set of two mutually orthogonal axes x and y with the origin O can be arbitrary chosen, but the axes must be fixed (Figure 1.2.1a). The unit vectors are, respectively, \mathbf{i} and \mathbf{j} . The position vector is directed from the origin to the particle and is defined by:

$$\mathbf{r} = x\mathbf{i} + y\mathbf{j}, \quad (1.2.1)$$

where x and y , in general, change over time t , that is, $x = x(t)$ and $y = y(t)$.

The particle's velocity \mathbf{v} and acceleration \mathbf{a} are defined by:

$$\mathbf{v} = \frac{d\mathbf{r}}{dt} = \dot{x}\mathbf{i} + \dot{y}\mathbf{j}, \quad (1.2.2)$$

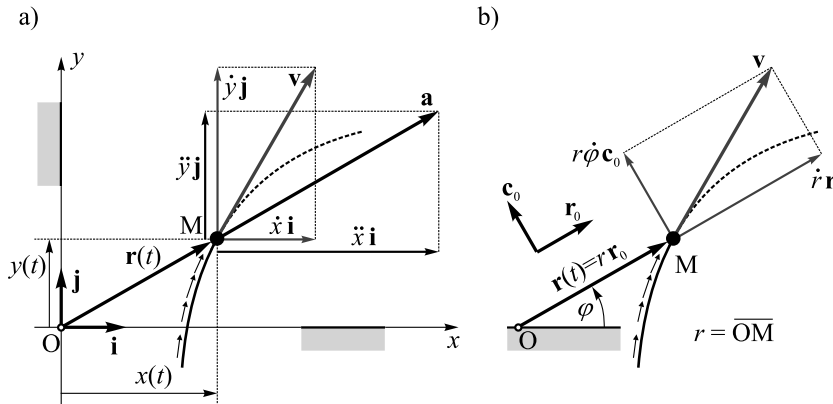

Figure 1.2.1

$$\mathbf{a} = \frac{d\mathbf{v}}{dt} = \frac{d^2\mathbf{r}}{dt^2} = \ddot{x}\mathbf{i} + \ddot{y}\mathbf{j}, \tag{1.2.3}$$

where the overdot indicates differentiation with respect to time.

Besides this, one can use polar coordinates (Figure 1.2.1b) $r = r(t)$ and $\varphi = \varphi(t)$ with the moveable unit vectors \mathbf{r}_0 and \mathbf{c}_0 . The velocity of the particle has two components:

$$\mathbf{v} = \frac{d\mathbf{r}}{dt} = \dot{r}\mathbf{r}_0 + r\dot{\varphi}\mathbf{c}_0. \tag{1.2.4}$$

1.2.2 Kinematics of Rigid Bodies

1.2.2.1 Rigid Body in Translatory Motion

During translatory motion every line in the body remains parallel to its original position at all times. One can distinguish rectilinear translation (Figure 1.2.2), when all points move along parallel straight lines, and curvilinear translation (Figure 1.2.3), when all points move along congruent curves. During translatory motion all points have the same velocity as noted in Figures 1.2.2 and 1.2.3. Thus, specifying the motion of one point enables one to describe completely the translation of the whole body.

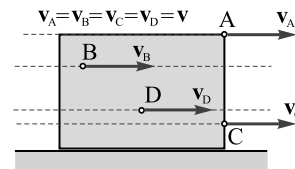

Figure 1.2.2

1.2.2.2 Rigid Body in Fixed-Axis Rotation

During rotation about a fixed axis (Figure 1.2.4) all points in a rigid body (other than those on the axis) move along concentric circular paths around the axis of rotation. Note that the axis of rotation in Figure 1.2.4 passes through the point O and is perpendicular to the plane of the figure. The position of the body is defined by the angle between the fixed line and a line attached to the body (this angle is labelled by φ in Figure 1.2.4) and the angular velocity of the body

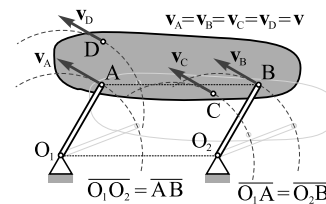

Figure 1.2.3

is $\omega = \dot{\phi}$. The velocity of each point is proportional to it, as well as to its distance with respect to the axis of rotation. Referring again to Figure 1.2.4, one can write

$$v_A = \overline{OA} \omega, \quad v_B = \overline{OB} \omega, \quad v_C = \overline{OC} \omega. \quad (1.2.5)$$

1.2.2.3 Rigid Body in General Plane Motion

General plane motion of a rigid body is a combination of translation and rotation around the axis perpendicular to the plane in which the translation takes place. Thus, the velocities of any two points of the body are mutually related by the expression (see Figure 1.2.5):

$$\mathbf{v}_B = \mathbf{v}_A + \mathbf{v}_{B/A}, \quad (1.2.6)$$

where $v_{B/A} = \overline{AB} \omega$, $\mathbf{v}_{B/A} \perp AB$.

Another way to consider general plane motion of a rigid body is to locate the point whose instantaneous velocity is equal to zero, which is the so-called *instantaneous centre of zero velocity*. This point is labelled by P in Figure 1.2.6. If the directions of two non-parallel velocities of any two points of the body are known, the instantaneous centre of zero velocity corresponds to the intersection point of the lines perpendicular to these velocities (see the lines perpendicular to \mathbf{v}_C and \mathbf{v}_D in Figure 1.2.6). Then, the angular velocity of the body is

$$\omega = \frac{v_C}{\overline{PC}} = \frac{v_D}{\overline{PD}}. \quad (1.2.7)$$

All other points have velocities proportional to it. For example (see Figure 1.2.6):

$$v_A = \overline{PA} \omega, \quad v_B = \overline{PB} \omega. \quad (1.2.8)$$

It is also of interest to note the case when two bodies roll along each other, but there is no slipping between

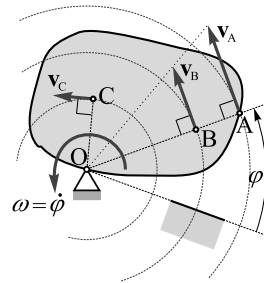

Figure 1.2.4

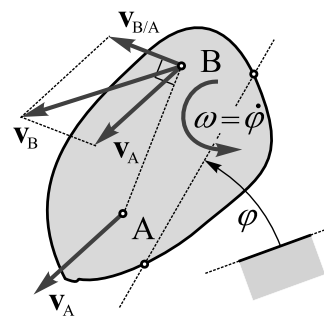

Figure 1.2.5

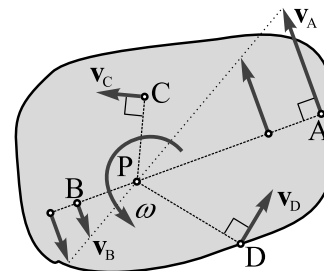

Figure 1.2.6

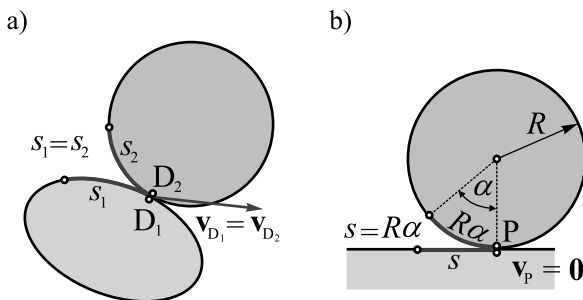

Figure 1.2.7

them, as shown in Figure 1.2.7a,b. Then, the equality of the arcs s_1 and s_2 depicted in Figure 1.2.7a must hold and the velocities of the contact points are equal ($\mathbf{v}_{D_1} = \mathbf{v}_{D_2}$). Analogously, for the disc rolling without slipping along a horizontal fixed plane shown in Figure 1.2.7b, the equality of the arc length $R\alpha$ and the distance s holds. The contact point is on the fixed plane, so its instantaneous velocity is zero and it represents the instantaneous centre of zero velocity ($\mathbf{v}_P = \mathbf{0}$).

This case is shown in more detail in Figure 1.2.8. Relating the velocity of the centre of the disc to its angular velocity, one has

$$v_C = \overline{PC} \omega = r\omega \Rightarrow \omega = \frac{v_C}{r}. \tag{1.2.9}$$

The velocities of several other points are also shown.

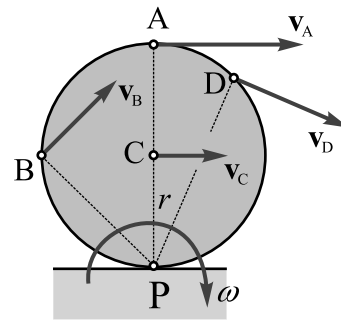

Figure 1.2.8

1.2.3 Kinematics of Particles in Compound Motion

Let us consider the motion of a point M (Figure 1.2.9) relative to a rigid body that moves relatively to a fixed coordinate system depicted by the axes x and y . The motion (trajectory, velocity, acceleration) of the point M with respect to the fixed coordinate system x - y is called *absolute*. The motion of the point M with respect the body and the coordinate system ξ - η attached to the body is called *relative*. The motion of the body with respect to the fixed coordinate systems is called *transportation*.

The theorem on composition of velocities for a compound (composition/resultant) motion states that the absolute velocity of the point is equal to the vector sum of the relative and transportation velocities of the point:

$$\mathbf{v}_M = \mathbf{v}_{rel} + \mathbf{v}_{tr}. \tag{1.2.10}$$

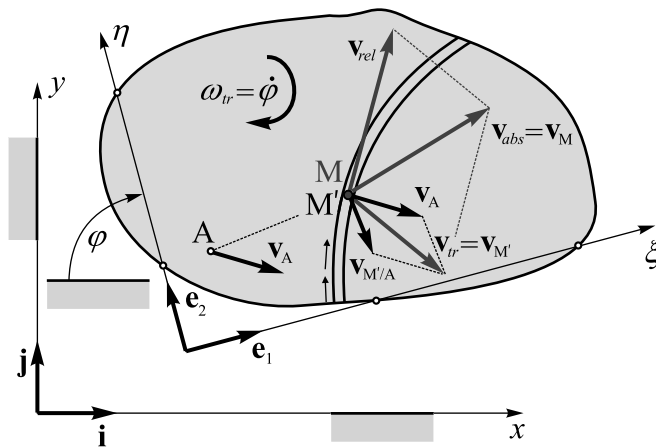

Figure 1.2.9

Note that if the body is in general plane motion, the transportation velocity is given by

$$\mathbf{v}_{tr} = \mathbf{v}_{M'} = \mathbf{v}_A + \mathbf{v}_{M'/A}, \quad (1.2.11)$$

where the point M' belongs to the body and it is located right below the point M .

1.3 From Kinetics

Kinetics deals with massive objects in motion – particles and rigid bodies – where the former can be subjected to forces and the latter to forces and torques. This subsection contains the basic relationships from Newton's dynamics needed to form their equations of motion. They are all based on free-body diagrams. This implies that the object under consideration must be isolated, and the appropriate forces and torques that exist due to mechanical contacts with surrounding bodies should be introduced as described in Table 1.1.2.

1.3.1 Kinetics of Particles

Newton's second law gives the vector relationship between the force \mathbf{F} and the acceleration \mathbf{a} of the particle of mass m :

$$m\mathbf{a} = \mathbf{F}. \quad (1.3.1)$$

When the particle is subjected to the system of concurrent forces \mathbf{F}_i , this equation becomes

$$m\mathbf{a} = \sum \mathbf{F}_i. \quad (1.3.2)$$

This vector equation can be expressed in scalar form by using different coordinates (rectangular/Cartesian coordinates, polar coordinates, etc.). For example, in the rectangular coordinates (Figure 1.3.1), Equation (1.3.2) is transformed into two second-order ordinary differential equations

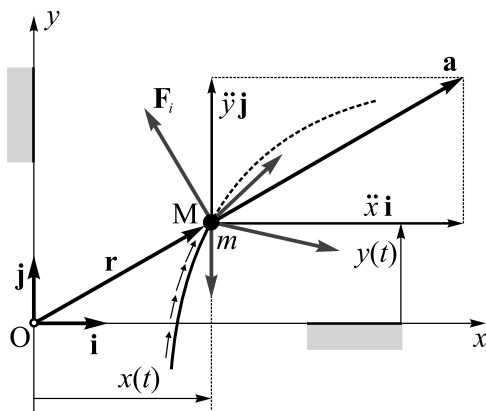

Figure 1.3.1

A general expression for the kinetic energy of the rigid body in translatory motion is:

$$T = \frac{1}{2} m \mathbf{v}_C \cdot \mathbf{v}_C = \frac{1}{2} m v_C^2. \quad (1.3.9)$$

Due to the characteristics of translatory motion (see Section 1.2.2.1), one can use the velocity of any other point of the rigid body instead of v_C .

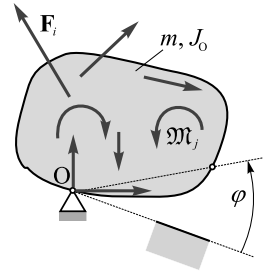

Figure 1.3.3

1.3.2.2 Kinetics of Rigid Bodies in Fixed-Axis Rotation

For a rigid body in fixed-axis rotation, the differential equation of motion is related to a moment equation about the rotation axis through O (Figure 1.3.3) and has the form

$$J_O \ddot{\varphi} = \sum M_O, \quad (1.3.10)$$

where φ is the angle of rotation, and J_O is the mass moment of inertia for the rotation axis through O. The positive sign of the moment corresponds to an increase in the angle of rotation.

A general expression for the kinetic energy of a rigid body in fixed-axis rotation is:

$$T = \frac{1}{2} J_O \omega^2. \quad (1.3.11)$$

The way to calculate the mass moment of inertia for different shapes of uniform bodies is presented below.

On the mass moment of inertia

According to the parallel-axis theorem, the relationship between the mass moment of inertia about the axis z through the centre of mass C and a parallel axis z_1 through another point O (Figure 1.3.4) is given by

$$J_{z_1} = J_z + m b^2. \quad (1.3.12)$$

This can be written in a simplified form by indicating the points on the body:

$$J_O = J_C + m \overline{OC}^2; \quad (1.3.13)$$

this is the form that will mainly be used through this book. Mass moments of inertia of some common shapes are given in Table 1.3.1. Note that mass moment of inertia can be calculated based on the so-called radius of gyration i about a given axis. It represents the perpendicular distance from the axis to a particle of mass m that gives an equivalent mass moment of inertia to the original object of the same mass. Thus, for example, $J_C \equiv J_z = m i_C^2 \equiv m i_z^2$ and $J_O \equiv J_{z_1} = m i_O^2 \equiv m i_{z_1}^2$.

1.3.2.3 Kinetics of Rigid Bodies in General Plane Motion

The general equations of motion for a rigid body of mass m in general plane motion (Figure 1.3.5) involve the vector equation of motion of the centre of mass C and the equation of rotation around the axis through the centre of mass.

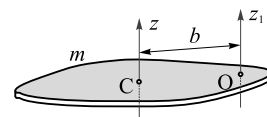
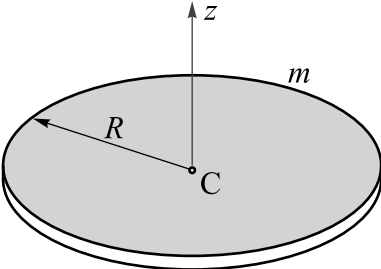
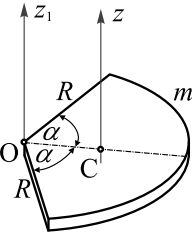
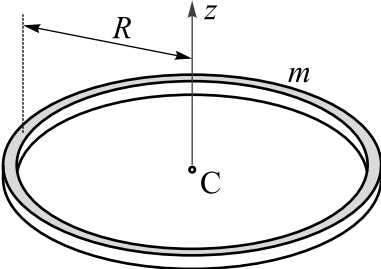
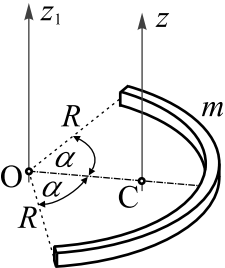
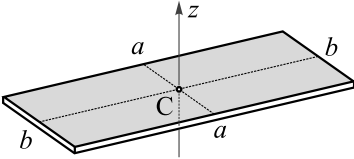

Figure 1.3.4

Table 1.3.1

Shape	Presentation	Mass moment of inertia
Disc		$J_C \equiv J_z = \frac{1}{2}mR^2$
Circular sector		$J_O \equiv J_{z_1} = \frac{1}{2}mR^2$ $\overline{OC} = \frac{2}{3}R \frac{\sin \alpha}{\alpha}$
Ring		$J_C \equiv J_z = mR^2$
Circular arch		$J_O \equiv J_{z_1} = mR^2$ $\overline{OC} = R \frac{\sin \alpha}{\alpha}$
Rectangle		$J_C \equiv J_z = \frac{1}{12}m(a^2 + b^2)$

(Continued)

Table 1.3.1 (Continued)

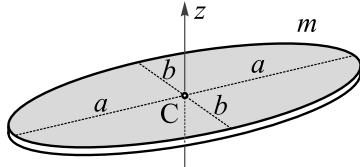
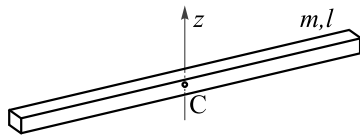
Shape	Presentation	Mass moment of inertia
Ellipse		$J_C \equiv J_z = \frac{1}{4}m(a^2 + b^2)$
Slender rod		$J_C \equiv J_z = \frac{1}{12}ml^2$

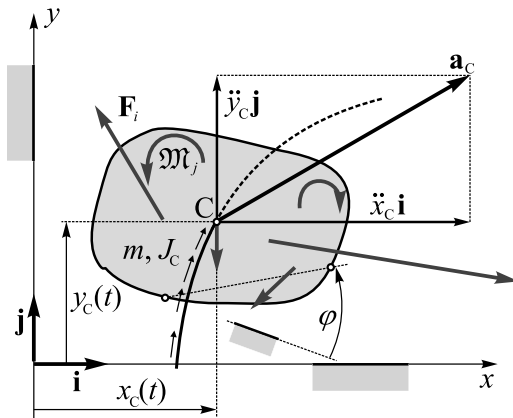

Figure 1.3.5

Using the rectangular coordinates for the former (see Figure 1.3.5), one can write them in the form of three second-order ordinary differential equations

$$m\ddot{x}_C = \sum F_x, \tag{1.3.14}$$

$$m\ddot{y}_C = \sum F_y. \tag{1.3.15}$$

$$J_C\ddot{\varphi} = \sum M_C. \tag{1.3.16}$$

Note that the mass moment of inertia corresponds to the axis through the centre of mass as well as that the moment on the right-hand side of Equation (1.3.16) should be calculated for the centre of mass. The positive sign of the moments corresponds to an increase in the angle of rotation.

A general expression for the kinetic energy of the rigid body in general plane motion is given by the sum of two terms – one corresponding to the kinetic energy of translatory motion and the other to rotation around the axis through the centre:

$$T = \frac{1}{2}mv_C^2 + \frac{1}{2}J_C\omega^2. \quad (1.3.17)$$

Alternatively, given the kinematics of this motion (see Section 1.2.2.3), the kinetic energy can also be determined based on:

$$T = \frac{1}{2}J_P\omega^2, \quad (1.3.18)$$

where P stands for the instantaneous centre of zero velocity.

1.4 From Strength of Materials

Chapter 8 of this book contains the investigations of oscillations of certain continuous systems: longitudinal (axial) vibration of bars, torsional vibration of shafts and transversal vibration of beams. These investigations require the use of certain facts and expressions from Strength of Materials and they are presented herein for three types of loading.

1.4.1 Axial Loading

A uniform elastic bar of cross-sectional area A is considered (Figure 1.4.1a). It is made of Hooke's material whose Young's modulus is E . Let us focus now on the infinitesimally small element of the bar (Figure 1.4.1b) placed at the location defined by x . Its length is dx , and the corresponding free-body diagram is presented in Figure 1.4.1c. If the bar is axially loaded, the internal force S is generated, and the displacement caused is labelled by $u = u(x)$.

To determine the expression for this internal force, Hooke's law can be used, relating the force to the axial stress σ and the axial strain $du(x)/dx$ as follows:

$$S = \sigma A = E \frac{du}{dx} A. \quad (1.4.1)$$

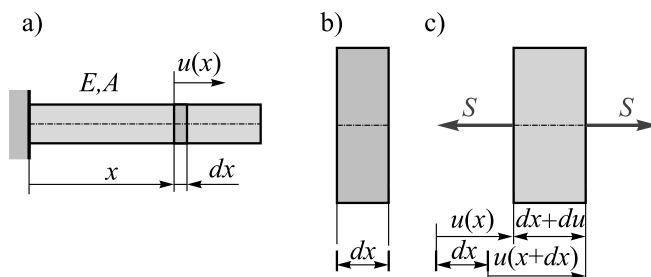

Figure 1.4.1

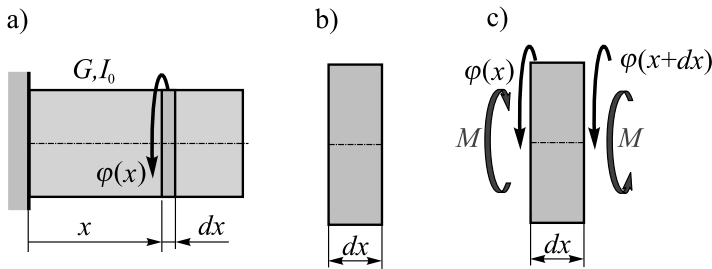

Figure 1.4.2

1.4.2 Torsion

The object of interest is a uniform elastic shaft of polar moment of inertia I_0 (Figure 1.4.2a). The shaft is made of a material whose shear modulus is G . The infinitesimally small element of length dx , placed at location x is considered (Figure 1.4.2b), and the corresponding free-body diagram is presented in Figure 1.4.2c.

The internal torques (twisting torques) acting on this element are labelled by M , and the angle of rotation (twist) is labelled by $\varphi = \varphi(x)$. They are mutually related by the expression:

$$M = GI_0 \frac{d\varphi}{dx}. \tag{1.4.2}$$

1.4.3 Bending

Bending of beams is considered now (Figure 1.4.3a). The uniform beam is assumed to be made of Hooke’s material whose Young’s modulus is E . The moment of inertia of the beam cross-section about the neutral axis is labelled by I . The displacement u of each section depends on its location x , that is, $u = u(x)$. An infinitesimally small element of length dx is shown in Figure 1.4.3b. Its free-body diagram is presented in Figure 1.4.3c. This element is subjected to internal forces and bending moments M . The internal forces include shear forces F_s and axial forces, which are not shown for brevity.

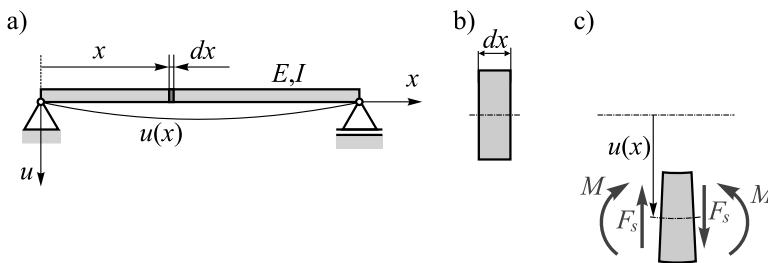

Figure 1.4.3

The relationship between the shear force F_s and the bending moment M is given by:

$$F_s = \frac{dM}{dx}, \quad (1.4.3)$$

while the expression relating the bending moment and the deflection has the form:

$$M = -EI \frac{d^2u}{dx^2}. \quad (1.4.4)$$

