

PART I

EUCLIDEAN GEOMETRY

COPYRIGHTED MATERIAL

CHAPTER 1

CONGRUENCY

1.1 Introduction

Assumed Knowledge

This text assumes a bit of knowledge on the part of the reader. For example, it assumes that you know that the sum of the angles of a triangle in the plane is 180° ($x + y + z = 180^\circ$ in the figure below), and that in a right triangle with hypotenuse c and sides a and b , the Pythagorean relation holds: $c^2 = a^2 + b^2$.

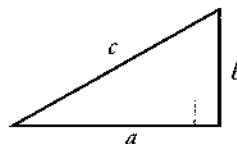
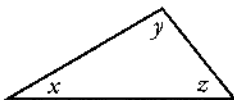

We use the word *line* to mean *straight line*, and we assume that you know that two lines either do not intersect, intersect at exactly one point, or completely coincide. Two lines that do not intersect are said to be *parallel*.

We also assume certain knowledge about parallel lines, namely, that you have seen some form of the *parallel axiom*:

Given a line l and a point P in the plane, there is exactly one line through P parallel to l .

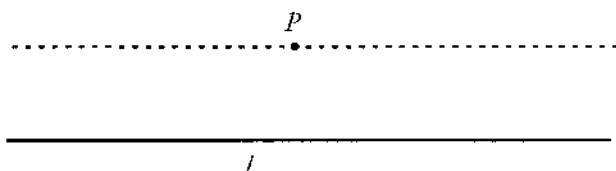

The preceding version of the parallel axiom is often called *Playfair's Axiom*. You may even know something equivalent to it that is close to the original version of the *parallel postulate*:

Given two lines l and m , and a third line t cutting both l and m and forming angles ϕ and θ on the same side of t , if $\phi + \theta < 180^\circ$, then l and m meet at a point on the same side of t as the angles.

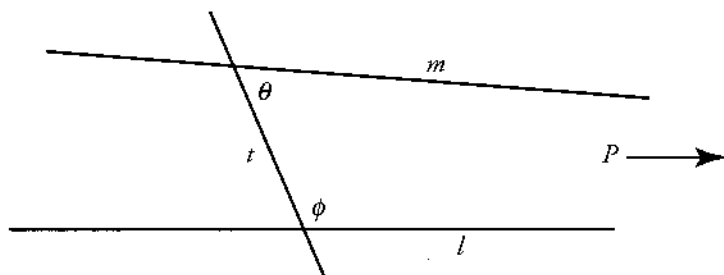

The subject of this part of the text is Euclidean geometry, and the above-mentioned parallel postulate characterizes Euclidean geometry. Although the postulate may seem to be obvious, there are perfectly good geometries in which it does not hold.

We also assume that you know certain facts about areas. A **parallelogram** is a quadrilateral (figure with four sides) such that the opposite sides are parallel.

The area of a parallelogram with base b and height h is $b \cdot h$, and the area of a triangle with base b and height h is $b \cdot h/2$.

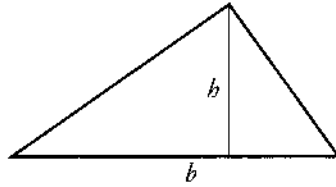
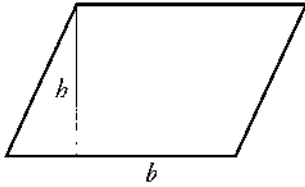

Notation and Terminology

Throughout this text, we use uppercase Latin letters to denote points and lowercase Latin letters to denote lines and rays. Given two points A and B , there is one and only one line through A and B . A **ray** is a half-line, and the notation \overrightarrow{AB} denotes the ray starting at A and passing through B . It consists of the points A and B , all points between A and B , and all points X on the line such that B is between A and X .

Given rays \overrightarrow{AB} and \overrightarrow{AC} , we denote by $\angle BAC$ the angle formed by the two rays (the shaded region in the following figure). When no confusion can arise, we sometimes use $\angle A$ instead of $\angle BAC$. We also use lowercase letters, either Greek or Latin, to denote angles.

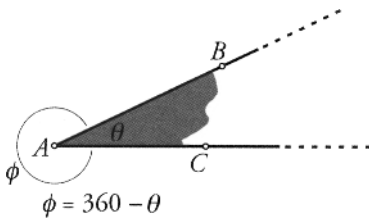

When two rays form an angle other than 180° , there are actually two angles to talk about: the smaller angle (sometimes called the **interior angle**) and the larger angle (called the **reflex angle**). When we refer to $\angle BAC$, we always mean the nonreflex angle.

Note. The angles that we are talking about here are *undirected angles*; that is, they do not have negative values, and so can range in magnitude from 0° to 360° . Some people prefer to use $m(\angle A)$ for the measure of the angle A ; however, we will use the same notation for both the angle and the measure of the angle.

When we refer to a quadrilateral as $ABCD$ we mean one whose edges are AB , BC , CD , and DA . Thus, the quadrilateral $ABCD$ and the quadrilateral $ABDC$ are quite different.

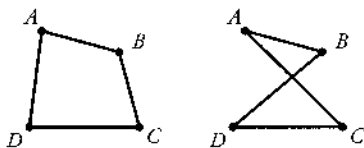

There are three classifications of quadrilaterals: convex, simple, and nonsimple, as shown in the following diagram.

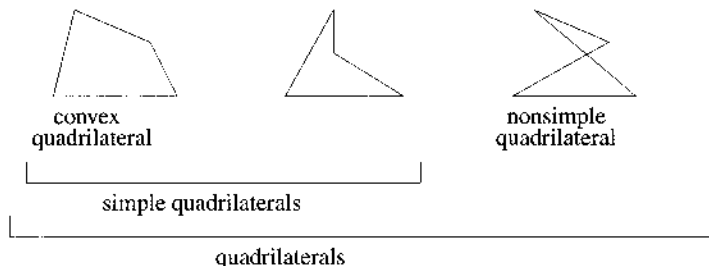

1.2 Congruent Figures

Two figures that have exactly the same shape and exactly the same size are said to be *congruent*. More explicitly:

1. Two angles are *congruent* if they have the same measure.
2. Two line segments are *congruent* if they are the same length.
3. Two circles are *congruent* if they have the same radius.
4. Two triangles are *congruent* if corresponding sides and angles are the same size.
5. All rays are *congruent*.
6. All lines are *congruent*.

Theorem 1.2.1. *Vertically opposite angles are congruent.*

Proof. We want to show that $a = b$. We have

$$a + c = 180 \text{ and } b + c = 180,$$

and it follows from this that $a = b$.

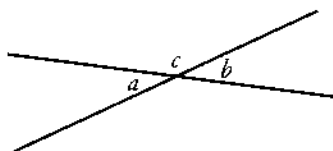

□

Notation. The symbol \equiv denotes congruence. We use the notation $\triangle ABC$ to denote a triangle with vertices A , B , and C , and we use $\mathcal{C}(P, r)$ to denote a circle with center P and radius r .

Thus, $\mathcal{C}(P, r) \equiv \mathcal{C}(Q, s)$ if and only if $r = s$.

We will be mostly concerned with the notion of congruent triangles, and we mention that in the definition, $\triangle ABC \equiv \triangle DEF$ if and only if the following six conditions hold:

$$\begin{aligned}\angle A &\equiv \angle D \\ \angle B &\equiv \angle E \\ \angle C &\equiv \angle F \\ AB &\equiv DE \\ BC &\equiv EF \\ AC &\equiv DF.\end{aligned}$$

Note that the two statements $\triangle ABC \equiv \triangle DEF$ and $\triangle ABC \equiv \triangle EFD$ are not the same!

The Basic Congruency Conditions

According to the definition of congruency, two triangles are congruent if and only if six different parts of one are congruent to the six corresponding parts of the other. Do we really need to check all six items? The answer is no.

If you give three straight sticks to one person and three identical sticks to another and ask both to construct a triangle with the sticks as the sides, you would expect the two triangles to be exactly the same. In other words, you would expect that it is possible to verify congruency by checking that the three corresponding sides are congruent. Indeed this is the case, and, in fact, there are several ways to verify congruency without checking all six conditions.

The three congruency conditions that are used most often are the Side-Angle-Side (SAS) condition, the Side-Side-Side (SSS) condition, and the Angle-Side-Angle (ASA) condition.

Axiom 1.2.2. (SAS Congruency)

Two triangles are congruent if two sides and the included angle of one are congruent to two sides and the included angle of the other.

Theorem 1.2.3. (SSS Congruency)

Two triangles are congruent if the three sides of one are congruent to the corresponding three sides of the other.

Theorem 1.2.4. (ASA Congruency)

Two triangles are congruent if two angles and the included side of one are congruent to two angles and the included side of the other.

You will note that the SAS condition is an axiom, and the other two are stated as theorems. We will not prove the theorems but will freely use all three conditions.

Any one of the three conditions could be used as an axiom with the other two then derived as theorems. In case you are wondering why the SAS condition is preferred as the basic axiom rather than the SSS condition, it is because *it is always possible to construct a triangle given two sides and the included angle*, whereas it is not always possible to construct a triangle given three sides (consider sides of length 3, 1, and 1).

Axiom 1.2.5. (The Triangle Inequality)

The sum of the lengths of two sides of a triangle is always greater than the length of the remaining side.

The congruency conditions are useful because they allow us to conclude that certain parts of two triangles are congruent by determining that certain other parts are congruent.

Here is how congruency may be used to prove two well-known theorems about isosceles triangles. (An *isosceles* triangle is one that has two equal sides.)

Theorem 1.2.6. (The Isosceles Triangle Theorem)

In an isosceles triangle, the angles opposite the equal sides are equal.

Proof. Let us suppose that the triangle is ABC with $AB = AC$.

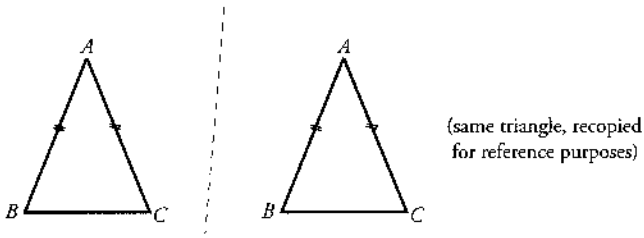

In $\triangle ABC$ and $\triangle ACB$ we have

$$\begin{aligned} AB &= AC, \\ \angle BAC &= \angle CAB, \\ AC &= AB, \end{aligned}$$

so $\triangle ABC \equiv \triangle ACB$ by **SAS**.

Since the triangles are congruent, it follows that all corresponding parts are congruent, so $\angle B$ of $\triangle ABC$ must be congruent to $\angle C$ of $\triangle ACB$.

□

Theorem 1.2.7. (*Converse of the Isosceles Triangle Theorem*)

If in $\triangle ABC$ we have $\angle B = \angle C$, then $AB = AC$.

Proof. In $\triangle ABC$ and $\triangle ACB$ we have

$$\begin{aligned} \angle ABC &= \angle ACB, \\ BC &= CB, \\ \angle ACB &= \angle ABC, \end{aligned}$$

so $\triangle ABC \equiv \triangle ACB$ by **ASA**.

Since $\triangle ABC \equiv \triangle ACB$ it follows that $AB = AC$.

□

Perhaps now is a good time to explain what the converse of a statement is. Many statements in mathematics have the form

If \mathcal{P} , then \mathcal{Q} ,

where \mathcal{P} and \mathcal{Q} are assertions of some sort.

For example:

If $ABCD$ is a square, then angles A , B , C , and D are all right angles.

Here, P is the assertion " $ABCD$ is a square," and Q is the assertion "angles A , B , C , and D are all right angles."

The *converse* of the statement "If P , then Q " is the statement

If Q , then P .

Thus, the converse of the statement "If $ABCD$ is a square, then angles A , B , C , and D are all right angles" is the statement

If angles A , B , C , and D are all right angles, then $ABCD$ is a square.

A common error in mathematics is to confuse a statement with its converse. Given a statement and its converse, if one of them is true, it does not automatically follow that the other is also true.

Exercise 1.2.8. For each of the following statements, state the converse and determine whether it is true or false.

1. Given triangle ABC , if $\angle ABC$ is a right angle, then $AB^2 + BC^2 = AC^2$.
2. If $ABCD$ is a parallelogram, then $AB = CD$ and $AD = BC$.
3. If $ABCD$ is a convex quadrilateral, then $ABCD$ is a rectangle.
4. Given quadrilateral $ABCD$, if $AC \neq BD$, then $ABCD$ is not a rectangle.

Solutions to the exercises are given at the end of the chapter.

The Isosceles Triangle Theorem and its converse raise questions about how sides are related to unequal angles, and there are useful theorems for this case.

Theorem 1.2.9. (*The Angle-Side Inequality*)

In $\triangle ABC$, if $\angle ABC > \angle ACB$, then $AC > AB$.

Proof. Draw a ray BX so that $\angle CBX \cong \angle BCA$ with X to the same side of BC as A , as in the figure on the following page.

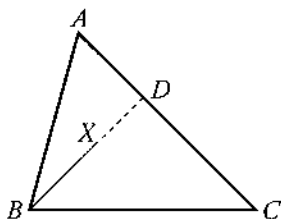

Since $\angle ABC > \angle CBX$, the point X is interior to $\angle ABC$ and so BX will cut side AC at a point D . Then we have

$$DB = DC$$

by the converse to the Isosceles Triangle Theorem.

By the Triangle Inequality, we have

$$AB < AD + DB,$$

and combining these gives us

$$AB < AD + DC = AC,$$

which is what we wanted to prove.

□

The converse of the Angle-Side Inequality is also true. Note that the proof of the converse uses the statement of the original theorem. This is something that frequently occurs when proving that the converse is true.

Theorem 1.2.10. *In $\triangle ABC$, if $AC > AB$, then $\angle ABC > \angle ACB$.*

Proof. There are three possible cases to consider:

- (1) $\angle ABC = \angle ACB$.
- (2) $\angle ABC < \angle ACB$.
- (3) $\angle ABC > \angle ACB$.

If case (1) arises, then $AC = AB$ by the converse to the Isosceles Triangle Theorem, so case (1) cannot in fact arise. If case (2) arises, then $AC < AB$ by the Angle-Side Inequality, so (2) cannot arise. The only possibility is therefore case (3).

□

The preceding examples, as well as showing how congruency is used, are facts that are themselves very useful. They can be summarized very succinctly: in a triangle,

*Equal angles are opposite equal sides.
The larger angle is opposite the larger side.*

1.3 Parallel Lines

Two lines in the plane are *parallel* if

- (a) they do not intersect or
- (b) they are the same line.

Note that (b) means that a line is parallel to itself.

Notation. We use $l \parallel m$ to denote that the lines l and m are parallel and sometimes use $l \nparallel m$ to denote that they are not parallel. If l and m are not parallel, they meet at precisely one point in the plane.

When a transversal crosses two other lines, various pairs of angles are endowed with special names:

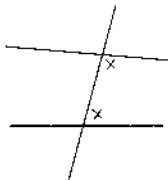

adjacent angles

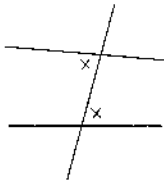

opposite or alternate
angles

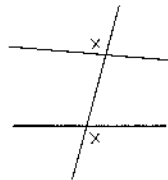

opposite or alternate
exterior angles

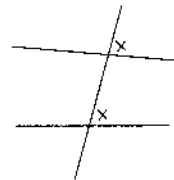

corresponding angles

The proofs of the next two theorems are omitted; however, we mention that the proof of Theorem 1.3.2 requires the parallel postulate, but the proof of Theorem 1.3.1 does not.

Theorem 1.3.1. *If a transversal cuts two lines and any one of the following four conditions holds, then the lines are parallel:*

- (1) *adjacent angles total 180° ,*
- (2) *alternate angles are equal,*
- (3) *alternate exterior angles are equal,*
- (4) *corresponding angles are equal.*

Theorem 1.3.2. *If a transversal cuts two parallel lines, then all four statements of Theorem 1.3.1 hold.*

Remark. Theorem 1.3.1 can be proved using the External Angle Inequality, which is described below. The proof of the inequality itself ultimately depends on Theorem 1.3.1, but this would mean that we are using circular reasoning, which is not permitted. However, there is a proof of the External Angle Inequality which does not in any way depend upon Theorem 1.3.1, and so it is possible to avoid circular reasoning.

1.3.1 Angles in a Triangle

The parallel postulate is what distinguishes Euclidean geometry from other geometries, and as we see now, it is also what guarantees that the sum of the angles in a triangle is 180° .

Theorem 1.3.3. *The sum of the angles of a triangle is 180° .*

Proof. Given triangle ABC , draw the line XY through A parallel to BC , as shown. Consider AB as a transversal for the parallel lines XY and BC , then $x = u$ and similarly $y = v$. Consequently,

$$x + y + w = u + v + w = 180,$$

which is what we wanted to prove.

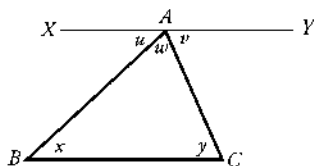

□

Given triangle ABC , extend the side BC beyond C to X . The angle ACX is called an **exterior angle** of $\triangle ABC$.

Theorem 1.3.4. (*The Exterior Angle Theorem*)

An exterior angle of a triangle is equal to the sum of the opposite interior angles.

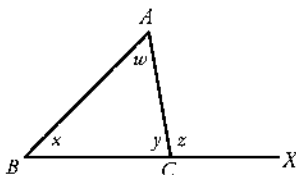

Proof. In the diagram above, we have $y + z = 180 = y + x + w$, so $z = x + w$.

□

The Exterior Angle Theorem has a useful corollary:

Corollary 1.3.5. (*The Exterior Angle Inequality*)

An exterior angle of a triangle is greater than either of the opposite interior angles.

Note. The proof of the Exterior Angle Inequality given above ultimately depends on the fact that the sum of the angles of a triangle is 180° , which turns out to be equivalent to the parallel postulate. It is possible to prove the Exterior Angle Inequality without using any facts that follow from the parallel postulate, but we will omit that proof here.

1.3.2 Thales' Theorem

One of the most useful theorems about circles is credited to Thales, who is reported to have sacrificed two oxen after discovering the proof. (In truth, versions of the theorem were known to the Babylonians some one thousand years earlier.)

Theorem 1.3.6. (*Thales' Theorem*)

An angle inscribed in a circle is half the angle measure of the intercepted arc.

In the diagram, α is the measure of the inscribed angle, the arc CD is the intercepted arc, and β is the angle measure of the intercepted arc.

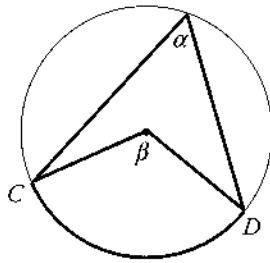

The following diagrams illustrate Thales' Theorem.

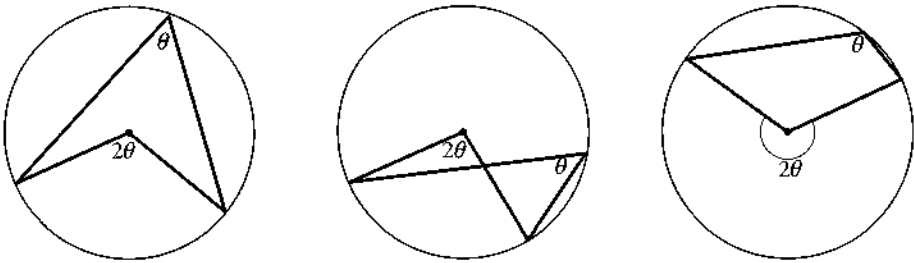

Proof. As the figures above indicate, there are several separate cases to consider. We will prove the first case and leave the others as exercises.

Referring to the diagram below, we have

$$\alpha = \nu + \omega \quad \text{and} \quad \beta = \mu + \eta.$$

But $\nu = \omega$ and $\mu = \eta$ (isosceles triangles). Consequently,

$$\angle BOC = \alpha + \beta = 2\omega + 2\eta = 2\angle BAC,$$

and the theorem follows.

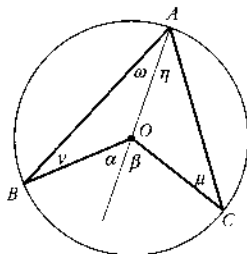

□

Thales' Theorem has several useful corollaries.

Corollary 1.3.7. *In a given circle:*

- (1) *All inscribed angles that intercept the same arc are equal in size.*
- (2) *All inscribed angles that intercept congruent arcs are equal in size.*
- (3) *The angle in a semicircle is a right angle.*

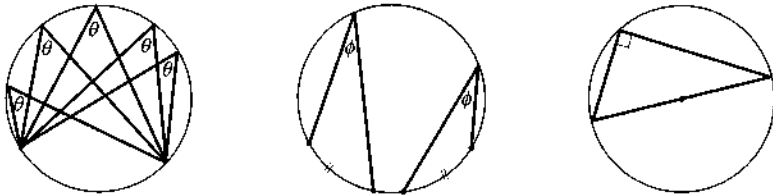

The converse of Thales' Theorem is also very useful.

Theorem 1.3.8. *(Converse of Thales' Theorem)*

Let \mathcal{H} be a halfplane determined by a line PQ . The set of points in \mathcal{H} that form a constant angle β with P and Q is an arc of a circle passing through P and Q .

Furthermore, every point of \mathcal{H} inside the circle makes a larger angle with P and Q and every point of \mathcal{H} outside the circle makes a smaller angle with P and Q .

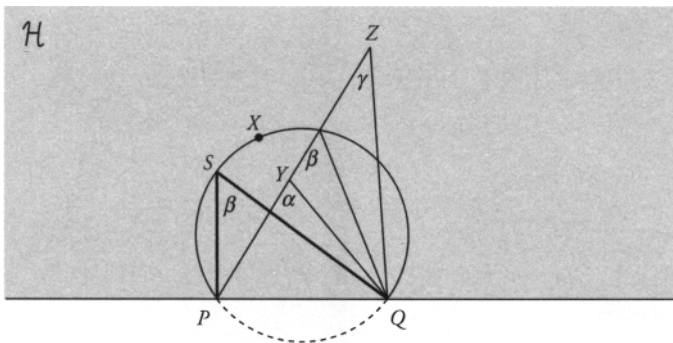

Proof. Let S be a point such that $\angle PSQ = \beta$ and let \mathcal{C} be the circumcircle of $\triangle SPQ$. In the halfplane \mathcal{H} , all points X on \mathcal{C} intercept the same arc of \mathcal{C} , so by Thales' Theorem, all angles PXQ have measure β .

From the Exterior Angle Inequality, in the figure on the previous page we have $\alpha > \beta > \gamma$. As a consequence, every point Z of \mathcal{H} outside \mathcal{C} must have $\angle PZQ < \beta$, and every point Y of \mathcal{H} inside \mathcal{C} must have $\angle PYQ > \beta$, and this completes the proof.

□

Exercise 1.3.9. Calculate the size of θ in the following figure.

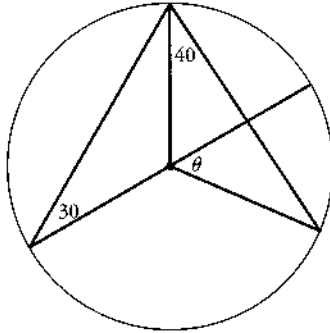

1.3.3 Quadrilaterals

The following theorem uses the fact that a simple quadrilateral always has at least one diagonal that is interior to the quadrilateral.

Theorem 1.3.10. *The sum of the interior angles of a simple quadrilateral is 360° .*

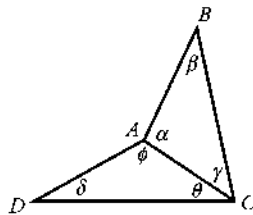
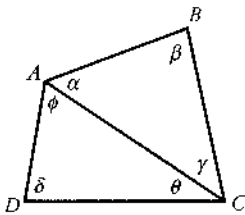

Proof. Let the quadrilateral have vertices $A, B, C,$ and $D,$ with AC being an internal diagonal. Referring to the diagram, we have

$$\begin{aligned} \angle A + \angle B + \angle C + \angle D &= (\phi + \alpha) + \beta + (\gamma + \theta) + \delta \\ &= (\alpha + \beta + \gamma) + (\theta + \delta + \phi) \\ &= 180^\circ + 180^\circ \\ &= 360^\circ. \end{aligned}$$

□

Note. This theorem is false if the quadrilateral is not simple, in which case the sum of the interior angles is less than 360° .

Cyclic Quadrilaterals

A quadrilateral that is inscribed in a circle is called a *cyclic quadrilateral* or, equivalently, a *concyclic quadrilateral*. The circle is called the *circumcircle* of the quadrilateral.

Theorem 1.3.11. *Let $ABCD$ be a simple cyclic quadrilateral. Then:*

- (1) *The opposite angles sum to 180° .*
- (2) *Each exterior angle is congruent to the opposite interior angle.*

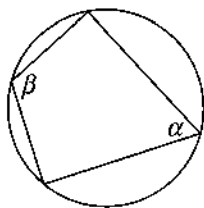

$$\alpha + \beta = 180$$

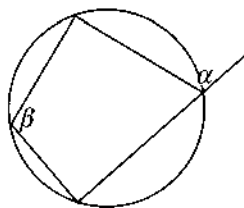

$$\alpha = \beta$$

Theorem 1.3.12. *Let $ABCD$ be a simple quadrilateral. If the opposite angles sum to 180° , then $ABCD$ is a cyclic quadrilateral.*

We leave the proofs of Theorem 1.3.11 and Theorem 1.3.12 as exercises and give a similar result for nonsimple quadrilaterals.

Example 1.3.13. *(Cyclic Nonsimple Quadrilaterals)*

A nonsimple quadrilateral can be inscribed in a circle if and only if opposite angles are equal. For example, in the figure on the following page, the nonsimple quadrilateral $ABCD$ can be inscribed in a circle if and only if $\angle A = \angle C$ and $\angle B = \angle D$.

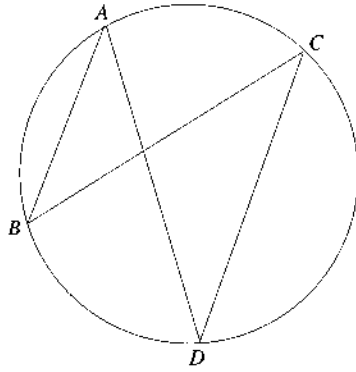

Solution. Suppose first that the quadrilateral $ABCD$ is cyclic. Then $\angle A = \angle C$ since they are both subtended by the chord BD , while $\angle B = \angle D$ since they are both subtended by the chord AC .

Conversely, suppose that $\angle A = \angle C$ and $\angle B = \angle D$, and let the circle below be the circumcircle of $\triangle ABC$.

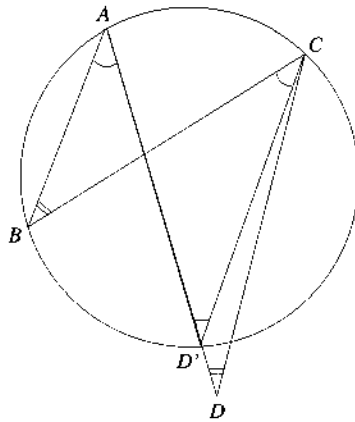

If the quadrilateral $ABCD$ is not cyclic, then the point D does not lie on this circumcircle. Assume that it lies outside the circle and let D' be the point where the line segment AD hits the circle. Since $ABCD'$ is a cyclic quadrilateral, then from the first part of the proof, $\angle B = \angle D'$ and therefore $\angle D = \angle D'$, which contradicts the External Angle Inequality in $\triangle CD'D$. Thus, if $\angle A = \angle C$ and $\angle B = \angle D$, then quadrilateral $ABCD$ is cyclic.

□

Exercise 1.3.14. Show that a quadrilateral has an inscribed circle (that is, a circle tangent to each of its sides) if and only if the sums of the lengths of the two pairs of opposite sides are equal. For example, the quadrilateral $ABCD$ has an inscribed circle if and only if $AB + CD = AD + BC$.

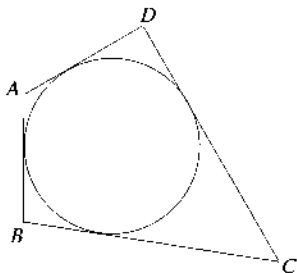

The following example is a result named after Robert Simson (1687–1768), whose *Elements of Euclid* was a standard textbook published in 24 editions from 1756 until 1834 and upon which many modern English versions of Euclid are based. However, in their book *Geometry Revisited*, Coxeter and Greitzer report that the result attributed to Simson was actually discovered later, in 1797, by William Wallace.

Example 1.3.15. (*Simson's Theorem*)

Given $\triangle ABC$ inscribed in a circle and a point P on its circumference, the perpendiculars dropped from P meet the sides of the triangle in three collinear points.

The line is called the **Simson line** corresponding to P .

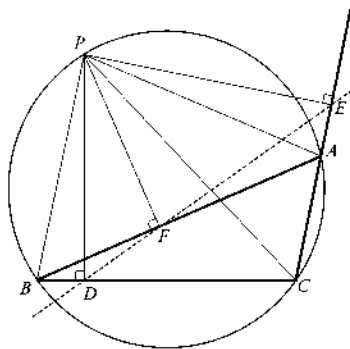

Solution. We will prove Simson's Theorem by showing that $\angle PEF = \angle PED$ (which means that the rays EF and ED coincide).

As well as the cyclic quadrilateral $PACB$, there are two other cyclic quadrilaterals, namely $PEAF$ and $PECD$, which are reproduced in the figure on the following page. (These are cyclic because in each case two of the opposite angles sum to 180°).

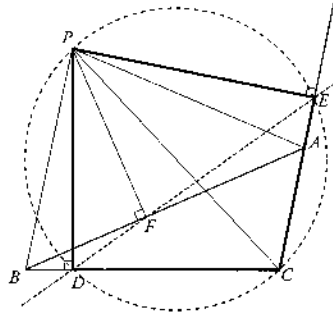
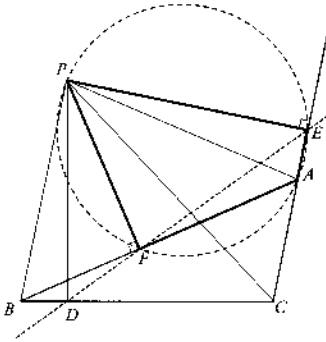

By Thales' Theorem applied to the circumcircle of $PEAF$, we get

$$\angle PEF = \angle PAF = \angle PAB.$$

By Thales' Theorem applied to the circumcircle of $PABC$, we get

$$\angle PAB = \angle PCB = \angle PCD.$$

By Thales' Theorem applied to the circumcircle of $PECD$, we get

$$\angle PCD = \angle PED.$$

Therefore, $\angle PEF = \angle PED$, which completes the proof. □

1.4 More About Congruency

The next theorem follows from ASA congruency together with the fact that the angle sum in a triangle is 180° .

Theorem 1.4.1. (SAA Congruency)

Two triangles are congruent if two angles and a side of one are congruent to two angles and the corresponding side of the other.

In the figure below we have noncongruent triangles ABC and DEF . In these triangles, $AB \cong DE$, $AC \cong DF$, and $\angle B \cong \angle E$. This shows that, in general, SSA does not guarantee congruency.

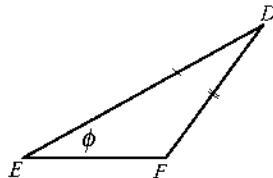
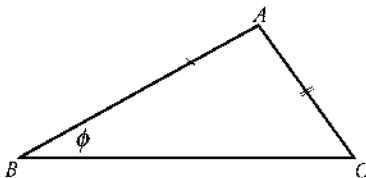

With further conditions we do get congruency:

Theorem 1.4.2. (*SSA⁺ Congruency*)

SSA congruency is valid if the length of the side opposite the given angle is greater than or equal to the length of the other side.

Proof. Suppose that in triangles ABC and DEF we have $AB = DE$, $AC = DF$, and $\angle ABC = \angle DEF$ and that the side opposite the given angle is the larger of the two sides.

We will prove the theorem by contradiction. Assume that the theorem is false, that is, assume that $BC \neq EF$; then we may assume that $BC < EF$. Let H be a point on EF so that $EH = BC$, as in the figure below.

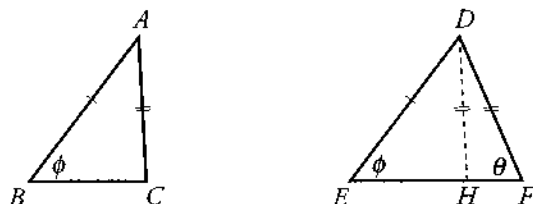

Then, $\triangle ABC \equiv \triangle DEH$ by **SSS** congruency. This means that $DH = DF$, so $\triangle DHF$ is isosceles. Then $\angle DFE = \angle DHF$.

Since we are given that $DF \geq DE$, the Angle-Side Inequality tells us that

$$\angle DEF \geq \angle DFE,$$

and so it follows that $\angle DEF \geq \angle DHF$. However, this contradicts the External Angle Inequality.

We must therefore conclude that the assumption that the theorem is false is incorrect, and so we can conclude that the theorem is true.

□

Since the hypotenuse of a right triangle is always the longest side, there is an immediate corollary:

Corollary 1.4.3. (*HSR Congruency*)

If the hypotenuse and one side of a right triangle are congruent to the hypotenuse and one side of another right triangle, the two triangles are congruent.

Counterexamples and Proof by Contradiction

If we were to say that

If $ABCD$ is a rectangle, then $AB = BC$,

you would most likely show us that the statement is false by drawing a rectangle that is not a square. When you do something like this, you are providing what is called a **counterexample**.

In the assertion “If \mathcal{P} , then \mathcal{Q} ,” the statement \mathcal{P} is called the **hypothesis** and the statement \mathcal{Q} is called the **conclusion**. A counterexample to the assertion is any example in which the hypothesis is true and the conclusion is false.

To prove that an assertion is not true, all you need to do is find a single counterexample. (You do not have to show that it is never true, you only have to show that it is not always true!)

Exercise 1.4.4. For each of the following statements, provide a diagram that is a counterexample to the statement.

1. Given triangle ABC , if $\angle ABC = 60^\circ$, then ABC is isosceles.

2. Given that ABC is an isosceles triangle with $AB = AC$ and with P and Q on side BC as shown in the picture, if $BP = PQ = QC$, then $\angle BAP = \angle PAQ = \angle QAC$.

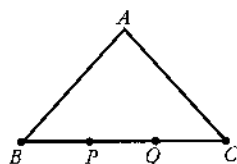

3. In a quadrilateral $ABCD$, if $AB = CD$ and $\angle BAD = \angle ADC = 90^\circ$, then $ABCD$ is a rectangle.

A *proof by contradiction* to verify an assertion of the form “If \mathcal{P} , then \mathcal{Q} ” consists of the following two steps:

- Assume that the assertion is false. This amounts to assuming that there is a counterexample to the assertion; that is, we assume that it is possible for the hypothesis \mathcal{P} to be true while the conclusion \mathcal{Q} is false. In other words, *assume that it is possible for the hypothesis and the negative of the conclusion to simultaneously be true.*
- Show that this leads to a contradiction of a fact that is known to be true. In such circumstances, somewhere along the way an error must have been

made. Presuming that the reasoning is correct, the only possibility is that the assumption that the assertion is false must be in error. Thus, we must conclude that the assertion is true.

1.5 Perpendiculars and Angle Bisectors

Two lines that intersect each other at right angles are said to be *perpendicular* to each other. The *right bisector* or *perpendicular bisector* of a line segment AB is a line perpendicular to AB that passes through the midpoint M of AB .

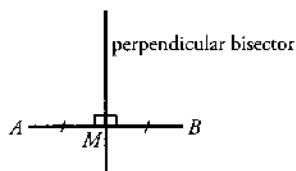

The following theorem is the characterization of the perpendicular bisector.

Theorem 1.5.1. (*Characterization of the Perpendicular Bisector*)

Given different points A and B , the perpendicular bisector of AB consists of all points P that are equidistant from A and B .

Proof. Let P be a point on the right bisector. Then in triangles PMA and PMB we have

$$\begin{aligned} PM &= PM, \\ \angle PMA &= 90^\circ = \angle PMB, \\ MA &= MB, \end{aligned}$$

so triangles PMA and PMB are congruent by **SAS**. It follows that $PA = PB$.

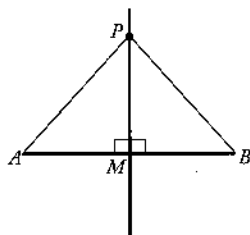

Conversely, suppose that P is some point such that $PA = PB$. Then triangles PMA and PMB are congruent by **SSS**. It follows that $\angle PMA = \angle PMB$, and since the sum of the two angles is 180° , we have $\angle PMA = 90^\circ$. That is, P is on the right bisector of AB . \square

Exercise 1.5.2. *If m is the perpendicular bisector of AB , then A and B are on opposite sides of m . Show that if P is on the same side of m as B , then P is closer to B than to A .*

The following exercise follows easily from Pythagoras' Theorem. Try to do it without using Pythagoras' Theorem.

Exercise 1.5.3. *Show that the hypotenuse of a right triangle is its longest side.*

Exercise 1.5.4. Let l be a line and let P be a point not on l . Let Q be the foot of the perpendicular from P to l . Show that Q is the point on l that is closest to P .

Exercise 1.5.5. Let l be a line and let P be a point not on l . Show that there is at most one line through P perpendicular to l .

Given a nonreflex angle $\angle ABC$, a ray BD such that $\angle ABD = \angle CBD$ is called an **angle bisector** of $\angle ABC$.

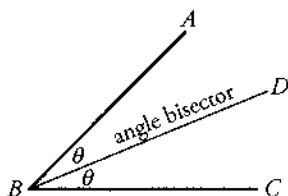

Given a line l and a point P not on l , the **distance** from P to l , denoted $d(P, l)$, is the length of the segment PQ where Q is the foot of the perpendicular from P to l .

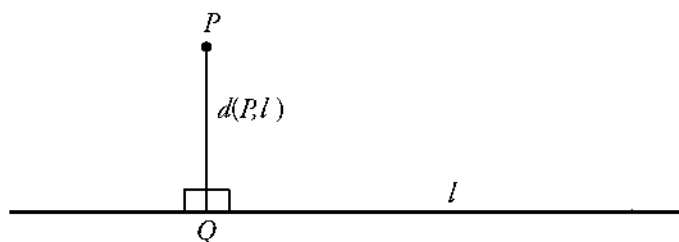

Theorem 1.5.6. (*Characterization of the Angle Bisector*)

The angle bisector of a nonreflex angle consists of all points interior to the angle that are equidistant from the arms of the angle.

Proof. Let P be a point on the angle bisector. Let Q and R be the feet of the perpendiculars from P to AB and CB , respectively. Triangles PQB and PRB have the side PB in common,

$$\angle PQB = \angle PRB \quad \text{and} \quad \angle PBQ = \angle PBR.$$

Thus, the triangles are congruent by **SAA**, hence $PQ = PR$. Therefore, P is equidistant from AB and CB .

Conversely, let P be a point that is equidistant from BA and BC . Let Q and R be the feet of the perpendiculars from P to AB and CB , respectively, so that $PQ = PR$. Thus, triangles PQB and PRB are congruent by **HSR**, and it follows that

$$\angle PBA = \angle PBQ = \angle PBR = \angle PBC.$$

Hence, P is on the angle bisector of $\angle ABC$.

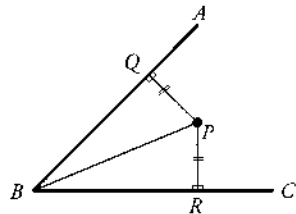
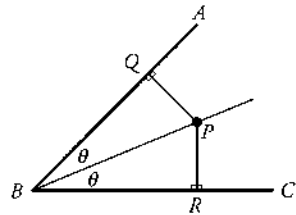

□

Inequalities in Proofs

Before turning to construction problems, we list the inequalities that we have used in proofs and add one more to the list.

1. Triangle Inequality
2. Exterior Angle Inequality
3. Angle-Side Inequality
4. Open Jaw Inequality

This last inequality is given in the following theorem.

Theorem 1.5.7. (*Open Jaw Inequality*)

Given two triangles $\triangle ABC$ and $\triangle DEF$ with $AB = DE$ and $BC = EF$. Then $\angle ABC < \angle DEF$ if and only if $AC < DF$, as in the figure.

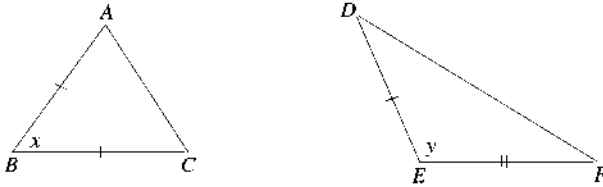

Proof. Suppose that $x < y$. Then we can build x in $\triangle DEF$ so that $EG = AB$. G can be inside or on the triangle. Here, we assume that G is outside $\triangle DEF$, as in the figure below.

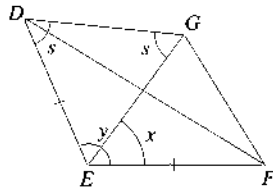

Now note that $\triangle ABC \cong \triangle GEF$ by the **SAS** congruency theorem, and $\triangle EDG$ is isosceles with angles as shown. Also, $s < \angle DGF$, since GE is interior to $\angle G$, and $s > \angle GDF$, since DF is interior to $\angle D$. Therefore,

$$\angle DGF > s > \angle GDF,$$

and by the Angle-Side Inequality, this implies that

$$DF > GF = AC.$$

Now suppose that $AC < DF$. Then exactly one of the following is true:

$$x = y \quad \text{or} \quad x > y \quad \text{or} \quad x < y$$

(this is called the **law of trichotomy** for the real number system).

If $x = y$, then $\triangle ABC \cong \triangle DEF$ by the **SAS** congruency theorem, which is a contradiction since we are assuming that $AC < DF$.

If $x > y$, then by the first part of the theorem we would have $AC > DF$, which is also a contradiction.

Therefore, the only possibility left is that $x < y$, and we are done.

□

1.6 Construction Problems

Although there are many ways to physically draw a straight line, the image that first comes to mind is a pencil sliding along a ruler. Likewise, the draftsman's compass comes to mind when one thinks of drawing a circle. To most people, the words *straightedge* and *compass* are synonymous with these physical instruments. In geometry, the same words are also used to describe idealized instruments. Unlike their physical counterparts, the geometric straightedge enables us to draw a line of arbitrary length, and the geometric compass allows us to draw arcs and circles of any radius we please. When doing geometry, you should regard the physical straightedge and compass as instruments that mimic the “true” or “idealized” instruments.

There is a reason for dealing with idealized instruments rather than physical ones. Mathematics is motivated by a desire to look at the basic essence of a problem, and to achieve this we have to jettison any unnecessary baggage. For example, we do not want to worry about the problem of the thickness of the pencil line, for this is a drafting problem rather than a geometry problem. However, as we strip away the unnecessary limitations of the draftsman's straightedge and compass, the effect is to create versions of the instruments that behave somewhat differently from their physical counterparts.

The idealized instruments are not “real,” nor are the lines and circles that they draw. As a consequence, we cannot appeal to the properties of the physical instruments as verification for whatever we do in geometry. In order to work with idealized instruments, it is important to describe very clearly what they can do. The rules for the abstract instruments closely resemble the properties of the physical ones:

Straightedge Operations

A straightedge can be used to draw a straight line that passes through two given points.

Compass Operations

A compass can be used to draw an arc or circle centered at a given point with a given distance as radius. (The given distance is defined by two points.)

These two statements completely describe how the straightedge and compass operate, and there are no further restrictions, nor any additional properties. For example, the most common physical counterpart of the straightedge is a ruler, and it is a fairly easy matter to place a ruler so that the line to be drawn appears to be tangent to a given physical circle. With the true straightedge, this operation is forbidden. If you wish to draw a tangent line, you must first find two points on the line and then use the straightedge to draw the line through these two points.

A ruler has another property that the straightedge does not. It has a scale that can be used for measuring. A straightedge has no marks on it at all and so cannot be used as a measuring device.

We cannot justify our results by appealing to the physical properties of the instruments. Nevertheless, experimenting with the physical instruments sometimes leads to an understanding of the problem at hand, and if we restrict the physical instruments so that we only use the two operations described above, we are seldom led astray.

Useful Facts in Justifying Constructions

Recall that a *rhombus* is a parallelogram whose sides are all congruent, as in the figure on the right.

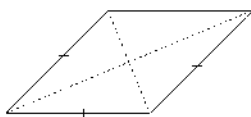

A *kite* is a convex quadrilateral with two pairs of adjacent sides congruent. Note that the diagonals intersect in the interior of the kite.

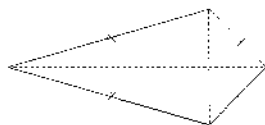

A *dart* is a nonconvex quadrilateral with two pairs of adjacent sides congruent. Note that the diagonals intersect in the exterior of the dart.

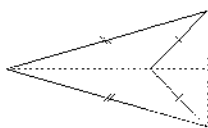

Theorem 1.6.1.

- (1) *The diagonals of a parallelogram bisect each other.*
- (2) *The diagonals of a rhombus bisect each other at right angles.*
- (3) *The diagonals (possibly extended) of a kite or a dart intersect at right angles.*

Basic Constructions

The first three basic constructions are left as exercises.

Exercise 1.6.2. *To construct a triangle given two sides and the included angle.*

Exercise 1.6.3. *To construct a triangle given two angles and the included side.*

Exercise 1.6.4. *To construct a triangle given three sides.*

Example 1.6.5. To copy an angle.

Solution. Given $\angle A$ and a point D , we wish to construct a congruent angle FDE .

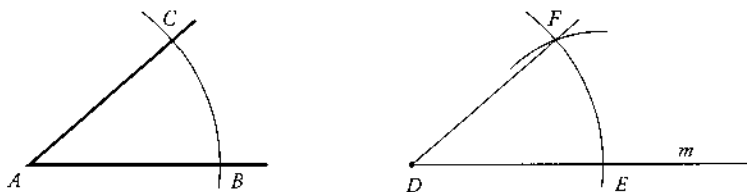

Draw a line m through the point D .

With center A , draw an arc cutting the arms of the given angle at B and C .

With center D , draw an arc of the same radius cutting m at E .

With center E and radius BC , draw an arc cutting the previous arc at F .

Then, $\angle FDE \equiv \angle A$.

Since triangles BAC and EDF are congruent by **SSS**, $\angle BAC \equiv \angle EDF$.

□

Example 1.6.6. To construct the right bisector of a segment.

Solution. Given points A and B , with centers A and B , draw two arcs of the same radius meeting at C and D . Then CD is the right bisector of AB .

To see this, let M be the point where CD meets AB . First, we note that $\triangle ACD \equiv \triangle BCD$ by **SSS**, so $\angle ACD = \angle BCD$. Then in triangles ACM and BCM we have

$$\begin{aligned} AC &= BC, \\ \angle ACM &= \angle BCM, \\ CM &\text{ is common,} \end{aligned}$$

so $\triangle ACM \equiv \triangle BCM$ by **SAS**. Then

$$AM = BM \quad \text{and} \quad \angle AMC = \angle BMC = 90^\circ,$$

which means that CM is the right bisector of AB .

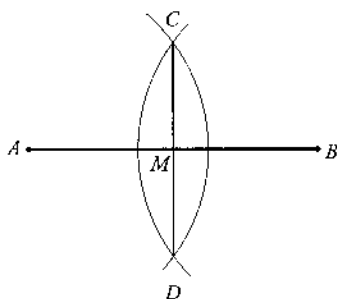

□

Example 1.6.7. To construct a perpendicular to a line from a point not on the line.

Solution. Let the point be P and the line be m .

With center P , draw an arc cutting m at A and B . With centers A and B , draw two arcs of the same radius meeting at Q , where $Q \neq P$. Then PQ is perpendicular to m .

Since by construction both P and Q are equidistant from A and B , both are on the right bisector of the segment AB , and hence PQ is perpendicular to m .

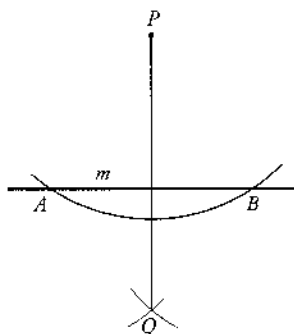

□

Example 1.6.8. To construct the angle bisector of a given angle.

Solution. Let P be the vertex of the given angle. With center P , draw an arc cutting the arms of the angle at S and T . With centers S and T , draw arcs of the same radius meeting at Q . Then PQ is the bisector of the given angle.

Since triangles SPQ and TPQ are congruent by SSS, $\angle SPQ = \angle TPQ$.

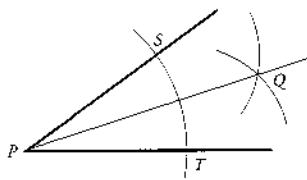

□

Exercise 1.6.9. To construct a perpendicular to a line from a point on the line.

1.6.1 The Method of Loci

The *locus* of a point that “moves” according to some condition is the traditional language used to describe the set of points that satisfy a given condition. For example, the locus of a point that is equidistant from two points A and B is the set of all points that are equidistant from A and B — in other words, the right bisector of AB .

The most basic method used to solve geometric construction problems is to locate important points by using the intersection of loci, which is usually referred to as the *method of loci*. We illustrate with the following:

Example 1.6.10. Given two intersecting lines l and m and a fixed radius r , construct a circle of radius r that is tangent to the two given lines.

Solution. It is often useful to sketch the expected solution. We refer to this sketch as an *analysis figure*. The more accurate the sketch, the more useful the figure. In the analysis figure you should attempt to include all possible solutions. The analysis figure for Example 1.6.10 is as follows, where l and m are the given lines intersecting at P .

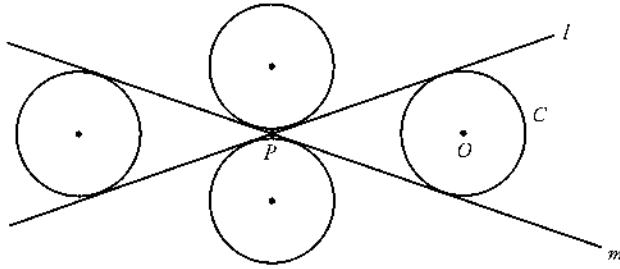

The analysis figure indicates that there are four solutions. The constructions of all four solutions are basically the same, so in this case it suffices to show how to construct one of the four circles.

Since we are given the radius of the circle, it is enough to construct O , the center of circle C . Since we only have a straightedge and a compass, there are only three ways to construct a point, namely, as the intersection of

- two lines,
- two circles, or
- a line and a circle.

The center O of circle C is equidistant from both l and m and therefore lies on the following constructible loci:

1. an angle bisector,
2. a line parallel to l at distance r from l ,
3. a line parallel to m at distance r from m .

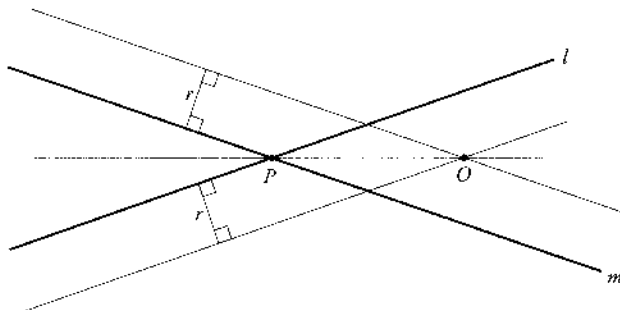

Any two of these loci determine the point O .

Having done the analysis, now write up the solution:

1. Construct line n parallel to l at distance r from l .
2. Construct line k parallel to m at distance r from m .
3. Let $O = n \cap k$.
4. With center O and radius r , draw the circle $\mathcal{C}(O, r)$.

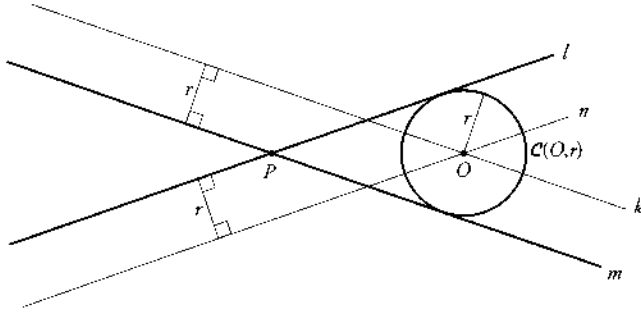

□

1.7 Solutions to Selected Exercises

Solution to Exercise 1.2.8

1. *Statement:* Given triangle ABC , if $\angle ABC$ is a right angle, then

$$AB^2 + BC^2 = AC^2.$$

Converse: Given triangle ABC , if

$$AB^2 + BC^2 = AC^2,$$

then $\angle ABC$ is a right angle.

Both the statement and its converse are true.

2. *Statement:* If $ABCD$ is a parallelogram, then $AB = CD$ and $AD = BC$.
Converse: If $AB = CD$ and $AD = BC$, then $ABCD$ is a parallelogram.

The statement is true and the converse is false.

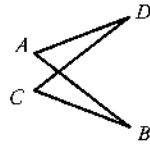

3. *Statement:* If $ABCD$ is a convex quadrilateral, then $ABCD$ is a rectangle.
Converse: If $ABCD$ is a rectangle, then $ABCD$ is a convex quadrilateral.

The statement is false and the converse is true.

4. *Statement:* Given quadrilateral $ABCD$, if $AC \neq BD$, then $ABCD$ is not a rectangle.
Converse: Given quadrilateral $ABCD$, if $ABCD$ is not a rectangle, then $AC \neq BD$.

The statement is true and its converse is false.

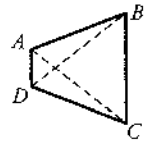

Solution to Exercise 1.3.9

In the figure below, we have $\alpha = 30$ (isosceles triangle).

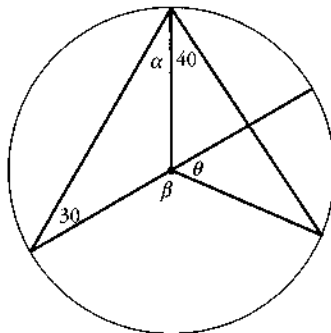

Thus, by Thales' Theorem,

$$\beta = 2(\alpha + 40) = 140,$$

so that $\theta = 180 - \beta = 40$.

Solution to Exercise 1.3.14

Suppose that the quadrilateral $ABCD$ has an inscribed circle that is tangent to the sides at points P , Q , R , and S , as shown in the figure.

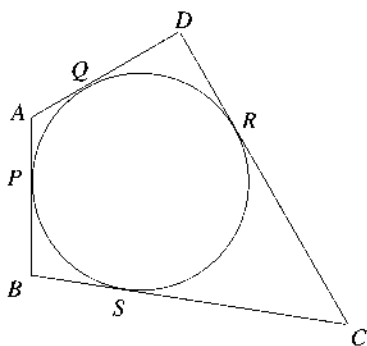

Since the tangents to the circle from an external point have the same length, then

$$AP = AQ, \quad PB = BS$$

and

$$SC = CR, \quad RD = QD,$$

so that

$$\begin{aligned} AB + CD &= AP + PB + CR + RD \\ &= AQ + BS + SC + QD \\ &= (AQ + QD) + (BS + SC) \\ &= AD + BC. \end{aligned}$$

Conversely, suppose that $AB + CD = AD + BC$, and suppose that the extended sides AD and BC meet at X . Introduce the incircle of $\triangle DXC$, that is, the circle internally tangent to each of the sides of the triangle, and suppose that it is not tangent to AB . Let E and F be on sides AD and BC , respectively, such that EF is parallel to AB and tangent to the incircle, as in the figure.

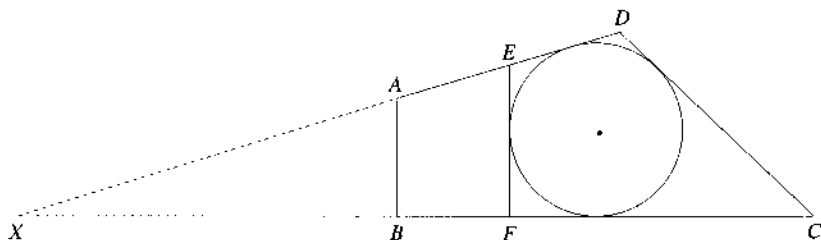

Solution to Exercise 1.4.4

1.

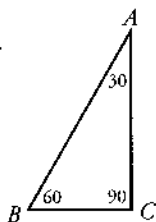

2. The assertion is always false.

3.

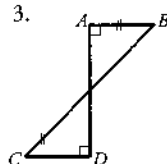

Solution to Exercise 1.5.2

In the figure below, we have

$$PB < PQ + QB = PQ + QA = PA.$$

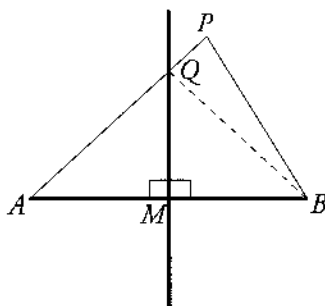

Solution to Exercise 1.5.3

Here are two different solutions.

1. The right angle is the largest angle in the triangle (otherwise the sum of the three angles of the triangle would be larger than 180°). Since the hypotenuse is opposite the largest angle, it must be the longest side.
2. In the figure below, suppose that B is the right angle.

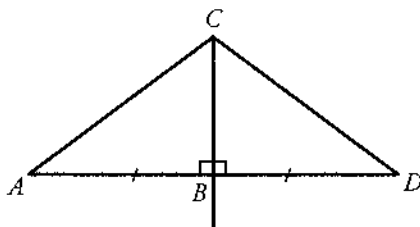

Extend AB beyond B to D so that $BD = AB$. Then C is on the right bisector of AD , so

$$AC = \frac{1}{2}(AC + CD) > \frac{1}{2}AD = AB.$$

This shows that $AC > AB$, and in a similar fashion it can be shown that $AC > CB$.

Solution to Exercise 1.5.4

Let Q be the foot of the perpendicular from P to the line l , and let R be any other point on l . Then $\triangle PQR$ is a right triangle, and by Exercise 1.5.3, $PR > PQ$.

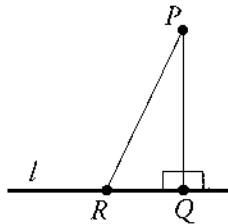

1.8 Problems

1. Prove that the internal and external bisectors of the angles of a triangle are perpendicular.
2. Let P be a point inside $\mathcal{C}(O, r)$ with $P \neq O$. Let Q be the point where the ray \overrightarrow{OP} meets the circle. Use the Triangle Inequality to show that Q is the point on the circle that is closest to P .
3. Let P be a point inside $\triangle ABC$. Use the Triangle Inequality to prove that $AB + BC > AP + PC$.
4. Each of the following statements is true. State the converse of each statement, and if it is false, provide a figure as a counterexample.
 - (a) If $\triangle ABC \cong \triangle DEF$, then $\angle A = \angle D$ and $\angle B = \angle E$.
 - (b) If $ABCD$ is a rectangle, then $\angle A = \angle C = 90^\circ$.
 - (c) If $ABCD$ is a rectangle, then $\angle A = \angle B = \angle C = 90^\circ$.
5. Given the isosceles triangle ABC with $AB = AC$, let D be the foot of the perpendicular from A to BC . Prove that AD bisects $\angle BAC$.

6. Show that if the perpendicular from A to BC bisects $\angle BAC$, then $\triangle ABC$ is isosceles.
7. D is a point on BC such that AD is the bisector of $\angle A$. Show that

$$\angle ADC = 90 + \frac{\angle B - \angle C}{2}.$$

8. Construct an isosceles triangle ABC , given the unequal angle $\angle A$ and the length of the side BC .
9. Construct a right triangle given the hypotenuse and one side.
10. Calculate θ in the following figure.

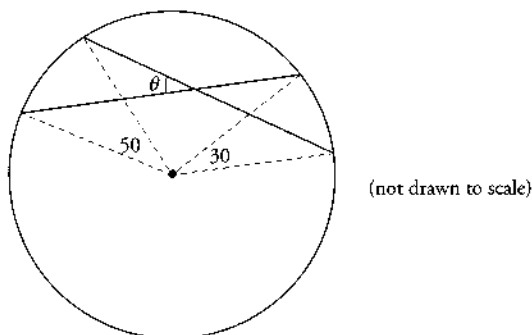

11. Let Q be the foot of the perpendicular from a point P to a line l . Show that Q is the point on l that is closest to P .
12. Let P be a point inside $\mathcal{C}(O, r)$ with $P \neq O$. Let Q be the point where the ray \overrightarrow{PO} meets the circle. Show that Q is the point of the circle that is farthest from P .
13. Let $ABCD$ be a simple quadrilateral. Show that $ABCD$ is cyclic if and only if the opposite angles sum to 180° .
14. Draw the locus of a point whose sum of distances from two fixed perpendicular lines is constant.

15. Given a circle $C(P, s)$, a line l disjoint from $C(P, s)$, and a radius r ($r > s$), construct a circle of radius r tangent to both $C(P, s)$ and l .

Note: The analysis figure indicates that there are four solutions.

