

1

Asymptotic Approaches

Asymptotic analysis is a constantly growing branch of mathematics which influences the development of various pure and applied sciences. The famous mathematicians Friedrichs [109] and Segel [217] said that an asymptotic description is not only a suitable instrument for the mathematical analysis of nature but that it also has an additional deeper intrinsic meaning, and that the asymptotic approach is more than just a mathematical technique; it plays a rather fundamental role in science. And here it appears that the many existing asymptotic methods comprise a set of approaches that in some way belong rather to art than to science. Kruskal [151] even introduced the special term “asymptotology” and defined it as the art of handling problems of mathematics in extreme or limiting cases. Here it should be noted that he called for a formalization of the accumulated experience to convert the art of asymptotology into a science of asymptotology.

Asymptotic methods for solving mechanical and physical problems have been developed by many authors. We can mention excellent monographs by Eckhaus [96], [97], Hinch [133], Holms [134], Kevorkian and Cole [147], Lin and Segel [162], Miller [188], Nayfeh [62], [63], Olver [197], O’Malley [198], Van Dyke [244], [246], Verhulst [248], Wasov [90] and many others [15], [20], [34], [71], [72], [110], [119], [161], [169], [173]–[175], [216], [222], [223], [250], [251]. The main feature of the present book can be formulated as follows: it deals with new trends and applications of asymptotic approaches in the fields of Nonlinear Mechanics and Mechanics of Solids. It illuminates developments in the field of asymptotic mathematics from different viewpoints, reflecting the field’s multidisciplinary nature. The choice of topics reflects the authors’ own research experience and participation in applications. The authors have paid special attention to examples and discussions of results, and have tried to avoid burying the central ideas in formalism, notations, and technical details.

1.1 Asymptotic Series and Approximations

1.1.1 Asymptotic Series

As has been mentioned by Dingle [92], theory of asymptotic series has just recently made remarkable progress. It was achieved through the seminal observation that application of

asymptotic series is tightly linked with the choice of a summation procedure. A second natural question regarding the method of series summation emerges. It is widely known that only in rare cases does a simple summation of the series terms lead to satisfactory and reliable results. Even in the case of convergent series, many problems occur, which increase essentially in the case of a study of divergent series [64]. In order to clarify the problems mentioned so far, let us consider the general form of an asymptotic series widely used in physics and mechanics [65]:

$$\sum_{n=1}^{\infty} M_n \left(\frac{\varepsilon}{\varepsilon_0} \right)^n \Gamma(n+a), \quad (1.1)$$

where a denotes an integer, and Γ is a Gamma function (see [2], Chapter 6).

The quantity ε_0 is often referred to as a singulant, and M_n denotes a modifying factor. The sequence M_n tends to a constant for $n \rightarrow \infty$ and yields information on the slowly changed series part, whereas the constant ε_0 is associated with the first singular point of the initially studied either integral or differential equation linked to the series (1.1).

In what follows we recall the classical definition: a power type series is the asymptotic series regarding the function $f(\varepsilon)$, if for a fixed N and essentially small $\varepsilon > 0$, the following relation holds

$$\left| f(x) - \sum_{j=0}^N a_j \varepsilon^j \right| \sim O(\varepsilon^{N+1}),$$

where the symbol $O(\varepsilon^{N+1})$ denotes the accuracy order of ε^{N+1} (see Section 1.2).

In other words we study the interval for $\varepsilon \rightarrow 0$, $N = N_0$.

Although series (1.1) is divergent for $\varepsilon \neq 0$, its first terms vanish exponentially fast for $\varepsilon \ll \varepsilon_0$. This underscores an important property of asymptotic series, related to a game between decaying terms and factorial increase of coefficients. An optimal accuracy is achieved if one takes a smallest term of the series, and then the corresponding error achieves $\exp(-\alpha/\varepsilon)$, where $\alpha > 0$ is the constant, and ε is the small/perturbation parameter. Therefore, a truncation of the series up to its smallest term yields the exponentially small error with respect to the initial value problem. On the other hand, sometimes it is important to include the above-mentioned exponentially small terms from a computational point of view, since it leads to improvement of the real accuracy of an asymptotic solution [52], [53], [64], [65], [226], [230].

Let us consider the following Stieltjes function (see [65]):

$$S(\varepsilon) = \int_0^{\infty} \frac{\exp(-t)}{1 + \varepsilon t} dt. \quad (1.2)$$

Postulating the approximation

$$\frac{1}{1 + \varepsilon t} = \sum_{j=0}^N (-\varepsilon t)^j + \frac{(-\varepsilon t)^{N+1}}{1 + \varepsilon t}, \quad (1.3)$$

and putting series (1.3) into integral (1.2) we get

$$S(\varepsilon) = \sum_{j=0}^N (-\varepsilon^j) \int_0^{\infty} t^j \exp(-t) dt + E_N(\varepsilon), \quad (1.4)$$

where

$$E_N(\varepsilon) = \int_0^{\infty} \frac{\exp(-t)(-\varepsilon t)^{N+1}}{1 + \varepsilon t} dt. \quad (1.5)$$

Computation of integrals in Equation (1.4) using integration by parts yields

$$S(\varepsilon) = \sum_{j=0}^N (-1)^j j! \varepsilon^j + E_N(\varepsilon).$$

If N tends to infinity, then we get a divergent series. It is clear, since the under integral functions have a simple pole in the point $t = -1/\varepsilon$, therefore series (1.3) is valid only for $|t| < 1/\varepsilon$. The obtained results cannot be applied in the whole interval $0 \leq t < \infty$.

Let us estimate an order of divergence by splitting the function $S(\varepsilon)$ into two parts, i.e.

$$S(\varepsilon) = S_1(\varepsilon) + S_2(\varepsilon) = \int_0^{1/\varepsilon} \frac{\exp(-t)}{1 + \varepsilon t} dt + \int_{1/\varepsilon}^{\infty} \frac{\exp(-t)}{1 + \varepsilon t} dt.$$

Since $1/(1 + \varepsilon t) \leq 1/2$ for $t > 1/\varepsilon$, the following estimation is obtained: $S_2(\varepsilon) < 0.5 \exp(-1/\varepsilon)$.

Therefore, the exponential decay of the error is observed for decreasing ε , which is a typical property of an asymptotic series.

Let us now estimate an optimal number of series terms. This corresponds to the situation in which the term $t^{N+1} \exp(-t)$ in Equation (1.4) is a minimal one, which holds for $t = 1/(N + 1)$. For $t \geq 1/\varepsilon$ we observe the divergence, and this yields the following estimation: $N = [1/\varepsilon]$, where $[\dots]$ denotes an integer part of the number. The optimally truncated series is called the super-asymptotic one [65], whereas the hyperasymptotic series [52], [53] refers to the series with the accuracy barrier overcome. It means that after the truncation procedure one needs novel ideas to increase accuracy of the obtained results. Problems regarding a summation of divergent series are discussed in Chapters 1.3–1.5.

One may, for instance, transform the series part

$$S(\varepsilon) \approx \sum_{j=0}^{2N} (-1)^j j! \varepsilon^j \quad (1.6)$$

into the PA, i.e. into a rational function of the form

$$S(\varepsilon) \approx \frac{1 + \sum_{j=1}^N \alpha_j \varepsilon^j}{1 + \sum_{i=1}^N \beta_i \varepsilon^i}, \quad (1.7)$$

where constants α_j, β_i are chosen in a such a way that first $2N + 1$ terms of the MacLaurin series (1.7) coincide with the coefficients of series (1.6). It has been proved that a sequence of PA (1.7) is convergent into a Stieltjes integral, and the error related to estimation of $S(\varepsilon)$ decreases proportionally to $\exp(-4\sqrt{N/\varepsilon})$.

The definition of an asymptotic series indicates a way of numerical validation of an asymptotic series [62]. Let us for instance assume that the solution $U_a(\varepsilon)$ is the asymptotic of the exact solution $U_T(\varepsilon)$, i.e.

$$E = U_T(\varepsilon) - U_a(\varepsilon) = K\varepsilon^\alpha.$$

One may take as U_T a numerical solution. In order to define α , usually graphs of the dependence $\ln E$ versus $\ln \varepsilon$ for different values of ε are constructed. The associated relations should be closed to linear ones, whereas the constant α can be defined using the method of least squares. However, for large ε the asymptotic property of the solution is not clearly exhibited, whereas for small ε values it is difficult to get a reliable numerical solution. Let us study an example of the following integral

$$I(\varepsilon) = \varepsilon e^\varepsilon \int_\varepsilon^\infty \frac{e^{-t}}{t} dt$$

for large values of ε . Although the infinite series

$$I(\varepsilon) = \sum_{n=0}^{\infty} \frac{(-1)^n n!}{\varepsilon^n}$$

is divergent for all values of ε , series parts

$$I_M(\varepsilon) = \sum_{n=0}^M \frac{(-1)^n n!}{\varepsilon^n} \quad (1.8)$$

are asymptotically equivalent up to the order of $O(\varepsilon^{-M})$ with the error of $O(\varepsilon^{-M-1})$ for $x \rightarrow \infty$. In Figure 1.1 the dependence $\log E_M(\varepsilon)$ vs. $\log \varepsilon$, where $E_M(\varepsilon) = I(\varepsilon) - I_M(\varepsilon)$, is reported (curves going down correspond to decreasing values of $M = 1, \dots, 5$).

It is clear that curve slopes are different. However, results reported in Table 1.1 of the least square method fully prove the high accuracy of the method applied.

Let us briefly recall the method devoted to finding asymptotic series, where the function values are known in a few points. Let a numerical solution be known for some values of the parameter $\varepsilon: f(\varepsilon_1), f(\varepsilon_2), f(\varepsilon_3)$. If we know a priori that the solution is of an asymptotic-type,

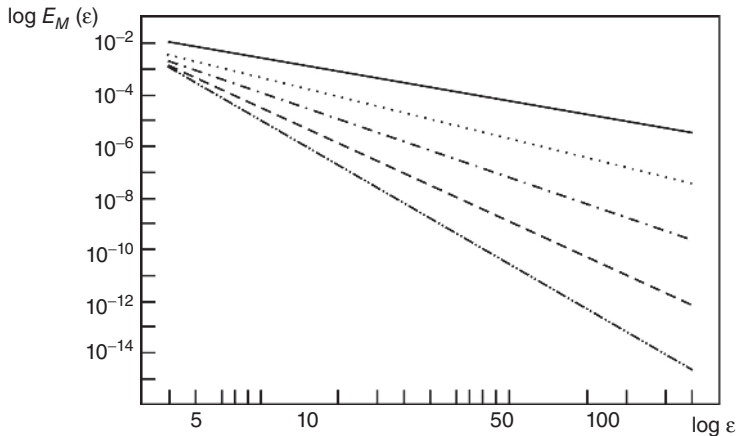

Figure 1.1 Asymptotic properties of partial sums of (1.8)

Table 1.1 Slope coefficient $\log E_M(\varepsilon)$ as the function of $\log \varepsilon$ defined via the least square method

$E_M(\varepsilon)$	$\varepsilon \in [5, 50]$	$\varepsilon \in [50, 200]$	$\varepsilon \in [200, 500]$	slope
1	-1.861	-1.972	-1.991	-2.0
2	-2.823	-2.963	-2.988	-3.0
3	-3.789	-3.954	-3.985	-4.0
4	-4.758	-4.945	-4.981	-5.0
5	-5.729	-5.937	-5.999	-6.0

and its general properties are known (for instance it is known that the series corresponds only to integer values of ε), then the following approximation holds

$$f(\varepsilon_i) = \sum_{i=0}^3 \varepsilon^i a_i,$$

and the coefficients a_i can be easily identified. The latter approach can be applied in the following briefly addressed case. In many cases it is difficult to obtain a solution regarding small values of ε , whereas it is easy to find it for ε of order 1. Furthermore, assume that we know a priori the solution asymptotic for $\varepsilon \rightarrow 0$, but it is difficult or unnecessary to define it analytically. In this case the earlier presented method can be applied directly.

1.1.2 Asymptotic Symbols and Nomenclatures

In this section we introduce basic symbols and a nomenclature of the asymptotic analysis considering the function $f(x)$ for $x \rightarrow x_0$. In the asymptotic approach we focus on monitoring the function $f(x)$ behavior for $x = x_0$. Namely, we are interested in finding another arbitrary function $\varphi(x)$ being simpler than the original (exact) one, which follows $f(x)$ for $x \rightarrow x_0$ with increasing accuracy. In order to compare both functions, a notion of the order of a variable quantity is introduced accompanied by the corresponding relations and symbols.

We say that the function $f(x)$ is of order $\varphi(x)$ for $x \rightarrow x_0$, or equivalently

$$f(x) = O(\varphi(x)) \quad \text{for} \quad x \rightarrow x_0,$$

if there is a number A , such that in a certain neighborhood Δ of the point x_0 we have $|f(x)| \leq A|\varphi(x)|$.

Besides, we say that $f(x)$ is the quantity of an order less than $\varphi(x)$ for $x \rightarrow x_0$, or equivalently

$$f(x) = o(\varphi(x)) \quad \text{for} \quad x \rightarrow x_0,$$

if for an arbitrary $\varepsilon > 0$ we find a certain neighborhood Δ of the point x_0 , where $|f(x)| \leq \varepsilon|\varphi(x)|$.

In the first case the ratio $|f(x)|/|\varphi(x)|$ is bounded in Δ , whereas in the second case it tends to zero for $x \rightarrow x_0$. For example, $\sin x = O(1)$ for $x \rightarrow \infty$; $\ln x = o(x^\alpha)$ for an arbitrary $\alpha > 0$ for $x \rightarrow \infty$.

Symbols $O(\dots)$ and $o(\dots)$ are often called Landau's symbols (see [62], [63]). It should be emphasized that Edmund Landau introduced these symbols in 1909, whereas Paul Gustav Heinrich Bachman had already done so in 1894. Sometimes it worthwhile to apply additional symbols introducing other ordering relations. Namely, if $f(x) = O(\varphi(x))$, but $f(x) \neq o(\varphi(x))$ for $x \rightarrow x_0$, then the following notation holds $f(x) = \tilde{O}(\varphi(x))$ for $x \rightarrow x_0$, where the symbol $\tilde{O}(\varphi(x))$ is called the symbol of the exact order (note that in some cases also the following symbol is applied $Oe(\varphi(x))$). If $f(x) = O(\varphi(x))$, $\varphi(x) = O(f(x))$ for $x \rightarrow x_0$, (it means that $f(x)$ asymptotically equals to $\varphi(x)$ for $x \rightarrow x_0$), which is abbreviated by the notation $f(x) \asymp \varphi(x)$ for $x \rightarrow x_0$. Recall that in some cases the symbol \asymp is used. Asymptotic relations give rights for the existence of the numbers $a > 0$ and $A > 0$, where in the vicinity of the point x_0 the following approximation holds: $a|\varphi(x)| \leq |f(x)| \leq A|\varphi(x)|$.

Symbols \tilde{O} and \asymp might be expressed by O , o and are used only for a brief notation. One may distinguish the following steps while constructing an asymptotic approximation. In the beginning high (low) order estimations are constructed of the type $f(x) = O(\varphi(x))$. Usually this first approximation is overestimated, i.e. we have $f(x) = O(\varphi(x))$.

In order to improve this first approximation the following exact order is applied $f(x) = \tilde{O}(\varphi_0(x))$, and the following asymptotic approximation is achieved $f(x) \sim a_0\varphi_0(x)$. Carrying out this kind of a cycle, we may get the asymptotic chain $f(x) - a_0\varphi_0(x) \sim a_1\varphi_1(x)$, and go further with the introduced analysis. We say that the sequence $\{\varphi_n(x)\}$, $n = 0, 1, \dots$ for $x \rightarrow x_0$ is an asymptotic one, if $\varphi_{n+1}(x) = o(\varphi_n(x))$. For instance, the following sequence $\{x^n\}$ is an asymptotic one for $x \rightarrow 0$.

A series $\sum_{n=0}^{\infty} a_n\varphi_n(x)$ with constant coefficients is called an asymptotic one, if $\{\varphi_n(x)\}$ is an asymptotic sequence. We say that $f(x)$ has an asymptotic series with respect to the sequence $\{\varphi_n(x)\}$, or equivalently

$$f(x) \sim \sum_{n=0}^N a_n\varphi_n(x), \quad N = 0, 1, 2, \dots, \quad (1.9)$$

if

$$f(x) = \sum_{n=0}^m a_n\varphi_n(x) + o(\varphi_m(x)), \quad m = 0, 1, 2, \dots, N. \quad (1.10)$$

Let us investigate the uniqueness of the asymptotic series. Let the function $f(x)$ for $x \rightarrow x_0$ be developed into a series with respect to the asymptotic sequence $\{\varphi_n(x)\}$, $f(x) \sim \sum_{n=0}^{\infty} a_n\varphi_n(x)$. Then the coefficients a_n are defined uniquely via the following formula

$$a_n = \lim_{x \rightarrow x_0} \left[f(x) - \sum_{k=0}^{n-1} a_k\varphi_k(x) \right] \varphi_n^{-1}(x).$$

Observe that the same function $f(x)$ can be developed with respect to another sequence $\chi_n(x)$, for instance

$$\frac{1}{1-x} \sim \sum_{n=0}^{\infty} x^n \quad \text{for } x \rightarrow 0; \quad \frac{1}{1-x} \sim \sum_{n=0}^{\infty} (1+x)x^{2n} \quad \text{for } x \rightarrow 0.$$

On the other hand, one asymptotic series may correspond to a few functions, for instance

$$\frac{1 + e^{-1/x}}{1 - x} \sim \sum_{n=0}^{\infty} x^n \quad \text{for } x \rightarrow 0.$$

In other words an asymptotic series represents a class of asymptotically equivalent functions. The latter property can be applied directly in many cases (see Chapter 1.5).

Asymptotic expansion of functions $f(x)$ and $g(x)$ for $x \rightarrow x_0$ regarding the sequence $\{\varphi_n(x)\}$ follows

$$f(x) \sim \sum_{n=0}^{\infty} a_n \varphi_n(x), \quad g(x) \sim \sum_{n=0}^{\infty} b_n \varphi_n(x),$$

and the following property holds

$$\alpha f(x) + \beta g(x) \sim \sum_{n=0}^{\infty} (\alpha a_n + \beta b_n) \varphi_n(x).$$

In general, a direct multiplication of the series $\{\varphi_n(x) \cdot \varphi_m(x)\}$ ($m, n = 0, 1, \dots$) is not allowed, since they sometimes cannot be ordered into an asymptotic sequence. However, it can be done, for instance, in the case $\varphi_n(x) = x^n$. Power series allow division if $b_0 \neq 0$.

Finding logarithms is generally allowed. For instance, let us consider the function $f(x) = (\sqrt{x} \ln x + 2x)e^x$, for which the following relation holds

$$f(x) = [2x + o(x)]e^x \quad \text{for } x \rightarrow \infty. \quad (1.11)$$

Let $g(x) = \ln[f(x)]$, then according to (1.11), we have

$$g(x) = x + \ln[2x + o(x)] = x + \ln x + \ln 2 + o(1) \sim x + o(x) \quad \text{for } x \rightarrow \infty.$$

Raising $g(x)$ to a power we find $f(x) \sim e^x$ for $x \rightarrow \infty$. Note that the multiplier $2x$ is lost. The reason is that the carried out involution in series approximation of $g(x)$ does not include terms $\ln x$ and $\ln 2$ acting on the main term of the asymptotic of $f(x)$, and only the quantities of order $o(1)$ do not change the coefficient, since $\exp\{o(1)\} \sim 1$.

The power form asymptotic series

$$f(x) \sim \sum_{n=2}^{\infty} a_n x^{-n} \quad \text{for } x \rightarrow \infty,$$

may be integrated step by step. Differentiation of asymptotic series are not allowed in general. For example, the function

$$f(x) = e^{-1/x} \sin(e^{-1/x})$$

possesses the following singular power form series

$$f(x) \sim 0 \cdot 1 + 0 \cdot x + 0 \cdot x^2 + \dots,$$

whereas the associated derivative of the function $f(x)$ does not allow a power type series development. If the function $f(x)$ and its continuous derivative $f'(x)$ for $x \geq d > 0$ possess a power type asymptotic series for $x \rightarrow \infty$, then this derivative can be obtained via step by step differentiation of the series terms of the function $f(x)$.

Let us emphasize that the majority of errors regarding the application of asymptotic methods occur through incorrect change of orders of limiting transitions and differentiations (see [244]). This remark is followed by an example. Let the method of Bubnov-Galerkin be applied for a thin-walled problem. The following natural question arises: How many terms N should remain in order to keep a reliable solution? N parameter should be linked with α parameter characterizing thinness of the studied construction (L/\sqrt{F} for a beam, R/h for a shell, etc.). However, in general

$$\lim_{N \rightarrow \infty} \lim_{\alpha \rightarrow 0} (\dots) \neq \lim_{\alpha \rightarrow 0} \lim_{N \rightarrow \infty} (\dots).$$

Additional information regarding the state-of-art of the asymptotic series can be found in [23], [25], [39], [96], [97], [133], [62], [63], [244], [246].

1.2 Some Nonstandard Perturbation Procedures

1.2.1 Choice of Small Parameters

The choice of an asymptotic method and the introduction of small dimensionless parameters to an investigated system is very often the most significant and informal part of the analytical study of physical problems. This should be carried out with the help of experience and intuition, analysis of the physical nature of the problem, as well as with the use of experimental and numerical results. It is often dictated by physical considerations, which are evidently shown through dimensionless and scaling procedures. However, it seems to be sometimes advantageous to use an initial approximation guess although this is not obvious, and may perhaps seem even strange at first glance. To illustrate this, consider a simple example [42], i.e. an algebraic equation of the form

$$x^5 + x = 1. \quad (1.12)$$

We seek a real root of Equation (1.12), the exact value of which can be determined numerically: $x = 0.75487767 \dots$. A small parameter ε is not included explicitly in Equation (1.12). Consider various possibilities of introducing a parameter ε into Equation (1.12).

1. We introduce a small parameter ε as the multiplier to a nonlinear term in Equation (1.12)

$$\varepsilon x^5 + x = 1, \quad (1.13)$$

and present x as a series of ε , i.e.

$$x = a_0 + a_1 \varepsilon + a_2 \varepsilon^2 + \dots \quad (1.14)$$

Substituting series (1.14) into Equation (1.13), and equating terms of equal powers, we obtain

$$a_0 = 1, \quad a_1 = -1, \quad a_2 = 5, \quad a_3 = -35, \quad a_4 = 285, \quad a_5 = -2530, \quad a_6 = 23751.$$

These values can be predicted by a closed expression for the coefficients a_n :

$$a_n = \frac{(-1)^n (5n)!}{n!(4n+1)!}.$$

The radius R of convergence of series (1.14) is $R = \frac{4^4}{5^5} = 0.08192$. Consequently, for $\varepsilon = 1$ series (1.14) diverges very fast, so the sum of the first six terms is 21476. The situation can be corrected by the method of PA. Constructing a PA (see Chapter 1.4) with three terms in the numerator and denominator and calculating it with $\varepsilon = 1$, we obtain the value of the root $x = 0.76369$ (the error in comparison to the exact value is 1.2%).

2. We now introduce a small parameter ε as multiplier to the linear term in Equation (1.12)

$$x^5 + \varepsilon x = 1. \quad (1.15)$$

Presenting the solution of Equation (1.15) in the form

$$x(\varepsilon) = b_0 + b_1\varepsilon + b_2\varepsilon^2 + \dots, \quad (1.16)$$

and after applying the standard procedure of perturbation method, we get

$$b_0 = 1, \quad b_1 = -1, \quad b_2 = -1\frac{1}{25}, \quad b_3 = -1\frac{1}{125}, \quad b_4 = 0,$$

$$b_5 = \frac{21}{15625}, \quad b_6 = \frac{78}{78125}.$$

In this case we can also construct a general expression for the coefficients

$$b_n = -\frac{\Gamma[(4n-1)/5]}{5\Gamma[(4-n)/5]n!},$$

and determine the radius of convergence of the series (1.15): $R = \frac{5}{4^{(4/5)}} = 1.64938 \dots$. The value of $x(1)$, taking into account the first six terms of the series (1.16), deviates from the exact by 0.07%.

3. Now, let us introduce a “small parameter” δ in the exponent

$$x^{1+\delta} + x = 1, \quad (1.17)$$

and let us present x in the form

$$x = c_0 + c_1\delta + c_2\delta^2 + \dots \quad (1.18)$$

In addition, we use the expansion:

$$x^{1+\delta} = x(1 + \delta \ln |x| + \dots).$$

Coefficients of series (1.18) are determined easily, i.e. they read:

$$c_0 = 0.5, \quad c_1 = 0.25 \ln 2, \quad c_2 = -0.125 \ln 2, \quad \dots$$

The radius of convergence is equal to 1 in this case. Using PA with three terms in the numerator and denominator, if $\varepsilon = 1$, we find $x = 0.75448$, which only deviates from the exact result by 0.05%. Calculating c_i for $i = 0, 1, \dots, 12$ and constructing PA with six terms

in the numerator and denominator, we find $x = 0.75487654$ (0.00015% error). The method is called “the method of small delta” (see Section 1.2.3) [42], [43].

4. We now assume the exponent to be a large parameter. Consider the equation

$$x^n + x = 1. \quad (1.19)$$

Assuming $n \rightarrow \infty$ (the method of large δ , see Section 1.2.4), we present the desired solution in the form

$$x = \left[\frac{1}{n} (1 + x_1 + x_2 + \dots) \right]^{1/n}, \quad (1.20)$$

where $1 > x_1 > x_2 > \dots$.

Substituting the Ansatz (1.20) in Equation (1.19), and taking into account that

$$n^{1/n} = 1 + \frac{1}{n} \ln n + \dots, \quad x^{1/n} = 1 + \frac{1}{n} \ln(1 + x_1 + x_2 + \dots) + \dots,$$

one obtains the following hierarchy with increasing accuracy

$$x \approx \left(\frac{\ln n}{n} \right)^{1/n}, \quad (1.21)$$

$$x \approx \left(\frac{\ln n - \ln \ln n}{n} \right)^{1/n}, \quad (1.22)$$

...

For $n = 2$ formula (1.21) gives $x = 0.58871$; the error compared to the exact solution ($0.5(\sqrt{5} - 1) \approx 0.618034$) is 4.7%. When $n = 5$ from (1.21) we obtain $x = 0.79715$ (from numerical solution one obtains $x = 0.75488$; error of (1.21) 5.6%). Equation (1.22) for $n = 5$ gives $x = 0.74318$ (error 1.5%). Thus, even the first terms of the large δ asymptotics give excellent results.

Hence, in this case the method of large delta already provides good accuracy even for low orders of the perturbation method. Approximations (1.21), (1.22) illustrate an example of nonpower type asymptotics.

In particular, thanks to A.V. Pichugin, the obtained solution can be improved using the Lambert functions $W(z)$, which is governed by the following equation [87]

$$z = W(z)e^{W(z)}.$$

Then, the solution to our problem has the form

$$x \approx \left[\frac{1+C}{n} W \left(\frac{n}{1+C} \right) \right]^{1/n}, \quad \text{where } C = \frac{1}{2n} \ln \left(\frac{W(n)}{n} \right).$$

Note that for $n = 5$ the above formula yields $x = 0.75443$ (error 0.06%).

1.2.2 Homotopy Perturbation Method

In recent years the so-called homotopy perturbation method (HPM) has received much attention [1], [43], [130], [44], [132], [157], [158] (the term “method of artificial small parameters” is also used). Its essence is as follows. In the equations or BCs the parameter ε is introduced so that for $\varepsilon = 0$ one obtains a BVP which admits a simple solution, and for $\varepsilon = 1$

one obtains the governing BVP. Then the perturbation method regarding ε is applied and we put $\varepsilon = 1$ in the final formula. Apparently, this approach is not new and has already been used in references [115], [159] and [207]. However, the above term, emphasizing the continuous transition from the initial value $\varepsilon = 0$ to the value of $\varepsilon = 1$ (homotopy deformation), seems to be most adequate. Let us analyze an example of the homotopy perturbation parameter method using an approach taken from reference [8], [9]. The occurrence of internal resonance between modes belongs to a special feature of nonlinear systems with distributed parameters. This is why in many cases the neglect of higher modes can lead to significant errors. The following approach describes the asymptotic method of solving problems of nonlinear vibrations of systems with distributed parameters, allowing us to broadly take into account all modes. The vibrations of a square membrane lying on a nonlinear elastic foundation can be governed by the following PDE:

$$\frac{\partial^2 w}{\partial x^2} + \frac{\partial^2 w}{\partial y^2} - \frac{\partial^2 w}{\partial t^2} - cw - \varepsilon w^3 = 0, \quad (1.23)$$

where ε is the dimensionless small parameter ($\varepsilon \ll 1$).

The BCs are as follows

$$w|_{x=0,L} = w|_{y=0,L} = 0. \quad (1.24)$$

The desired periodic solution must satisfy the periodicity conditions of the form

$$w(t) = w(t + T), \quad (1.25)$$

where $T = \frac{2\pi}{\omega}$ is the period, and Ω is the natural frequency of vibrations. We seek the natural frequencies corresponding to these forms of natural vibration frequencies at which the linear case ($\varepsilon = 0$) is realized by one half-wave in each direction x and y . We introduce the transformation of time

$$\tau = \omega t. \quad (1.26)$$

The solution is sought in the form of power series

$$w = w_0 + \varepsilon w_1 + \varepsilon^2 w_2 + \dots, \quad (1.27)$$

$$\omega = \omega_0 + \varepsilon \omega_1 + \varepsilon^2 \omega_2 + \dots \quad (1.28)$$

Substituting Ansatzes (1.27), (1.28) to Equations (1.23)–(1.25), and equating terms of equal powers, we obtain the following recurrent sequence of linear BVPs:

$$\frac{\partial^2 w_0}{\partial x^2} + \frac{\partial^2 w_0}{\partial y^2} - \omega_0^2 \frac{\partial^2 w_0}{\partial \tau^2} - cw_0 = 0, \quad (1.29)$$

$$\frac{\partial^2 w_1}{\partial x^2} + \frac{\partial^2 w_1}{\partial y^2} - \omega_1^2 \frac{\partial^2 w_1}{\partial \tau^2} - cw_1 = 2\omega_0 \omega_1 \frac{\partial^2 w_0}{\partial \tau^2} + w_0^3, \quad (1.30)$$

...

The BCs (1.24) and periodicity conditions (1.25) take the following form for $i = 1, 2, \dots$:

$$w_i|_{x=0,L} = w_i|_{y=0,L} = 0, \quad (1.31)$$

$$w_i(\tau) = w_i(\tau + 2\pi). \quad (1.32)$$

The solution to Equation (1.29) is as follows:

$$w_{0,0} = \sum_{m=1}^{\infty} \sum_{n=1}^{\infty} A_{m,n} \sin\left(\frac{\omega_{m,n}}{\omega_0} \tau\right) \sin\left(\frac{\pi m}{L} x\right) \sin\left(\frac{\pi n}{L} y\right), \quad (1.33)$$

where $\omega_{m,n} = \sqrt{\pi^2 \frac{(m^2+n^2)}{L} + c}$, $m, n = 1, 2, 3, \dots$, and $A_{1,1}$ is the amplitude of the fundamental tone of vibrations; $A_{m,n}$, $m, n = 1, 2, 3, \dots$, $(m, n) \neq (1, 1)$ is the amplitude of the subsequent modes; $\omega_{m,n}$ are the natural frequencies of the counterpart linear system, $\omega_0 = \omega_{1,1}$.

Next approximation results in solving the BVP (1.30)–(1.32). To prevent the appearance of secular terms in the right hand side of Equation (1.30), the coefficients standing by the terms of the form

$$\sin\left(\frac{\omega_{m,n}}{\omega_0} \tau\right) \sin\left(\frac{\pi m}{L} x\right) \sin\left(\frac{\pi n}{L} y\right), \quad m, n = 1, 2, 3, \dots$$

should be compared with zero.

These conditions lead to the following infinite system of nonlinear algebraic equations:

$$\frac{2A_{m,n}\omega_1}{\beta_2\omega_0} (\omega_{m,n})^2 = \sum_{i=1}^{\infty} \sum_{j=1}^{\infty} \sum_{k=1}^{\infty} \sum_{l=1}^{\infty} \sum_{p=1}^{\infty} \sum_{s=1}^{\infty} C_{m,n}^{(ijklps)} A_{i,j} A_{k,l} A_{p,s}, \quad (1.34)$$

where $m, n = 1, 2, 3, \dots$

Coefficients are found by substituting Ansatz (1.33) into the right hand side of Equation (1.30) and carrying out the relevant simplifications. System (1.34) can be solved by reduction. However, a sufficiently large number of equations produces significant computational difficulties. In addition, this approach does not take into account the influence of higher modes of vibrations. Therefore, in order to omit the above-mentioned difficulties we use further the HPM.

On the right side of each (m, n) -th equation of system (1.34) we introduce the parameter μ associated with those members of $A_{i,j} A_{k,l} A_{p,s}$, for which the following condition is valid: $(i > m) \cup (k > m) \cup (p > m) \cup (j > n) \cup (l > n) \cup (s > n)$. Thus, for $\mu = 0$ system (1.34) takes the “triangular” form, and for $\mu = 1$ it returns to its original form. Next, we seek a solution in the form of the following series:

$$\omega_1 = \omega^{(0)} + \mu\omega^{(1)} + \mu^2\omega^{(2)} + \dots, \quad (1.35)$$

$$A_{m,n} = A_{m,n}^{(0)} + \mu A_{m,n}^{(1)} + \mu^2 A_{m,n}^{(2)} + \dots, \quad (1.36)$$

where $m, n = 1, 2, 3, \dots$, $(m, n) \neq (1, 1)$.

In the so-far obtained solution we put $\mu = 1$.

This approach allows us to keep any number of equations in system (1.34). Below we limit ourselves to the first two terms in expansions (1.35), (1.36). We analyze the solutions and note that in this problem the parameter c plays the role of a bifurcation parameter. In general, for $c \neq 0$, $c \sim 1$, the system (1.34) admits the following solution:

$$A_{i,j}, \quad i, j = 1, 2, 3, \dots, \quad (i, j) \neq (m, n),$$

$$\omega_1 = \frac{27}{128} \frac{A_{m,n}^2 \omega_0}{\omega_{m,n}^2}, \quad m, n = 1, 2, 3, \dots$$

Amplitude-frequency response is given by the following formula

$$\Omega_{m,n} = \omega_{m,n} + 0.2109375 \frac{A_{m,n}^2}{\omega_{m,n}} \varepsilon + \dots$$

It is of particular interest to the case when the linear component of the restoring force is zero ($c = 0$), and the phenomenon of internal resonance between modes of vibrations occurs. Solving system (1.34) by the method described so far we find

$$A_{m,n} = 0, \quad m, n = 1, 2, 3, \dots, \quad (m, n) \neq (1, 1), \quad (m, n) \neq (2i - 1, 2i - 1), \quad i = 1, 2, 3, \dots, \\ A_{3,3} = -4.5662 \cdot 10^{-3} A_{1,1}, \quad A_{5,5} = 2.1139 \cdot 10^{-5} A_{1,1}, \dots, \quad \omega_1 = 0.211048 A_{1,1}^2 / \omega_0.$$

If vibrations are excited by the mode (1, 1) all odd modes (3, 3), (5, 5) etc. are also realized. However, if the vibrations are excited by one of the higher modes, the result of energy redistribution of modes appear at lower orders until the fundamental mode (1, 1).

1.2.3 Method of Small Delta

In references [42], [43] the effective method of small δ has been proposed, which we are going to explain through a few examples. Let us construct a periodic solution to the following Cauchy problem

$$x_{tt} + x^3 = 0, \tag{1.37}$$

$$x(0) = 1, \quad x_t(0) = 0. \tag{1.38}$$

We introduce a homotopy parameter δ in Equation (1.37), and hence

$$x_{tt} + x^{1+2\delta} = 0. \tag{1.39}$$

At the final expression one should put $\delta = 1$, but in the process of solving we assume $\delta \ll 1$. Then

$$x^{2\delta} = 1 + \delta \ln x^2 + 0.5\delta^2 (\ln x^2)^2 + \dots \tag{1.40}$$

We assume a solution to Equation (1.37) in the form

$$x = \sum_{k=0}^{\infty} \delta^k x_k, \tag{1.41}$$

and carry out the change of independent variable

$$t = \frac{\tau}{\omega}, \tag{1.42}$$

where $\omega^2 = 1 + \alpha_1 \delta + \alpha_2 \delta^2 + \dots$

The constants α_i ($i = 1, 2, \dots$) are determined during solution process. After substituting Ansatzes (1.40)–(1.42) in Equation (1.39), and splitting with respect to δ , the following recurrent sequence of Cauchy problems is obtained

$$x_{0\tau\tau} + x_0 = 0, \tag{1.43}$$

$$x_0(0) = 1, \quad x_{0\tau}(0) = 0; \tag{1.44}$$

$$x_{1\tau\tau} + x_1 = -x_0 \ln(x_0^2) - \alpha_1 x_{0\tau\tau}, \quad (1.45)$$

$$x_1(0) = x_{1\tau} = 0; \quad (1.46)$$

$$x_{2\tau\tau} + x_2 = -x_1 \ln(x_1^2) - 2x_1 - x_0(\ln(x_0^2))^2 - \alpha_2 x_{0\tau\tau} - \alpha_1 x_{1\tau\tau}; \quad (1.47)$$

$$x_1(0) = x_{1\tau} = 0; \quad (1.48)$$

....

A Cauchy problem regarding zero order approximation (1.43), (1.44) has the following solution.

$$x_0 = \cos \tau.$$

In the first approximation, one obtains

$$x_{1\tau\tau} + x_1 = -\cos \tau \ln(\cos^2 \tau) + \alpha_1 \cos \tau \equiv L_0.$$

The condition of absence of secular terms in the solution of this equation can be written as follows

$$\int_0^{\pi/2} L_0 \cos t \, dt = 0,$$

and it allows us to determine the constant $\alpha_1 = 1 - 2 \ln 2$.

The period of vibration can be written as

$$T = 2\pi[1 + \delta(\ln 2 - 0.5)].$$

For $\delta = 1$, we have $T = 6.8070$, while the exact value is $T = 7.4164$ (the error introduced by the approximate solution is 8.2%). A solution to the Cauchy problem of the next approximation (1.47), (1.48) gives the period value practically coinciding with the exact one ($T = 7.4111$).

We now consider the wave equation

$$u_{tt} = u_{xx}, \quad (1.49)$$

with nonlinear BCs of the form

$$u(0, t) = 0, \quad (1.50)$$

$$u_x(1, t) + u(1, t) + u^3(1, t) = 0. \quad (1.51)$$

We introduce the parameter δ into Equation (1.51) as follows

$$u_x(1, t) + u(1, t) + u^{1+2\delta}(1, t) = 0. \quad (1.52)$$

In the final expression we put $\delta = 1$, but in the asymptotical process we assume $\delta \ll 1$. We have

$$u^3 \equiv u^{1+2\delta} = u \left[1 + \delta \ln u^2 + \frac{\delta^2}{2} (\ln u^2)^2 + \dots \right]. \quad (1.53)$$

We assume the solution to Equation (1.49) to be in the form

$$u = \sum_{k=0}^{\infty} \delta^k u_k. \quad (1.54)$$

After substituting Ansatzes (1.54), (1.52) into Equations (1.49), (1.50), (1.52), and after splitting regarding the parameter δ , we obtain the following recurrent sequence of BVPs:

$$u_{0\tau\tau} = u_{0xx}; \quad (1.55)$$

$$\text{at } x = 0, \quad u_0 = 0; \quad (1.56)$$

$$\text{at } x = 1, \quad u_{0x} + 2u_0 = 0; \quad (1.57)$$

$$u_{0\tau\tau} = u_{0xx} - \sum_{p=0}^1 \alpha_{i-p} u_{p\tau\tau}; \quad (1.58)$$

$$\text{at } x = 0, \quad u_1 = 0; \quad (1.59)$$

$$\text{at } x = 1, \quad u_{1x} + 2u_1 = -u_0 \ln u_0^2; \quad (1.60)$$

$$u_{0\tau\tau} = u_{0xx} - \sum_{p=0}^2 \alpha_{i-p} u_{p\tau\tau}; \quad (1.61)$$

$$\text{at } x = 0, \quad u_2 = 0; \quad (1.62)$$

$$\text{at } x = 1, \quad u_{2x} + 2u_2 = -u_1 \ln u_0^2 - 2u_1 - 0.5u_0 (\ln u_0^2)^2; \quad (1.63)$$

...

where $\alpha_0 = 0$.

The solution of the BVP of the zero order approximation (1.55)–(1.57) can be written as

$$u_0 = A \sin(\omega_0 x) \sin(\omega_0 \tau), \quad (1.64)$$

where the frequency ω_0 is determined from the transcendental equation

$$\omega_0 = 2 \tan \omega_0. \quad (1.65)$$

The first few nonzero values of ω are given in Table 1.2.

When $k \rightarrow \infty$, we have the asymptotics: $\omega^{(k)} \rightarrow 0.5\pi(2k + 1)$.

Table 1.2 First few roots of transcendental equation (1.65)

$\omega_0^{(1)}$	$\omega_0^{(2)}$	$\omega_0^{(3)}$	$\omega_0^{(4)}$	$\omega_0^{(5)}$	$\omega_0^{(6)}$	$\omega_0^{(7)}$	$\omega_0^{(8)}$	$\omega_0^{(9)}$	$\omega_0^{(10)}$
2.289	5.087	8.096	11.173	14.276	17.393	20.518	23.646	26.778	29.912

BVP problem of the first approximation is as follows:

$$u_{1xx} - u_{1\tau\tau} = \alpha_1 A \omega_0^2 \sin(\omega_0 x) \sin(\omega_0 \tau), \quad (1.66)$$

$$\text{at } x = 0, \quad u_1 = 0, \quad (1.67)$$

$$\text{at } x = 1, \quad u_{1x} + 2u_1 = A_1 \sin(\omega_0 \tau) [\ln(A^2 \sin^2 \omega_0) + \ln \sin^2(\omega_0 \tau)], \quad (1.68)$$

where $A_1 = -A \sin \omega_0$.

The particular solution to Equation (1.66) satisfying the BC (1.67) has the form

$$u_1^{(1)} = -0.5 \alpha_1 A \omega_0 x \cos(\omega_0 x) \sin(\omega_0 \tau). \quad (1.69)$$

We choose the constant α_1 in such a way that it compensates the secular term on the r.h.s. of Equation (1.68)

$$\alpha_1 = \frac{2R_1}{\omega_0(6 + \omega_0^2)},$$

where $R_1 = \ln(0.25eA^2 \sin^2 \omega_0)$.

Nonsecular harmonics on the r. h. s. of Equation (1.68) yield the solution

$$u_1^{(2)} = 4A_1 \sum_{k=2}^{\infty} T_k \sin(\omega_0 kx) \sin(\omega_0 k\tau) \frac{1}{k^2 - 1}, \quad (1.70)$$

where $T_k = 1/[k\omega_0 \cos(k\omega_0) + 2 \sin(k\omega_0)]$.

The complete solution of the first approximation has the form

$$u_1 = u_1^{(1)} + u_1^{(2)}.$$

Assuming $\delta = 1$, we obtain the solution of Equations (1.49)–(1.51).

Let us now consider the Schrödinger equation

$$\Psi_{xx} - x^{2N} \Psi + E \Psi = 0, \quad (1.71)$$

$$\Psi(\pm\infty) = 0. \quad (1.72)$$

Here Ψ is the wave function; E is the energy and plays the role of an eigenvalue.

It is shown that the eigenvalue problem (1.71)–(1.72) has a discrete countable spectrum E_n , $n = 0, 1, 2, \dots$ [228]. For $N = 2$ the eigenvalue problem (1.71), (1.72) has an exact solution. Now let N differ slightly from 2, i.e.

$$\Psi_{xx} - x^{2+2\delta} \Psi + E \Psi = 0. \quad (1.73)$$

We assume the expansion

$$x^{2\delta} = 1 + \delta \ln(x^2) + \dots,$$

and we will search for the eigenfunction Ψ and the eigenvalue E in the form of the following series

$$\Psi = \Psi_0 + \delta \Psi + \delta^2 \Psi^2 + \dots, \quad (1.74)$$

$$E = E_0 + \delta E + \delta^2 E^2 + \dots \quad (1.75)$$

As a result, after the asymptotic splitting, we obtain the following hierarchy of recursive sequence of eigenvalue problems

$$\Psi_{0xx} - x^2 \Psi_0 + E_0 \Psi_0 = 0, \quad (1.76)$$

$$\Psi_{1xx} - x^2 \Psi_1 + E_0 \Psi_1 + E_1 \Psi_0 = x^2 \Psi_0 \ln(x^2), \quad (1.77)$$

...

$$|\Psi_i| \rightarrow 0 \quad \text{at} \quad |x| \rightarrow \infty, \quad i = 1, 2, 3, \dots \quad (1.78)$$

The solution to the eigenvalue problem (1.76), (1.78) has the form

$$E_0^{(n)} = 2n + 1, \quad \Psi_0^{(n)} = e^{-x^2/2} H_n(x), \quad n = 1, 2, 3, \dots,$$

where $H_n(x)$ is the Struve function ([2], Chapter 12).

From the eigenvalue problem (1.77), (1.78) we find

$$E_1^{(n)} = \frac{\int_{-\infty}^{\infty} x^2 e^{-x^2} H_n^2(x) \ln(x^2) dx}{\sqrt{\pi} 2^n n!}.$$

For $n = 0$ one obtains $H_0(x) = 1$, and

$$\int_{-\infty}^{\infty} x^2 \ln x e^{-x^2} dx = \frac{\sqrt{\pi}}{8} (2 - 2 \ln 2 - C),$$

where $C = 0.577215 \dots$ is the Euler constant. Hence

$$E_0^{(0)} = 1 + \frac{1}{16} (2 - 2 \ln 2 - C) \delta + \dots \quad (1.79)$$

1.2.4 Method of Large Delta

An alternative method of small delta is the method of large delta, which we demonstrate using as an example the following nonlinear equation

$$x_n + x^n = 0, \quad n = 3, 5, 7, \dots \quad (1.80)$$

This equation can be integrated with the functions Cs and Sn , introduced by Liapunov in [159] (inversions of incomplete beta functions, see also [219]). Note that much later the same (up to normalization) function have been proposed by Rosenberg, who called them Ateb-functions [213], [214]. However, working with these objects is inconvenient, and therefore the problem arises of finding the approximate analytical solution to Equation (1.80) in expressed through elementary functions. We construct asymptotics of periodic solutions of Equation (1.80) at $n \rightarrow \infty$. Let the initial conditions for Equation (1.80) be

$$x(0) = 0, \quad \dot{x}(0) = 1. \quad (1.81)$$

The first integral of the Cauchy problem (1.80), (1.81) can be written as follows

$$\left(\frac{dx}{dt}\right)^2 = 1 - \frac{2x^{n+1}}{n+1}. \quad (1.82)$$

The replacement of $x = \lambda^{-\lambda/2}$, $\lambda = 2/(n+1)$, and integration gives us a solution in the following implicit form

$$\lambda^{\lambda/2}t = \int_0^{0 \leq \xi \leq 1} \frac{d\xi}{\sqrt{1 - \xi^{2/\lambda}}}.$$

After replacing $\xi = \sin^\lambda \theta$ this implicit solution is transformed into an expression that contains a small parameter in the exponent of the integrand, namely we have

$$\lambda^{\lambda/2}t = \lambda \int_0^{0 \leq \theta \leq \pi/2} \sin^{-1+\lambda} \theta d\theta.$$

We now consider the integrand separately:

$$\sin^{-1+\lambda} \theta = \theta^{-1+\lambda} \left(\frac{\theta}{\sin \theta}\right) = \theta^{-1+\lambda} \left[\frac{\theta}{\sin \theta} - \lambda \ln \frac{\theta}{\sin \theta} + \dots\right].$$

Expanding this function into a Maclaurin series, one obtains

$$\sin^{-1+\lambda} \theta = \theta^{-1+\lambda} + \frac{\theta^{-1+\lambda}}{3} + \dots + O(\lambda).$$

The first term of this expression makes the main contribution, so in the first approximation we can suppose

$$\lambda^{\lambda/2}t \approx \theta^\lambda, \quad \text{i.e.} \quad \theta \approx \lambda^{1/2}t^{1/\lambda}.$$

In the original variables one obtains

$$x \approx \lambda^{-\lambda/2} \sin^\lambda (\lambda^{1/2}t^{1/\lambda}). \quad (1.83)$$

The solution (1.83) should be used on a quarter-period, which yields

$$T = 4 \left(\frac{\pi}{2\lambda^{1/2}}\right)^\lambda. \quad (1.84)$$

Let us analyze the solution (1.83), (1.84). At $n = 1$ one obtains the exact values $x = \sin t$, $T = 2\pi$, whereas for $n \rightarrow \infty$ one obtains $T \rightarrow 4$. Expanding the r.h.s. of Equation (1.83) into a series of t , and restricting our considerations to the first term only, we obtain a nonsmooth solution [67]. We estimate the error of the solution (1.84). For this purpose we use the expression

$$\lambda \int_0^{\pi/2} \sin^{-1+\lambda} \theta d\theta = 0.5 \lambda B(0.5\lambda, 0.5) \equiv A_1, \quad (1.85)$$

where $B(\dots, \dots)$ is the beta function ([2], Chapter 6).

Table 1.3 Comparison of exact and approximate solutions

n	1	3	5	...	∞
A_1	π^2	1.30	1.20	...	1
A_2	π^2	1.25	1.16	...	1
$\Delta, \%$	0	5	3	...	~ 0

The approximate value of the integral on the l.h.s. of Equation (1.83) is calculated as follows: $A_2 = (\pi/2)^\lambda$. Numerical comparison of the values A_1, A_2 and error estimation Δ is given in Table 1.3.

Thus, the first approximation of the asymptotics for $n \rightarrow \infty$ already gives quite acceptable accuracy for practical purposes, even for not very large values of n . Note that expression (1.83) gives an approximation of incomplete beta function ([2], Chapter 6) from $n = 1$ (sinus function) to $n = \infty$ (linear function).

1.2.5 Application of Distributions

Asymptotic methods are based, generally speaking, on the use of Taylor series. In this connection the question arises: what to do with functions of the form $\exp(-\varepsilon^{-1}x)$, which cannot be expanded into a Taylor series for $\varepsilon \rightarrow 0$ via smooth functions [202]. The way out lies in the transition to the following distribution [100]:

$$H(x) \exp(-\varepsilon^{-1}x) = \sum_{n=0}^{\infty} (-1)^n \varepsilon^{n+1} \delta^{(n)}(x), \quad (1.86)$$

where $\delta(x)$ is the Dirac delta function, representing the derivative of the Heaviside function $H(x)$; $\delta^{(n)}(x)$, $n = 1, 2, \dots$ are the derivatives of the delta function.

We show how formally the formula (1.86) can be obtained. Applying the Laplace transform to function $\exp(-\varepsilon^{-1}x)$, one obtains:

$$\int_0^{\infty} \exp(-\varepsilon^{-1}x) dx = \frac{\varepsilon}{\varepsilon p + 1}.$$

Expanding the r.h.s. of this equation into a Maclaurin series of ε , and then calculating inverse transform term by term, one obtains expansion (1.86). Thus, we again use the Taylor series, but now in the dual space.

Here is another interesting feature of the approach using distributions: a singular perturbed problem can be regarded as a regular perturbed one [100]. Suppose, for example, we deal with the ODE:

$$\varepsilon y' + y = 0 \quad x > 0, \quad y = 1 \quad \text{at} \quad x = 0.$$

This is a singularly perturbed problem: for $\varepsilon = 0$ one obtains a smooth solution $y = 0$, which does not satisfy the given initial condition. However, one can seek a solution in the form of a nonsmooth function. Namely, assuming $z(x) = H(x)y(x)$, one obtains

$$\varepsilon z' = -z + \varepsilon \delta(x). \quad (1.87)$$

A solution of Equation (1.87) is sought in the following series form

$$z = \sum_{n=0}^{\infty} z_n \varepsilon^n.$$

As a result one obtains

$$z_0 = 0, \quad z_1 = \delta(x), \quad z_{n+1} = (-1)^n \delta^{(n)}, \quad n = 1, 2, \dots \quad (1.88)$$

Note that expressions (1.88) allow us to reach smooth functions. To do this, it is possible to apply the Laplace transform, then the PA in the dual space, and then one may calculate inverse Laplace transforms.

We show other application of the asymptotic method using distribution [21]. Consider the equation of the membrane, reinforced with fibers of small but finite width ε . The governing PDE is

$$[1 + 2\varepsilon\Phi_0(y)]u_{xx} + u_{yy} = 0, \quad (1.89)$$

where

$$\Phi_0(y) = \sum_{k=-\infty}^{\infty} [H(y + kb - \varepsilon) + H(y - kb + \varepsilon)].$$

Let us expand the function $\Phi_0(y)$ in a series of ε . Applying the two-sided Laplace transform [241], one obtains

$$\bar{\Phi}(p, \varepsilon) = \int_{-\infty}^{\infty} e^{-p|y|} \Phi(y, \varepsilon) dy.$$

Expanding the function $\bar{\Phi}(p, \varepsilon)$ in a series of ε , and performing the inverse Laplace transform, we obtain

$$\Phi_0(y) = 2\varepsilon\Phi(y) + 2\varepsilon \sum_{k=1,3,5,\dots} \varepsilon^k \Phi^{(k)}(y), \quad (1.90)$$

where $\Phi(y) = \sum_{k=-\infty}^{\infty} \delta(y - kb)$.

Now, let us consider a solution to Equation (1.89) in the form

$$u = u_0 + \varepsilon u_1 + \varepsilon^2 u_2 + \dots \quad (1.91)$$

Substituting Ansatzes (1.90), (1.91) into Equation (1.89), and splitting the resulting equation with respect to ε , we arrive at the recursive sequence of BVPs:

$$[1 + 2\varepsilon\Phi(y)]u_{0xx} + u_{0yy} = 0, \quad (1.92)$$

$$[1 + 2\varepsilon\Phi(y)]u_{1xx} + u_{1yy} = -\varepsilon u_{0xx} \Phi_y(y), \quad (1.93)$$

...

Thus, in the zero approximation, we obtain the problem with one-dimensional fibers (1.92), and the influence of the width of fibers is taken into account in the first approximation (1.93).

1.3 Summation of Asymptotic Series

1.3.1 Analysis of Power Series

Here we follow [133], [242], [243], [245].

We assume that one obtains the following series as the result of an asymptotic study:

$$f(\varepsilon) \sim \sum_{n=0}^{\infty} C_n \varepsilon^n \quad \text{for } \varepsilon \rightarrow 0. \quad (1.94)$$

As it is known, the radius of convergence ε_0 of series (1.94) is determined by the distance to the nearest singularity of the function $f(\varepsilon)$ on the complex plane, and can be found using the following Cauchy-Hadamard formula:

$$\frac{1}{\varepsilon_0} = \overline{\lim}_{n \rightarrow \infty} |C_n|^{1/n}.$$

If the nearest singularity lies on the positive real axis, then the coefficients C_n usually have one and the same algebraic sign, for example

$$\frac{1}{1 - \varepsilon} \sim 1 + \varepsilon + \varepsilon^2 + \varepsilon^3 + \dots$$

If the nearest singularity is located on the negative axis, the algebraic signs of the coefficients C_n are usually alternated, for example

$$\frac{1}{1 + \varepsilon} \sim 1 - \varepsilon + \varepsilon^2 - \varepsilon^3 + \dots$$

The pattern of signs is usually set pretty quickly. If there are several features of the same radius, which could happen to a real function with complex singularities necessarily occurring in complex conjugate pairs, then the rule of alternation of signs may be more complex, such as

$$\frac{1 + \varepsilon}{1 + \varepsilon^2} \sim 1 + \varepsilon - \varepsilon^2 - \varepsilon^3 + \varepsilon^4 + \varepsilon^5 - \varepsilon^6 - \varepsilon^7 \dots$$

Here we have a pattern of signs $++--$. To define ε_0 it may be useful to apply the so-called Domb-Sykes plot [133], [242], [243], [245]. Let the function f have one of the nearest singularities at a point $\varepsilon = \pm\varepsilon_0$ with an index of α , i.e.

$$f(\varepsilon) \sim \begin{cases} (\varepsilon_0 \pm \varepsilon)^\alpha & \text{for } \alpha \neq 0, 1, 2, \dots, \\ (\varepsilon_0 \pm \varepsilon)^\alpha \ln(\varepsilon_0 \pm \varepsilon) & \text{for } \alpha = 0, 1, 2, \dots, \end{cases}$$

then we get

$$\frac{C_n}{C_{n-1}} \sim \pm \frac{1}{\varepsilon_0} \left(1 - \frac{1 + \alpha}{n}\right) n.$$

Constructing a graph of C_n/C_{n-1} on the vertical axis and $1/n$ on the horizontal axis, one obtains the radius of convergence (as the reciprocal of the intercepts on the axis C_n/C_{n-1}), and then, knowing the slope, the required singularity. Figure 1.2 shows the numerical results

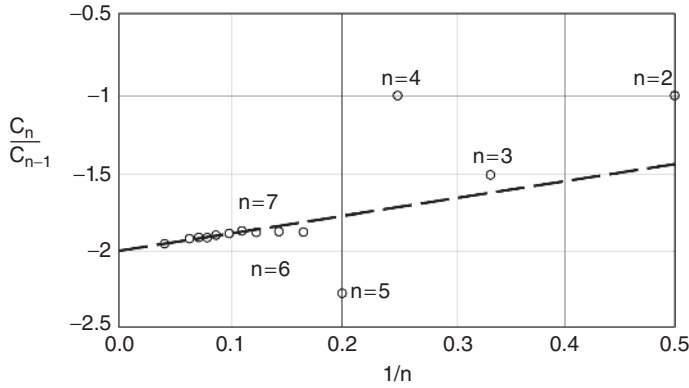

Figure 1.2 The Domb-Sykes plot for $f(\epsilon) = \epsilon(1 + \epsilon)(1 + 2\epsilon)^{-1/2}$

for the function

$$f(\epsilon) = \epsilon(1 + \epsilon)(1 + 2\epsilon)^{-1/2} \sim \epsilon - \epsilon^2 + \frac{3}{2}\epsilon^3 - \frac{3}{2}\epsilon^4 + \frac{27}{8}\epsilon^5 - \frac{51}{8}\epsilon^6 + \frac{191}{16}\epsilon^7 - \frac{359}{16}\epsilon^8 + \dots, \quad (1.95)$$

starting with $n = 7$ points arranged in a linear relationship.

If ϵ_0 or α are known from physical considerations, they can be used for the construction of the Domb-Sykes plot. If several singularities have the same convergence radius, so that the signs of the coefficients oscillate, one way is to try to construct a dependence on the value $(C_n/C_{n-1})^{1/2}$. If the radius of convergence tends to infinity and $C_n/C_{n-1} \sim k/n$, then the analyzed function has a factor $\exp(k\epsilon)$, where $C_n/C_{n-1} \sim k/n^{1/p}$ has a factor $\exp(\epsilon^p)$. If the radius of convergence tends to zero, then the analyzed function has an essential singularity and asymptotic expansion diverges. If the coefficients behave like $C_{n-1}/C_n \sim 1/(kn)$, then we can write $C_n \sim Ck^n n!$, where C is a constant.

Knowledge of singular solutions can eliminate them from the perturbation series and thus its convergence can be significantly improved. We describe some techniques for removing singularities. If the singularity lies on the positive real axis, then it often means that the function $f(\epsilon)$ is multivalued, and that there is a maximum attainable point $\epsilon = \epsilon_0$. Then, the inverse of the original function $\epsilon = \epsilon(f)$ can be single valued. For example, consider the function

$$f(\epsilon) = \arcsin \epsilon = \epsilon + \frac{1}{6}\epsilon^3 + \frac{3}{40}\epsilon^5 + \frac{5}{112}\epsilon^7 + \dots, \quad (1.96)$$

and the inverse of this function is

$$\epsilon \sim f - \frac{1}{6}f^3 + \frac{1}{1}20f^5 - \frac{1}{5040}f^7 + \dots \quad (1.97)$$

Numerical results are shown in Figure 1.3, where the solid curve denotes the function $\arcsin \epsilon$, the dotted and dashed curve shows the n -term expansions (1.96) and k -terms expansions (1.97) for different numbers of terms. It is evident that the expansion (1.97) achieves a good approximation of the second branch of the original function.

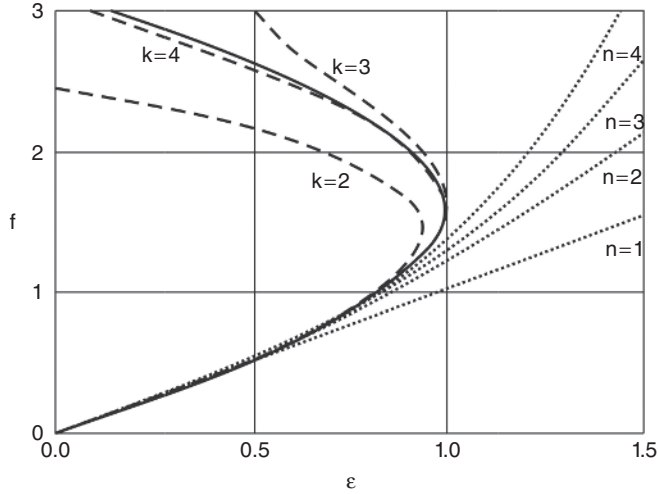

Figure 1.3 Application of the inversion method of a power series

If

$$f \sim A(\epsilon_0 - \epsilon)^\alpha \quad \text{for } \epsilon \rightarrow \epsilon_0, \quad 0 < \alpha < 1,$$

the transition to the function $f^{1/\alpha}$ removes the singularity.

Consider the following function

$$f(\epsilon) = e^{-\epsilon/2} \sqrt{1 + 2\epsilon} \sim 1 + \frac{1}{2}\epsilon - \frac{7}{8}\epsilon^2 + \frac{41}{48}\epsilon^3 - \frac{367}{384}\epsilon^4 + \frac{4849}{3840}\epsilon^5 + \dots \quad (1.98)$$

The radius of convergence of this expansion is equal to 1/2, while the radius of convergence of functions

$$f^2 \sim 1 + \epsilon - \frac{3}{2}\epsilon^2 + \frac{5}{6}\epsilon^3 - \frac{7}{24}\epsilon^4 + \frac{3}{40}\epsilon^5 + \dots \quad (1.99)$$

is infinite.

Numerical results are shown in Figure 1.4, where the solid curve denotes the function $f(\epsilon) = e^{-\epsilon/2} \sqrt{1 + 2\epsilon}$, the dotted and dashed curve show the n -term expansions (1.98) and the square roots of k -term expansions (1.99), respectively.

In addition, knowing the singularity, one can construct a new function $f_M(\epsilon)$ (multiplicative extraction rule)

$$f(\epsilon) = (\epsilon_0 - \epsilon)^\alpha f_M(\epsilon),$$

or $f_A(\epsilon)$ (additive extraction rule)

$$f(\epsilon) = A(\epsilon_0 - \epsilon)^\alpha f_A(\epsilon).$$

The functions $f_M(\epsilon)$ and $f_A(\epsilon)$ should not contain singularities at ϵ_0 . In many cases, one can effectively use the conformal transformation of the PS [145], a fairly complete catalog of which is given in [52]. In particular, it sometimes turns out to be a successful Euler transformation

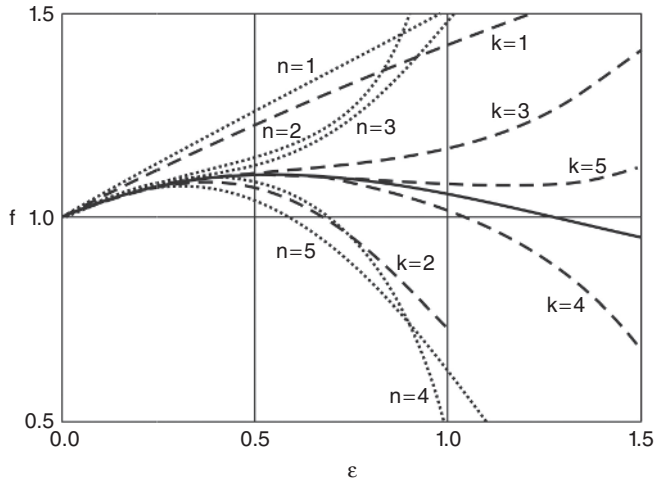

Figure 1.4 Functions, expansions and square roots (see text)

[38], [39], [242], [243], [244], [245] based on the introduction of a new variable

$$\tilde{\epsilon} = \frac{\epsilon}{1 - \epsilon/\epsilon_0}. \tag{1.100}$$

Recasting the function f in terms of $\tilde{\epsilon}$, $f \sim \sum d_n \tilde{\epsilon}^n$ has the singularity pushed out at the point $\tilde{\epsilon} = \infty$. For example, the function (1.95) is singular at the $\epsilon = -1/2$, which can be eliminated with the Euler transformation $\tilde{\epsilon} = \epsilon/(1 + 2\epsilon)$. The expansion of the function (1.95) in terms of $\tilde{\epsilon}$ is

$$f(\tilde{\epsilon}) \sim 1 + \frac{1}{2}\tilde{\epsilon} + \frac{1}{8}\tilde{\epsilon}^2 - \frac{31}{48}\tilde{\epsilon}^3 - \frac{895}{384}\tilde{\epsilon}^4 - \frac{22591}{3840}\tilde{\epsilon}^5 + \dots \tag{1.101}$$

Some numerical results are shown in Figure 1.5, where dotted and dashed curves show the n -term expansions (1.95) and k -terms in the expansion (1.101).

A natural generalization of Euler transformation is

$$\tilde{\epsilon} = \frac{\epsilon}{(1 - \epsilon/\epsilon_0)^\alpha},$$

where α is the real number.

1.3.2 Padé Approximants and Continued Fractions

The coefficients of the Taylor series in the aggregate have a lot more information about the values of features than its partial sums. It is only necessary to be able to retrieve it, and some of the ways to do this is to construct a Padé approximation [244]. Padé approximation (PA) allow us to implement among the most salient natural transformation of power series in a fractional rational function. Let us define a PA following [29], [18]. Suppose we have power series

$$f(\epsilon) = \sum_{i=1}^{\infty} c_i \epsilon^i. \tag{1.102}$$

Table 1.4 Padé table

$m \backslash n$	0	1	2	...
0	$f_{[0/0]}(\epsilon)$	$f_{[1/0]}(\epsilon)$	$f_{[2/0]}(\epsilon)$...
1	$f_{[0/1]}(\epsilon)$	$f_{[1/1]}(\epsilon)$	$f_{[2/1]}(\epsilon)$...
2	$f_{[0/2]}(\epsilon)$	$f_{[1/2]}(\epsilon)$	$f_{[2/2]}(\epsilon)$...
...

Functions $f_{[n/m]}(\epsilon)$ at different values of n and m form a set which is usually written in the form of a table, called the Padé table (Table 1.4). The terms of the first row of the Padé table correspond to the finite sums of the Maclaurin series. In case of $n = m$ one obtains the diagonal PA, the most common in practice. Note that the Padé table can have gaps for those indices n, m , for which the PA does not exist.

We note some properties of the PA (see [5], [7], [29], [18], [231] for more details).

1. If the PA at the chosen m and n exists, then it is unique.
2. If the PA sequence converges to a function, the roots of its denominator tend to the poles of the function. This allows for a sufficiently large number of terms to determine the pole, and then to perform an analytical continuation.
3. The PA has meromorphic continuation regarding a given power series functions.
4. The PA on the inverse function is treated as the PA function inverse itself. This property is called duality and more exactly formulated as follows. Let

$$q(\epsilon) = f^{-1}(\epsilon) \quad \text{and} \quad f(0) \neq 0, \quad \text{then} \quad q_{[n/m]}(\epsilon) = f_{[n/m]}^{-1}(\epsilon), \quad (1.107)$$

provided that one of these approximations exists.

5. Diagonal PA are invariant under fractional linear transformations of the argument. Suppose that the function is given by their expansion (1.102). Consider the linear fractional transformation that preserves the origin $W = (a\epsilon)/(1 + b\epsilon)$, and the function $q(W) = f(\epsilon)$. Then $q_{[n/n]}$, provided that one of these approximations exist. In particular, the diagonal PA is invariant concerning the Euler transformation (1.100).
6. Diagonal PA are invariant under fractional linear transformations of functions. Let us analyse a function (1.102). Let

$$q(\epsilon) = \frac{a + bf(\epsilon)}{c + df(\epsilon)}.$$

If $c + df(\epsilon) \neq 0$, then

$$q_{[n/n]}(\epsilon) = \frac{a + bf_{[n/n]}(\epsilon)}{c + df_{[n/n]}(\epsilon)},$$

provided that there is $f_{[n/n]}(\epsilon)$. Because of this property infinite values of PA can be considered on a par with the end.

7. The PA can get the upper and lower bounds for $f_{[n/n]}(\epsilon)$. For the diagonal PA one has the estimate

$$f_{[n/n-1]}(\epsilon) \leq f_{[n/n]}(\epsilon) \leq f_{[n/n+1]}(\epsilon). \quad (1.108)$$

Typically, this estimate is valid for the function itself, i.e. $f_{[n/n]}(\epsilon)$ in Equation (1.108) can be replaced by $f(\epsilon)$.

8. Diagonal and close to it a sequence of PA often possess the property of autocorrection [163]–[166]. It consists of the following. To determine the coefficients of the numerator and denominator of PA one has to solve systems of LAE. This is an ill-posed procedure, so the coefficients of PA can be determined with large errors. However, these errors are in a certain sense of self-consistency, the PA can approximate the searching function with a higher accuracy. This is a radical difference between the PA and the Taylor series.

Autocorrection property is verified for a number of special functions. At the same time, even for elliptic functions the so-called Froissart doublets phenomenon arises, consisting of closely spaced zeros and poles to each other (but different and obviously irreducible) in the PA. This phenomenon is not of a numerical nature, but due to the nature of the elliptic function [232]. Thus, in general, having no information about the location of the poles of the PA, but relying solely on the PA (computed exactly), one cannot say that a good approximation for the approximated function is found.

To overcome these defects several methods are suggested, and in particular the smoothing method [35]. Its essence is that instead of the usual-term diagonal PA for complex functions $f_{[n/n]}(\epsilon) = p_n(\epsilon)/q_n(\epsilon)$ the following expression is used

$$f_{[n/n]}(\epsilon) = \frac{\overline{q_n(\epsilon)}p_n(\epsilon) + \overline{q_{n-1}(\epsilon)}p_{n-1}(\epsilon)}{q_n(\epsilon)\overline{q_n(\epsilon)} + q_{n-1}(\epsilon)\overline{q_{n-1}(\epsilon)}},$$

where \overline{f} denotes complex conjugation of f .

Now consider the question: in what sense can the available mathematical results on the convergence of the PA facilitate the solution of practical problems? Gonchar's theorem [120] states: if none of the diagonal PA $f_{[n/n]}(\epsilon)$ has poles in the circle of radius R , then the sequence $f_{[n/n]}(\epsilon)$ is uniformly convergent in the circle to the original function $f(\epsilon)$. Moreover, the absence of poles of the sequence of the $f_{[n/n]}(\epsilon)$ in a circle of radius R must be original and confirm convergence of the Taylor series in the circle. Since for the diagonal PA invariant under fractional linear maps we have $\epsilon \rightarrow (\epsilon)/(a\epsilon + b)$, the theorem is true for any open circle containing the point of splitting, and for any area, which is the union of these circles. The following theorem holds [87]: suppose the sequence of diagonal PA of the function $w(\epsilon)$, which is holomorphic in the unit disc and has no poles outside this circle. Then this sequence converges uniformly to $w(\epsilon)$ in the disc $|z| < r_0$, where $0.583R < r_0 < 0.584R$. A significant drawback in practice is the need to check all diagonal PA.

How can we use these results? Suppose that there are a few terms of the perturbation series and someone wants to estimate its radius of convergence R . Consider the interval $[0, \epsilon_0]$, where the truncated PS and the diagonal PA of the maximal possible order differ by no more than 5%. If none of the previous diagonal PA has poles in a circle of radius ϵ_0 , then it is a high level of confidence to assert that $R \geq \epsilon_0$ [9].

The procedure of constructing the PA is much less labor-intensive than the construction of higher approximations of the PS. The PA is not limited to power series, but to the series of orthogonal polynomials. PA is locally the best rational approximation of a given power series. They are constructed directly on its odds and allow the efficient analytic continuation of the series outside its circle of convergence, and their poles in a certain sense localize the singular points (including the poles and their multiplicities) of the continuation function at the corresponding region of convergence and on its boundary. This PA is fundamentally different from

rational approximations to (fully or partially) fixed poles, including those from the polynomial approximation, in which case all the poles are fixed in one, infinity, the point. Currently, the PA method is one of the most promising nonlinear methods of summation of power series and the localization of its singular points. This includes the reason why the theory of the PA turned into a completely independent section of approximation theory, and these approximations have found a variety of applications both directly in the theory of rational approximations, and in perturbation theory. Thus, the main advantages of PA compared with the Taylor series are as follows:

1. Typically, the rate of convergence of rational approximations greatly exceeds the rate of convergence of polynomial approximation. For example, the function e^ε in the circle of convergence approximated by rational polynomials $P_n(\varepsilon)/Q_n(\varepsilon)$ is 4^n times better than an algebraic polynomial of degree $2n$. More tangible it is a property for functions of limited smoothness. Thus, the function $|\varepsilon|$ on the interval $[-1, 1]$ cannot be approximated by algebraic polynomials, so that the order of approximation was better than $1/n$, where n is the degree of polynomial. PA gives the rate of convergence $\sim \exp(-\sqrt{2n})$.
2. Typically, the radius of convergence of rational approximation is large compared with power series. Thus, for the function $\arctan(x)$ Taylor polynomials converge only if $|\varepsilon| \leq 1$, and PA - everywhere in $C \setminus ((-\infty, -i] \cup [i, i\infty))$.
3. PA can establish the position of singularities of the function.

Similarly, the PA method is a method of continued fractions [136]. There are several types of continued fractions. The regular C -fraction has the form of an infinite sequence, in which the N -th term can be written as follows

$$f_N(\varepsilon) = a + \frac{c_0}{1 + \frac{c_1\varepsilon}{1 + \frac{c_2\varepsilon}{1 + \frac{\vdots}{1 + \frac{c_{N+1}\varepsilon}{1 + c_N\varepsilon}}}}} \quad (1.109)$$

The coefficients c_i are obtained after the decomposition of expression (1.109) into a Maclaurin series, and then equating the coefficients of equal powers of ε . When $a = 0$ one obtains the fraction of Stieltjes or S -fraction. For the function of Stieltjes

$$S(\varepsilon) = \int_0^\infty \frac{\exp(-t)}{1 + \varepsilon t} dt,$$

the coefficients of expansion (1.109) have the form: $a = 0$, $c_0 = 1$, $c_{2n-1} = c_{2n} = n$, $n \geq 1$.

Description of the so-called J -, T -, P -, R -, g -fractions, algorithms for their construction and the range of applicability are described in detail in [136].

Continued fractions are a special case of continuous functional approximation [44]. This is the sequence in which the $(n + 1)$ -th term $c_n(\varepsilon)$ has the form n -th iteration of a function $F(\varepsilon)$. For the Taylor series one obtains $F(\varepsilon) = 1 + \varepsilon$, for the continuous fraction $F(\varepsilon) = 1/(1 + \varepsilon)$.

If $F(\varepsilon) = \exp(\varepsilon)$ one obtains a continuous exponential approximation

$$c_n(\varepsilon) = a_0 \exp\{a_1 \varepsilon \exp[a_2 \varepsilon \dots \exp(a_n \varepsilon)]\},$$

for $F(\varepsilon) = \sqrt{1 + \varepsilon}$

$$c_n(\varepsilon) = a_0 \sqrt{1 + a_1 \varepsilon \sqrt{1 + a_2 \varepsilon \sqrt{1 + \dots a_{n-1} \varepsilon \sqrt{1 + a_n \varepsilon}}}},$$

for $F(\varepsilon) = \ln 1 + \varepsilon$

$$c_n(\varepsilon) = a_0 \ln\{a_1 \varepsilon \ln[a_2 \varepsilon \dots \ln(a_n \varepsilon)]\}.$$

In some cases, such approximations can converge significantly faster than power series. As an example, we take a solution of the transcendental equation

$$x = \varepsilon \ln x$$

for large values of ε (see [23])

$$x_0 = \varepsilon \ln \varepsilon; \quad x_1 = \varepsilon \ln(\varepsilon \ln \varepsilon); \quad x_2 = \varepsilon \ln[\varepsilon \ln(\varepsilon \ln \varepsilon)]; \dots$$

1.4 Some Applications of PA

1.4.1 Accelerating Convergence of Iterative Processes

The efficiency of PA or other methods of summation depends largely on the availability of higher approximations of the asymptotic process. Sometimes they can be obtained by using computer algorithms [188], but in general this problem remains an open one. Iterative methods are significantly easier to be implemented. As a result of an iterative procedure a sequence of S_n is obtained. Suppose that it converges and has a limit value. We introduce the parameter a defined by the ratio

$$a = \lim_{n \rightarrow \infty} \frac{S_{n+1} - S_n}{S_n - S}.$$

It is called superlinear convergence, if $a = 0$, a linear for $a < 1$ and logarithmic at $a = 1$. The biggest issues are, of course, logarithmically convergent sequences. Very often linearly convergent sequences may also cause a problem. Therefore, it is often necessary to improve the convergence. One method of improving the convergence is to move to a new sequence T_n with the aid of a transformation so that

$$\lim_{n \rightarrow \infty} \frac{T_n - S_n}{S_n - S} = 0.$$

In such cases we say that the sequence T_n converges faster than sequence S_n . There are linear and nonlinear methods to improve convergence. Linear methods are described by formulas

$$T_n = \sum a_{ni} S_i, \quad n = 0, 1, 2, \dots,$$

where the coefficients a_{ni} do not depend on the terms of the sequence S_n .

Since linear methods improve the convergence of a restricted class of sequences, currently nonlinear methods belong to the most popular ones. Among them the Aitken method [18] stands out for its easiness, which is described by the formula

$$T_n = S_n - \frac{(S_{n+1} - S_n)(S_n - S_{n-1})}{S_{n+1} - 2S_n + S_{n-1}}, \quad n = 0, 1, 2, \dots \quad (1.110)$$

The Aitken method accelerates the convergence of all linear and many of logarithmically convergent sequences. It is very easy to calculate, and in some cases it can be applied iteratively. A natural generalization of the Aitken transformation is the Shanks transformation [224] of the form

$$T_p^{sh} = \frac{D_{kp}^{(1)}}{D_{kp}^{(1)}}, \quad (1.111)$$

where

$$D_{kp}^{(1)} = \begin{vmatrix} S_{p-k} & S_{p-k+1} & \dots & S_p \\ \Delta S_{p-k} & \Delta S_{p-k+1} & \dots & \Delta S_p \\ \dots & \dots & \dots & \dots \\ \Delta S_{p-1} & \Delta S_p & \dots & \Delta S_{p+k-1} \end{vmatrix},$$

$$D_{kp}^{(2)} = \begin{vmatrix} 1 & 1 & \dots & 1 \\ \Delta S_{p-k} & \Delta S_{p-k+1} & \dots & \Delta S_p \\ \dots & \dots & \dots & \dots \\ \Delta S_{p-1} & \Delta S_p & \dots & \Delta S_{p+k-1} \end{vmatrix},$$

$$\Delta S_k = S_{k+1} - S_k.$$

Equation (1.111) is called the Shanks transformation of the order k of the sequences S_k to the sequence S_k . For $k = 1$ one obtains the Aitken transform (1.110). Shanks method requires the calculation of determinants, which is not always easy. One can also use the Wynn algorithm, which is described by the formulas

$$T_{-1}^{(n)} = 0, \quad T_0^{(n)} = S_n, \quad T_{k+1}^{(n)} = T_{k+1}^{(n+1)} + \frac{1}{T_k^{(n+1)} - T_k^{(n)}}. \quad (1.112)$$

The Wynn algorithm is related to the transformation of Shanks (1.111) in the following way

$$T_{2k}^{(n)} = T_k^{(sh)}(S_n), \quad T_{2k+1}^{(n)} = \frac{1}{T_k^{(sh)}}(\Delta S_n).$$

The Wynn algorithm is a quadratic convergent method for solving systems of nonlinear equations [68], [74], [114]. There are many other techniques for accelerating sequences' convergence. One can use them consistently, for example, to convert the original sequence into a linearly convergent one, and then apply the method of Aitken. One can also use different methods to improve convergence, at each stage by comparing the obtained results [67]. All the described methods have a close relationship with the PA. The Aitken method corresponds to the PA $[n/1]$, the Shanks method to the PA $[p/k]$, and for the method of Wynn one obtains $T_{2k}^{(n)} = [n + k/k]$.

1.4.2 Removing Singularities and Reducing the Gibbs-Wilbraham Effect

Consider the problem of uniform plane flow of an incompressible inviscid fluid streamlines a thin elliptic airfoil ($|x| \leq 1$, $|y| \leq \varepsilon$, $\varepsilon \ll 1$). The expression for the relative velocity q^* of the flow follows [244]:

$$q^* = \frac{q}{V} = \frac{(1 + \varepsilon)\sqrt{1 - x^2}}{\sqrt{1 - x^2(1 + \varepsilon^2)}}, \quad (1.113)$$

where V is the free-stream speed.

The splitting of the r.h.s. of Equation (1.113) in a series of ε can be expressed as

$$q^*(x, \varepsilon) = 1 + \varepsilon - \frac{1}{2}\varepsilon^2 \frac{x^2}{1 - x^2} - \frac{1}{2}\varepsilon^3 \frac{x^2}{1 - x^2} + \dots \quad (1.114)$$

This expression diverges at $x = 1$. No wonder it is not: the expansion (1.114) is obtained as a result of the limiting process $\lim_{\varepsilon \rightarrow 0} q(x, \varepsilon)$, $x > 1$, and to get the value of $q(1, \varepsilon)$, it is necessary to perform the limit as $\lim_{x \rightarrow 1} q(x, \varepsilon)$ for $\varepsilon > 0$. Divergence of series (1.114), when $x = 1$ indicates that the limit processes cannot be interchanged. Now, let us apply PA to the r.h.s. of Equation (1.114) and then pass to the limit $x \rightarrow 1$. After trying various options, we conclude that the best result is given by the PA

$$q^*(x, \varepsilon) = \frac{(1 - x^2)(1 + \varepsilon)}{1 - x^2}. \quad (1.115)$$

Numerical results for $\varepsilon = 0.5$ are shown in Figure 1.6, where the dashed curve denotes the solution (1.114), curves 1 and 2 the exact solution (1.115) and the PA (1.115), respectively. It is seen that the use of PA significantly improves the accuracy of the approximate solution.

PA can be also successfully applied for suppression of the Gibbs-Wilbraham effect (see discussion in references [36], [69], [95], [196], [218]). Consider, for example, the function $\text{sign} x$ of the form

$$\text{sign} x = \begin{cases} -1, & -\pi < x < 0, \\ 1, & 0 < x < \pi. \end{cases}$$

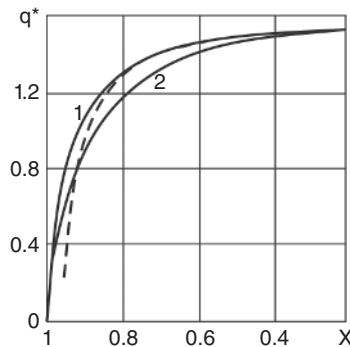

Figure 1.6 Removing singularities by the PA

Its Fourier series expansion has the form

$$\text{sign } x = \frac{4}{\pi} \sum_{j=0}^{\infty} \frac{\sin(2j+1)x}{2j+1}. \quad (1.116)$$

Direct summation of series (1.116) leads to the Gibbs-Wilbraham effect in the neighborhood of $x = 0$, while the defect of convergence reaches 18%, i.e. instead of 1 one obtains the value of 1.1789797 Diagonal PA for series (1.116) can be written as follows

$$\text{sign } x_{[N/M]} = \frac{\sum_{j=0}^{[(N-1/2)]} q_{2j+1} \sin((2j+1)x)}{1 + \sum_{j=0}^{[(N/2)]} s_{2j} \cos(2jx)}, \quad (1.117)$$

where

$$q_{2j+1} = \frac{4}{\pi}(2j+1) \left[\frac{1}{(2j+1)^2} + \sum_{i=1}^{[N/2]} \frac{s_{2i}}{(2j+1)^2 - (2i)^2} \right],$$

$$s_{2i} = 2(-1)^i \frac{(N!)^4 (2N+2i)! (2N-2i)!}{(N-1)! (N+1)! (N-2i)! (N+2i)! [(2N)!]^2}.$$

Numerical studies show that the Gibbs-Wilbraham effect for PA (1.117) does not exceed 2% [196].

1.4.3 Localized Solutions

We consider the stationary Schrödinger equation

$$\nabla^2(x, y) - u(x, y) + u^3(x, y) = 0. \quad (1.118)$$

We seek the real, localized axisymmetric solutions of the Equation (1.118). In polar coordinates (ξ, θ) we construct a solution $\varphi(\xi)$, which does not depend on θ . As a result, we obtain the following BVP

$$\varphi''(\xi) + \frac{1}{\xi} \varphi'(\xi) - \varphi(\xi) + \varphi^3(\xi) = 0, \quad (1.119)$$

$$\varphi(x) = 0, \quad (1.120)$$

$$\lim_{\xi \rightarrow \infty} \varphi(\xi) = 0. \quad (1.121)$$

BVP (1.119)–(1.121) can be regarded as an eigenvalue problem, and the role of an eigenvalue is unknown quantity $A = \varphi(0)$. This problem plays an important role in nonlinear optics, quantum field theory, and theory of magnetic media. As shown in [191], BVP (1.119)–(1.121) has a countable set of “eigenvalues” A_n , the solution $\varphi(\xi, A_n)$ has exactly n zeros, and the solution $\varphi(\xi, A_0)$ has no zeros and decreases monotonically on ξ . That is the last solution, which is the most interesting from the standpoint of physical applications, and we will focus on obtaining it.

The problem of computing the decaying solutions of BVP (1.119)–(1.121) is identical to the problem of computing homoclinic orbits in the 3D phase space for the nonlinear oscillator, or equivalently, for computing the initial conditions for these orbits (see [99]).

Since the solutions sought are expected to be analytical functions of ξ , they can be expressed in the Maclaurin series about $\xi = 0$:

$$\varphi(\xi) = A_0 + \sum_{j=1}^{\infty} C_{2j} \xi^{2j}. \quad (1.122)$$

Substituting Ansatz (1.122) into Equation (1.119), producing a splitting of the powers of the ξ and solving the relevant equations, one obtains [99]

$$\begin{aligned} C_2 &= 0.25A_0(1 - A_0^2); & C_4 &= 0.25C_2\tilde{C}; & C_6 &= \frac{C_4}{6} - \frac{3A_0^2\tilde{C}^2}{16}; \\ C_8 &= \frac{1}{64}(\tilde{C}C_6 - 6A_0C_2C_4 - C_2^3); \\ C_{10} &= -0.01(\tilde{C}C_8 + 6A_0C_2C_6 + 3A_0C_4^2 + 3C_2^2C_4); \\ C_{12} &= -\frac{1}{144}(-\tilde{C}C_{10} + 6A_0C_2C_8 + 6A_0C_4C_6 + 3C_2c_4^2), \end{aligned}$$

where $\tilde{C} = 1 - 3A_0^2$.

Then we construct PA for the truncated series (1.122) of the form

$$\varphi(\xi) = \frac{A_0 + \sum_{j=0}^N a_{2j} \xi^{2j}}{1 + \sum_{k=1}^N b_{2j} \xi^{2k}}. \quad (1.123)$$

All coefficients in Equation (1.123) can be parameterized in terms of A_0 , $a_{2j} = a_{2j}(A_0)$, $b_{2j} = b_{2j}(A_0)$, and the PA becomes a one-parameter family of analytical approximations of the searching solution. Then, we compute the value of A_0 for which PA (1.123) decays to zero as ξ tends to infinity. It gives us conditions

$$a_{2j}(A_0) = 0, \quad b_{2j}(A_0) \neq 0. \quad (1.124)$$

One can compute the PA (1.123), then imposing the condition (1.124), the following convergent values of A_0 for varying orders $2N$ is obtained

N	1	2	3	4
A_0	$\pm\sqrt{3}$	± 2.20701	± 2.21121	± 2.21200

The numerical solution gives $A_0 \approx \pm 2.206208$, the difference between numerical and analytical solutions for $N = 4$ is 0.26%.

1.4.4 Hermite-Padé Approximations and Bifurcation Problem

PA can successfully work with functions having poles. However, it often becomes necessary to explore functions with branch points, and construct all their branches. In that case, one can use Hermite-Padé approximations [94], [220], [221]. Suppose it comes to a function with the expansion

$$f(\varepsilon) = \sum_{n=1}^{\infty} u_n \varepsilon^n, \quad (1.125)$$

and we managed to find the first few coefficients of this series

$$f_N(\varepsilon) = \sum_{n=1}^N u_n \varepsilon^n.$$

If it is known that this function has a branch point, we can try to transform the original series (1.125) in an implicit function

$$F(\varepsilon, f) = 0$$

and determine all required branches of it.

For this purpose we construct a polynomial $F_p(\varepsilon, f)$ of degree $p \geq 2$

$$F_p(\varepsilon, f) = \sum_{m=1}^p \sum_{k=0}^m C_{m-k,k} \varepsilon^{m-k} f^k.$$

It was assumed $C_{0,1} = 1$, and the remaining coefficients must be determined from the condition

$$F_p(\varepsilon, f_N(\varepsilon)) = O(\varepsilon^{N+1}) \text{ at } \varepsilon \rightarrow 0. \quad (1.126)$$

Polynomial F_p contains $0.5(p^2 + 3p - 2)$ unknowns, the condition (1.126) yields N linear algebraic equations, and hence, $N = 0.5(p^2 + 3p - 2)$. Once the polynomial F_p is found, one can easily find p branches of the solution from the equation

$$F_p = 0.$$

For the analysis of bifurcations of these solutions one can use Newton's polygon [237]. If a priori information about the searching function is known, it can be taken into account for constructing the polynomial F_p .

1.4.5 Estimates of Effective Characteristics of Composite Materials

We consider a macroscopically isotropic 2D composite material consisting of a matrix with inclusions. The aim is to determine the effective conductivity q from the known matrix (q_1) and inclusions (q_2) conductivities and the volume fraction (φ). As shown in [234], if we take $\varepsilon = (q_2/q_1) - 1$ as a small parameter value, the required effective conductivity can be written as follows

$$\frac{q}{q_1} = 1 + \varphi\varepsilon - 0.5\varphi(1 - \varphi)\varepsilon^2 + O(\varepsilon^3). \quad (1.127)$$

Using the first two terms of expansion (1.127), one obtains

$$\frac{1}{1 + \varphi\varepsilon} \leq \frac{q}{q_1} \leq 1 + \varphi\varepsilon,$$

hence the Wiener bounds follow

$$\left(\frac{1-\varphi}{q_1} + \frac{\varphi}{q_2}\right)^{-1} \leq q \leq (1-\varphi)q_1 + \varphi q_2.$$

Three terms of the expansion (1.127) give a well-known Hashin-Shtrikman lower bound, originally based on variational principles

$$q_1 + \frac{\varphi}{\frac{1}{q_2 - q_1} + \frac{1-\varphi}{2q_1}} \leq q, \tag{1.128}$$

while $q_2 > q_1$; for $q_2 < q_1$ the inequalities in Equation (1.128) should be changed to the opposite.

Replacement $q_2 \leftrightarrow q_1, \varphi \leftrightarrow 1 - \varphi$ gives an upper Hashin-Shtrikman bound

$$q \leq q_2 + \frac{1-\varphi}{\frac{1}{q_1 - q_2} + \frac{\varphi}{2q_2}}. \tag{1.129}$$

The first three terms in the expansion (1.127) do not depend on the specific geometry of the inclusions, so the estimates (1.128), (1.129) are the most common ones. Specifying the type of inclusions, we can construct the following terms in the expansion and using the PA or continued fractions, to get narrower and narrower bounds for the unknown effective conductivity.

1.4.6 Continualization

We study a chain of $n + 2$ material points with the same masses m , located in equilibrium states in the points of the axis x with coordinates $jh(j = 0, 1, \dots, n, n + 1)$ and suspended by elastic couplings of stiffness c (Figure 1.7) [8].

According to Hooke’s law the elastic force acting on the j -th mass is as follows

$$\sigma_j(t) = c[y_{j+1}(t) - y_j(t)] - c[y_j(t) - y_{j-1}(t)] = c[y_{j-1}(t) - 2y_j(t) + y_{j+1}(t)],$$

where $j = 1, 2, \dots, n$ and $y_j(t)$ is the displacement of the j -th material point from its static equilibrium position.

Applying Newton’s second law one obtains the following system of ODEs governing chain dynamics

$$m\sigma_{jt}(t) = c(\sigma_{j+1} - 2\sigma_j + \sigma_{j-1}), j = 1, 2, \dots, n. \tag{1.130}$$

Let us suppose the following BCs

$$\sigma_0(t) = \sigma_{n+1}(t) = 0. \tag{1.131}$$

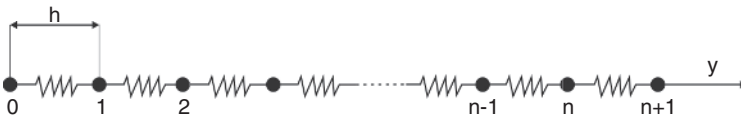

Figure 1.7 A chain of elastically coupled masses

For large values of n usually continuum approximation of discrete problem is applied. In our case it takes the form of

$$m\sigma_{tt}(x, t) = ch^2\sigma_{xx}(x, t), \quad (1.132)$$

$$\sigma(0, t) = \sigma(\ell, t) = 0. \quad (1.133)$$

Formally, one can rewrite Equation (1.130) as a pseudo-differential equation:

$$m\frac{\partial^2\sigma}{\partial t^2} + 4c\sin^2\left(-\frac{ih}{2}\frac{\partial}{\partial x}\right)\sigma = 0. \quad (1.134)$$

The pseudo-differential operator can be split into the McLaurin series as follows

$$\begin{aligned} \sin^2\left(-\frac{ih}{2}\frac{\partial}{\partial x}\right) &= -\frac{1}{2}\sum_{k=1}^{\infty}\frac{h^{2k}}{(2k)!}\frac{\partial^{2k}}{\partial x^{2k}} \\ &= -\frac{h^2}{4}\frac{\partial^2}{\partial x^2}\left(1 + \frac{h^2}{12}\frac{\partial^2}{\partial x^2} + \frac{h^4}{360}\frac{\partial^4}{\partial x^4} + \frac{h^6}{10080}\frac{\partial^6}{\partial x^6}\right). \end{aligned} \quad (1.135)$$

Retaining only the first term in the last line of Equation (1.135), one obtains a continuum approximation (1.132). Keeping the first three terms in Equation (1.135), the following model is obtained

$$m\frac{\partial^2\sigma}{\partial t^2} = ch^2\left(\frac{\partial^2}{\partial x^2} + \frac{h^2}{12}\frac{\partial^4}{\partial x^4} + \frac{h^4}{360}\frac{\partial^6}{\partial x^6}\right). \quad (1.136)$$

In the case of periodic BCs for a discrete chain one obtains the following BCs for Equation (1.136):

$$\sigma = \sigma_{xx} = \sigma_{xxxx} = 0 \text{ for } x = 0, \ell. \quad (1.137)$$

BVP (1.136), (1.137) is of the 6th order in spatial variables. Using PA we can obtain a modified continuum approximation of the 2nd order. If only two terms are left in the r.h.s. of Equation (1.135), then the PA can be cast into the following form

$$\frac{\partial^2}{\partial x^2} + \frac{h^2}{12}\frac{\partial^4}{\partial x^4} \approx \frac{\frac{\partial^2}{\partial x^2}}{1 - \frac{h^2}{12}\frac{\partial^2}{\partial x^2}}.$$

For justification of this procedure Fourier or Laplace transforms can be used.

The corresponding so-called quasi-continuum model reads

$$m\left(1 - \frac{h^2}{12}\frac{\partial^2}{\partial x^2}\right)\sigma_{tt} - ch^2\sigma_{xx} = 0. \quad (1.138)$$

The BCs for Equation (1.138) have the form (1.133).

1.4.7 Rational Interpolation

In this subsection we follow [108]. A simple way to approximate a function is to choose a sequence of points

$$a = x_0 < x_1 < x_2 \cdots < x_n = b,$$

and to construct the interpolating polynomial $p_n(x)$

$$p_n(x_i) = f(x_i), \quad i = 0, 1, 2, \dots, n.$$

However, as is well-known $p_n(x)$ may not be a good approximation to f , and for large $n \gg 1$ it can exhibit wild oscillations. If we are free to choose the distribution of the interpolation points x_i , one remedy is to cluster them near the end-points of the interval $[a, b]$, for example using various kinds of Chebyshev points.

A very popular alternative nowadays is to use splines (piecewise polynomials), which have become a standard tool for many kinds of interpolation and approximation algorithms, and for geometric modeling. However, it has been known for a long time that the use of rational functions can also lead to much better approximations than ordinary polynomials. In fact, both polynomial and rational interpolation, can exhibit exponential convergence when approximating analytic functions.

In “classical” rational interpolation, one chooses some M and N such that $M + N = n$ and fits a rational function of the form p_M/q_N to the values $f(x_i)$, where p_M and q_N are polynomials of degrees M and N , respectively. If n is even, it is typical to set $M = N = n/2$, and some authors have reported excellent results. The main drawback, though, is that there is no control over the occurrence of poles in the interval of interpolation.

In reference [51] it has been suggested that it might be possible to avoid poles by using rational functions of higher degree. Authors considered algorithms, which fit rational functions, whose numerator and denominator degrees can both be as high as n . This is a convenient class of rational interpolants because such an interpolant can be written in so-called barycentric form

$$r(x) = \frac{\sum_{i=0}^n \frac{\lambda_i}{x-x_i} f(x_i)}{\sum_{i=0}^n \frac{\lambda_i}{x-x_i} f(x_i)}$$

for some real values λ_i . Thus, it suffices to choose the weights λ_i in order to specify r , and the idea is to search for weights, which give interpolants r that have no poles and preferably good approximation properties. Various approaches are described in [108], in particular, one can choose $\lambda_i = (-1)^i$, $i = 0, 1, 2, \dots, n$.

1.4.8 Some Other Applications

PA is widely used for the construction of solitons and other localized solutions of nonlinear problems, even in connection with the appeared term “padeon” (see [155], [156] for more details).

As a simple model, we consider the nonlinear BVP

$$y'' - y + 2y^3 = 0, \tag{1.139}$$

$$y(0) = 1, \quad y(\infty) = 0, \tag{1.140}$$

that has an exact localized solution

$$y = \cosh^{-1}(x). \tag{1.141}$$

Quasilinear asymptotics give a solution in the following form

$$y = Ce^{-x}(1 - 0.25C^2e^{-2x} + 0.0625C^4e^{-4x} + \dots), \quad C = \text{const.} \quad (1.142)$$

It is easy to verify that with reconstructing the truncated series (1.142) in the PA, and with determining the constant C from the BCs (1.140), we arrive at the exact solution (1.141).

It is interesting also to use the PA to problems with the phenomenon of “blow-up”, when the solution goes to infinity at a finite value of the argument. For example, the Cauchy problem

$$\frac{dx}{dt} = \alpha x + \varepsilon x^2, \quad x(0) = 1, \quad 0 < \varepsilon \ll \alpha \ll 1, \quad (1.143)$$

has the exact solution

$$x(t) = \frac{\alpha \exp(\alpha t)}{\alpha + \varepsilon - \varepsilon \exp(\alpha t)}, \quad (1.144)$$

which tends to infinity for $t \rightarrow \ln[(\alpha + \varepsilon)/\varepsilon]$.

Regular asymptotic expansion

$$x(t) \sim \exp(\alpha t) - \varepsilon \alpha^{-1} \exp(\alpha t)[1 - \exp(\alpha t)] + \dots$$

cannot describe this phenomenon, but the use of the PA gives the exact solution (1.144).

PA allows us to expand the scope of the known approximate methods. For example, in the method of harmonic balance the representation of the solution of a rational function of the type

$$x(t) = \frac{\sum_{n=0}^N \{A_n \cos[(2n+1)\omega t] + B_n \sin[(2n+1)\omega t]\}}{1 + \sum_{n=0}^N \{C_n \cos(2m\omega t) + D_n \sin(2m\omega t)\}}$$

substantially increases the accuracy of approximation [128], [187].

PA can be used effectively to solve ill-posed problems. This could include reconstruction of functions in the presence of noise ([116]–[118]), various problems of dehomogenization (i.e., determining the components of a composite material on its homogenized characteristics) [81], etc. We must also mention 2D PA being illustrated and discussed in [86]. For other applications of PA see [22], [26], [27], [33], [40], [41], [45], [54], [82], [83], [85], [89], [90], [98], [102], [125], [126], [127], [135], [172], [177], [190], [249].

1.5 Matching of Limiting Asymptotic Expansions

1.5.1 Method of Asymptotically Equivalent Functions for Inversion of Laplace Transform

This method was originally proposed by Slepyan and Yakovlev for the treatment of integral transformations. Here is a description of this method, following [229]. Suppose that the Laplace transform of a function of a real variable $f(t)$ is

$$F(s) = \int_0^{\infty} f(t)e^{-st} ds.$$

In order to obtain an approximate expression for the inverse transform, it is necessary to clarify the behavior of the transform in vicinity of the points $s = 0$ and $s = \infty$, and to determine the nature and location of its singular points, as well as whether they lie on the exact boundary of the regularity or near it. Then the transform $F(s)$ is replaced by the function $F_0(s)$, allowing the exact inversion and satisfying the following conditions:

1. Functions $F_0(s)$ and $F(s)$ are asymptotically equivalent at $s \rightarrow \infty$ and $s \rightarrow 0$, i.e.

$$F_0(s) \sim F(s) \text{ at } s \rightarrow 0 \text{ and } s \rightarrow \infty.$$

2. Singular points of the functions $F_0(s)$ and $F(s)$, located on the exact boundary of the regularity, coincide.

Free parameters of the function $F_0(s)$ are chosen in such a way that they satisfy the conditions of the approximation of $F(s)$ in the sense of minimum relative error for all real values $s \geq 0$:

$$\min \left\{ \max \left| \frac{F_0(s, \alpha_1, \alpha_2, \dots, \alpha_k)}{F(s)} - 1 \right| \right\}. \quad (1.145)$$

Condition (1.145) is achieved by variation of free parameters α_i . Often the implementation of equalities

$$\int_0^\infty F_0(s) ds = \int_0^\infty F(s) ds$$

or $F'_0 \sim F'_0$ at $s \rightarrow 0$ leads to a rather precise fulfillment of requirements (1.145).

Constructed in such a way function is called asymptotically equivalent function (AEF).

Here is an example of constructing AEF. Find the inverse transform if the Laplace transform is given by the modified Bessel function [2], Chapter 9:

$$K_0(s) = -\ln(s/2)I_0(s) + \sum_{k=0}^{\infty} \frac{s^{2k}}{2^{2k}(k!)^2} \Psi(k+1) \quad (1.146)$$

where $\Psi(z)$ is the psi (digamma) function [2], Chapter 6.

For pure imaginary values of the argument $s(s = iy; 0 < |y| < \infty)$ function $K_0(s)$ has no singular points. Consequently, we can restrict the study of its behavior for $s \rightarrow 0$ and $s \rightarrow \infty$. The corresponding asymptotic expressions are [2], Chapter 9:

$$K_0(s) = -\left[\ln \frac{s}{2} + \gamma \right] + O(s), \quad s \rightarrow 0, \quad (1.147)$$

$$K_0(s) = \sqrt{\frac{\pi}{2s}} e^{-s} \left[1 + O\left(\frac{1}{s}\right) \right], \quad s \rightarrow \infty,$$

where γ is the Euler's constant ($\gamma = 1.781\dots$)[] (note the typo in the first formula (1.147) in [229]).

The analyzed Laplace transform has a branch point of the logarithmic type, branch point of an algebraic type, and an essential singularity. These singular points need to be stored in the structure of the zero approximation. The most simple way to obtain such a structure is to combine of two asymptotic representations (1.147), so that they mutually do not distort each

other and contain free parameters, which could be disposed of in the future. As a result, we arrive at the zeroth order approximation

$$F_0(s) = e^{-s} \left[\ln \frac{s+\alpha}{s} + \sqrt{\frac{\pi}{2}} \frac{1}{\sqrt{s+\beta}} \right], \quad (1.148)$$

where α and β are the free parameters.

It is easy to see that expression (1.148) has the correct asymptotic behavior $s \rightarrow \infty$. The free parameters are determined from the condition of coincidence of the asymptotics of the functions $K_0(s)$ and $F_0(s)$ for $s \rightarrow 0$, and the equality of integrals

$$\int_0^\infty F_0(s) ds = \int_0^\infty K_0(s) ds.$$

As a result of calculations one obtains a system of transcendental equations

$$\begin{aligned} \ln \alpha + \sqrt{\frac{\pi}{2\beta}} &= \ln 2 - \gamma, \\ \ln \alpha - e^\alpha \text{Ei}(-\alpha) + \gamma + \frac{\pi}{\sqrt{2}} e^\beta [1 - \text{erf}(\sqrt{2})] &= \frac{\pi}{2}, \end{aligned}$$

where $\text{Ei}(\dots)$ is the the sine integral [2], Chapter 7. $\text{erf}(\dots)$ is the error function [2] (note typo in these formulas in [229]).

Solving the prescription system numerically, one finds $\alpha = 0.3192$, $\beta = 0.9927$.

Then the approximate inverse transform can be written as follows:

$$f_0(t) = \left\{ \frac{1 - \exp[-\alpha(t-1)]}{t-1} + \frac{\exp[-\beta(t-1)]}{\sqrt{2(t-1)}} \right\} H(t-1). \quad (1.149)$$

The exact expression for the function $f(t)$ is

$$f(t) = \frac{1}{\sqrt{t^2 - 1}} H(t-1). \quad (1.150)$$

Comparison of exact (1.150) (solid curve) and approximate (1.149) (dotted curve with circles) inversions is shown in Figure 1.8. As can be seen, a satisfactory result is obtained even in the zero approximation.

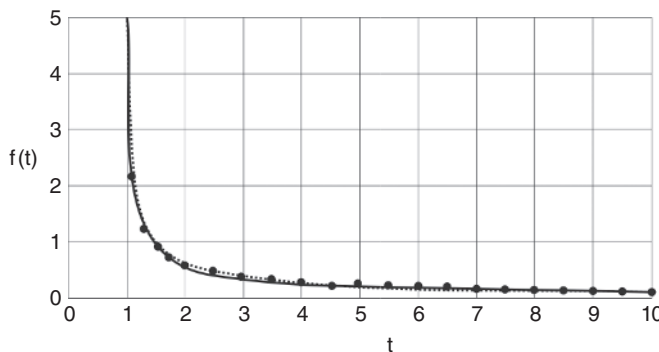

Figure 1.8 Comparison of the exact Laplace transform inversion with the treatment by the method of AEFs

Analogously, one can construct AEFs for inverse sine and cosine Fourier transforms, Hankel and other integral transforms.

1.5.2 Two-Point PA

The analysis of numerous examples confirms usually implemented a sort of “complementarity principle”: if for $\epsilon \rightarrow 0$ one can construct a physically meaningful asymptotics, there is a nontrivial asymptotics also for $\epsilon \rightarrow \infty$. The most difficult in terms of the asymptotic approach is the intermediate case of $\epsilon \sim 1$. In this domain numerical methods typically work well, however, if the task is to investigate the solution depending on the parameter ϵ , then it is inconvenient to use different solutions in different areas. Construction of an unified solution on the basis of limiting asymptotics is not a trivial task, which can be summarized as follows: we know the behavior of functions in zones I and III (Figure 1.9); we need to construct it in the zone II. For this purpose one can use a two-point PA (TPPA). We give the definition following [30].

Let

$$F(\epsilon) = \sum_{i=0}^{\infty} c_i \epsilon^i \quad \text{at } \epsilon \rightarrow 0, \tag{1.151}$$

$$F(\epsilon) = \sum_{i=0}^{\infty} c_i \epsilon^{-i} \quad \text{at } \epsilon \rightarrow \infty. \tag{1.152}$$

Its TPPA is a rational function of the form

$$f_{[n/m]}(\epsilon) = \frac{a_0 + a_1 \epsilon + \dots + a_n \epsilon^n}{1 + b_1 \epsilon + \dots + b_m \epsilon^m}$$

with $k \leq m + n - 1$ coefficients, which are determined from the condition

$$(1 + b_1 \epsilon + \dots + b_m \epsilon^m)(c_0 + c_1 \epsilon + c_2 \epsilon^2 + \dots) = a_0 + a_1 \epsilon + \dots + a_n \epsilon^n,$$

and the remaining $m + n - k$ coefficients of a similar condition for ϵ^{-1} .

As an example of TPPA using for matching of limiting asymptotics, consider the solution of the Van der Pol equation:

$$\ddot{x} + \epsilon \dot{x}(x^2 - 1) + x = 0.$$

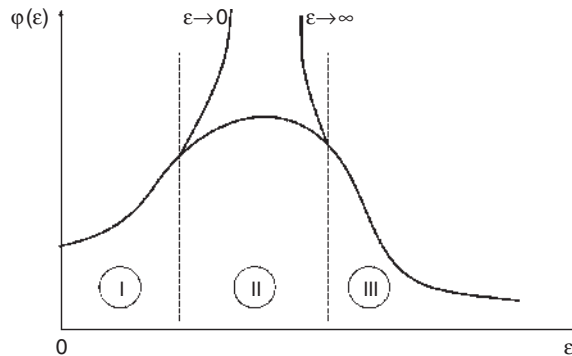

Figure 1.9 Matching of asymptotic solutions

Asymptotic expressions of the oscillation period for small and large values of ε are [3], [73], [133]:

$$T = 2\pi \left(1 + \frac{\varepsilon^2}{16} - \frac{5\varepsilon^4}{3072} \right) \quad \text{at } \varepsilon \rightarrow 0, \quad (1.153)$$

$$T = \varepsilon(3 - 2 \ln 2) \quad \text{at } \varepsilon \rightarrow \infty. \quad (1.154)$$

For constructing TPPA we use the four conditions at $\varepsilon \rightarrow 0$ and the two conditions at $\varepsilon \rightarrow \infty$, then

$$T(\varepsilon) = \frac{a_0 + a_1\varepsilon + a_2\varepsilon^2 + a_3\varepsilon^3}{1 + b_1\varepsilon + b_2\varepsilon^2}, \quad (1.155)$$

where

$$a_0 = 2\pi, a_1 = \frac{\pi^2(3 - 2 \ln 2)}{4(3 - 2 \ln 2)^2 - \pi^2}, \quad a_2 = \frac{\pi(3 - 2 \ln 2)^2}{2[4(3 - 2 \ln 2)^2 - \pi^2]},$$

$$a_3 = \frac{\pi^2(3 - 2 \ln 2)}{16[4(3 - 2 \ln 2)^2 - \pi^2]}, \quad b_1 = \frac{\pi(3 - 2 \ln 2)}{2[4(3 - 2 \ln 2)^2 - \pi^2]},$$

$$b_2 = \frac{\pi^2}{16[4(3 - 2 \ln 2)^2 - \pi^2]}.$$

Table 1.5 shows the results of the comparison of numerical values of the period, given in [3], [6] with the results calculated by formula (1.155).

Table 1.5 Comparison of numerical results and calculations using the TPPA

ε	T numerical	TPPA
1	6.66	6.61
2	7.63	7.37
3	8.86	8.40
4	10.20	9.55
5	11.61	10.81
6	13.06	12.15
7	14.54	13.54
8	16.04	14.96
9	17.55	16.42
10	19.08	17.89
20	34.68	33.30
30	50.54	49.13
40	66.50	65.10
50	82.51	81.14
60	98.54	97.20
70	114.60	113.29
80	130.67	129.40
90	146.75	145.49
100	162.84	161.61

Now we construct inverse Laplace transform with the TPPA. Let the original function be as follows:

$$f(t) = (1 + t^2)^{-0.5}. \tag{1.156}$$

Asymptotics of this function looks like

$$f(t) \cong \begin{cases} 1 - 0.5t^2 + \dots & \text{at } t \rightarrow 0, \\ t^{-1} + \dots & \text{at } t \rightarrow \infty. \end{cases}$$

TPPA in this case can be written as

$$f(t) = \frac{1 + 0.5t}{1 + 0.5t + 0.5t^2}. \tag{1.157}$$

Numerical results are shown in Figure 1.10. An approximate inversion (1.157) (upper curve) agrees well with the original (1.156) (lower curve) for all values of the argument.

Other examples on the effective use of the TPPA are reported in references [6], [75], [112], [258].

1.5.3 Other Methods of AEFs Construction

Unfortunately, the situations where both asymptotic limits have the form of power expansions are rarely encountered in practice, so we have to resort to other methods of AEFs constructing. Consider, for example, the following BVP

$$\epsilon y_{xx} - xy = \epsilon y, y(0) = 1, y(\infty) = 0, \epsilon \ll 1. \tag{1.158}$$

Solution for small values of x can be written as follows

$$y = 1 - a\xi + \frac{1}{6}\xi^3 + O(\xi^4), \tag{1.159}$$

where $\xi = x\epsilon^{-\frac{1}{3}}$, a is the arbitrary constant.

The solution for large values of x is constructed using the WKB method (see [62])

$$y = b\xi^{-\frac{1}{4}} \exp\left(-\frac{2}{3}\xi^{\frac{3}{2}}\right) \left[1 - \frac{5}{48}\xi^{-\frac{3}{2}} + O(\xi^{-3})\right], \tag{1.160}$$

where b is an arbitrary constant.

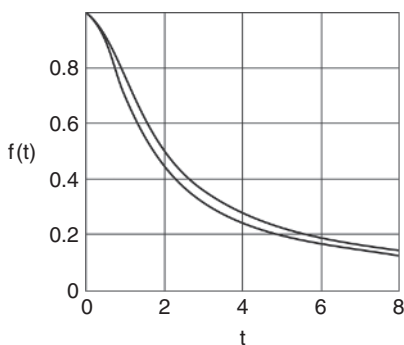

Figure 1.10 Exact and approximate Laplace transform inversions

Now we match these asymptotics. Because of the exponents occurred in Equation (1.160), using TPPA in the original form is not possible. Therefore, we construct AEF based on the following considerations: for large values of the variable ξ the exponent from Equation (1.160) is taken into account in its original form, and for small values of the variable ξ it is expanded in a Maclaurin series. Constructed in this way AEF has the form

$$y_a = \frac{1 - a\xi + \frac{2}{3}\xi^{\frac{3}{2}} - \frac{2}{3}\xi^{\frac{5}{2}} + \frac{32}{5}a\xi^4}{1 + \frac{32}{5}\frac{a}{b}\xi^{\frac{17}{4}}} \exp\left(-\frac{2}{3}\xi^{\frac{3}{2}}\right). \quad (1.161)$$

The coefficients a and b in Equation (1.161) still remain undefined. For calculation of these constants one can use some integral relations, for example, obtained from Equation (1.161) by multiplying them with the weighting functions $1, x, x^2, \dots$, and further integration over the interval $[0, \infty)$. In the end, such values of the constants are found

$$a = \frac{\sqrt[3]{3} \Gamma\left(\frac{2}{3}\right)}{\Gamma\left(\frac{2}{3}\right)}, \quad b = \frac{\sqrt[3]{9} \Gamma\left(\frac{2}{3}\right)}{2\sqrt{\pi}}. \quad (1.162)$$

Numerical calculations show that the formula (1.161) with constants (1.162) approximates the desired solution in the whole interval $[0, \infty)$ with an error not exceeding 1.5%.

When choosing the constants one can use other methods, in which case a lot depends on the skill of the researcher. Of course, it is necessary to ensure the correct qualitative behavior of AEFs, avoiding, for example zeros of the denominator, which do not correspond to the problem. To do this, one can vary the number of terms in the asymptotics and the numerator and denominator constructed uniformly suitable solutions. In general, the method of rational AEF can be described as follows [176]. Let us assume that function $f(z)$ has the following asymptotics:

$$f(z) = F(z) \text{ at } z \rightarrow \infty, \quad (1.163)$$

and

$$f(z) = \sum_{i=0}^{\infty} c_i z^i \text{ at } z \rightarrow 0. \quad (1.164)$$

Then the AEF can be produced from the Equations (1.165), (1.166) as follows

$$f(z) \approx \frac{\sum_{i=0}^m \alpha_i(z) z^i}{\sum_{i=0}^n \beta_i(z) z^i} \text{ at } z \rightarrow 0, \quad (1.165)$$

where α_i, β_i are considered not as constants but as some functions of z . Functions $\alpha_i(z)$ and $\beta_i(z)$ are chosen in such a way that:

1. The expansion of AEF (1.165) in powers of z for $z \rightarrow 0$ matches the PS (1.164);
2. The asymptotic behavior of AEF (1.165) for $z \rightarrow \infty$ coincides with the function $F(z)$ (1.163).

In the construction of AEFs a priori qualitative information is very important. For example, if from any considerations it is known that the unknown function is close to a power form, you can use the method of Sommerfeld [144]. Its essence is to replace a segment of the power series

$$f(x) = 1 + a_1x + a_2x^2 + \dots \quad (1.166)$$

by the function

$$f(x) \approx (1 + Ax)^\mu. \quad (1.167)$$

Expanding expression (1.167) in a MacLaurin series and comparing coefficients of this expansion with series (1.166), one obtains

$$A = \frac{a_1^2 - 2a_2}{a_1}; \mu = \frac{a_1^2}{a_1^2 - 2a_2}.$$

Numerical approaches also can be used for the construction of AEFs. For example, in reference [137] a computational technique for matching limiting asymptotics is described.

Sometimes it is possible to construct the so called composite equations, which can be treated as asymptotically equivalent equations. Let us emphasize, that the composite equations, due to [244], can be obtained in result of synthesis of the limiting cases. The principal idea of the method of the composite equations can be formulated in the following way [244]:

1. Identify the terms in the differential equations, whose neglect in the straightforward approximation is responsible for the nonuniformity.
2. Approximate those terms in so far as possible while retaining their essential character in the region of nonuniformity.

Let us dwell on the terminology. Here we use the term “asymptotically equivalent function”. Other terms “reduced method of matched asymptotic expansions” [144], “quasifractional approximants” [75], “mimic function” [113] are also used.

1.5.4 Example: Schrödinger Equation

For the Schrödinger equation (1.71) with BCs (1.72) we obtained previously a solution for the exponent, little different from the two (1.79). In [56] the following asymptotic solutions for $N \rightarrow \infty$ are obtained:

$$E_0(N) = \frac{\pi^2}{4} (2N)^{-\frac{2}{N+1}} \Gamma\left(\frac{N}{N+1}\right)^2. \quad (1.168)$$

Using Ansatzes (1.79) and (1.168), we construct AEF

$$E_0(N) \sim \frac{\pi + \Gamma\left(\frac{N}{N+1}\right)^2}{4(2N + \alpha)^{\frac{2}{N+1}}}, \quad (1.169)$$

where $\alpha = \pi^2 \Gamma(1.25) - 2 \approx 6.946$.

Numerical results are presented in Table 1.6. It is evident that formula (1.169) gives good results for all the values of N .

Table 1.6 Comparison of numerical and analytical results of the energy levels for the Schrödinger equation

N	E_0 ; numerical [56]	Equation (1.169)	Error, %
1	1.0000	1.0	0
2	1.0604	0.9974	5.9364
4	1.2258	1.17446	4.1882
10	1.5605	1.5398	1.33
50	1.1052	2.1035	0.079
200	2.3379	2.3376	0.006
500	2.4058	2.4058	≈ 0
1500	2.4431	2.4431	≈ 0
3500	2.4558	2.45558	≈ 0

1.5.5 Example: AEFs in the Theory of Composites

Now let us consider an application of the method of AEFs for the calculation of the effective heat conductivity of an infinite regular array of perfectly conducting spheres, embedded in a matrix with unit conductivity. The following expansion for the effective conductivity $\langle k \rangle$ has been reported in reference [215]

$$\langle k \rangle = 1 - \frac{3c}{-1 + c + a_1 c^{\frac{10}{3}} \frac{1+a_2 c^{\frac{11}{3}}}{1-a_3 c^{\frac{7}{3}}} + a_4 c^{\frac{14}{3}} + a_5 c^6 + a_6 c^{\frac{22}{3}} + O\left(c^{\frac{25}{3}}\right)}, \quad (1.170)$$

where c is the volume fraction of inclusions. Here we consider three types of space arrangement of spheres, namely, the simple cubic (SC), body centered cubic (BCC) and face centered cubic (FCC) arrays. The constants a_i for these arrays are given in Table 1.7.

In the case of perfectly conducting large spheres ($c \rightarrow c_{\max}$, where c_{\max} is the maximum volume fraction for a sphere) the problem can be solved by means of a reasonable physical assumption that the heat flux occurs entirely in the region, where spheres are in a near contact. Thus, the effective conductivity is determined in the asymptotic form for the flux between two spheres, which is logarithmically singular in the width of a gap, justifying the assumption [185]:

$$\langle k \rangle = -M_1 \ln \chi - M_2 + O(\chi^{-1}), \quad (1.171)$$

where $\chi = 1 - (c/c_{\max})^{\frac{1}{3}}$ is the dimensionless width of a gap between the neighboring spheres, $\chi \rightarrow 0$ for $c \rightarrow c_m$, $M_1 = 0.5c_{\max} p$, p is the number of contact points at the surface of a sphere;

Table 1.7 The constants a_1, \dots, a_6 in Equation (1.170)

	a_1	a_2	a_3	a_4	a_5	a_6
SC array	1.305	0.231	0.405	0.0723	0.153	0.0105
BCC array	0.129	-0.413	0.764	0.257	0.0113	0.00562
FCC array	0.0753	0.697	-0.741	0.0420	0.0231	$9.14 \cdot 10^{-7}$

Table 1.8 The constants M_1 , M_2 and c_{\max}

	M_1	M_2	c_{\max}
SC array	$\pi/2$	0.7	$\pi/6$
BCC array	$\sqrt{3}\pi/2$	2.4	$\sqrt{3}\pi/8$
FCC array	$0\sqrt{2}\pi$	7.1	$\sqrt{2}\pi/6$

M_2 is a constant, depending on the type of space arrangement of spheres. The values of M_1 , M_2 and c_{\max} for the three types of cubic arrays are given in Table 1.8.

On the basis of limiting solutions (1.170) and (1.171) we develop the AEF valid for all values of the volume fraction of inclusions $c \in [0, c_{\max}]$:

$$\langle k \rangle = \frac{P_1(c) + P_2 c^{\frac{m+1}{3}} + P_3 \ln \chi}{Q(c)}. \quad (1.172)$$

Here the functions $P_1(c)$, $Q(c)$ and the constants P_2 , P_3 are determined as follows:

$$Q(c) = 1 - c - a_1 c^{\frac{10}{3}}, \quad P_1(c) = \sum_{i=0}^m \alpha_i c^{\frac{i}{3}}, \quad P_2 = 0 \quad \text{for } n = 1,$$

$$P_2 = \frac{-[P_1(c_{\max}) + Q(c_{\max})M_2]}{c_{\max}^{\frac{m+1}{3}}} \quad \text{for } n = 2.$$

The AEF (1.172) takes into account leading terms of expansion (1.170) and leading terms of expansion (1.171), and the corresponding coefficients follow

$$\alpha_0 = 1, \quad \alpha_3 = 2 - \frac{Q(c_{\max})M_1}{3c_{\max}}, \quad \alpha_{10} = \alpha_1 - \frac{Q(c_{\max})M_1}{10c_{\max}^{\frac{10}{3}}},$$

$$\alpha_j = -\frac{Q(c_{\max})M_1}{j c_{\max}^{\frac{j}{3}}}, \quad j = 1, 2, \dots, m-1, m, \quad j \neq 3, 10.$$

The increment of m and n leads to the growth of the accuracy of the obtained solution (1.172). Let us illustrate this dependence in the case of SC array. We calculated $\langle k \rangle$ for different values of m and n . In Figure 1.11 our analytical results are compared with experimental measurements from [186] (black dots); details of these data can be found in [184]. Finally, we restrict $m = 19$ and $n = 2$ for all types of arrays, as they provide a satisfactory agreement with numerical data and a rather simple analytical form of the AEF (1.172).

Numerical results for the BCC and the FCC arrays are displayed in Figures 1.12 and 1.13, respectively. For BCC array the obtained AEF (1.172) is compared with the experimental results taken from [182] and [183]. For FCC array the experimental data are not available, therefore we are comparing with the numerical results obtained by [183] using the Rayleigh method. The agreement between the analytical solution (1.172) and the numerical results is quite satisfactory.

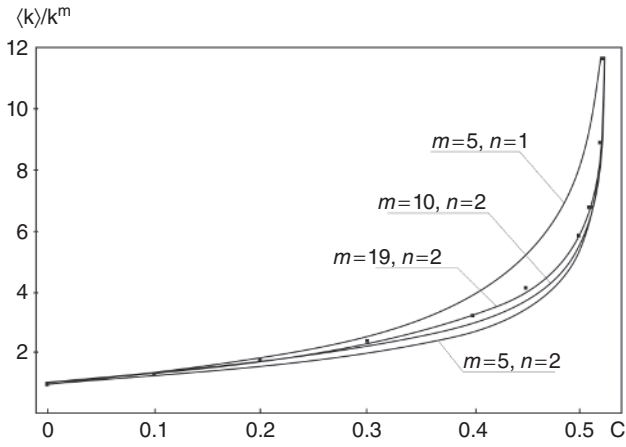

Figure 1.11 Effective conductivity $\langle k \rangle / k^m$ of the SC array vs. volume fraction of inclusions c

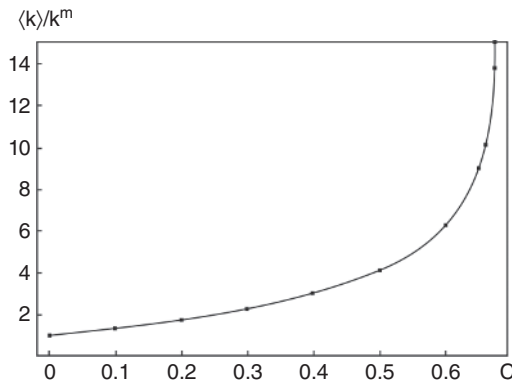

Figure 1.12 Effective conductivity $\langle k \rangle / k^m$ of the BCC array vs. volume fraction of inclusions c

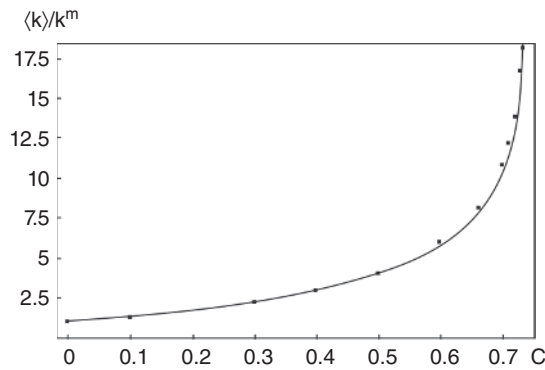

Figure 1.13 Effective conductivity $\langle k \rangle / k^m$ of the FCC array vs. volume fraction of inclusions c

1.6 Dynamical Edge Effect Method

1.6.1 Linear Vibrations of a Rod

We introduce the method of dynamical edge effect using a problem possessing an exact solution. We consider free vibrations of a rod of length L governed by the following PDE:

$$\frac{\partial^4 w}{\partial x^4} + a^2 \frac{\partial^2 w}{\partial t^2} = 0, \quad a^2 = \frac{\rho F}{EI}. \quad (1.173)$$

Consider two variants of the boundary conditions:

a) simple support

$$\text{for } x = 0, L \quad w = 0, \quad \frac{\partial^2 w}{\partial x^2} = 0; \quad (1.174)$$

b) rigid clamping

$$\text{for } x = 0, L \quad w = 0, \quad \frac{\partial w}{\partial x} = 0. \quad (1.175)$$

Since we consider natural vibrations, the process of looking for function $w(x, t)$ is assumed in the following form

$$w(x, t) = W(x) \exp(i\omega t).$$

The eigenfunction $W(x)$ is yielded by the following equation

$$\frac{d^4 W}{dx^4} - a^2 \omega^2 W = 0. \quad (1.176)$$

Observe that for $\omega^2 \rightarrow \infty$ Equation (1.176) is reduced to trivial one, therefore an application of the boundary functions or of the matched asymptotic series does not belong to easy tasks.

A solution to Equation (1.176) with BCs (1.174) follows

$$W_m = \sin\left(\frac{m\pi}{L}x\right), \quad m = 1, 2, 3, \dots; \quad (1.177)$$

$$\omega_m = \frac{1}{a} \left(\frac{m\pi}{L}\right)^2. \quad (1.178)$$

One may verify that the BVP (1.175), (1.176) does not allow us to obtain the solution (1.177). However, if an eigenfunction rapidly oscillates with respect to x , i.e. we consider a sufficiently high order vibration form, then we may expect that in this case a solution (1.177) holds for an internal region located far from the boundaries (Figure 1.14). Even though the boundary conditions are not satisfied, we may try to construct a solution compensating the occurred errors on the BC and being rapidly decaying while approaching the internal region, and hence the approximating formulas for eigenfunctions and frequencies can be derived.

We assume the following solution to Equation (1.176):

$$W_0 = \sin \frac{\pi(x - x_0)}{\lambda}, \quad (1.179)$$

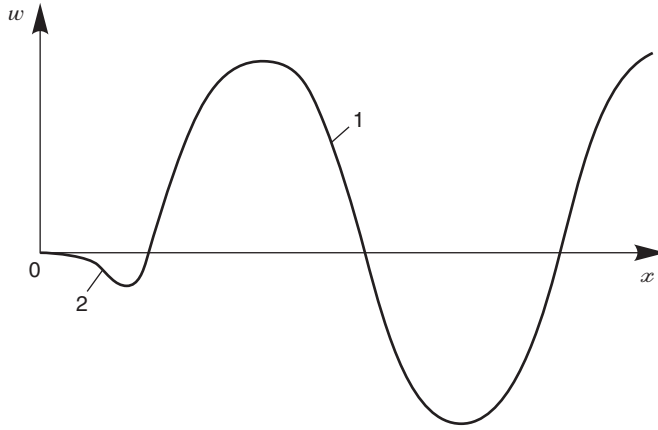

Figure 1.14 Curve 1 depicts the rapidly oscillating state, whereas curve 2 presents a sum of the fundamental state and dynamical edge effect

where x_0 , λ correspond to shift and length of the wave, respectively. Values of x_0 and λ will be estimated in the process of construction of the dynamical edge effect.

Vibration frequency

$$\omega = \frac{1}{a} \left(\frac{\pi}{\lambda} \right)^2. \quad (1.180)$$

Let us present Equation (1.176) in the following way [240]:

$$\left(\frac{d^2}{dx^2} + a\omega \right) \left(\frac{d^2}{dx^2} - a\omega \right) W = 0. \quad (1.181)$$

Therefore, its general solution has the following form

$$W = W_1 + W_2,$$

where functions W_1 and W_2 are general solutions of the equations

$$\frac{d^2 W_1}{dx^2} + a\omega W_1 = 0, \quad (1.182)$$

$$\frac{d^2 W_2}{dx^2} - a\omega W_2 = 0. \quad (1.183)$$

When the eigenforms change rapidly ($a\omega \gg 1$), the following estimations hold

$$\frac{dW_1}{dx} \sim a\omega W_1, \quad \frac{dW_2}{dx} \sim a\omega W_2.$$

Observe that W_1 represents rapidly oscillating function, whereas W_2 presents a sum of exponential functions with large exponents. Hence, here we deal rather with untypical situation, since we do not have small and large real values of the routes of the characteristic equation, which correspond to slow and fast changeable solution components. We deal here with splitting of two states, where one of them rapidly oscillates and the second is concentrated near

the boundaries. In other words the characteristic equation has real and imaginary roots of the same moduli order.

In what follows we construct the edge effect described by Equation (1.183). Taking into account Equation (1.180), the following relations for the edge effects located in neighborhood of the edges $x = 0$ and $x = L$ are obtained:

$$\begin{aligned} W_{1cr} &= C_1 \exp(-\pi \lambda^{-1} x), \\ W_{2cr} &= C_2 \exp[-\pi \lambda^{-1} (x - L)]. \end{aligned} \quad (1.184)$$

In order to define the eigenform and the associated frequency we need to find x_0 , λ and arbitrary constants C_1 , C_2 from the boundary conditions:

$$\text{for } x = 0 \quad W_0 + W_{1cr} = 0, \quad \frac{d}{dx}(W_0 + W_{1cr}) = 0; \quad (1.185)$$

$$\text{for } x = L \quad W_0 + W_{2cr} = 0, \quad \frac{d}{dx}(W_0 + W_{2cr}) = 0. \quad (1.186)$$

Substituting Equations (1.179) and (1.184) into Equation (1.185) and (1.186) one gets

$$C_1 - \sin \frac{\pi x_0}{\lambda} = 0, \quad C_1 - \cos \frac{\pi x_0}{\lambda} = 0, \quad (1.187)$$

$$C_2 + \sin \left(\pi \frac{L - x_0}{\lambda} \right) = 0, \quad C_2 + \cos \left(\pi \frac{L - x_0}{\lambda} \right) = 0. \quad (1.188)$$

Furthermore, we obtain

$$\lambda = \frac{L}{m + 0,5}, \quad m = 1, 2, \dots; \quad x_0 = \lambda(0,25 + n), \quad n = 1, 2, \dots$$

Finally, the formula for eigenfrequencies of a clamped rod is as follows:

$$\omega_m = \pi^2 \frac{(m + 0,5)^2}{aL^2}, \quad m = 1, 2, \dots \quad (1.189)$$

Formula (1.189) for fundamental frequency gives the error of 1%.

The method described so far has been proposed by Bolotin [58], [59]. On the other hand, Keller and Rubinow [28], [146] have proposed the wave method for the Laplace equation. The latter one has been generalized into biharmonic equation [76], and next the equivalence of both Bolin's and Keller-Rubinow methods have been proved [77], [78].

1.6.2 Nonlinear Vibrations of a Rod

In order to present the main ideas of this method for a nonlinear case, we use the Kirchhoff equation:

$$EI \frac{\partial^4 w}{\partial x^4} - \frac{EF}{2L} \left[\int_0^L \left(\frac{\partial w}{\partial x} \right)^2 dx \right] \frac{\partial^2 w}{\partial x^2} + \rho F \frac{\partial^2 w}{\partial t^2} = 0. \quad (1.190)$$

Let the rod be elastically clamped, hence we have

$$\text{for } x = 0, L \quad w = 0, \quad \frac{\partial^2 w}{\partial x^2} - c^* \frac{\partial w}{\partial x} = 0, \quad (1.191)$$

where $c^* = c/(EI)$, and c is the coefficient of clamping.

Zero order solution is approximated by the following form

$$w_0 = A \sin \frac{\pi(x - x_0)}{\lambda} \xi(t). \quad (1.192)$$

Substituting Equation (1.192) into Equation (1.190) we get

$$\frac{d^2 \xi}{dt^2} + \omega^2(1 + \gamma \xi^2) \xi = 0, \quad (1.193)$$

where

$$\omega^2 = EI\rho^{-1} \left(\frac{\pi}{\lambda} \right)^2, \quad \gamma = 0, 25(1 + \lambda_1) \left(\frac{A}{r} \right)^2,$$

$$r = \sqrt{I/F}, \quad \lambda_1 = \frac{\lambda}{2\pi L} \left[\sin \frac{2\pi(L - x_0)}{\lambda} + \sin \frac{2\pi x_0}{\lambda} \right].$$

Equation (1.193) with the initial condition

$$\xi(0) = 1, \quad \frac{d\xi(0)}{dt} = 0 \quad (1.194)$$

has the following solution

$$\xi(t) = \text{cn}(\sigma t, k), \quad \sigma = \omega \sqrt{1 + \gamma}, \quad (1.195)$$

where $\text{cn}(\dots, \dots)$ denotes Jacoby's cosine function of period T equal to $4K$; $K = \int_0^{\pi/2} (1 - k^2 \sin^2 \varphi)^{-0.5} d\varphi$ is the full elliptic integral of the first kind with the modulus $k = \sqrt{0, 5\gamma/(1 + \gamma)}$ ([2], chapter 16).

The solution of our problem far from edges is

$$w_0 = W_0(x) \text{cn}(\sigma t, k), \quad (1.196)$$

where $W_0(x) = A \sin(\pi(x - x_0))/\lambda$.

Solution (1.196) satisfies Equation (1.190) but it does not satisfy the BCs (1.191). In order to construct states localized in the vicinity of edges, we assume the following solution

$$w = w_0 + w_{cr}. \quad (1.197)$$

Substituting Equation (1.197) into Equation (1.190) yields

$$\frac{\partial^4}{\partial x^4} (w_0 + w_{cr}) - 0, 5(r^2 L)^{-1} \frac{\partial^2}{\partial x^2} (w_0 + w_{cr}) \int_0^L \left(\frac{\partial w_0}{\partial x} + \frac{\partial w_{cr}}{\partial x} \right)^2 dx$$

$$+ \frac{\rho}{EI} \frac{\partial^2}{\partial t^2} (w_0 + w_{cr}) = 0. \quad (1.198)$$

Observe that contrary to the earlier studied linear case, now functions w_0 and w_{cr} are coupled due to nonlinearity of the problem. On the other hand, the fundamental state as well as the edge effects differ strongly from the point of view of energy, since the latter one is localized in a boundary layer of the rod edges [15]. In what follows we are going to estimate orders of underintegral terms in Equation (1.198) with respect to $L/\lambda \gg 1$:

$$\int_0^L \left(\frac{\partial w_0}{\partial x} \right)^2 dx \sim \left(\frac{L}{\lambda} \right)^2; \quad \int_0^L \frac{\partial w_0}{\partial x} \frac{\partial w_{cr}}{\partial x} dx \sim \frac{L}{\lambda};$$

$$\int_0^L \left(\frac{\partial w_{cr}}{\partial x} \right)^2 dx \sim 1. \quad (1.199)$$

Taking into account only the term $(\pi/\lambda)^2$ in the first approximation in Equation (1.198), the latter equation is recast to the following form

$$\frac{\partial^4 w_0}{\partial x^4} - 0,5(r^2 L)^{-1} \frac{\partial^2 w_0}{\partial x^2} \int_0^L \left(\frac{\partial w_0}{\partial x} \right)^2 dx + \frac{\rho}{EI} \frac{\partial^2 w_0}{\partial t^2}$$

$$+ \frac{\partial^4 w_{cr}}{\partial x^4} - 0,5(r^2 L)^{-1} \frac{\partial^2 w_{cr}}{\partial x^2} \int_0^L \left(\frac{\partial w_0}{\partial x} \right)^2 dx + \frac{\rho}{EI} \frac{\partial^2 w_{cr}}{\partial t^2} = 0. \quad (1.200)$$

Substituting Equation (1.196) into Equation (1.200) yields the following equation

$$\frac{\partial^4 w_{cr}}{\partial x^4} - B \text{cn}^2(\sigma t, k) \frac{\partial^2 w_{cr}}{\partial x^2} + \frac{\rho}{EI} \frac{\partial^2 w_{cr}}{\partial t^2} = 0, \quad (1.201)$$

where $B = \gamma \left(\frac{\pi}{\lambda} \right)^2$.

Note that although we deal with the linear equation (1.201) but with time dependent coefficients. Since we cannot separate time and space dependent variables, we apply here Kantorovitch method [142]. Namely, we introduce the following approximation

$$w_{cr}(x, t) \cong W_{cr}(x) \text{cn}(\sigma t, k). \quad (1.202)$$

Substituting Equation (1.202) into Equation (1.201) and reducing time the following ODE is obtained

$$\frac{d^4 W_{cr}}{dx^4} - B_1 \frac{d^2 W_{cr}}{dx^2} - \left(\frac{\pi}{\lambda} \right)^2 \left[\left(\frac{\pi}{\lambda} \right)^2 + B_1 \right] W_{cr} = 0, \quad (1.203)$$

where

$$B_1 = A \left(\frac{2k^2 - 1}{2k^2} + \frac{\sqrt{1 - k^2}}{2k \arcsin k} \right). \quad (1.204)$$

In relation (1.203) and further $\arcsin(\dots)$ is understood in the sense of its main value.

The characteristic equation of (1.203) has four roots, and two purely imaginary roots can be omitted here (they correspond to zero order solution). Real roots correspond to the following solution

$$W_{cr}(x) = C_1 \exp \left[-\sqrt{\left(\frac{\pi}{\lambda} \right)^2 + B_1} x \right] + C_2 \exp \left[\sqrt{\left(\frac{\pi}{\lambda} \right)^2 + B_1} x \right].$$

If the interaction of the rod edges can be neglected, then the condition of decaying of the boundary effect implies $C_2 = 0$ yielded by $x \rightarrow \infty$.

Satisfying the BC for $x = 0$ yields

$$W_0 + W_{cr} = 0, \quad \frac{d^2 W_0}{dx^2} + \frac{d^2 W_{cr}}{dx^2} = c^* \left(\frac{dW_0}{dx} + \frac{dW_{cr}}{dx} \right),$$

which allows to find the constant C_1 :

$$C_1 = A \sin \frac{\pi x_0}{\lambda},$$

$$x_0 = \frac{\lambda}{\pi} \arctan \frac{\pi}{\lambda \left[(2(\pi/\lambda)^2 + B_1) / c^* + \sqrt{(\pi/\lambda)^2 + B_1} \right]}. \quad (1.205)$$

Note that for $c^* \rightarrow 0$ and $c^* \rightarrow \infty$ formulas (1.204) yield also solution to the limiting cases of both simply supported and clamped rod edges.

Proceeding in the analogous way one may also construct the dynamics edge effect localized in the vicinity of $x = L$.

Forms of nonlinear rod vibrations can be separated into two groups with respect a symmetry type. In the case of symmetry regarding the point $x = L/2$, the condition

$$\frac{dW_0}{dx} = 0 \quad \text{for } x = L/2$$

implies

$$L - 2x_0 = (2m + 1)\pi, \quad m = 1, 2, \dots \quad (1.206)$$

In the case of antisymmetric forms, the condition

$$W_0 = 0 \quad \text{for } x = L/2$$

yields

$$L - 2x_0 = 2n\pi, \quad n = 1, 2, \dots \quad (1.207)$$

Equations (1.206), (1.207) are reduced to the following one

$$L - 2x_0 = m\pi, \quad m = 1, 2, \dots, \quad (1.208)$$

where odd (even) m values correspond to symmetric (antisymmetric) forms with respect to the point $x = L/2$.

Therefore, constants λ and x_0 are defined via Equations (1.204), (1.205) and (1.208).

1.6.3 Nonlinear Vibrations of a Rectangular Plate

We begin with Berger dynamic equation [76],[48]

$$D\nabla^4 w - T\nabla^2 w + \rho h \frac{\partial^2}{\partial t^2} w = 0, \quad (1.209)$$

$$Th^2 ab = 6D \int_0^b \int_0^a \left[\left(\frac{\partial w}{\partial x} \right)^2 + \left(\frac{\partial w}{\partial y} \right)^2 \right] dx dy. \quad (1.210)$$

Let the plate be rigidly clamped along its contour

$$\text{for } x = 0, a \quad w = \frac{\partial w}{\partial x} = 0, \quad (1.211)$$

$$\text{for } y = 0, b \quad w = \frac{\partial w}{\partial y} = 0. \quad (1.212)$$

The plate deflection follows

$$w_0(x, y, t) = A \sin k_1(x - x_1) \sin k_2(y - y_1) \xi(t), \quad (1.213)$$

where k_i, x_1, y_1 are constant quantities to be defined.

Substituting Ansatz (1.213) into Equations (1.209), (1.210) and reducing the space variables we obtain Equation (1.193) regarding time-dependent function $\xi(t)$ with the following coefficients

$$\begin{aligned} \omega^2 &= D(\rho h)^{-1}(k_1^2 + k_2^2)^2, \\ \gamma &= 1, 5 \left(\frac{A}{h} \right)^2 \frac{k_1^2(a_1 + \lambda_1)(a_2 - \lambda_2) + k_2^2(a_1 - \lambda_1)(a_2 + \lambda_2)}{a_1 a_2 (k_1^2 + k_2^2)}, \\ \lambda_1 &= 0, 5 k_1^{-1} [\sin 2k_1(x - x_1)]|_0^a, \lambda_2 = 0, 5 k_2^{-1} [\sin 2k_2(y - y_1)]|_0^b. \end{aligned}$$

A solution to this time-dependent equation takes the form (1.195) for initial conditions (1.194).

Therefore, the following zero order solution is found

$$w_0 = A \sin k_1(x - x_1) \sin k_2(y - y_1) \text{cn}(\sigma t, k), \quad (1.214)$$

being valid in the internal plate part located sufficiently far from the plate boundaries.

Let us now proceed to construction of dynamic edge effects localized in vicinity of the plate contour. Substituting w in the form of (1.197) into Equations (1.209), (1.210) yields

$$D \nabla^4 (w_0 + w_{cr}) - T \nabla^2 (w_0 + w_{cr}) + \rho h \frac{\partial^2}{\partial t^2} (w_0 + w_{cr}) = 0, \quad (1.215)$$

$$Th^2 ab = 6D \int_0^b \int_0^a \left[\left(\frac{\partial (w_0 + w_{cr})}{\partial x} \right)^2 + \left(\frac{\partial (w_0 + w_{cr})}{\partial y} \right)^2 \right] dx dy. \quad (1.216)$$

Let us apply further the energy approach used in the case of a study of nonlinear vibrations of the rod. We estimate an order of the quantities standing on the r.h.s. of Equation (1.216) with respect to nondimensional parameters $ak_1 \sim bk_2 \gg 1$. The following relations hold:

$$\begin{aligned} \int_0^b \int_0^a \left(\frac{\partial w_0}{\partial x} \right)^2 dx dy &\sim a^2 k_1^2, & \int_0^b \int_0^a \left(\frac{\partial w_0}{\partial y} \right)^2 dx dy &\sim b^2 k_2^2, \\ \int_0^b \int_0^a \frac{\partial w_0}{\partial x} \frac{\partial w_{cr}}{\partial x} dx dy &\sim ak_1, & \int_0^b \int_0^a \frac{\partial w_0}{\partial y} \frac{\partial w_{cr}}{\partial y} dx dy &\sim bk_2, \\ \int_0^b \int_0^a \left(\frac{\partial w_{cr}}{\partial x} \right)^2 dx dy &\sim 1, & \int_0^b \int_0^a \left(\frac{\partial w_{cr}}{\partial y} \right)^2 dx dy &\sim 1. \end{aligned} \quad (1.217)$$

The given estimations imply that in relation (1.216) one may keep the solution components of order $a^2 k_1^2 \sim b^2 k_2^2 \gg 1$. In the first approximation, which depends only on the fundamental state, Equations (1.215), (1.216) are cast to the following form:

$$\nabla^4 w_{cr} - B \text{cn}^2(\sigma t, k) \nabla^2 w_{cr} + \rho h D^{-1} \frac{\partial^2 w_{cr}}{\partial t^2} = 0, \quad (1.218)$$

where $B = \gamma(k_1^2 + k_2^2)$.

The linear PDE (1.218) with time-dependent coefficients serves for construction of four dynamic edge effects regarding the plate edges $x = 0, a$ and $y = 0, b$. We assume again that the plate sides possess sufficient length that their interaction can be neglected.

Let us consider an edge effect localized in vicinity of the edge $x = 0$ (the remaining cases can be solved in a similar way). We take

$$w_{cr}(x, y, t) = \Phi(x, t) \sin k_2(y - y_1),$$

and we obtain the following PDE

$$\frac{\partial^4 \Phi}{\partial x^4} - [B \operatorname{cn}^2(\sigma t, k) + 2k_2^2] \frac{\partial^2 \Phi}{\partial x^2} + k_2^2 [B \operatorname{cn}^2(\sigma t, k) + 2k_2^2] \Phi + \rho h D^{-1} \frac{\partial^2 \Phi}{\partial t^2} = 0. \quad (1.219)$$

We apply Kantorovitch approach by assuming

$$\Phi(x, t) \cong \varphi(x) \operatorname{cn}(\sigma t, k).$$

Then, Equation (1.219) yields

$$\frac{d^4 \varphi}{dx^4} - (B_1 + 2k_2^2) \frac{d^2 \varphi}{dx^2} + [k_2^2(B_1 + 2k_2^2) - (k_1^2 + k_2^2)(B_1 + k_1^2 + k_2^2)] \varphi = 0. \quad (1.220)$$

where

$$B_1 = B \left[\frac{2k^2 - 1}{2k^2} + \frac{\sqrt{1 - k^2}}{2k \operatorname{arcsin} k} \right].$$

Equation (1.220) is recast in the following equivalent form

$$\left(\frac{d^2}{dx^2} + k_1^2 \right) \left(\frac{d^2}{dx^2} - k_1^2 - 2k_2^2 - B_1 \right) \varphi = 0.$$

We neglect the first multiplier describing the fundamental state, and the second equation has a solution associated with the edge effect

$$\varphi(x) = C_1 \exp \left(-\sqrt{k_1^2 + 2k_2^2 + B_1} x \right) + C_2 \exp \left(\sqrt{k_1^2 + 2k_2^2 + B_1} x \right).$$

Finally, the edge effect in the neighborhood of the plate edge $x = 0$ can be written in the following form

$$w_{cr}^{(1)} = \left[C_1 \exp \left(-\sqrt{k_1^2 + 2k_2^2 + B_1} x \right) + C_2 \exp \left(\sqrt{k_1^2 + 2k_2^2 + B_1} x \right) \right] \sin k_2(y - y_1) \operatorname{cn}(\sigma t, k). \quad (1.221)$$

Proceeding in analogous way, the edge effect in vicinity of the plate edge $y = 0$ is governed by the following function

$$w_{cr}^{(2)} = \left[C_3 \exp \left(-\sqrt{k_1^2 + 2k_2^2 + B_1} y \right) + C_4 \exp \left(\sqrt{k_1^2 + 2k_2^2 + B_1} y \right) \right] \sin k_1(x - x_1) \operatorname{cn}(\sigma t, k). \quad (1.222)$$

We express BCs (1.211), (1.212), taking into account Equation (1.197), in the following form:

$$\text{for } x = 0 \quad w_0 + w_{cr}^{(1)} = 0, \quad \frac{\partial}{\partial x} (w_0 + w_{cr}^{(1)}) = 0; \quad (1.223)$$

$$\text{for } y = 0 \quad w_0 + w_{cr}^{(2)} = 0, \quad \frac{\partial}{\partial y} (w_0 + w_{cr}^{(2)}) = 0. \quad (1.224)$$

Conditions of decaying of the edge effects follow:

$$\text{for } x \rightarrow \infty \quad w_{cr}^{(1)} \rightarrow 0, \quad (1.225)$$

$$\text{for } y \rightarrow \infty \quad w_{cr}^{(2)} \rightarrow 0. \quad (1.226)$$

Then satisfaction of Equations (1.225), (1.226) implies $C_2 = C_4 = 0$, and next from Equations (1.223), (1.224) we get:

$$x_1 = k_1^{-1} \arctan \left[k_1 (k_1^2 + 2k_2^2 + B_1)^{-1/2} \right], \quad (1.227)$$

$$C_1 = fk_1 [2(k_1^2 + k_2^2) + B_1]^{-1/2};$$

$$y_1 = k_2^{-1} \arctan \left[k_2 (k_1^2 + 2k_2^2 + B_1)^{-1/2} \right], \quad (1.228)$$

$$C_3 = fk_2 [2(k_1^2 + k_2^2) + B_1]^{-1/2}.$$

Let us split forms of plate vibrations into two groups with respect to a symmetry type regarding the lines $x = 0, 5a$, $y = 0, 5b$. In the case of symmetric form in both directions we have

$$\frac{\partial w_0}{\partial x} = 0 \quad \text{for } x = a/2, \quad \frac{\partial w_0}{\partial y} = 0 \quad \text{for } y = b/2.$$

which implies

$$k_1(a - 2x_1) = (2m + 1)\pi, \quad (1.229)$$

$$k_2(b - 2y_1) = (2n + 1)\pi, \quad m, n = 1, 2, \dots \quad (1.230)$$

Analogously, in the case of an antisymmetric form in both directions we have

$$w_0 = 0 \quad \text{for } x = a/2, \quad w_0 = 0 \quad \text{for } y = b/2.$$

Relations (1.229), (1.230) yield

$$k_1(a - 2x_1) = 2p\pi, \quad (1.231)$$

$$k_2(b - 2y_1) = 2q\pi, \quad p, q = 1, 2, \dots \quad (1.232)$$

Equations (1.229), (1.231) and (1.230), (1.234) can be cast into the following relations

$$k_1(a - 2x_1) = m\pi, \quad (1.233)$$

$$k_2(b - 2y_1) = n\pi, \quad m, n = 1, 2, \dots \quad (1.234)$$

It means that one may get all possible vibration forms through proper choice of m and n .

1.6.4 Matching of Asymptotic and Variational Approaches

Asymptotic method of dynamical edge effect is generally devoted to determination of high frequencies and associated forms, but it yields also correct results for low frequency spectrum assuming that we deal with the kinematic boundary conditions. However, in the static problems the accuracy of low frequencies estimation in the object contour decreases. Application of the method described so far to estimate first fundamental frequency does not yield satisfactory results.

However, there exists a prospective direction to increase the efficiency of the dynamical edge effect method through matching it with one of the energetic approaches. The latter approaches allow us not only to improve the accuracy of the results obtained, but also to extend its area of application.

Let us consider the eigenvalue problem of a square ($0 \leq x, y \leq a$) of a plate simply supported along its contour. The governing equation is obtained from Equation (1.209) putting $N = 0$. The BCs have the following form:

$$w_{xx} + \nu w_{yy} = 0, \quad w_{xxx} - 2(1 - \nu)w_{xyy} = 0 \quad \text{for } x = 0, a; \quad (1.235)$$

$$w_{yy} + \nu w_{xx} = 0, \quad w_{yyy} - 2(1 - \nu)w_{yxx} = 0 \quad \text{for } y = 0, a. \quad (1.236)$$

In order to estimate the eigenfrequency the Rayleigh-Ritz method is applied [47], which uses the principle of virtual displacements. According to this principle, the work of internal and external forces acting on the plate on its virtual displacements is equal zero, which means that

$$U + V + R = 0. \quad (1.237)$$

Potential (U) and kinetic (V) energies of the plate are as follows

$$U = \frac{D}{2} \int_0^a \int_0^a (w_{xx}^2 + w_{yy}^2 + 2\nu w_{xx}^2 w_{yy}^2 + 2(1 - \nu)w_{xy}^2) dx dy, \quad (1.238)$$

$$V = \frac{1}{2} \int_0^a \int_0^a \rho h w_t^2 dx dy. \quad (1.239)$$

In this case, the work of external forces R is equal zero. Assuming the plate deflection in the following form

$$w(x, y, t) = W(x, y) \exp(i\omega t),$$

Equation (1.237) yields the plate frequency

$$\lambda^2 = \omega^2 a^4 \frac{\rho h}{D} = a^4 \left[\int_0^a \int_0^a (W_{xx}^2 + W_{yy}^2 + 2\nu W_{xx}^2 W_{yy}^2 + 2(1 - \nu)W_{xy}^2) dx dy \right] \times \left[\int_0^a \int_0^a W^2 dx dy \right]^{-1}. \quad (1.240)$$

Application of the dynamical edge effect method yields the following formula governing the plate deflection

$$W(x, y) = W_0(x, y) + W_1(x) \sin(\beta_2 y + l_2) + W_2(y) \sin(\beta_1 x + l_1),$$

where

$$W_0(x) = \sin(\beta_1 x + l_1) \sin(\beta_2 + l_2), \quad (1.241)$$

$$W_1(x) = C_{11} \exp[\alpha_1(x - a)] + C_{12} \exp(-\alpha_1 x),$$

$$W_2(x) = C_{21} \exp[\alpha_2(y - a)] + C_{22} \exp(-\alpha_2 y). \quad (1.242)$$

Taking into account the boundary conditions, wave numbers are defined through the following system of transcendental equations:

$$\beta_i a = 2l_i + m\pi, \quad i = 1, 2, \quad m = 0, 1, 2, \dots, \quad (1.243)$$

where

$$l_i = \arctan \left[\frac{\beta_i}{\alpha_i} \left(\frac{\beta_i^2 + (2 - \nu)\beta_k^2}{\beta_i^2 + \nu\beta_k^2} \right)^2 \right],$$

$$\alpha_i = (\beta_i^2 + 2\beta_k^2)^{1/2}, \quad i = 1, 2, \quad k = 1, 2, i \neq k.$$

constants C_{ij} in Equation (1.242) are defined as follows

$$C_{i1} = \frac{\alpha_i^2 \sin l_i}{\alpha_i^2 - \nu\beta_k^2}, \quad C_{i2} = \frac{\alpha_i^2 \sin(\beta_i a + l_i)}{\alpha_i^2 - \nu\beta_k^2}, \quad i = 1, 2, \quad k = 1, 2, \quad i \neq k. \quad (1.244)$$

Formula (1.240), taking into account Equations (1.241)–(1.244), allows to define the plate frequency.

In Table 1.9 a comparison of the obtained nondimensional frequency λ of the square plate being free along its contour for $\nu = 0.225$ is reported (Rayleigh-Bolotin method (MRB) with values obtained by Rayleigh-Ritz [121] as well as the traditional Bolotin asymptotic method (AMB) are applied). We do not consider vibrations with respect to the cylindrical surface, since in the latter case one may get the exact solution. This is why numbers corresponding to the associated vibration forms are omitted in Table 1.9.

Results obtained via MRR of higher order approximations have the high order of accuracy in the interval of lower eigenfrequencies. However, increasing the number of a vibration form implies decrease of the obtained accuracy. Comparison of data obtained via different methods shows that error of first frequency estimation through MRB (2.7%) is essentially less than that using the traditional method of dynamical effect (13.6%). Increasing vibration form number

Table 1.9

Number of vibrations	λ , MRR[121]	λ , MRB	Error, %	λ , AMB	Error, %
1	14, 10	14, 48	2, 7	12, 41	13, 6
3	35, 96	36, 68	2, 0	34, 60	3, 9
5	65, 24	66, 33	1, 7	63, 44	2, 8
6	74, 45	75, 28	1, 1	73, 59	2, 5
7	109, 30	109, 10	0, 2	106, 30	2, 8

both asymptotic solutions approach the exact value (MRB yield upper, whereas edge effect lower bands estimation).

Consider now the problem of stability of a square clamped isotropic plate subjected to action of uniformly distributed compressing load N_0 applied to the middle plate surface. BCs are governed by (1.211), (1.212) ($b = a$), and in Equation (1.209) one needs to substitute T by $-T_0$. We apply MRB in order to find the critical compressing load. In this case the kinetic energy of the plate equals zero, whereas the work of active forces follows

$$R = -\frac{T_0}{2} \int_0^a \int_0^a (w_x^2 + w_y^2) dx dy.$$

Equation (1.237) yields the following nondimensional critical value of the force

$$P = \left(\frac{a}{\pi}\right)^2 \left[\int_0^a \int_0^a (w_{xx}^2 + 2w_{xx}w_{yy}^2 + w_{yy}^2) dx dy \right] \left[\int_0^a \int_0^a (w_x^2 + w_y^2) dx dy \right]^{-1}, \quad (1.245)$$

where $P = T_0 a^2 / (D\pi^2)$.

A solution to the problem is taken in the form of (1.241). Due to the symmetry of the problem, the wave numbers are detected from the following equation

$$\beta a = 2 \arctan [\operatorname{th}(0, 5\beta a)] + \pi.$$

The constants l_i, C_i are defined as follows

$$l_i = 0, 5(\pi - \beta a), \quad C_{i1} = C_{i2} = -\cos(0.5\beta a) / \operatorname{ch}(0.5\beta a), \quad i = 1, 2.$$

This found solution is substituted into Equation (1.245), and then P is defined. The critical compressing force obtained via MRR [253] is $P = 5, 31$. The computational error associated with the AMB (MRB) application reaches the value of 18% (8%).

The approach described so far also allows us to apply the method of dynamical edge effect for plates of either complicated forms (rectangular, circle [17], [18]) or design (for instance ribbed plates [16]).

1.6.5 On the Normal Forms of Nonlinear Vibrations of Continuous Systems

It is known that while investigating linear vibrations of discrete systems with finite number of degrees of freedom a key role is played by normal vibrations. Kauderer [141] has shown that also in a nonlinear system there exist solutions playing a similar role to that exhibited by normal vibrations of linear systems. He called them main vibrations and proposed a way of constructing their trajectories in a configuration state. Rosenberg [213], in order to define normal forms of vibrations of nonlinear systems with a finite degrees of freedom, formulated the problem in the configuration space in an approximate way and succeeded in finding a few classes of nonlinear systems having solutions exhibited by lines trajectories (see [168], [171], [170], [239]). Attempts to generalize the introduced concepts into continuous systems are associated with separation of finite and space variables ([57], [171], [225]), i.e. they rely on the possibility of the following representation

$$U(\mathbf{x}, t) = X(\mathbf{x})T(t).$$

It is clear that the latter approach can be validated only for some boundary conditions. Applying a concept of the dynamical edge effect one may introduce the following definition. We say that a function $U(x, t)$ is called a normal form of nonlinear vibration of a continuous system if

$$U(\mathbf{x}, t) = X(\mathbf{x})T(t) + Y(\mathbf{x}, t),$$

where $T(t)$ stands for a periodic function, $Y(\mathbf{x}, t)$ is a quasi-periodic function, and $Y(\mathbf{x}, t)$ is small in comparison to $X(\mathbf{x})T(t)$ in a certain energetic norm. The latter condition can be either verified by a priori or posteriori approach.

1.7 Continualization

1.7.1 Discrete and Continuum Models in Mechanics

In mechanics of continuum media we deal with continuous objects described by continuous functions. Although this is reliable, it is a common article of faith that somehow the average of the microsystems is exactly described by the equations of fluid mechanics, but no one has proved this for a *realistic* model of the fine structure: the best proofs are for idealized models of a rarefied monatomic gas ([208] p. 217). A transition from a real discrete nature to its continuum model requires the introduction of a certain averaging. On the other hand, the key factors of the theory of elasticity, stress, strain and the rest are formally *defined* as limits, by considering arbitrarily small parts of the body, but are only *meaningful* as representing average behavior over regions that are large in comparison to atoms ([208], p. 286). The usually applied methods of averaging and homogenization are described in chapter 6. Since continualization of discrete relations has its own peculiarities, we have decided to illustrate them in this chapter. It is appropriate to introduce the reader to this matter using relatively simple examples, since the construction of mechanics of a continuum medium using only “first principles” and applied so far only to molecular theory belongs to more difficult branches of physics [260], [150], [152].

The average approach works reasonably well for the determination of global characteristics. As has been pointed out by Ulam ([236], p. 89, 90), the simplest problems involving an actual infinity of particles in distribution of matter already appear in classical mechanics. A discussion on these will permit us to introduce more general schemes which may possibly be useful in future physical theories.

Strictly speaking, one has to consider a true infinity in the distribution of matter in all problems of the physics of continua. In the classical treatment, as usually given in textbooks of hydrodynamics and field theory, this is, however, not really essential, and in most theories serves merely as a convenient limiting model of *finite* systems enabling one to use the algorithms of the calculus. The usual introduction of the continuum leaves much to be discussed and examined critically. The derivation of the equations of motion for fluids, for example, runs somewhat as follows. One images a very large number N of particles, say with equal masses constituting a net approximating the continuum, which are to be studied. The forces between these particles are assumed to be given, and one writes Lagrange equations for the motion of N particles. The finite system of ODEs becomes in the limit $N = \infty$ one or several *partial* DEs. The Newtonian laws of conservation of energy and momentum are seemingly correctly formulated for the limiting case of the continuum. There appears at once, however, at least a possible objection to the unrestricted validity of this formulation. For the very fact that the limiting equations imply tacitly the continuity and differentiability of the functions

describing the motion of the continuum seems to impose various *constraints* on the possible motions of the approximating finite systems. Indeed, at any stage of the limiting process, it is quite conceivable for two neighboring particles to be moving in opposite directions with a relative velocity which does not need to tend to zero as N becomes infinite, whereas the continuity imposed on the solution of the limiting continuum excludes such a situation. There are, therefore, constraints on the class of possible motions which are not explicitly recognized. This means that a viscosity or other type of constraints must be introduced initially, singling out “smooth” motions from the totality of all possible ones. In some cases, therefore, the usual DEs of hydrodynamics may constitute a misleading description of the physical process.

On the other hand, nowadays development in technology and industry requires inclusion of micro-structural effects, which may play a crucial role when the characteristic magnitude of an excitation is of order of the characteristic size of the analyzed micro-structure object. In particular, we mention here modeling of crystal, polymer and composite materials, nano-materials, dynamics of cracks, description of hysteretic effects, mechanics of failures, fractals theory of phase transition and theory of plasticity [24], [55], [66], [91], [93], [111], [150], [199], [201], [203].

Micro-structural effects can be investigated within the frame of discrete models [152], however, even modern computers do not allow us to get reasonably validated results matched with the reasonably low computational time. Therefore, continuum description of micro- and nano-effects belongs to a challenging research topic. In addition, in many cases, one may apply modeling of mixed discrete-continuum systems, where its one part is continuous and the other is discrete.

1.7.2 Chain of Elastically Coupled Masses

Let us consider a simple example of a chain consisting of $n + 2$ particles of the same masses m lying in the rest in the points of axis x with the coordinates jh ($j = 0, 1, \dots, n, n + 1$) and linked by elastic couplings of stiffness c (Figure 1.7).

According to Hook's law the elastic force acting on the j -th mass is as follows:

$$\begin{aligned}\sigma_j(t) &= c[y_{j+1}(t) - y_j(t)] - c[y_j(t) - y_{j-1}(t)] \\ &= c[y_{j-1}(t) - 2y_j(t) + y_{j+1}(t)], \quad j = 1, 2, \dots, n,\end{aligned}$$

where $y_j(t)$ is the displacement of j -th point with regard to the equilibrium position.

Applying Newton second law the following ODEs are derived

$$m y_{jtt}(t) = c[y_{j-1}(t) - 2y_j(t) + y_{j+1}(t)], \quad j = 1, 2, \dots, n. \quad (1.246)$$

System (1.246) can be recast to the following form:

$$m \sigma_{jtt}(t) = c(\sigma_{j+1} - 2\sigma_j + \sigma_{j-1}), \quad j = 1, \dots, n. \quad (1.247)$$

Let the chain ends be fixed, then

$$y_0(t) = y_{n+1}(t) = 0. \quad (1.248)$$

In general, the initial conditions have the following form

$$y_j(t) = \varphi_j^{(0)}, \quad y_{jt}(t) = \varphi_j^{(1)} \quad \text{for } t = 0. \quad (1.249)$$

This model has been proposed by Newton in estimating sound velocity [70]. He assumed that sound in air moves in the same way as an elastic wave moves along the masses chain. Equation (1.247) has been studied by J. Bernoulli ([49], [205]) who considered the problem of massless finite elastic string composed of particles of equal masses uniformly located along the string.

As has been shown in [193], for an arbitrary solution to the problem (1.246), (1.248), (1.249) the full chain energy is constant. Besides, the solutions to the problems so far stated are asymptotically stable in the Lyapunov sense.

A solution to the problem (1.246), (1.248), (1.249) can be expressed via elementary functions with the help of a discrete variant of the method of variables separation. Therefore, normal oscillation forms are constructed

$$y_j(t) = C_j T(t), \quad j = 1, \dots, n,$$

where constants C_j present the solution to the eigenvalue problem:

$$-\lambda C_j = C_{j+1} - 2C_j + C_{j-1}, \quad j = 1, \dots, n, \quad C_0 = C_{n+1} = 0, \quad (1.250)$$

and the function $T(t)$ satisfies the following equation

$$mT_{tt} + c\lambda T = 0. \quad (1.251)$$

Solution to the eigenvalue problem (1.250) takes the following form [193]:

$$C_k = A \sin \frac{k\pi}{n+1}, \quad \lambda_k = 4\sin^2 \frac{k\pi}{2(n+1)}, \quad k = 1, 2, \dots, n. \quad (1.252)$$

We assume a solution to Equation (1.251) in the form $T = A \exp(i\omega t)$. Relations (1.251), (1.252) yield Lagrange formula for determination of frequencies ω_k of the discrete system:

$$\omega_k = 2\sqrt{\frac{c}{m}} \sin \frac{k\pi}{2(n+1)}, \quad k = 1, 2, \dots, n. \quad (1.253)$$

Since all values of λ_k are different, they are simple, and each of them is associated with one eigenvalue for $C_k(C_1^{(k)}, C_2^{(k)}, \dots, C_n^{(k)})$:

$$C_k = \operatorname{cosec} \frac{k\pi}{n+1} \left(\sin \frac{k\pi}{n+1}, \sin \frac{2k\pi}{n+1}, \dots, \sin \frac{nk\pi}{n+1} \right), \quad k = 1, 2, \dots, n. \quad (1.254)$$

Eigenvectors are mutually orthogonal, and a square of the moduli of eigenvector follows:

$$|C_k|^2 = \frac{n+1}{2} \operatorname{cosec}^2 \frac{k\pi}{n+1}, \quad k = 1, 2, \dots, n. \quad (1.255)$$

Each eigenfrequency (1.253) is associated with the normal oscillations form:

$$y_j^{(k)}(t) = C_j^{(k)} [A_k \cos(\omega_k t) + B_k \sin(\omega_k t)], \quad k = 1, 2, \dots, n. \quad (1.256)$$

A general solution to problem (1.247)–(1.249) is described by a sum of normal oscillations:

$$y_j(t) = \sum_{k=1}^n C_j^{(k)} [A_k \cos(\omega_k t) + B_k \sin(\omega_k t)], \quad j = 1, \dots, n. \quad (1.257)$$

Let us consider now the problem of masses chain movement, when a constant unit force acts on particles with zero number. A solution to this system is described by Equation (1.247) with the following boundary and initial conditions;

$$\sigma_0(t) = 1, \quad \sigma_{n+1}(t) = 0, \quad (1.258)$$

$$\sigma_j(t) = \sigma_{jt}(t) = 0 \quad \text{for } t = 0. \quad (1.259)$$

The nonhomogenous BVP (1.247), (1.258), (1.259) is transformed to the BVP with respect to Equation (1.247) with the homogenous boundary and nonhomogenous initial condition via the following relationship

$$\sigma_j(t) = 1 - \frac{jl}{n+1} + \sigma_{0j}(t).$$

In order to find function $\sigma_j^{(0)}(t)$, we apply the normal form method:

$$\sigma_j^{(k)}(t) = C_j^{(k)} [A_k \cos(\omega_k t) + B_k \sin(\omega_k t)], \quad k = 1, 2, \dots, n.$$

As a result, the following exact solution of the problem (1.246), (1.258), (1.259) is obtained:

$$\sigma_j(t) = 1 - \frac{jl}{n+1} - \frac{1}{n+1} \sum_{k=1}^n \sin \frac{\pi k j}{n+1} \operatorname{ctan} \frac{\pi k}{2(n+1)} \cos(\omega_k t),$$

$$j = 1, 2, \dots, n. \quad (1.260)$$

1.7.3 Classical Continuum Approximation

For large values n we usually apply the continuum approximation of the discrete problem, which in our case (Equations (1.247), (1.258), (1.259)) takes the following form:

$$m\sigma_{tt}(x, t) = \operatorname{ch}^2 \sigma_{xx}(x, t), \quad (1.261)$$

$$\sigma(0, t) = 1, \quad \sigma(l, t) = 0, \quad (1.262)$$

$$\sigma(x, 0) = \sigma_t(x, 0) = 0, \quad (1.263)$$

where $l = (n+1)h$.

Having at hand a solution to the BVPs (1.261)–(1.263), one may transit to a solution of the discrete medium according to the formulas

$$\sigma_j(t) = \sigma(jh, t), \quad j = 0, 1, \dots, n, n+1. \quad (1.264)$$

Formally, this approximation can be obtained in the following way. Let us denote by D the difference operator occurred in Equation (1.247):

$$m\sigma_{jt}(t) = cD\sigma(t). \quad (1.265)$$

Using the operator $\exp(h \frac{\partial}{\partial x})$ one gets [152]:

$$D = \exp\left(h \frac{\partial}{\partial x}\right) + \exp\left(-h \frac{\partial}{\partial x}\right) - 2 = -4\sin^2\left(-\frac{ih}{2} \frac{\partial}{\partial x}\right). \quad (1.266)$$

In what follows we explain the obtained relation. The Maclaurin formula for the infinitely differentiated function $F(x)$ takes the form

$$F(x+1) = \left[1 + \frac{\partial}{\partial x} + \frac{1}{2!} \frac{\partial^2}{\partial x^2} + \dots\right] F(x) = \exp\left(\frac{\partial}{\partial x}\right) F(x). \quad (1.267)$$

Expressions of the form $\exp(\partial/\partial x)$ are called pseudo-differential operators. Using conditions (1.265)–(1.267), we recast the system (1.247) in the form of pseudo-differential equation [178]:

$$m \frac{\partial^2 \sigma}{\partial t^2} + 4c \sin^2 \left(-\frac{ih}{2} \frac{\partial}{\partial x} \right) \sigma = 0. \quad (1.268)$$

Development of the pseudo-differential operator into the Maclaurin series yields:

$$\sin^2 \left(-\frac{ih}{2} \frac{\partial}{\partial x} \right) = - \left(\frac{h^2}{4} \frac{\partial^2}{\partial x^2} + \frac{h^4}{48} \frac{\partial^4}{\partial x^4} + \frac{h^6}{1440} \frac{\partial^6}{\partial x^6} + \dots \right). \quad (1.269)$$

Keeping only the first term in the series (1.269), we obtain a continuum approximation (1.261). Application of the Maclaurin series requires a small difference in displacements of the neighboring particles. Physically it means that we are investigating vibrations of a few particles located on the space period (see Figure 1.15), i.e. we proceed within the so-called long wave approximation. Note that the vertical axis corresponds to displacements in direction x , and we deal with the one-dimensional problem.

The continuum system (1.261) has the following infinite spectrum:

$$\alpha_k = \pi \sqrt{\frac{c}{m}} \frac{k}{n+1}, \quad k = 1, 2, \dots \quad (1.270)$$

Although formulas (1.270) approximate reasonably good low frequencies of vibrations of the discrete system (1.253), but the n -th frequency α_k of continuum system differs from the n -th frequency of discrete system ω_k more than 50%. Accuracy of approximation (1.270) can be increased, but the following general conclusion follows. Frequencies of the continuum system $\omega_{n+1}, \omega_{n+2}, \dots$ do not have any relations to those of the discrete system (see [200, chapter 20]).

Observe that L.I. Mandelshtam criticized the described method [167]; however today it is rigorously approved mathematically with the help of the Fourier transform [152].

1.7.4 “Splashes”

It is not difficult to derive the exact solution to problem (1.261)–(1.263) using the D’Alembert method and operational calculus [154]:

$$\sigma(x, t) = H \left(nh \arcsin \left| \sin \left(\frac{\pi}{2n} \sqrt{\frac{c}{m}} t \right) \right| - x \right), \quad (1.271)$$

where $H(\dots)$ stands for Heriside’s function.

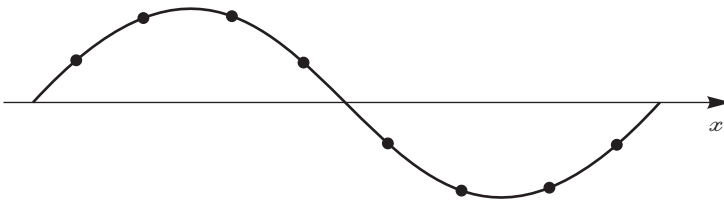

Figure 1.15 Solution form $\sigma = \sigma(x, t)$ in the fixed time instant $t = \text{const}$ (points correspond to a discrete system whereas solid curve represents a continuum system)

Table 1.10 Splashes

n	8	16	32	64	128	256	$n \rightarrow \infty$
P_n	1,7561	2,0645	2,3468	2,6271	2,9078	3,1887	$P_n \rightarrow \infty$

Formula (1.271) implies that for all time instants the following estimation holds

$$|\sigma(x, t)| \leq 1. \quad (1.272)$$

It is tempting to extend the estimation (1.272) into a discrete system [261] using relation (1.264). However, numerical and analytical investigations [154], [193], [105], [106], [107] have shown that one needs to include a difference between the global and local characteristics of a discrete system. Investigation the low spectrum of a discrete systems allows for a smooth transition into an averaged description. However, in the case of external excitations solutions of discrete systems do not smoothly transit into the wave equation solutions for $h \rightarrow 0$ [178]. It has been numerically shown [154], [193], [105], [106], [107] that for certain particles in the discrete chain the quantity $P_j = |\sigma_j(t)|$ can essentially overcome the bounded value 1 [105] (see Table 1.10).

It is interesting to note that the magnitude of splashes does not depend on the parameter m/c .

Amplitude of chain oscillations becomes arbitrary large with increase of N , but the system energy is constant and does not depend on N . However we do not deal here with a paradox, since oscillations amplitude is of order of the sum of $\sigma_j(t)$, whereas the potential energy is of the order of square of those quantities [193].

Amplitude of vibrations of a particle with the fixed number is bounded for $N \rightarrow \infty$, but the amplitude of vibrations of a particle with a certain number increases with the increase of N and tends to infinity for $N \rightarrow \infty$ in a way to that of $\ln N$ [193].

Note that a rigorous prove of the above observations is achieved assuming that $N + 1$ is either a simple number or a power of two. However, this result is of negligible meaning [193].

In the language of mechanics what we just said means that when analyzing the so-called "local properties" of a one-dimensional continuous medium, one cannot treat the medium as the limiting case of a linear chain of point masses, obtained when the number of points increases without limit [154]. Physically, this phenomenon can be interpreted in a rather simple way. Excited vibrations include both low and high harmonics, and the latter ones are defined via the continuum approximation with relatively large errors.

It is tempting to construct an improved theory of continuum media including splash effects. The mentioned theory should reasonably good describe harmonics of a solution with respect to an arbitrary period associated with the problem. In mathematical sense, the problem is reduced to that of approximation of nonlocal (difference) operator by the local (differential) one.

1.7.5 Envelope Continualization

It has been observed that asymptotics appear in pairs. Classical continuum approximation yields reliable results with respect to low part of the spectrum of the finite chain of particles.

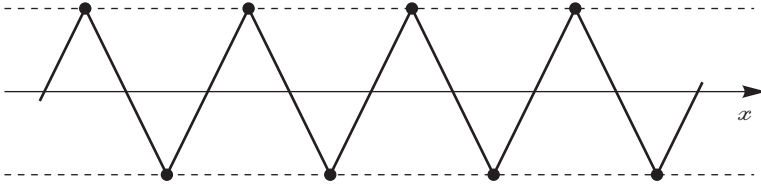

Figure 1.16 Saw-tooth chain vibrations

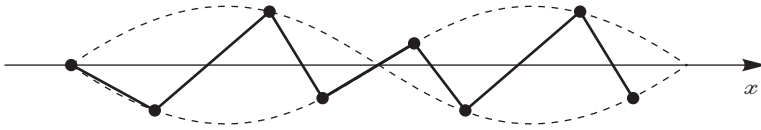

Figure 1.17 Envelope continualization

On the other hand, the maximum frequency of vibrations occurs in the case of the saw-tooth vibrations (Figure 1.16)

In this case $\sigma_k = (-1)^k \Omega$, and the equation yielding Ω has the following form

$$m\Omega_{tt} + 4c\Omega = 0.$$

In the case of oscillations close to a saw-tooth shape, one may use the so called short-wave approximation (envelope continualization) [149] (Figure 1.17). A change of variables

$$\sigma_k = (-1)^k \Omega_k \quad (1.273)$$

allows us to transit from Equations (1.247), (1.258), (1.259) to the following BVP:

$$m\Omega_{ktt} + c(4\Omega_k + \Omega_{k-1} - 2\Omega_k + \Omega_{k+1}) = 0, \quad (1.274)$$

$$\Omega_0 = 1, \quad \Omega_{n+1} = 0, \quad (1.275)$$

$$\Omega_k = \Omega_{kt} = 0 \quad \text{for } t = 0, \quad k = 0, 1, \dots, n+1. \quad (1.276)$$

Further, the following relation is used:

$$\begin{aligned} \Omega_{k-1} - 2\Omega_k + \Omega_{k+1} &= -4\sin^2\left(-\frac{ih}{2}\frac{\partial}{\partial x}\right)\Omega = \\ &= \left(h^2\frac{\partial^2}{\partial x^2} + \frac{h^4}{12}\frac{\partial^4}{\partial x^4} + \frac{h^6}{320}\frac{\partial^6}{\partial x^6} + \dots\right)\Omega. \end{aligned} \quad (1.277)$$

Substituting Equation (1.277) into Equation (1.274) considering h^2 as the small parameter, and taking into account only terms of zero and first orders with respect to h^2 , we get

$$m\Omega_{tt} + 4c\Omega + ch^2\Omega_{xx} = 0. \quad (1.278)$$

It is not difficult to derive the boundary and initial conditions to Equation (1.278):

$$\begin{aligned}\Omega &= 1 \quad \text{for } x = 0, \quad \Omega = 0 \quad \text{for } x = l, \\ \Omega &= \Omega_t = 0 \quad \text{for } t = 0.\end{aligned}$$

The approaches described so far (classical continualization and envelope continualization) can be treated as a discrete model with reasonably good accuracy, and it exhibits two continual approximations, i.e. for a chain and for an envelope.

1.7.6 Improvement Continuum Approximations

In what follows we discuss the problem of the improved continuum approximations. If in the series (1.269) we keep three first terms, then the following equation is obtained:

$$m \frac{\partial^2 \sigma}{\partial t^2} = ch^2 \left(\frac{\partial^2}{\partial x^2} + \frac{h^2}{12} \frac{\partial^4}{\partial x^4} + \frac{h^4}{360} \frac{\partial^6}{\partial x^6} \right) \sigma. \quad (1.279)$$

The problem regarding boundary conditions of Equation (1.279) does not belong to trivial ones (see the interesting discussion by Raman and Bohr regarding periodic conditions for the chain [61]). One may define them only if we determine the chain movement for $k = -1, -2, -3, k = N + 2, N + 3, N + 4$. In other words, the boundary is substituted by the boundary domain [152]. In particular, in the case of periodic extension (simple support), we get

$$\sigma = \sigma_{xx} = \sigma_{xxx} = 0 \quad \text{for } x = 0, l. \quad (1.280)$$

If we take $\sigma_k(t) = 0$ for $k = -1, -2, -3, k = N + 2, N + 3, N + 4$, then BCs (1.280) refer to clamping

$$\sigma = \sigma_x = \sigma_{xxx} = 0 \quad \text{for } x = 0, l.$$

Comparison of the n -th frequency of the continuum system (1.279), (1.280) with the corresponding frequency of a discrete system exhibits the essential increase of accuracy (we have 2.1 instead of 2 in the exact solution, which yields the error of 5%). Note that the estimation of the continuum approximation error with respect to maximal frequency of the discrete chains is somehow conventional, but most simple.

In the general case, keeping in (1.269) N terms, one gets the so-called intermediate continuum models [105]. It is assumed that for $N = \infty$ the exact input equation is obtained:

$$m \frac{\partial^2 \sigma}{\partial t^2} = 2c \sum_{k=1}^N \frac{h^{2k}}{(2k)!} \frac{\partial^{2k} \sigma}{\partial x^{2k}}. \quad (1.281)$$

BCs for Equation (1.281) have the following form:

$$\frac{\partial^{2k} \sigma}{\partial x^{2k}} = 0 \quad \text{for } x = 0, l, \quad k = 0, 1, \dots, N - 1 \quad (1.282)$$

or

$$\sigma = 0, \quad \frac{\partial^{2k-1} \sigma}{\partial x^{2k-1}} = 0 \quad \text{for } x = 0, l, \quad k = 1, \dots, N - 1. \quad (1.283)$$

The corresponding BVPs are correct (they are also stable during the numerical realization) for odd N . In this case Equation (1.281) is of the hyperbolic type [106]. Application of the intermediate continuum models allow us to determine the splash effects [105].

Observe that analogous ideas presented so far are used in the method of differential approximations to estimate errors of difference systems [227].

Construction of intermediate continuum models is based on the development of the difference operator into the Taylor series. It seems that the more effective ones are continuum models relying on the Padé approximations, which are called quasi-continuum approximations [84], [211], [212]. In order to approximate the operator (1.269) within the Padé algorithm, one may also apply either Fourier or Laplace transforms. If one keeps only three first terms in the series (1.269), then the Padé approximation follows

$$\frac{\partial^2}{\partial x^2} + \frac{h^2}{12} \frac{\partial^4}{\partial x^4} \approx \frac{\frac{\partial^2}{\partial x^2}}{1 - \frac{h^2}{12} \frac{\partial^2}{\partial x^2}}.$$

The corresponding quasi-continuum model takes the form

$$m \left(1 - \frac{h^2}{12} \frac{\partial^2}{\partial x^2} \right) \sigma_{tt} - ch^2 \sigma_{xx} = 0. \quad (1.284)$$

BCs for Equation (1.284) have the following form

$$\sigma = 0 \quad \text{for } x = 0, l. \quad (1.285)$$

Error estimation of the n -th frequency in comparison to the discrete chain is of the amount of 16.5%. Equation (1.284) has lower dimension in comparison to approximation (1.279).

Now, having in hand both long- and short-wave asymptotes, one may apply two points Padé approximation (see chapter 9.2). Let us construct two-point Padé approximation of difference operator, using the first term of series (1.269). Besides, we require that n -th frequency of vibrations of the continuum system should coincide with the corresponding frequency of the discrete system $\omega_n = 2\sqrt{c/m} \sin[n\pi/2(n+1)]$. For large values of n one may apply the following approximation

$$\alpha_n \approx 2\sqrt{c/m}. \quad (1.286)$$

Continuum approximation is governed by the following equation

$$m \left(1 - a^2 h^2 \frac{\partial^2}{\partial x^2} \right) \sigma_{tt} - ch^2 \sigma_{xx} = 0, \quad (1.287)$$

with the BCs (1.285).

Frequencies of vibrations yielded by the BVP (1.287), (1.285) follow

$$\alpha_k = \pi \sqrt{\frac{c}{m} \frac{k}{\sqrt{(n+1)^2 + \alpha^2 k^2}}}, \quad k = 1, 2, \dots \quad (1.288)$$

Application of formula (1.286) yields $a^2 = 0, 25 - \pi^{-2}$. The largest error in estimation of the eigenfrequencies is achieved for $k = [0, 5(n+1)]$ and does not overcome 3%. Approximation (1.287) allows us to include the splash phenomenon.

1.7.7 Forced Oscillations

Let us begin with the classical continuum approximations. A solutions to the Equation (1.261) is as follows

$$\sigma = 1 - \frac{x}{l} + u(x, t),$$

and functions $u(x, t)$ are defined via the following formulas

$$m \frac{\partial^2 u}{\partial t^2} = \text{ch}^2 \frac{\partial^2 u}{\partial x^2}, \quad (1.289)$$

$$u(0, t) = u(l, t) = 0, \quad (1.290)$$

$$u(x, 0) = -1 + \frac{x}{l}, \quad u_t(x, 0) = 0. \quad (1.291)$$

A solution to the BVP (1.289)–(1.291) is found using the Fourier method, and has the following form

$$\sigma = 1 - \frac{x}{l} - \frac{2}{\pi} \sum_{k=1}^{\infty} \frac{1}{k} \sin\left(\frac{k\pi x}{l}\right) \cos(\alpha_k t), \quad (1.292)$$

where $\alpha_k, k = 1, 2, 3, \dots$

Formula (1.292) describes oscillations either of a string or a rod. If we are aimed on approximation of the particle chain oscillations, then we keep only n first harmonics in the infinite sum, since the remaining ones have no relations to the chain movements:

$$\sigma = 1 - \frac{x}{l} - \frac{2}{\pi} \sum_{k=1}^n \frac{1}{k} \sin\left(\frac{k\pi x}{l}\right) \cos(\alpha_k t). \quad (1.293)$$

Observe that solution (1.260) and (1.293) differ from each other not only regarding frequencies α_k and ω_k (formulas (1.253) and (1.270), respectively). In order to overcome this drawback one may use either equations (1.279), (1.284) or (1.286). However, also the coefficients of the series (1.292) and (1.293) understood as projections onto the normal oscillation forms at a discrete and continuum system $\frac{1}{n+1} \text{ctan} \frac{\pi k}{2(n+1)}$ and $\frac{2}{\pi k}$ differ strongly for $k \gg 1$. This phenomenon appears due to the development into series regarding normal forms for a discrete system using the summation of k from 1 to n , whereas integration with respect to x is carried out from 0 to l in the case of a continuous system. One may improve the results using the Euler-Maclaurin formulas [100], [101]:

$$\sum_{k=0}^{n+1} f(k) = \int_0^{n+1} f(x) dx + \frac{1}{2} [f(0) + f(n+1)] + \sum_{j=1}^{\infty} \frac{(-1)^{j+1}}{j+1} B_j \left[\frac{d^j f(n+1)}{dx^j} - \frac{d^j f(0)}{dx^j} \right]. \quad (1.294)$$

Here B_j are Bernoulli numbers, where $B_0 = 1, B_1 = -1/2, B_2 = 1/6, B_3 = 0$.

One may also apply the following recurrence formula:

$$B_n = -\frac{1}{n+1} \sum_{k=1}^n C_{n+1}^{k+1} B_{n-k}.$$

In order to introduce the development regarding normal forms of a discrete system, one may apply formulas 4.4.2.6, 4.4.1.5 and 4.4.1.7 taken from handbook [209]

$$\sum_{k=0}^{n+1} \sin^2 \frac{k\pi j}{n+1} = \frac{n+1}{2}, \quad (1.295)$$

$$\sum_{k=0}^{n+1} \left(1 - \frac{j}{n+1}\right) \sin \frac{k\pi j}{n+1} = \frac{1}{n+1} \cotan \frac{j\pi}{2(n+1)}. \quad (1.296)$$

The corresponding integrals follow

$$\int_0^{n+1} \sin^2 \frac{\pi j x}{n+1} dx = \frac{n+1}{2}, \quad (1.297)$$

$$\int_0^{n+1} \left(1 - \frac{x}{l}\right) \sin \frac{\pi j x}{n+1} dx = \frac{2}{\pi j}. \quad (1.298)$$

The values of sum (1.295) and integral (1.297) coincide. Applying the Euler-Mclaurin formula one may get the value of the continuum projection more closer to the sum value (1.296):

$$\begin{aligned} \sum_{k=0}^{n+1} \left(1 - \frac{j}{n+1}\right) \sin \frac{k\pi j}{n+1} &= \\ \int_0^{n+1} \left(1 - \frac{x}{l}\right) \sin \frac{\pi j x}{n+1} dx + \frac{1}{2} [\sin 0 + \sin(j\pi)] - \frac{j\pi}{6(n+1)} \cos 0 + \dots &= \\ \frac{2}{\pi j} \left[1 - \frac{\pi^2 j^2}{12(n+1)^2}\right]. \end{aligned} \quad (1.299)$$

According to formula (1.299), one may construct a simple relation relatively well, approximating the sum (1.296) for arbitrary values of j from $j = 1$ to $j = n$.

For this purpose, the second term in the r.h.s. of Equation (1.299) should be substituted by the following approximation

$$\sum_{k=0}^{n+1} \left(1 - \frac{j}{n+1}\right) \sin \frac{k\pi j}{n+1} \approx \frac{2}{\pi j} \left[1 - \frac{j^2}{(n+1)^2}\right].$$

1.8 Averaging and Homogenization

We begin with a terminology background. We understand by averaging the process applied to nonlinear problems in mechanics, whereas homogenization deals with the averaging process regarding DEs with quickly changing coefficients. In both approaches the same idea of splitting of fast and slow solution components is applied (see Figure 1.18).

1.8.1 Averaging via Multiscale Method

One may apply different forms of averaging procedure beginning with the Van der Pol method of slowly changeable amplitudes [63] up to the Hilbert transformation [238]. However, these methods cannot be interpreted in a simple way. Namely, the following question appears: why should the averaging with respect to fast time be carried out and why should the slow time t be frozen as well as the function of t while applying averaging with respect to fast time? The multiscale method allows us to clarify this averaging approach ([257], p. 130).

In what follows we apply the multiscales method. It should be noted that all of the asymptotic methods yield the same equation, which has been pointed out by N.N. Moiseev [189].

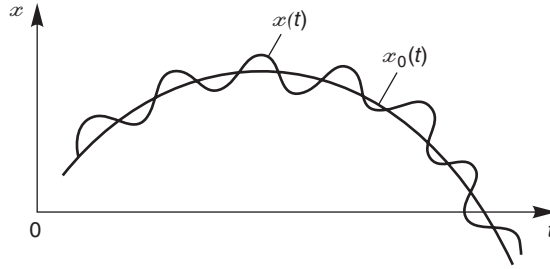

Figure 1.18 Splitting of the input solution into a sum of slow (averaged) and fast changeable components

The multiscale method presents the most regular approach to find higher order approximations. On the other hand, this method in many cases yields a solution in the form of convergent series ([257], p. 144).

We begin with the Duffing equation with small nonlinearity:

$$\ddot{x} + x + \epsilon x^3 = 0, \quad \epsilon \ll 1. \tag{1.300}$$

Linear equation ($\epsilon = 0$) has the following general solution:

$$x_0 = A \cos t + B \sin t, \tag{1.301}$$

where $A, B = \text{const}$.

It is tempting to assume that for $0 < \epsilon \ll 1$ a solution to Equation (1.300) can be presented in the form (1.301), where A and B are functions slowly changed in time t .

According to the multiscale method two scales we introduced the slow time $\tau = \epsilon t$ keeping notation t for the “fast time,” and hence

$$\frac{d}{dt} = \frac{\partial}{\partial t} + \epsilon \frac{\partial}{\partial \tau}.$$

A solution x is presented in the following series form

$$x = x_0(t, \tau) + \epsilon x_1(t, \tau) + \dots,$$

and we have

$$\begin{aligned} \frac{dx}{dt} &= \frac{\partial x_0}{\partial t} + \epsilon \left(\frac{\partial x_0}{\partial \tau} + \frac{\partial x_1}{\partial t} \right) + \dots, \\ \frac{d^2x}{dt^2} &= \frac{\partial^2 x_0}{\partial t^2} + \epsilon \left(2 \frac{\partial^2 x_0}{\partial \tau \partial t} + \frac{\partial^2 x_1}{\partial t^2} \right) + \dots \end{aligned}$$

After splitting with respect to ϵ , the following recurrent series is obtained

$$\frac{\partial^2 x_0}{\partial t^2} + x_0 = 0, \tag{1.302}$$

$$\frac{\partial^2 x_1}{\partial \tau^2} + x_1 = 2 \frac{\partial^2 x_0}{\partial \tau \partial t} - x_0^3, \tag{1.303}$$

.....

A solution to Equation (1.302) can be written in the following form:

$$x_0 = A(\tau) \cos t + B(\tau) \sin t. \quad (1.304)$$

Equation (1.303) is cast to the form:

$$\frac{\partial^2 x_1}{\partial \tau^2} + x_1 = P(t, \tau) = 2 \frac{dA}{d\tau} \sin t - 2 \frac{dB}{d\tau} \cos t - (A \cos t + B \sin t)^3. \quad (1.305)$$

Lack of secular terms in solution to Equation (1.303) requires

$$\int_0^{2\pi} P(t, \tau) \cos t \, dt = 0, \quad \int_0^{2\pi} P(t, \tau) \sin t \, dt = 0. \quad (1.306)$$

Condition (1.306) implies the following system of two first order ODEs with respect to functions $A(\tau)$, $B(\tau)$:

$$\frac{dA}{d\tau} = \frac{3}{8}(A^2 + B^2)B, \quad \frac{dB}{d\tau} = -\frac{3}{8}(A^2 + B^2)A.$$

Analogously, one may derive a system of averaged equations if the zero order solution of Equation (1.300) has the following form:

$$x = a(t) \cos(t + \theta(\tau)) \quad (1.307)$$

under the condition

$$\frac{dx}{dt} = -a(t) \sin(t + \theta(\tau)). \quad (1.308)$$

Now functions $a(t)$ and $\theta(\tau)$ have the meaning of an amplitude and phase of vibrations, respectively.

Differentiating formula (1.307) regarding time t yields:

$$\frac{dx}{dt} = -a \sin(t + \theta) + \frac{da}{dt} \cos(t + \theta) - \frac{d\theta}{dt} a \sin(t + \theta). \quad (1.309)$$

Substituting Equation (1.309) into Equation (1.300) and using Equation (1.308), one gets:

$$\frac{da}{dt} \sin(t + \theta) + a \frac{d\theta}{dt} \cos(t + \theta) = \epsilon a^3 \cos^3(t + \theta). \quad (1.310)$$

Solving Equations (1.309) and (1.310) with respect to $\frac{da}{dt}$ and $\frac{d\theta}{dt}$, one obtains:

$$\frac{da}{dt} = \epsilon a^3 \cos^3(t + \theta) \sin(t + \theta), \quad (1.311)$$

$$\frac{d\theta}{dt} = \epsilon a^2 \cos^4(t + \theta). \quad (1.312)$$

Since a and θ are slowly changed functions in time (ϵ is small) then their changes within the time $T = 2\pi$, being a period of the right-hand sides, is small. Averaging of the r.h.s. of Equations (1.311) and (1.312) on the interval $[t, t + T]$, where the quantities a and θ appearing in the right-hand sides of equations are assumed to be constant, yields

$$\frac{1}{T} \int_0^T \cos^3(t + \theta) \sin(t + \theta) dt = 0, \quad \frac{1}{2\pi} \int_0^{2\pi} \cos^4(t + \theta) dt = \frac{3}{8}.$$

It further follows that

$$\frac{da}{dt} = 0, \quad (1.313)$$

$$\frac{d\theta}{dt} = \frac{3}{8}\varepsilon a^2. \quad (1.314)$$

Equation (1.313) implies that a is constant, whereas relation (1.314) yields $\theta = \frac{3}{8}\varepsilon a_0^2 t + \theta_0$. Hence, in the first order approximation we get

$$u = a_0 \cos\left(1 + \frac{3}{8}\varepsilon A_0^2\right)t + O(\varepsilon).$$

It is clear that zero order solutions presented by expressions (1.304) and (1.307) are equivalent.

Improvement term to the vibration frequency coincides with that obtained via other methods (for instance via Lindstedt-Poincaré method).

Observe that not only linear equations may serve as a zero order approximation. For example, in reference [79], nonlinear DEs are taken from the beginning (zero order approximation) allowing to achieve final solutions in the form of elliptic functions. Although the procedure is more complicated, but the nonlinear effects are taken already in the first equation of the successive series of equations.

1.8.2 *Frozing in Viscoelastic Problems*

The viscoelastic problems are associated with the integro-differential equations. As a typical example one may consider equation governing vibrations of the viscoelastic rectangular plate taking into account geometric nonlinearity:

$$\Gamma(\nabla^4 w) - \Gamma(N\nabla^2 w) + \rho_1 w_{tt} = 0,$$

where $\Gamma(\varphi) = \varphi + \int_0^t R(t-\tau)\varphi(\tau)d\tau$, $N = \frac{6}{abh^2} \int_0^a \int_0^b (w_x^2 + w_y^2) dx dy$, $\rho_1 = \frac{\rho h}{D}$, and R stands for the relaxation kernel.

If the plate is simply supported, then one may separate the variables, and applying

$$w = A(t) \sin \frac{m\pi x}{a} \sin \frac{n\pi y}{b}$$

the following nonlinear integro-differential equation regarding $A(t)$ is obtained

$$B(m, n)\Gamma(A + 1, 5h^{-2}A^3) + \rho_1 A_{tt} = 0, \quad (1.315)$$

where

$$B(m, n) = \pi^4 \left[\left(\frac{m}{a}\right)^2 + \left(\frac{n}{b}\right)^2 \right]^2.$$

Since an exact solution of Equation (1.315) cannot be achieved, therefore we are going to simplify equation with respect to the low frequencies. Let us begin with a study of the following integral

$$I(t) = \int_0^t A(\tau)R(t-\tau)d\tau. \quad (1.316)$$

If the variable $A(\tau)$ slowly changes with respect to the change of the kernel relaxation $R(t - \tau)$, then one may introduce freezing for $t = \tau$ assuming that

$$I(t) \approx A(t)I_1(t),$$

where $I_1(t) = \int_0^t R(t - \tau)d\tau$.

The so far described approach is known as the method of freezing [103], [104]. Applying this method to Equation (1.315) yields

$$B[1 + I_1(t)](A + 1, 5h^{-2}A^3) + \rho_1 A_{tt} = 0. \quad (1.317)$$

Note that Equation (1.317) is an ODE one with variable coefficients. Now we apply the averaging to solve it. Assuming

$$I_2(t) \approx \lim_{T \rightarrow \infty} \frac{1}{T} \int_0^T I_1(t)dt,$$

the following ODE with constant coefficients is obtained

$$B[1 + I_2](A + 1, 5h^{-2}A^3) + \rho_1 A_{tt} = 0.$$

1.8.3 The WKB Method

The origin of this method requires further investigations [133]. However, we follow the traditional approach referring to Wentzel, Kramers and Brillouin. We consider the longitudinal vibrations of a rod ($0 \leq x \leq l$) with nonconstant stiffness $EF\varphi_1(x)$ and density $\rho F\varphi_2(x)$, where E, F, ρ are constants [34], [235].

Input equation and BCs are as follows

$$EF \frac{d}{dx} \left[\varphi_1(x) \frac{du}{dx} \right] + \rho \varphi_2(x) F \omega^2 u = 0, \quad (1.318)$$

$$u(0) = u(L) = 0. \quad (1.319)$$

In the nondimensional variables, we get

$$\frac{d^2 u}{d\xi^2} + q(\xi) \frac{du}{d\xi} + q_1(\xi) \lambda^2 u = 0, \quad (1.320)$$

where $q(\xi) = \frac{\varphi_1'(\xi)}{\varphi_1(\xi)}$, $q_1(\xi) = \frac{\varphi_2(\xi)}{\varphi_1(\xi)}$, $\lambda^2 = \frac{\rho \omega^2}{EL^2}$, $\xi = \frac{x}{L}$.

Let us construct a solution with respect to high frequencies $\lambda^2 \gg 1$. For this purpose we apply the following change of variables

$$u = \exp(\lambda \psi(\xi)). \quad (1.321)$$

Substituting Ansatz (1.321) into Equations (1.320) one gets

$$\lambda^2 \psi'^2 + \lambda \psi' \psi'' + \lambda q \psi' + q_1 \lambda^2 = 0. \quad (1.322)$$

We are looking for a solution to Equation (1.322) in the series form with respect to λ^{-1} :

$$\psi = \psi_0 + \lambda^{-1} \psi_1 + \lambda^{-2} \psi_2 + \dots,$$

Terms of this series satisfy the following recurrent system of equations

$$\psi_0'^2 + q_1 = 0, \quad (1.323)$$

$$2\psi_1' + \psi_0'' + q = 0, \quad (1.324)$$

.....

Equation (1.323) yields

$$\psi_0 = \pm i\sqrt{q_1(\tau)}.$$

Approximating solution of Equation (1.318) follows

$$u \approx C_1 \sin \left(\int_0^\xi \sqrt{q_1(\tau)} d\tau \right) + C_2 \cos \left(\int_0^\xi \sqrt{q_1(\tau)} d\tau \right).$$

BCs (1.319) imply

$$C_2 = 0, \sin \left(\lambda \int_0^1 \sqrt{q_1(\tau)} d\tau \right) = 0,$$

and hence

$$\lambda \int_0^1 \sqrt{q_1(\tau)} d\tau = \pi n, \quad n = 1, 2, 3, \dots$$

Finally, the following formula allows us to find a frequency

$$\omega = \frac{\pi n L \sqrt{E}}{\sqrt{\rho} \int_0^\xi \sqrt{q_1(\tau)} d\tau}.$$

In what follows we show other modification of the WKB method using the example of vibrations of a rod with variable transversal crosssection, governed by the following equation

$$\frac{d^2}{dx^2} \left[EI\varphi_1(x) \frac{d^2 w}{dx^2} \right] - \rho\varphi_2(x) F\omega^2 w = 0. \quad (1.325)$$

We study the clamped rod faces, and hence

$$w = \frac{dw}{dx} = 0 \quad \text{for } x = 0, L. \quad (1.326)$$

The nondimensional form follows

$$\varepsilon^4 \frac{d^2}{d\xi^2} \left[\varphi_1 \frac{d^2 w}{d\xi^2} \right] - \varphi_2 w = 0, \quad (1.327)$$

$$w = \frac{dw}{d\xi} = 0 \quad \text{for } \xi = 0, 1, \quad (1.328)$$

where $\varepsilon^4 = \frac{EI}{\omega^2 \rho FL^4}$, $\xi = \frac{x}{L}$.

A solution to the Equation (1.327) is sought in the form

$$w = \exp \left(\varepsilon^{-1} \int_0^\xi \psi(\tau) d\tau \right) [u_0(\xi) + \varepsilon u_1(\xi) + \varepsilon^2 u_2(\xi) + \dots]. \quad (1.329)$$

Substituting the Ansatz (1.329) into Equation (1.327), after splitting with regard to ε , the following recurrent system of equations is obtained:

$$(\varphi_1 \psi^4 - \varphi_2) u_0 = 0, \tag{1.330}$$

$$4\varphi_1 \psi^3 u_0' + 6\varphi_1 \psi^2 \psi' u_0 + 2\psi^3 \varphi_1' u_0 = 0, \tag{1.331}$$

.....

Equation (1.330) gives the following solution:

$$\psi_{1,2} = \pm \left(\frac{\varphi_2}{\varphi_1} \right)^{1/4}, \quad \psi_{1,2} = \pm i \left(\frac{\varphi_2}{\varphi_1} \right)^{1/4}.$$

Equation (1.331) yields

$$u_0(\xi) = \frac{1}{\psi^{3/2} \varphi_1^{1/2}}.$$

General solution to Equation (1.327) has the following form (in the first order approximation):

$$w = C_1 \sin \left(\varepsilon^{-1} \int_0^\xi \psi(\tau) d\tau \right) u_0(\xi) + C_2 \cos \left(\varepsilon^{-1} \int_0^\xi \psi(\tau) d\tau \right) u_0(\xi) + C_3 \exp(-\varepsilon^{-1} \psi(0)\xi) u_0(0) + C_4 \exp(-\varepsilon^{-1} \psi(1)(1 - \xi)) u_0(1). \tag{1.332}$$

In expression (1.332), for quickly decaying components, the function $u_0(\xi)$ is frozen on one of the interval ends.

BCs (1.327) allow us to define the vibration frequency

$$\omega = \pi^2(n + 0,5)^2 \sqrt{\frac{EI}{\rho FL^4} \left[\int_0^l \left[\frac{\varphi_2(x)}{\varphi_1(x)} \right]^{1/4} dx \right]^{-2}}, \quad n = 1, 2, 3, \dots \tag{1.333}$$

Formula (1.333) for $\varphi_1 = \varphi_2 = 1$ coincides with Bolotin formula (4.1.17). In other words, the WKB method generalizes the method of Bolotin into the problems with variable coefficients.

1.8.4 Method of Kuzmak-Whitham (Nonlinear WKB Method)

Efficient generalization of the averaging method for ODEs has been proposed by Kuzmak [153] and for PDEs by Whitham [256]. According to the latter method, a quickly oscillating solution to a PDE has the following form:

$$w = w_0(\tau, \mathbf{x}, t) + \varepsilon w_1(\tau, \mathbf{x}, t) + \dots, \quad \tau = \varepsilon^{-1} S(\mathbf{x}, t). \tag{1.334}$$

Functions $w_i(\tau, \mathbf{x}, t)$ are periodic with respect to τ . The Kuzmak-Whitham method can be treated as a variant of the multiscale method, where τ plays a role of a fast variable. Substituting Ansatz (1.334) into the input PDE, and after splitting with respect to ε , the problem is reduced to ODEs, where the first equation is nonlinear one, and the remaining equations are linear and nonhomogenous. Solvability conditions of these equations are reduced to a system

of nonlinear PDEs yielding a phase $S(\mathbf{x}, t)$ and dependence of the functions being sought on slow variables \mathbf{x}, t . Therefore, the Kuzmak-Whitham method generalizes the WKB method into a nonlinear case. We apply the method illustrated so far to construct simplified nonlinear evolution equations of shallow shells, which yields Berger equation as the particular case (see also [124]).

In what follows we consider the shallow shell with the curvatures R_1 and R_2 and dimensions a and b . The governing nondimensional equations follow:

$$\begin{aligned} \frac{1}{12(1-\nu^2)}\varepsilon^2\nabla^2\tilde{w} - \nabla_k\tilde{F} - \varepsilon(\tilde{F}_{\xi\xi}\tilde{w}_{\eta\eta} - 2\tilde{F}_{\xi\eta}\tilde{w}_{\xi\eta} + \tilde{F}_{\eta\eta}\tilde{w}_{\xi\xi}) + \tilde{w}_{\tau\tau} = 0, \\ \nabla^4\tilde{F} + \nabla_k\tilde{w} + \varepsilon(\tilde{w}_{\xi\xi}\tilde{w}_{\eta\eta} - \tilde{w}_{\xi\eta}^2) = 0, \end{aligned} \quad (1.335)$$

$$\begin{aligned} \tilde{F}_{\eta\eta} &= \frac{1}{1-\nu^2}[\tilde{u}_\xi - \varepsilon_{10}\tilde{w} + 0, 5\varepsilon\tilde{w}_\xi^2 + \nu(\tilde{v}_\eta - \varepsilon_{20}\tilde{w} + 0.5\varepsilon\tilde{w}_\eta^2)], \\ \tilde{F}_{\xi\xi} &= \frac{1}{1-\nu^2}[\tilde{v}_\eta - \varepsilon_{20}\tilde{w} + 0, 5\varepsilon\tilde{w}_\eta^2 + \nu(\tilde{u}_\xi - \varepsilon_{10}\tilde{w} + 0.5\varepsilon\tilde{w}_\xi^2)], \\ \tilde{F}_{\xi\eta} &= -\frac{1}{2(1+\nu)}(\tilde{u}_\eta + \tilde{v}_\xi + \varepsilon\tilde{w}_\xi\tilde{w}_\eta). \end{aligned} \quad (1.336)$$

Here $\tau = \sqrt{\frac{\rho(1-\nu^2)}{E}}at$, $\nabla_k \equiv \varepsilon_{20}\frac{\partial^2}{\partial\xi^2} + \varepsilon_{10}\frac{\partial^2}{\partial\eta^2}$, $\varepsilon = \frac{h}{a}$, $\varepsilon_{i0} = \frac{a}{R_i}$, $\{\xi, \eta\} = \frac{1}{a}\{x, y\}$, $\tilde{F} = \frac{F}{Eha}$, $\{\tilde{u}, \tilde{v}, \tilde{w}\} = \frac{1}{h}\{u, v, w\}$, F is the Airy function.

Let us introduce the fast variable $\varepsilon^\alpha\theta(\xi, \eta)$ (parameter $\alpha < 0$ will be further estimated), and therefore

$$\frac{\partial}{\partial\xi} = \frac{\partial}{\partial\xi} + \varepsilon^\alpha\theta_\xi\frac{\partial}{\partial\theta}, \quad \frac{\partial}{\partial\eta} = \frac{\partial}{\partial\eta} + \varepsilon^\alpha\theta_\eta\frac{\partial}{\partial\theta}.$$

Displacement and Airy functions are being sought in the series forms of a slow and fast components, where the latter ones treated as periodic regarding θ of a period T , follow:

$$\begin{aligned} \tilde{F} &= F^0(\xi, \eta, \tau) + \varepsilon^{\beta_1}F^1(\xi, \eta, \varepsilon^\alpha\theta, \tau), & \tilde{w} &= w^0(\xi, \eta, \tau) + \varepsilon^{\beta_2}w^1(\xi, \eta, \varepsilon^\alpha\theta, \tau), \\ \tilde{u} &= u^0(\xi, \eta, \tau) + \varepsilon^{\beta_3}u^1(\xi, \eta, \varepsilon^\alpha\theta, \tau), & \tilde{v} &= v^0(\xi, \eta, \tau) + \varepsilon^{\beta_4}v^1(\xi, \eta, \varepsilon^\alpha\theta, \tau). \end{aligned}$$

Let us also introduce parameters of asymptotic integrations γ_i and δ with the following scaling:

$$F^0 \sim \varepsilon^{\gamma_1}w^0, \quad w^0 \sim \varepsilon^{\gamma_2}, \quad u^0 \sim \varepsilon^{\gamma_3}, \quad v^0 \sim \varepsilon^{\gamma_4}, \quad \frac{\partial}{\partial\tau}(\dots) \sim \varepsilon^\delta(\dots).$$

We carry out the asymptotic analysis of systems (1.335), (1.336) assuming $\varepsilon_{10} \sim \varepsilon_{20} \sim 1$. As a result, we obtain the following estimations for the parameters $\alpha, \beta_i, \gamma_i, \delta$: $\alpha = -0, 5$, $\beta_1 = 0$, $\beta_2 < 0$, $\beta_3 \geq 0$, $\beta_4 \geq -0, 5$, $\gamma_1 = 1$, $\gamma_2 = 0$, $\gamma_3 > 0$, $\gamma_4 > 0$, $\delta = 0$.

The corresponding limiting system is

$$\begin{aligned} \frac{1}{12(1-\nu^2)}w_{\theta\theta\theta\theta}^1(\theta_\xi^2 + \theta_\eta^2) - (\varepsilon_{20}\theta_\xi^2 + \varepsilon_{10}\theta_\eta^2)F_{\theta\theta}^1 - \\ (F_{\xi\xi}^0\theta_\eta^2 + 2F_{\xi\eta}^0\theta_\xi\theta_\eta + F_{\eta\eta}^0\theta_\xi^2)w_{\theta\theta}^1 + w_{\tau\tau}^1 = 0, \end{aligned} \quad (1.337)$$

$$F_{\theta\theta\theta\theta}^1(\theta_\xi^2 + \theta_\eta^2)^2 - (\varepsilon_{20}\theta_\xi^2 + \varepsilon_{10}\theta_\eta^2)w_{\theta\theta}^1 = 0, \quad (1.338)$$

$$\varepsilon^{-1} F_{\theta\theta}^1 \theta_\xi \theta_\eta + F_{\eta\eta}^0 = \frac{1}{2(1-\nu^2)} (w_\theta^1)^2 \theta_\xi \theta_\eta, \quad (1.339)$$

$$\varepsilon^{-1} F_{\theta\theta}^1 \theta_\xi \theta_\eta + F_{\xi\xi}^0 = \frac{1}{2(1-\nu^2)} (w_\theta^1)^2 \theta_\xi \theta_\eta, \quad (1.340)$$

$$\varepsilon^{-1} F_{\theta\theta}^1 \theta_\xi \theta_\eta + F_{\xi\eta}^0 = -\frac{1}{2(1+\nu)} (w_\theta^1)^2 \theta_\xi \theta_\eta. \quad (1.341)$$

Derivatives of F^0 appeared on Equation (1.337) are defined via Equations (1.339)–(1.341) after averaging with respect to θ . According to periodicity of function F_θ^1 , the following relation holds:

$$\int_0^T F_{\theta\theta}^1 d\theta = 0.$$

Finally, we get

$$\begin{aligned} -(F_{\xi\xi}^0 \theta_\eta^2 + 2F_{\xi\eta}^0 \theta_\xi \theta_\eta + F_{\eta\eta}^0 \theta_\xi^2) w_{\theta\theta}^1 &= \frac{1}{2(1-\nu^2)} \int_0^T [(w_\theta^1)^2 (\theta_\xi^2 + \theta_\eta^2)^2 - \\ &2w^1 [\varepsilon_{10} (\theta_\xi^2 + \nu \theta_\eta^2) + \varepsilon_{20} (\theta_\eta + \theta_\xi)]] d\theta. \end{aligned} \quad (1.342)$$

Taking into account relation (1.342), the following simplified equations are obtained:

$$\begin{aligned} \frac{D}{h} \nabla^4 w - \left(\frac{1}{R_2} \frac{\partial^2}{\partial x^2} + \frac{1}{R_1} \frac{\partial^2}{\partial y^2} \right) F - \frac{E}{ab(1-\nu^2)} \times \\ \left\{ 0.5 \nabla^2 w \int_a^b \int_a^b [w_x^2 + w_y^2] dx dy - w_{xx} \int_0^a \int_0^b \left(\frac{\nu}{R_1} + \frac{1}{R_2} \right) w dy dx - \right. \\ \left. w_{yy} \int_0^a \int_0^b \left(\frac{1}{R_1} + \frac{\nu}{R_2} \right) w dy dx \right\} + \rho w_{tt} = 0, \end{aligned} \quad (1.343)$$

$$\frac{D}{h} \nabla^4 F - \left(\frac{1}{R_2} \frac{\partial^2}{\partial x^2} + \frac{1}{R_1} \frac{\partial^2}{\partial y^2} \right) w = 0. \quad (1.344)$$

Observe that for $R_1 \rightarrow \infty$, $R_2 \rightarrow \infty$ Equation (1.343) transits into Berger equation, and in the one-dimensional case we obtain the Kirchhoff equation.

1.8.5 Differential Equations with Quickly Changing Coefficients

In what follows we introduce the homogenization method using the following simple 1D problem [46], [138], [139], [140], [148], [169]:

$$\frac{d}{dx} \left[a \left(\frac{x}{\varepsilon} \right) \frac{du}{dx} \right] = q(x), \quad (1.345)$$

$$u = 0 \quad \text{for } x = 0, L. \quad (1.346)$$

Here $a(x/\varepsilon)$ is periodic with respect to x , and has the period ε .

Variation of the r.h.s. of Equation (1.345) is small, but the coefficient $a(x/\varepsilon)$ changes quickly. Therefore, one may apply the method of two scales, and introduce fast $\eta = x/\varepsilon$ and slow $y = x$ variables. Then, the derivative follows:

$$\frac{d}{dx} = \frac{\partial}{\partial y} + \varepsilon^{-1} \frac{\partial}{\partial \eta}, \quad (1.347)$$

and instead of the input ODE we get a PDE.

Its solution is assumed to have the following form:

$$u = u_0(\eta, y) + \varepsilon u_1(\eta, y) + \dots, \quad (1.348)$$

where u_0, u_1, \dots are periodic functions with respect to η of period 1.

Substituting relations (1.347), (1.348) into input Equation (1.345) and BCs (1.346), and comparing the terms standing by the same powers of ε , the following recurrent system of equations is obtained

$$\frac{\partial}{\partial \eta} \left[a(\eta) \frac{\partial u_0}{\partial \eta} \right] = 0, \quad (1.349)$$

$$\frac{\partial}{\partial \eta} \left[a(\eta) \frac{\partial u_0}{\partial y} \right] + a(\eta) \frac{\partial^2 u_0}{\partial y \partial \eta} + \frac{\partial}{\partial \eta} \left[a(\eta) \frac{\partial u_1}{\partial \eta} \right] = 0, \quad (1.350)$$

$$\frac{\partial}{\partial \eta} \left[a(\eta) \frac{\partial u_2}{\partial \eta} \right] + a(\eta) \frac{\partial^2 u_0}{\partial y^2} + \frac{\partial}{\partial \eta} \left[a(\eta) \frac{\partial u_1}{\partial y} \right] + a(\eta) \frac{\partial^2 u_1}{\partial y \partial \eta} = q(y), \quad (1.351)$$

.....

$$u_j = 0 \quad \text{for } y = 0, L, \quad \eta = 0, L/\varepsilon, \quad j = 1, 2, 3, \dots \quad (1.352)$$

Equation (1.349), according to periodicity of functions u_0 with respect to η , yields $u_0 = u_0(y)$. It means that u_0 stands for a certain averaged part of function u and does not depend on a fast variable. In a series of physical problems, the existence of averaged part is already implied from the problem statement, and hence the first term of series (1.348) can be treated as not dependent on the fast variable. Equation (1.350) takes the following form

$$\frac{\partial}{\partial \eta} \left[a(\eta) \frac{\partial u_1}{\partial \eta} \right] = -\frac{\partial a(\eta)}{\partial \eta} \frac{du_0}{dy}. \quad (1.353)$$

This equation is considered on the period ($0 \leq \eta \leq 1$) and hence it is referred to as a cell or local governing equation. Solution to one cell problem is essentially simpler in comparison to the whole space solution. In this case we obtain

$$\frac{\partial u_1}{\partial \eta} = -\frac{\partial u_0}{\partial y} + \frac{C(y)}{a}. \quad (1.354)$$

Periodicity conditions of the first improvement term to the homogenized solution $u_1|_0^1 = 0$ allows us to determine the constant $C(y)$:

$$C = \hat{a} \frac{du_0}{dy}, \quad \hat{a} = \left[\int_0^1 a^{-1} d\eta \right]^{-1}.$$

Excluding $\partial u_1 / \partial \eta$ from (1.351) yields

$$\frac{\partial}{\partial \eta} \left(a \frac{\partial u_2}{\partial \eta} \right) + \frac{\partial}{\partial \eta} \left(a \frac{\partial u_1}{\partial y} \right) + \hat{a} \frac{d^2 u_0}{dy^2} = q(y). \quad (1.355)$$

Now, in order to withdraw slow components from Equation (1.355), we apply the homogenization procedure acting on each equation term by the averaging operator $\int_0^1 (\dots) d\eta$. First two terms, in result of averaging, are equal to zero due to the periodicity condition, and hence Equation (1.355) takes the form

$$\hat{a} \frac{d^2 u_0}{dy^2} = q(y). \quad (1.356)$$

We apply the following BCs for Equation (1.356):

$$u_0 = 0 \quad \text{for } y = 0, L. \quad (1.357)$$

In what follows we define the functions u_1 from conditions (1.354) :

$$u_1 = \frac{du_0}{dy} \left(\hat{a} \int_0^1 a^{-1} d\eta - \eta \right), 0 \leq \eta \leq 1.$$

Further, function u_1 is periodically extended with respect to coordinates with the period of 1. The found value u_1 does not satisfy, in general, BCs (1.346), and the associated errors are of the order ε . In order to remove them, the following problem is solved:

$$\frac{d}{dx} \left[a \left(\frac{x}{\varepsilon} \right) \frac{du}{dx} \right] = 0, \\ u|_{x=0} = A = u_1|_{y=\eta=0}, u|_{x=L} = B = u_1|_{y=L, \eta=L/\varepsilon}.$$

Applying to this problem the homogenization approach again, the following first approximation is obtained:

$$\hat{a} \frac{d^2 u_{01}}{dy^2} = 0, u_{01}|_{y=0} = A, u_{01}|_{y=L} = B.$$

It is then tempting to apply the following solutions form:

$$u = u_0(y) + \varepsilon[u_{01}(y) + \varepsilon u_{02}(y) + \varepsilon^2 u_{03}(y) + \dots] + \\ \varepsilon[u_1(\eta, y) + \varepsilon u_2(\eta, y) + \varepsilon^2 u_3(\eta, y) + \dots]. \quad (1.358)$$

where $u_i(\eta, y)$ are a function having averaged values with respect to a period equal to zero.

Let us consider one more example of the following nonlinear equation:

$$\frac{d}{dx} \left[a \left(\frac{x}{\varepsilon} \right) \frac{du}{dx} \right] + b \left(\frac{x}{\varepsilon} \right) u^3 = q(x), \quad (1.359)$$

$$u = 0 \quad \text{for } x = 0, L. \quad (1.360)$$

Introducing the fast and slow variables η and y , and approximating the function u in the form (1.348), the following recurrent relations are obtained:

$$\frac{\partial}{\partial \eta} \left[a(\eta) \frac{\partial u_1}{\partial \eta} \right] + \frac{da(\eta)}{d\eta} \frac{du_0}{dy} = 0, \quad (1.361)$$

$$\frac{\partial}{\partial \eta} \left[a(\eta) \frac{\partial u_2}{\partial \eta} \right] + \frac{\partial}{\partial \eta} \left[a(\eta) \frac{\partial u_1}{\partial y} \right] + a(\eta) \frac{\partial^2 u_1}{\partial y \partial \eta} + a(\eta) \frac{d^2 u_0}{dy^2} + b(\eta) u_0^3 = q(y), \tag{1.362}$$

.....

$$u_0 = 0 \quad \text{for } y = 0, l,$$

$$u_1 = 0 \quad \text{for } y = 0, l, \quad \eta = 0, L/\varepsilon, \tag{1.363}$$

.....

Equation (1.361) coincides with Equation (1.350), and the local problem is not changed, when new terms are added without a change of higher order derivatives. Using the solution (1.354), the following homogenized equation is derived:

$$\hat{a} \frac{d^2 u_0}{dy^2} + \hat{b} u^3 = q(y), \quad \hat{b} = \int_0^1 b(\eta) d\eta. \tag{1.364}$$

BCs for Equation (1.364) have the form (1.363). It should be emphasized that

$$u = u_0 + O(\varepsilon), \quad \text{but } \frac{du}{dx} = \frac{du_0}{dy} + \frac{\partial u_1}{\partial \eta} + O(\varepsilon).$$

In other words, although the solution u_0 to the homogenized equation approximates the function u with accuracy up to the terms of order ε , in the relations for the derivative one has to keep terms with u_1 . Their occurrence generates problems in the process of numerical computations of the solution due to errors introduced by differentiations.

Let us now discuss the physical aspects of the coefficients of the homogenized Equation (1.364). It is clear that both coefficients b and $1/a$ are averaged. Sometimes averaging of the stiffness is referred to as Voigt averaging [60], [252], whereas the averaging of compliance is called Reuss averaging [60], [210]. These estimations present averaged arithmetic and averaged harmonic characteristics of the matrices and inclusions for composites. For a wide range of problems true values of the averaged coefficients of the homogenized Equation (1.364) \hat{a}_{ij} are located in between the averaged coefficients of Voigt (\bar{a}_{ij}) and Reuss (\hat{a}_{ij}):

$$\hat{a}_{ij} \leq \tilde{a}_{ij} \leq \bar{a}_{ij}. \tag{1.365}$$

Estimation (1.365) is known as the Voigt-Reuss pitchfork or Hill pitchfork, although it has been obtained first by Wiener [259]. However, the interval estimated in the mentioned pitchfork is relatively large.

In Figure 1.19, as an example, results obtained via computation of the homogenized conductivity d of the composite material composed of the matrices and square inclusions are reported. Input problem is governed by Laplace equations associated with a periodically nonhomogeneous medium.

A cell of periodicity presents a square of the side 1, whereas inclusions of the size $1/3$ are located symmetrically with respect to the square center, whereas the ratio of conductivities of the matrix and inclusion is denoted by d_0 . Dotted (dashed) curve corresponds to Voigt's (Reuss) estimation. Solid curve corresponds to results of homogenization using numerical solution to

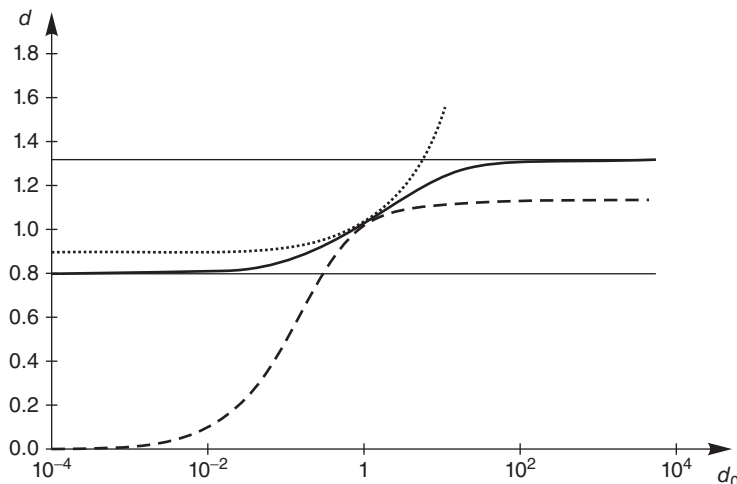

Figure 1.19 Results of homogenization of Laplace equation associated with a periodically nonhomogenous medium, with the Voigt (dot curve) and Reuss (dashed) curve estimation

the problem on a cell [32], [63]. Figure 5.1 gives insight into application of estimation (1.365) with respect to practical problems.

Let us consider now the eigenvalue problem

$$\frac{d}{dx} \left[a \left(\frac{x}{\varepsilon} \right) \frac{du}{dx} \right] + \lambda u = 0, \tag{1.366}$$

$$u = 0 \quad \text{for } x = 0, L.$$

We present the eigenform in the form of (1.358), and the eigenvalue λ is presented by the series

$$\lambda = \lambda_0 + \varepsilon \lambda_1 + \varepsilon^2 \lambda_2 + \dots \tag{1.367}$$

Substituting series (1.358), (1.367) into the input BVP (1.366) and taking into account formulas for the derivative (1.347), the following recurrent set of equations is obtained

$$\frac{\partial a}{\partial \eta} \frac{du_0}{dy} + \frac{\partial}{\partial \eta} \left[a \frac{\partial u_1}{\partial \eta} \right] = 0, \tag{1.368}$$

$$\begin{aligned} & \frac{\partial}{\partial \eta} \left(a \frac{\partial u_2}{\partial \eta} \right) + \frac{\partial}{\partial \eta} \left(a \frac{\partial u_1}{\partial y} \right) + \\ & a \frac{\partial^2 u_1}{\partial y \partial \eta} + \frac{\partial a}{\partial \eta} \frac{du_{01}}{dy} + a \frac{d^2 u_0}{dy^2} + \lambda_0 u_0 = 0, \end{aligned} \tag{1.369}$$

$$\begin{aligned} & \frac{\partial}{\partial \eta} \left(a \frac{\partial u_3}{\partial \eta} \right) + \frac{\partial}{\partial \eta} \left(a \frac{\partial u_2}{\partial \eta} \right) + \frac{\partial a}{\partial \eta} \frac{du_{02}}{dy} + \\ & a \frac{\partial^2 u_2}{\partial y \partial \eta} + a \frac{d^2 u_{01}}{dy^2} + \lambda_1 u_0 + \lambda_0 (u_{01} + u_1) = 0, \end{aligned} \tag{1.370}$$

... ..

$$u_0 = 0 \quad \text{for } y = 0, L, \tag{1.371}$$

$$u_1 + u_{01} = 0 \quad \text{for } \eta = 0, L/\varepsilon, \tag{1.372}$$

... ..

The yielded value $\partial u_1 / \partial \eta$ by Equation (1.368) is substituted into Equation (1.369) and into BCs (1.371), and after averaging the following BVP with respect to u_0 , λ_0 is defined:

$$\hat{a} \frac{d^2 u_0}{dy^2} + \lambda_0 u_0 = 0, \quad u_0 = 0 \quad \text{for } y = 0, L.$$

Now, Equation (1.369) yields

$$\frac{\partial u_2}{\partial \eta} = -\frac{\partial u_1}{\partial y} - \frac{du_{01}}{dy} + \frac{C_1(y)}{a}.$$

Due to periodicity condition of the function u_2 with respect to η , we get

$$C_1 = \hat{a} \frac{du_{01}}{dy} + \hat{a} \frac{\partial \hat{u}_1}{\partial y}, \quad \text{for } \hat{u}_1 = \int_0^1 u_1 d\eta.$$

Substituting the already found values u_1 , u_2 into Equation (1.370), and applying the averaging procedure, we obtain

$$\hat{a} \frac{d^2 u_{01}}{dy^2} + \lambda_0 u_{01} + \hat{a} \frac{\partial^2 \hat{u}_1}{\partial y^2} + \lambda_0 \hat{u}_1 + \lambda_1 u_0 = 0. \tag{1.373}$$

BC for Equations (1.373) are obtained from BCs (1.372), and they have the following form:

$$u_{01} = -\hat{u}_1 \quad \text{for } y = 0, L. \tag{1.374}$$

Improvement term to frequency λ_1 is defined via perturbation method, and then the slow improving term to the homogenized solution u_{01} is yielded by a solution to the BVPs (1.373), (1.374).

The approach described so far allows us to determine a solution in an arbitrary approximation regarding ε . Its most attractive advantage is generality. Indeed, having found a solution to a local problem, one may also define a solution to the input problem, as well as solve the eigenvalue problem. If one adds into the equation nonlinear terms in a way not disturbing higher order derivatives, then a construction of homogenized relations can be carried out in the similar way. The local problem remains the same as in the linear case, as well as the higher order approximations being linear. The whole nonlinearity is located in homogenized BVPs with smooth coefficients, which can be easily solved either via numerical or variational methods.

1.8.6 Differential Equation with Periodically Discontinuous Coefficients

We consider an application of the homogenization method to solve problems of DEs with periodically discontinuous coefficients. They are also known as problems with periodic barriers [251]. As an example we consider deformation of a membrane reinforced by threads.

Equations of equilibrium in intervals $kl < y_1 < (k+1)l$ are formulated as follows

$$\frac{\partial^2 u}{\partial x_1^2} + \frac{\partial^2 u}{\partial y_1^2} = Q(x_1, y_1). \quad (1.375)$$

Condition of linking neighborhood parts, being also known as the matching of jump conditions [251], have the following form

$$\lim_{y_1 \rightarrow kl+0} u \equiv u^+ = \lim_{y_1 \rightarrow kl-0} u \equiv u^-, \quad k = 0, \pm 1, \pm 2, \dots, \\ \left(\frac{\partial u}{\partial y_1} \right)^+ - \left(\frac{\partial u}{\partial y_1} \right)^- = p \frac{\partial^2 u}{\partial x_1^2}, \quad (1.376)$$

where p is the parameter characterizing relative thread stiffness.

BCs for $x_1 = 0, H$ follow

$$u = 0. \quad (1.377)$$

Let us assume, that an external load is periodic with respect to y_1 , and its period L is essentially larger than the distance between threads. Then, one may apply homogenization approach by taking $\varepsilon = l/L$ as the perturbation/small parameter. Introducing, instead of y_1 , fast ($\eta = y_1/l$) and slow ($y = y_1/L$) variables yields

$$\frac{\partial}{\partial y_1} = \frac{1}{L} \left(\frac{\partial}{\partial y} + \varepsilon^{-1} \frac{\partial}{\partial \eta} \right). \quad (1.378)$$

Function u is approximated by the series

$$u = u_0(x, y) + \varepsilon^\alpha [u_{01}(x, y) + u_1(x, y, \eta)] + \\ \varepsilon^{\alpha_1} [u_{02}(x, y) + u_2(x, y, \eta)] + \dots, \quad (1.379)$$

where $0 < \alpha < \alpha_1 < \dots$, $x = x_1/L$.

Substituting Ansatz (1.379) into Equation (1.375) and into condition (1.376), and taking into account the formula (1.378), we get

$$\nabla^2 u_0 + \varepsilon^{\alpha-2} \frac{\partial^2 u_1}{\partial \eta^2} + 2\varepsilon^{\alpha-1} \frac{\partial^2 u_1}{\partial y \partial \eta} + \varepsilon^{\alpha-2} \frac{\partial^2 u_2}{\partial \eta^2} + \\ 2\varepsilon^{\alpha-1} \frac{\partial^2 u_2}{\partial y \partial \eta} + O(\varepsilon^\alpha) = q(x, y), \quad (1.380)$$

$$[u_0 + \varepsilon^\alpha (u_{01} + u_1) + \dots]^+ = [u_0 + \varepsilon^\alpha (u_{01} + u_1) + \dots]^-, \quad (1.381)$$

$$\varepsilon^{\alpha-1} \left[\left(\frac{\partial u_1}{\partial \eta} \right)^+ - \left(\frac{\partial u_1}{\partial \eta} \right)^- \right] + O(\varepsilon^\alpha) = p_1 \left[\frac{\partial^2 u_0}{\partial x^2} + O(\varepsilon^\alpha) \right],$$

where $q = L^2 Q$, $p_1 = p/L$, $\nabla^2 u_0 = \frac{\partial^2 u_0}{\partial x^2} + \frac{\partial^2 u_0}{\partial y^2}$, $(\dots)^\pm = \lim_{\eta \rightarrow k \pm 0} u$.

It should be emphasized that a majority of the works devoted to homogenization of periodic systems, in particular those purely mathematical, are carried out using the following implicit statements: the occurred system parameters are of the same order. However, in our case a way

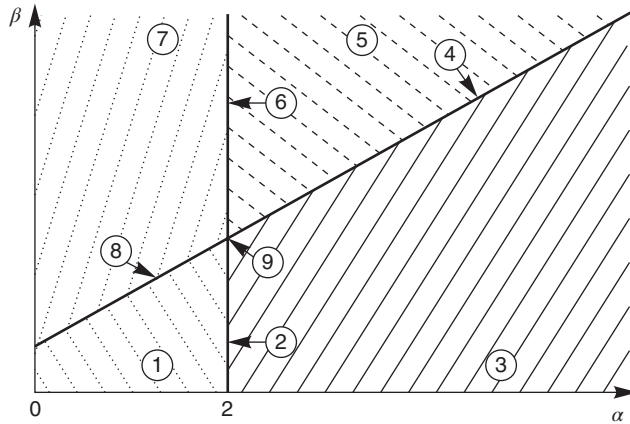

Figure 1.20 Partition of the parameter quadrant plane into nine zones with different asymptotics

of construction of asymptotics essentially depends on the order of the relative thread stiffness p_1 in comparison to parameter ϵ . In what follows we introduce the parameter β characterizing this order ($p_1 \sim \epsilon^\beta$) and we study a possible character of limiting systems depending on α, β .

Owing to Equation (1.380), the following different limiting system occurs for $0 < \alpha < 2$, $\alpha = 2$ and $\alpha > 2$:

$$\text{for } 0 < \alpha < 2 \quad \frac{\partial^2 u_1}{\partial \eta^2} = 0, \tag{1.382}$$

$$\text{for } \alpha = 2 \quad \nabla^2 u_0 + \frac{\partial^2 u_1}{\partial \eta^2} = q, \tag{1.383}$$

$$\text{for } \alpha > 2 \quad \nabla^2 u_0 = q. \tag{1.384}$$

Limiting relations are obtained from relation (1.381) for $\epsilon \rightarrow 0$, and they have the following form

$$\text{for } \beta < \alpha - 1 \quad \frac{\partial^2 u_0}{\partial x^2} = 0, \tag{1.385}$$

$$\text{for } \beta = \alpha - 1 \quad \left(\frac{\partial u_1}{\partial \eta}\right)^+ - \left(\frac{\partial u_1}{\partial \eta}\right)^- = p_1 \epsilon^{1-\alpha} \frac{\partial^2 u_0}{\partial x^2}, \tag{1.386}$$

$$\text{for } \beta > \alpha - 1 \quad \left(\frac{\partial u_1}{\partial \eta}\right)^+ = \left(\frac{\partial u_1}{\partial \eta}\right)^-. \tag{1.387}$$

The quadrant plane of the parameters $\beta > 0, \alpha > 0$ have nine different areas (Figure 1.20).

In what follows we are going to study them in some detail. Let $\beta < \alpha - 1$, which means physically that the threads are stiff. Equation (1.385) yields $u_0 = 0$ and hence we cannot apply the homogenization approach here. For zones 1–3, we have the following governing limiting equation

$$\frac{\partial^2 u_1}{\partial \eta^2} = q. \tag{1.388}$$

The case $\beta > \alpha - 1$, corresponds to zones 4–6. Physically it means that we deal with weak threads, and the limiting case is governed by (1.384).

Zones 7 and 8 are described by equations out of the physical meaning. A key role plays zone 9 ($\alpha = 2, \beta = 1$) associated with averaged thread stiffness. The limiting system is composed of Equations (1.383), (1.386), and the transition conditions take the form

$$u_1^+ = u_1^-, \quad (1.389)$$

$$\left(\frac{\partial u_1}{\partial \eta}\right)^+ - \left(\frac{\partial u_1}{\partial \eta}\right)^- = p_2 \frac{\partial^2 u_0}{\partial x^2}, \quad (1.390)$$

where $p_2 = p/l$.

Equation (1.382) implies

$$u_1 = 0, 5(q - \nabla^2 u_0)\eta^2 + C(x, y)\eta + C_1(x, y).$$

Constant $C_1(x, y)$ is associated with the term u_{01} , which is defined through homogenized equation of the successive approximations. Conditions (1.389) yield

$$C(x, y) = -0, 5(q - \nabla^2 u_0) L. \quad (1.391)$$

We have to satisfy one more condition (1.390), but there is a lack of constants. However, condition (1.390) implies the looked for homogenization equation. Indeed, substituting the found value u_1 into Equation (1.390), we obtain

$$\nabla^2 u_0 + p_2 \frac{\partial^2 u_0}{\partial x^2} = q. \quad (1.392)$$

Equation (1.392) should be integrated taking into account the following BCs:

$$u_0 = 0 \quad \text{for } x = 0, H/L.$$

Physically, a transition into Equation (1.392) is associated with a “smeared” of the threads stiffness (transition into structurally-orthotropic theory). Finally, function u_1 can be approximated in the following way:

$$u_1 = 0.5p_2 \frac{\partial^2 u_0}{\partial x^2} \eta(\eta - 1).$$

In general, BCs are not satisfied. Boundary error quickly changes with respect to η , and yields occurrence of a boundary layer u_b . We construct the latter through introduction of the variable $\xi = x_1/l$ via the following series:

$$u_b = \varepsilon^{\gamma_1} u_{b1}(x, y, \xi, \eta) + \varepsilon^{\gamma_2} u_{b2}(x, y, \xi, \eta) + \dots,$$

where $0 < \gamma_1 < \gamma_2 < \dots$

Equations yielding the function u_{b1} have the following form:

$$\frac{\partial^2 u_{b1}}{\partial \xi^2} + \frac{\partial^2 u_{b1}}{\partial \eta^2} = 0,$$

$$u_{b1}|_{\eta=k} = 0, \quad k = 0, \pm 1, \dots$$

BCs (we consider only one edge) for $x = \xi = 0$ have the following form:

$$u_{b1} = -u_1.$$

In order to construct boundary layer, one may apply the Kantorovich method, taking u_{b1} in the following form:

$$u_{b1} = \Phi(\xi)\eta(\eta - 1).$$

and now the boundary conditions $\eta = 0, 1$ are satisfied. Furthermore, the standard Kantorovich technique can be applied [142].

Let us now describe more rigorously the notion of fast and slow changes of the load. Function $f(\varepsilon, \theta)$ is called oscillating with velocity ε^{-1} on the period 2π , if [251]

$$0 < C_1 \leq \int_0^{2\pi} |f(\varepsilon, \theta)|^2 d\theta \leq C_2 < \infty, \quad \left| \int_0^\alpha f(\varepsilon, \theta) d\theta \right| \leq C\varepsilon, \quad 0 \leq \alpha \leq 2\pi,$$

where C, C_1, C_2 are certain constants.

1.8.7 Periodically Perforated Domain

We consider the Poisson equation, which describes membrane deformation

$$\nabla^2 u = f(x, y) \tag{1.393}$$

in the multi-connected domain Ω (Figure 1.21) [122], [123]. Small parameter ε characterizes a ratio of the characteristics size of the repeated part (cell) and the characteristic domain dimension.

On the boundary of holes Neuman BCs are given

$$\frac{\partial u}{\partial \mathbf{n}_i} = 0 \quad \text{on} \quad \partial\Omega_i, \tag{1.394}$$

where \mathbf{n}_i denotes an external normal to the contour of i -th hole.

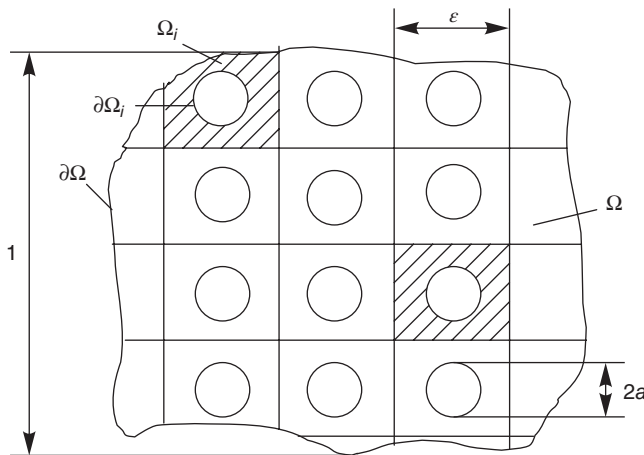

Figure 1.21 Perforated medium

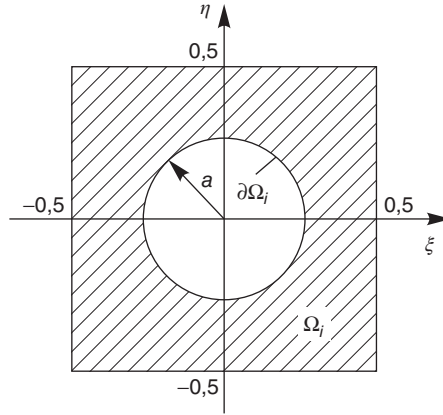

Figure 1.22 Periodically repeated cell

Membrane edges are clamped

$$u = 0 \quad \text{on} \quad \partial\Omega. \tag{1.395}$$

We introduce fast variables $\xi = x/\epsilon, \eta = y/\epsilon$. The solution is assumed to be of the form

$$u = u_0(x, y) + \epsilon u_1(x, y, \xi, \eta) + \epsilon^2 u_2(x, y, \xi, \eta) + \dots, \tag{1.396}$$

where u_j ($j = 1, 2, \dots$) are periodic functions with period 1 with respect to ξ, η .

Partial derivatives follow:

$$\frac{\partial}{\partial x} = \frac{\partial}{\partial x} + \epsilon^{-1} \frac{\partial}{\partial \xi}, \quad \frac{\partial}{\partial y} = \frac{\partial}{\partial y} + \epsilon^{-1} \frac{\partial}{\partial \eta}. \tag{1.397}$$

A periodically repeated cell in fast variables is shown in Figure 1.22.

Substituting Ansatz (1.396) into BVP (1.393)–(1.395), and taking into account Equations (1.397), the splitting procedure with respect to ϵ yields the following recurrent sequence of the BVPs:

$$\frac{\partial^2 u_1}{\partial \xi^2} + \frac{\partial^2 u_1}{\partial \eta^2} = 0 \quad \text{in} \quad \Omega_i, \tag{1.398}$$

$$\frac{\partial u_1}{\partial \mathbf{k}} + \frac{\partial u_0}{\partial \mathbf{n}} = 0 \quad \text{on} \quad \partial\Omega_i, \tag{1.399}$$

$$\frac{\partial^2 u_0}{\partial x^2} + \frac{\partial^2 u_0}{\partial y^2} + 2 \left(\frac{\partial^2 u_1}{\partial x \partial \xi} + \frac{\partial^2 u_1}{\partial y \partial \eta} \right) + \frac{\partial^2 u_2}{\partial \xi^2} + \frac{\partial^2 u_2}{\partial \eta^2} = f \quad \text{in} \quad \Omega_i, \tag{1.400}$$

$$\frac{\partial u_2}{\partial \mathbf{k}} + \frac{\partial u_1}{\partial \mathbf{n}} = 0 \quad \text{on} \quad \partial\Omega_i, \tag{1.401}$$

.....

$$u_i = 0, \quad i = 0, 1, 2, \dots \quad \text{on} \quad \partial\Omega. \tag{1.402}$$

Here \mathbf{k} denotes a normal to the hole contour in fast variables.

We define the averaging operator in the following way:

$$\bar{\Phi}(x, y) = \iint_{\Omega_i} \Phi(x, y, \xi, \eta) d\xi d\eta. \quad (1.403)$$

After application of the averaging operator (1.256), Equation (1.400) yields

$$\left(\frac{\partial^2 u_0}{\partial x^2} + \frac{\partial^2 u_0}{\partial y^2} \right) (1 - \pi a^2) + \iint_{\Omega_i} \left(\frac{\partial^2 u_1}{\partial x \partial \xi} + \frac{\partial^2 u_1}{\partial y \partial \eta} \right) d\xi d\eta = (1 - \pi a^2)f. \quad (1.404)$$

Homogenized BC takes the following form

$$u_0 = 0 \quad \text{on } \partial\Omega. \quad (1.405)$$

Now we proceed to the problem on cell (1.398), (1.399) taking into account the condition of a periodic continuation, i.e. conditions of equality of the function u_1 and its first order derivatives regarding the respective coordinates lying on contrary located cell sides are satisfied.

Reduction of the periodic problems to those of BVPs has been described, for instance in monograph ([32], chapter 6). In both cases displacements on two contrary located external cell boundaries as well as normal derivatives on two remaining sides are equal zero.

Assume that the opening diameter $2a$ is small in comparison to the cell dimensions. In the first approximation u_1 ($u_1 \approx u_1^{(1)}$), one may transit into the infinite plane problem of the opening

$$\frac{\partial^2 u_1^{(1)}}{\partial \xi^2} + \frac{\partial^2 u_1^{(1)}}{\partial \eta^2} = 0, \quad (1.406)$$

$$\frac{\partial u_1^{(1)}}{\partial \mathbf{k}} + \frac{\partial u_0}{\partial \mathbf{n}} = 0 \quad \text{on } \partial\Omega_i, \quad (1.407)$$

$$u_1^{(1)} \rightarrow 0 \quad \text{for } \xi^2 + \eta^2 \rightarrow \infty. \quad (1.408)$$

In polar coordinates the BVP (1.406)–(1.408) can be cast into the following form

$$\frac{\partial^2 u_1^{(1)}}{\partial r^2} + \frac{1}{r} \frac{\partial u_1^{(1)}}{\partial r} + \frac{1}{r^2} \frac{\partial^2 u_1^{(1)}}{\partial \theta^2} = 0, \quad (1.409)$$

$$\left. \frac{\partial u_1^{(1)}}{\partial r} \right|_{r=a} = -\frac{\partial u_0}{\partial x} \cos \theta - \frac{\partial u_0}{\partial y} \sin \theta, \quad (1.410)$$

$$u_1^{(1)} \rightarrow 0 \quad \text{for } r \rightarrow \infty. \quad (1.411)$$

A solution to the BVP (1.409)–(1.411) is

$$u_1^{(1)} = \frac{a^2}{r} \left(\frac{\partial u_0}{\partial x} \cos \theta + \frac{\partial u_0}{\partial y} \sin \theta \right). \quad (1.412)$$

Observe that functions $u_1^{(1)}$ do not satisfy the periodicity conditions. In order to avoid compensating the discrepancy, we obtain in the second approximation ($u_1 \approx u_1^{(1)} + u_1^{(2)}$) the following BVP:

$$\Delta u_1^{(2)} = 0 \quad \text{in } \Omega_i^*,$$

$$u_1^{(2)}(0, 5, \eta) - u_1^{(2)}(-0, 5, \eta) = u_1^{(1)}(-0, 5, \eta) - u_1^{(1)}(0, 5, \eta),$$

$$\begin{aligned} u_1^{(2)}(\xi, 0, 5) - u_1^{(2)}(\xi, -0, 5) &= u_1^{(1)}(\xi, -0, 5) - u_1^{(1)}(\xi, 0, 5), \\ u_{1\xi}^{(2)}(0, 5, \eta) - u_{1\xi}^{(2)}(-0, 5, \eta) &= u_{1\xi}^{(1)}(-0, 5, \eta) - u_{1\xi}^{(1)}(0, 5, \eta), \\ u_{1\eta}^{(2)}(\xi, 0, 5) - u_{1\eta}^{(2)}(\xi, -0, 5) &= u_{1\eta}^{(1)}(\xi, -0, 5) - u_{1\eta}^{(1)}(\xi, 0, 5). \end{aligned}$$

Let us present $u_1^{(2)}$ in the form

$$u_1^{(2)} = u_1^{(12)} + u_1^{(22)}, \quad (1.413)$$

where functions $u_1^{(12)}$ satisfy homogenous BCs with respect to ξ and nonhomogenous ones with respect to η . The function $u_1^{(22)}$ can be obtained from $u_1^{(12)}$ via change of the variables ($\xi \leftrightarrow \eta, x \leftrightarrow y$).

The following BVP for $u_1^{(12)}$ estimation is obtained:

$$\Delta u_1^{(12)} = 0 \text{ in } \Omega_i^*, \quad (1.414)$$

$$u_1^{(12)}(0, 5, \eta) = u_1^{(12)}(-0, 5, \eta), u_{1\xi}^{(12)}(0, 5, \eta) = u_{1\xi}^{(12)}(-0, 5, \eta), \quad (1.415)$$

$$u_1^{(12)}(\xi, 0, 5) - u_1^{(12)}(\xi, -0, 5) = u_1^{(1)}(\xi, -0, 5) - u_1^{(1)}(\xi, 0, 5), \quad (1.416)$$

$$u_{1\eta}^{(12)}(\xi, 0, 5) - u_{1\eta}^{(12)}(\xi, -0, 5) = u_{1\eta}^{(1)}(\xi, -0, 5) - u_{1\eta}^{(1)}(\xi, 0, 5).$$

A general solution to Equation (1.414) takes the following form:

$$\begin{aligned} u_1^{(12)} &= A_0 + B_0\eta + \sum_{n=1}^{\infty} [(A_n \text{ch}(2\pi n\eta) + B_n \text{sh}(2\pi n\eta)) \cos(2\pi n\xi) + \\ &\quad (C_n \text{ch}(2\pi n\eta) + D_n \text{sh}(2\pi n\eta)) \sin(2\pi n\xi)], \end{aligned} \quad (1.417)$$

where A_n, B_n, C_n, D_n are arbitrary constants.

Let us present now BCs (1.416) in the following form:

$$u_1^{(12)}(\xi, 0, 5) - u_1^{(12)}(\xi, -0, 5) = -\frac{\partial u_0}{\partial y} a^2 (\xi^2 + 0, 25)^{-1}, \quad (1.418)$$

$$u_{1\eta}^{(12)}(\xi, 0, 5) - u_{1\eta}^{(12)}(\xi, -0, 5) = 2\frac{\partial u_0}{\partial x} a^2 \xi (\xi^2 + 0, 25)^{-2}. \quad (1.419)$$

Developing r.h.s. of relations (1.418), (1.419) into Fourier series and substituting solution (1.417) into Equations (1.418), (1.419), we obtain

$$A_n = D_n = 0, n = 0, 1, \dots, B_0 = -\frac{\partial u_0}{\partial y} \pi a^2 = \frac{\partial u_0}{\partial y} B_0^*,$$

$$B_n = -\frac{\partial u_0}{\partial y} \frac{2a^2}{\text{sh}\pi n} [e^{-\pi n} \text{Im}E_1(\pi n(i-1)) - e^{\pi n} \text{Im}E_1(\pi n(i+1))] = \frac{\partial u_0}{\partial y} B_n^*,$$

$$C_n = B_n \text{ including the change } \frac{\partial u_0}{\partial y} \Rightarrow \frac{\partial u_0}{\partial x}, n = 0, 1, 2, \dots$$

Here $E_1(\dots)$ denotes integral exponential function ([2], chapter 5), $i = \sqrt{-1}$.
Finally, we have

$$\bar{u}_1^{(2)} = \frac{\partial u_0}{\partial y} B_0^* \eta + \sum_{n=1}^{\infty} B_n^* \left(\frac{\partial u_0}{\partial y} \operatorname{sh}(2\pi n \eta) \cos(2\pi n \xi) + \frac{\partial u_0}{\partial x} \operatorname{ch}(2\pi n \eta) \sin(2\pi n \xi) \right).$$

Function $u_1^{(22)}$ is constructed in the analogous way.

Substitution of formula $u_1 = u_1^{(1)} + u_1^{(2)}$ into Equation (1.404) yields the following homogenized equation:

$$q \left(\frac{\partial^2 u_0}{\partial x^2} + \frac{\partial^2 u_0}{\partial y^2} \right) = f, \quad (1.420)$$

where

$$q = 1 - \pi a^2 + \frac{8\pi^2 a^4}{1 - \pi a^2} \times \sum_{n=1}^{\infty} \frac{n}{\operatorname{sh} \pi n} (e^{-\pi n} \operatorname{Im} E_1(\pi n(i-1)) - e^{\pi n} \operatorname{Im} E_1(\pi n(i+1))). \quad (1.421)$$

Series appeared in (1.421) is absolutely convergent with fastly decreasing terms $|a_{n+1}/a_n| \rightarrow \exp(-\pi)$.

Homogenized BC for Equation (1.420) takes the form of (1.405).

In what follows we briefly discuss a paradox reported by Bakhvalov and Eglit [31]. They considered two following cases. In the first case homogenization has been carried out for a medium with holes. In the second case a certain medium with inclusions has been homogenized, and then in the homogenized relations the characteristics of inclusions have been set to zero. The corresponding limiting systems have not coincided. However, r.h.s. of the studied Poisson equations regarding inclusions have been homogenized with respect to the whole cell area, whereas in the case of the medium with holes – only on the cell area without opening. The discussed paradox can be simply omitted. The r.h.s. for openings should be homogenized regarding the cell area without holes, whereas coefficients of the l.h.s. can be obtained via the limiting transition applied to the problem on inclusions.

1.8.8 Waves in Periodically Nonhomogenous Media

The homogenization method for the problems on waves distribution in a periodically nonhomogeneous media is often defined via representation of its solution through a scalar product of a periodic function and a certain modulated function. Mathematicians call this approach the Floquet method [70], whereas among physicists it is known as the Bloch method [86], [143].

In what follows we recall how to find a solution to differential equation with periodic coefficients. Consider the following Hill equation:

$$\frac{d^2 y(x)}{dx^2} - \varphi(x)y(x) = 0,$$

where $\varphi(x)$ is the periodic function of period a .

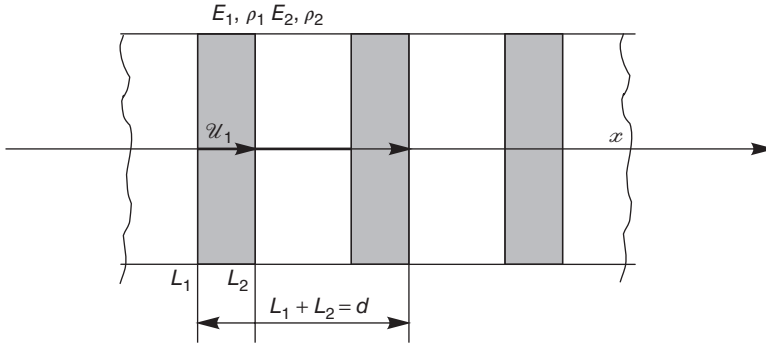

Figure 1.23 Scheme of 1D composite material

A particular solution to Hill equation, owing to the Floquet theorem [70], has the following form

$$y_1(x) = \Phi(x) \exp(i\mu x),$$

where $\Phi(x)$ is a periodic function of period a , and μ is a complex characteristic exponent.

We demonstrate a use of the homogenization method via an example of the 1D layered composite (Figure 1.23) [80]. An equation governing motion of the neighborhood composite parts follows:

$$E_k u_{kxx} - \rho_k u_{ktt} = 0, \quad k = 1, 2. \quad (1.422)$$

On the contact boundaries the following conditions hold:

$$u_1 = u_2, \quad E_1 u_{1x} = E_2 u_{2x}. \quad (1.423)$$

In addition, the following quasi-periodicity conditions should be satisfied

$$u_k(x + d, t) = u_k(x, t) \exp(ir d), \quad (1.424)$$

where $k = 1, 2$, r - wave number, $r = 2\pi/L$, L wave length.

The solution of the composite parts has the following form

$$u_k(x, t) = A_k \exp[i(p_k x + \omega t)] + B_k \exp[i(-p_k x + \omega t)], \quad (1.425)$$

where $p_k = \omega/C_k$, $C_k = \sqrt{E_k/\rho_k}$, $k = 1, 2$.

Substituting Ansatz (1.425) into BCs (1.423), (1.424), one gets a system of four linear homogenous algebraic equations regarding unknown coefficients A_k , B_k . Comparing to zero the system determinant yields the following Equation [37], [206]

$$\cos(rd) = \cos \Omega \cos(\Omega a) - \frac{b^2 + 1}{2b} \sin \Omega \sin(\Omega a), \quad (1.426)$$

where $\Omega = \frac{\omega L_1}{C_1}$, $a = \frac{L_2 C_1}{L_1 C_2}$, $b = \frac{\sqrt{E_1 \rho_1}}{\sqrt{E_2 \rho_2}}$.

In Equation (1.426) parameter b presents a rotation of impedances of composite components, whereas the parameter a stands for a time ratio associated with a wave transition.

Homogenized solution can be obtained from Equation (1.426) for small Ω and small wave number rd (long-wave approximation), and it is assumed that parameters a and b are of order 1. Developing the right- and left-hand sides of Equation (1.426) into a Maclaurin series, and retaining only the first terms, we get

$$\Omega = rd \left[(1+a)^2 + \frac{(b-1)^2 a}{b} \right]^{-1/2}. \quad (1.427)$$

In order to solve the transcendental Equations (1.426) one may apply perturbation method different from the homogenization method. Let, for instance $b = 1 + \varepsilon$, $\varepsilon \ll 1$, then Equation (1.426) can be cast into the form

$$\cos(rd) = \cos[\Omega(1+a)] - \varepsilon_1 \sin \Omega \sin(\Omega a), \quad (1.428)$$

where $\varepsilon_1 = 0, 5\varepsilon^2/(1+\varepsilon)$.

In zero order approximation we have

$$\cos(rd) = \cos[\Omega(1+a)],$$

and hence

$$\Omega_0 = (rd + 2\pi k)/(1+a).$$

Representing further the solution of Equation (1.428) in the form

$$\Omega = \Omega_0 + \varepsilon_1 \Omega_1 + \dots,$$

we get

$$\Omega_1 = -\frac{\sin \Omega_0 \sin(\Omega_0 a)}{(1+a) \sin(rd)}.$$

In the case when neighborhood composite parts differ strongly with respect to stiffness, i.e. $b \ll 1$, one may introduce a small parameter $\varepsilon_2 = 1/b$, and hence Equation (1.426) can be presented in the following form:

$$\varepsilon_2 \cos rd = \varepsilon_2 \cos \Omega \cos(\Omega a) - \frac{1}{2}(1 + \varepsilon_2^2) \sin \Omega \sin(\Omega a). \quad (1.429)$$

Possible simplification of Equation (1.429) may depend on an order of quantity a . If $a \sim 1$, then $L_1/L_2 \sim \varepsilon_2$ (length of one composite part is essentially less than the length of the second one), then a solution to Equation (1.429) can be predicted in the following form:

$$\Omega = \sqrt{\varepsilon_2} \Omega_0 + \varepsilon_2 \Omega_1 + \dots \quad (1.430)$$

Substituting series (1.430) into Equation (1.429) one gets (first approximation)

$$\cos rd = 1 - \frac{1}{2\varepsilon_2} \sin(\sqrt{\varepsilon_2} \Omega_0) \sin(\sqrt{\varepsilon_2} \Omega_0 \tau). \quad (1.431)$$

Developing the r.h.s. of formula (1.431) into series regarding Ω_0 and keeping terms of second and fourth orders, one may approximate with relatively high accuracy a chain of two periodically repeated masses coupled via the same springs [192].

References

- [1] Abassy T.A., El-Tawil M.A., Saleh H.K.: The solution of Burgers' and good Boussinesq equations using ADM-Padé technique. *Chaos, Solitons and Fractals*, 32, 1008–26 (2007).
- [2] Abramowitz M., Stegun I.A.: *Handbook of Mathematical Functions, with Formulas, Graphs, and Mathematical Tables*. Dover Publications, New York, 1965.
- [3] Andersen C.M., Dadfar M.B., Geer J.F.: Perturbation analysis of the limit cycle of the Van der Pol equation. *SIAM J. Appl. Math.*, 44(5), 881–95 (1984).
- [4] Andersen C.M., Geer J.F.: Power series expansion for the frequency and period of the limit cycle of the Van der Pol equation. *SIAM J. Appl. Math.*, 42(3), 678–93 (1982).
- [5] Andrianov I.V.: Application of Padé approximants in perturbation methods. *Adv. Mech.*, 14(2), 3–25 (1991).
- [6] Andrianov I.V., Awrejcewicz J.: New trends in asymptotic approaches: summation and interpolation methods. *Appl. Mech. Rev.*, 54(1), 69–92 (2001).
- [7] Andrianov I.V., Awrejcewicz J., Barantsev R.G.: Asymptotic approaches in mechanics: new parameters and procedures. *Appl. Mech. Rev.*, 56(1), 87–110 (2003).
- [8] Andrianov I.V., Awrejcewicz J., Weichert D.: Improved continuous models for discrete media. *Mathematical Problems in Engineering*, ID 986242 (2010).
- [9] Andrianov I.V., Bulanova N.S.: Using Padé approximants to estimate the domain of applicability of the small-parameter method. *J. Sov. Math.*, 63(5), 532–34 (1993).
- [10] Andrianov I.V., Danishevskiy V.: Asymptotic investigation of the nonlinear dynamic boundary value problem for rod. *Technische Mechanik*, 15(1), 5–35 (1995).
- [11] Andrianov I.V., Danishevskiy V.: Asymptotic approach for nonlinear periodical vibrations of continuous structures. *J. Sound Vibr.*, 249(3), 465–81 (2002).
- [12] Andrianov I.V., Gristchak V.Z., Ivankov A.O.: New asymptotic method for the natural, free and forced oscillations of rectangular plates with mixed boundary conditions. *Technische Mechanik*, 14(3/4), 185–93 (1994).
- [13] Andrianov I.V., Ivankov A.O.: Application of the Padé approximant in the method of introducing a parameter when investigating biharmonic equations with complex boundary conditions. *USSR Comp. Math. Math. Phys.*, 27(1), 193–7 (1987).
- [14] Andrianov I.V., Ivankov A.O.: New asymptotic method for solving of mixed boundary value problem. *International Series of Numerical Mathematics*, 106, 39–45 (1992).
- [15] Andrianov I.V., Ivankov A.O.: On the solution of plate bending mixed problems using modified technique of boundary conditions perturbation. *ZAMM*, 73(2), 120–2 (1993).
- [16] Andrianov I.V., Krizhevskiy G.A.: Modifications of the asymptotic method in problems of dynamics of the reinforced constructions. *Stroitel'naya Mekhanika*, 2, 66–8 (1987) (in Russian).
- [17] Andrianov I.V., Krizhevskiy G.A.: Computation of vibration modes of parallelogram plate via an approximating method. *Izvestia VUZ, Stroitel'stvo i Arhitektura*, 2, 48–9 (1988) (in Russian).
- [18] Andrianov I.V., Krizhevskiy G.A.: Analytical investigation of geometrically non-linear vibrations of sectorial plates reinforced by radial ribs. *DAN USSR A*, 11, 30–3 (1989) (in Russian).
- [19] Andrianov I.V., Lesnichaya V.A., Manevitch L.I.: *Homogenization Methods in Statics and Dynamics of Ribbed Shells*. Nauka, Moscow, 1985 (in Russian).
- [20] Andrianov I.V., Manevitch L.I.: *Asymptotology: Ideas, Methods and Applications*. Kluwer Academic Publishers, Dordrecht, Boston, London, 2002.
- [21] Andrianov I.V., Mikolenko V.A., Kholod E.G.: Nonlinear dynamics of a plane fibrous composite taking into account the width of the fiber. *Mech. Solids*, 34(2), 71–5 (1999).
- [22] Apresyan L.A.: Padé approximants. *Radiophysics and Quantum Electronics*, 22(6), 449–66 (1979).
- [23] Argatov I.I.: *Introduction to the Asymptotic Modeling in Mechanics*. Politehnika, Sankt-Petersburg, 2004 (in Russian).
- [24] Askes H., Metrikine A.V.: One-dimensional dynamically consistent gradient elasticity models derived from a discrete microstructure. Part 2: Static and dynamic response. *European J. Mechanics A/Solids*, 21, 573–88 (2002).
- [25] Awrejcewicz J., Andrianov I.V., Manevitch L.I.: *Asymptotic Approaches in the Nonlinear Dynamics: New Trends and Applications*. Springer-Verlag, Berlin, Heidelberg, 1998.

- [26] Azrar L., Benamar R., Potier-Ferry M.: An asymptotic-numerical method for large-amplitude free vibrations of thin elastic plates. *J. Sound Vibr.*, 220(4), 695–727 (1999).
- [27] Azrar L., Cochelin B., Damil N., Potier-Ferry M.: An asymptotic numerical method to compute the post-buckling behaviour of elastic plates and shells. *Int. J. Num. Meth. Eng.*, 36, 1187–1213 (1994).
- [28] Babich V.M., Buldyryev V.S.: *Asymptotic Methods in Short Wave Diffraction Problems*. Nauka, Moscow, 1972 (in Russian).
- [29] Baker G.A.: *Essential of Padé Approximation*. Academic Press, New York, 1975.
- [30] Baker G.A., Graves-Morris P.: *Padé Approximants*. Cambridge University Press, Cambridge, New York, 1996.
- [31] Bakhvalov N.S., Eglit M.E.: On limiting behavior of periodic media with soft-moduli inclusions. *Comp. Math. Math. Physics*, 35(6), 719–29 (1995).
- [32] Bakhvalov N.S., Panasenko G.P.: *Averaging Processes in Periodic Media: Mathematical Problems in Mechanics of Composite Materials*. Kluwer, Dordrecht, 1989.
- [33] Basdevant J.L.: The Padé approximation and its physical applications. *Fort. Phys.*, 20(5), 284–328 (1977).
- [34] Bauer S.M., Filippov S.B., Smirnov A.L., Tovstik P.E.: Asymptotic methods in mechanics with applications to thin shells and plates. *Asymptotic Methods in Mechanics. CRM Proc. Lect. Notes*, 3, 3–140 (1994).
- [35] Beckermann B., Kaliaguine V.: The diagonal of the Padé table and the approximation of the Weyl function of the second-order difference operator. *Constr. Appr.*, 13, 481–510 (1997).
- [36] Beckermann B., Matos A.S., Wielonsky F.: Reduction of the Gibbs phenomenon for smooth functions with jumps by the ε -algorithm. *J. Comp. Appl. Math.*, 219, 329–49 (2008).
- [37] Bedford A., Drumheller D.S.: *Introduction to Elastic Wave Propagation*. John Wiley & Sons, Ltd., Chichester, 1996.
- [38] Bellman R.: Perturbation methods applied to nonlinear dynamics. *J. Appl. Math.*, 22, 500–2 (1955).
- [39] Bellman R.: *Perturbation Techniques in Mathematics, Physics and Engineering*. Holt, Rinehart and Winston, New York, 1964.
- [40] Bender C.M., Boetcher S.: Continued fraction as a discrete nonlinear transform. *J. Math. Phys.*, 35(1), 364–7 (1994).
- [41] Bender C.M., Boetcher S.: Determination of $f(\infty)$ from the asymptotic series for $f(x)$ about $x = 0$. *J. Math. Phys.*, 35(4), 1914–21 (1994).
- [42] Bender C.M., Boetcher S., Milton K.A.: A new perturbative approach to nonlinear partial differential equations. *J. Math. Phys.*, 32(11), 3031–8 (1991).
- [43] Bender C.M., Milton K.A., Pinsky S.S., Simmons L.M. Jr.: A new perturbation approach to nonlinear problems. *J. Math. Phys.*, 30(7), 1447–55 (1989).
- [44] Bender C.M., Orszag S.A.: *Advanced Mathematical Methods for Scientists and Engineers*. McGraw-Hill, New York, 1978.
- [45] Bender C.M., Vinson J.P.: Summations of power series by continued exponentials. *J. Math. Phys.*, 37(8), 4103–19 (1996).
- [46] Bensoussan A., Lions J.-L., Papanicolaou G.: *Asymptotic Analysis for Periodic Structures*. North-Holland, Amsterdam, 1978.
- [47] Berdichevskii V.L.: *Variational Principles of Mechanics of Continuous Media*. Nauka, Moscow, 1983 (in Russian).
- [48] Berger H.M.: A new approach to analysis of large deflections of plates. *J. Appl. Mech.*, 22(4), 465–72 (1955).
- [49] Bernoulli J.: De chordis vibrantibus. *Commentarii Academiae Scientiarum Imperialis Petropolitanae*, 3, 13–28 (1728).
- [50] Berry M.V.: Asymptotics, superasymptotics, hyperasymptotics. *NATO ASI Series*, 284, 1–14 (1992).
- [51] Berrut J.-P., Mittelmann H.D.: Lebesgue constant minimizing linear rational interpolation of continuous functions over the interval. *Computers and Mathematics with Applications*, 33, 77–86 (1997).
- [52] Berry M.V., Howls C.J.: Hyperasymptotics. *Proc. Roy. Soc. A*, 430, 653–68 (1990).
- [53] Berry M.V., Howls C.J.: Hyperasymptotics for integrals with saddles. *Proc. Roy. Soc. A*, 434, 657–75 (1991).
- [54] Bessis D.: Padé approximants in noise filtering. *J. Comp. Appl. Math.*, 66, 85–8 (1996).
- [55] Blanc X., Bris C.Le., Lions P.-L.: From molecular models to continuum mechanics. *Archive Rational Mech. Anal.*, 164, 341–81 (2002).
- [56] Boettcher S., Bender C.M.: Nonperturbative square-well approximation to a quantum theory. *J. Math. Phys.*, 31(11), 2579–85 (1990).

- [57] Bogoliubov N.N. Mitropolsky Yu.A.: *Asymptotic Methods in the Theory of Nonlinear Oscillations*. Gordon and Breach, London, 1985.
- [58] Bolotin V.V.: The edge effect in the oscillations of elastic shells. *J. Appl. Math. Mech.*, 24(5), 1257–72 (1960).
- [59] Bolotin V.V.: *Random Vibrations of Elastic Systems*. Martinus Nijhoff Publ., the Hague, Boston, 1984.
- [60] Bolotin V.V., Novichkov Y.N.: *Mechanics of Multi-Layer Structures*. Mashinostroyeniye, Moscow, 1980 (in Russian).
- [61] Born M., Huang K.: *Dynamical Theory of Crystal Lattices*. Oxford University Press, Oxford, 1954.
- [62] Bosley D.L.: A technique for the numerical verification of asymptotic expansions. *SIAM Rev.*, 38(1), 128–35 (1996).
- [63] Bourgat J.F.: Numerical experiments of the homogenization method for operators with periodic coefficients. *Lecture Notes Math.*, 704, 330–56 (1979).
- [64] Boyd J.P.: *Weakly Nonlocal Solitary Waves and Beyond-All-Orders Asymptotics. Generalized Solutions and Hyperasymptotic Perturbation Theory*. Kluwer, Dordrecht, 1998.
- [65] Boyd J.P.: The Devil's invention: asymptotic, superasymptotic and hyperasymptotic series. *Acta Applicandae Mathematicae*, 56, 1–98 (1999).
- [66] Braides A., Gelli M.S.: The passage from discrete to continuous variational problems: a nonlinear homogenization process. *Nonlinear Homogenization and its Appl. to Composites, Polycrystals and Smart Materials*. Eds. Ponte Castaneda P., Telega J.J., Gambin B. Dordrecht: Kluwer, 2004, 45–64.
- [67] Brezinski C.: Composite sequence transformations. *Numerical Mathematics*, 46, 311–21 (1985).
- [68] Brezinski C.: Convergence acceleration during the 20th century. *J. Comp. Appl. Math.*, 122, 1–21 (2000).
- [69] Brezinski C.: Extrapolation algorithms for filtering series of functions, and treating the Gibbs phenomenon. *Numerical Algorithms*, 36, 309–29 (2004).
- [70] Brillouin L., Parodi M.: *Waves Propagation in Periodic Structures*. Dover, New York, 1953.
- [71] Bruno A.D.: *Power Geometry in Algebraic and Differential Equations*. Elsevier, Amsterdam, 2000.
- [72] Bruno A.D.: Self-similar solutions and power geometry. *Russ. Math. Surv.*, 55(1), 1–42 (2000).
- [73] Buonomo A.: The perturbation solution of Van der Pol's equation. *SIAM J. Appl. Math.*, 59(1), 156–71 (1998).
- [74] Cabay S., Domzy B.: Systems of linear equations with dense univariate polynomial coefficients. *J. Assoc. Comp. Mech.*, 34(3), 46–60 (1987).
- [75] Chalbaud E., Martin P.: Two-point quasifractional approximant in physics: method improvement and application to $J_n(x)$. *J. Math. Phys.*, 33, 2483–248 (1992).
- [76] Chen G., Coleman M. P., Zhou J.: Analysis of vibration eigenfrequencies of a thin plate by the Keller-Rubinow wave method I: Clamped boundary conditions with rectangular or circular geometry. *SIAM J. Appl. Math.*, 51(4), 967–83 (1991).
- [77] Chen G., Coleman M. P., Zhou J.: The equivalence between the wave propagation method and Bolotin's method in the asymptotic estimation of eigenfrequencies of a rectangular plate. *Wave Motion*, 16(3), 285–97 (1992).
- [78] Chen G., Zhou J.: *Vibration and Damping in Distributed Systems*, vol. I, II. CRS, Boca Raton, FL, 1993.
- [79] Chen S.H., Cheung Y.K.: An elliptic perturbation method for certain strongly non-linear oscillators. *J. Sound Vibr.*, 192(2), 453–64 (1996).
- [80] Chen W., Fish J.: A dispersive model for wave propagation in periodic heterogeneous media based on homogenization with multiple spatial and temporal scales. *J. Appl. Mech.*, 86, 153–61 (2001).
- [81] Cherkaev E., Ou M.-J.Y.: Dehomogenization: reconstruction of moments of the spectral measure of the composite. *Inverse Problems*, 24, 065008 (2008).
- [82] Cochelin B.: A path-following technique via an asymptotic-numerical method. *Comp. Struct.*, 53(5), 1181–92 (1994).
- [83] Cochelin B., Damil N., Potier-Ferry M.: Asymptotic-numerical methods and Padé approximants for non-linear elastic structures. *Int. J. Num. Meth. Eng.*, 37(7), 1187–1213 (1994).
- [84] Collins M.A.: A quasi-continuum approximation for solitons in an atomic chain. *Chemical Phys. Lett.*, 77(2), 342–7 (1981).
- [85] Common A.K.: Application of Hermite-Padé approximants to water waves and the harmonic oscillator on a lattice. *J. Phys. A*, 15, 3665–77 (1982).
- [86] Conca C., Lund F.: Fourier homogenization method and the propagation of acoustic waves through a periodic vortex array. *SIAM J. Appl. Math.*, 59(5), 573–81 (1999).

- [87] Corless R.M., Gonnet G.H., Hare D.E.G., Jeffrey D.J., Knuth D.E.: On the Lambert W function. *Advances in Computational Mathematics*, 5, 329–59 (1996).
- [88] Crighton D.G.: Asymptotics—an indispensable complement to thought, computation and experiment in applied mathematical modelling. *Seventh European Conf. on Mathematics in Industry*. Eds. Fasano A., Primicerio M.B. Stuttgart: G.Teubner, 3–19 (1994).
- [89] Dadfar M.B., Geer J.F.: Power series solution to a simple pendulum with oscillating support. *SIAM J. Appl. Math.*, 47(4), 737–50 (1987).
- [90] Damil N., Potier-Ferry M.: A new method to compute perturbed bifurcation: application to the buckling of imperfect elastic structures. *Int. J. Eng. Sc.*, 28, 943–57 (1990).
- [91] Del Piero G., Truskinovsky L.: Macro and micro cracking in one-dimensional elasticity. *Int. J. Solids Struct.*, 38, 1135–48 (2001).
- [92] Dingle R.B.: *Asymptotic Expansions: Their Derivation and Interpretation*. Academic Press, New York, London, 1973.
- [93] Dowell E.H., Tang D.: Multiscale, multiphenomena modelling and simulation at the nanoscale: on constructing reduced-order models for nonlinear dynamical systems with many degrees-of-freedom. *J. Appl. Mech.*, 70, 328–38 (2003).
- [94] Drazin P.G., Tourigny Y.: Numerical study of bifurcations by analytic continuation of a function defined by a power series. *SIAM J. Appl. Math.*, 56, 1–18 (1996).
- [95] Driscoll T.A., Fornberg B.: A Padé-based algorithm for overcoming the Gibbs phenomenon. *Numerical Algorithms*, 26, 77–92 (2001).
- [96] Eckhaus W.: *Matched Asymptotic Expansions and Singular Perturbations*. North-Holland, Amsterdam, 1973.
- [97] Eckhaus W.: *Asymptotic Analysis of Singular Perturbations*. North-Holland, Amsterdam, 1979.
- [98] Elhage-Hussein A., Potier-Ferry M., Damil N.: A numerical continuation method based on Padé approximants. *Int. J. Solids Struct.*, 37, 6981–7001 (2000).
- [99] Emachi E., Vakakis A.F., Andrianov I.V., Mikhlin Yu.V.: Study of two-dimensional axisymmetric breathers using Padé approximants. *Non. Dyn.*, 13, 327–38 (1997).
- [100] Estrada R., Kanwal R.P.: *A Distributional Approach to Asymptotics: Theory and Applications*. Birkhäuser, Boston, 2002.
- [101] Fedoriyuk M.V.: *Asymptotics: Integrals and Series*. Nauka, Moscow, 1987 (in Russian).
- [102] Fidl A.: A new technique of selection between sequence transformations. *Applied Numerical Mathematics*, 25, 21–40 (1997).
- [103] Filatov A.N.: *Asymptotic Method in Theory of Differential and Integro-Differential Equations*. FAN, Tashkent, 1974 (in Russian).
- [104] Filatov A.N., Sharova L.V.: *Integral Inequalities and Theory of Non-Linear Vibrations*. Nauka, Moscow, 1976 (in Russian).
- [105] Filimonov A.M.: Some unexpected results in the classical problem of vibrations of the string with N beads. The case of multiple frequencies. *C. R. Acad. Sci.*, 315(8), 957–61 (1991).
- [106] Filimonov A.M.: Continuous approximations of difference operators. *J. Difference Eq. Appl.*, 2(4), 411–22 (1998).
- [107] Filimonov A.M., Kurchanov P.F., Myshkis A.D.: Some unexpected results in the classical problem of vibrations of the string with n beads when n is large. *C. R. Acad. Sci.*, 313, 961–5 (1991).
- [108] Floater M.S., Hormann K.: Barycentric rational interpolation with no poles and high rates of approximation. *Numerische Mathematik*, 107, 315–31 (2007).
- [109] Friedrichs K.O.: Asymptotic phenomena in mathematical physics. *Bull. Amer. Math. Soc.*, 61, 485–504 (1955).
- [110] Friedrichs K.O.: *Perturbation of Spectra in Hilbert Space*. AMS, Providence, RI, 1965.
- [111] Friesecke G., Theil F.: Validity and failure of the Cauchy-Born hypothesis in a two-dimensional mass-spring lattice. *J. Nonlin. Sciences*, 12, 445–78 (2002).
- [112] Frost P.A., Harper E.Y.: Extended Padé procedure for constructing global approximations from asymptotic expansions: an explication with examples. *SIAM Rev.*, 18(1), 62–91 (1976).
- [113] Gaunt D.S., Guttman A.J.: Series expansions: analysis of coefficients. *Phase Trans. Crit. Phen.*, 3, 181–243, (1974).
- [114] Gekeler E.: On the solution of system of equations by the epsilon algorithm of Wynn. *Math. Comp.*, 26, 427–36 (1972).
- [115] Giacaglia G.E.O.: *Perturbation Methods in Non-Linear Systems*. Springer, New York, 1972.

- [116] Gilewicz J., Pindor M.: Padé approximants and noise: A case of geometrical series. *J. Comp. Appl. Math.*, 87, 199–214 (1997).
- [117] Gilewicz J., Pindor M.: Padé-type approximants and error of Padé approximants. *J. Comp. Appl. Math.*, 99, 155–65 (1998).
- [118] Gilewicz J., Pindor M.: Padé approximants and noise: rational functions. *J. Comp. Appl. Math.*, 105, 285–97 (1999).
- [119] Gol'denveizer A.L.: *Theory of Elastic Thin Shells*. Pergamon Press, New York, 1961.
- [120] Gonchar A.A.: Some recent convergence results on diagonal Padé approximants. In: *Approximation Theory V*. Academic Press, Boston, 55–70 (1986).
- [121] Gontkevich V.S.: *Free Vibrations of Plates and Shells*. Naukova Dumka, Kiev, 1964 (in Russian).
- [122] Grigolyuk E.I., Filshinskiy L.A.: *Perforat Plates and Shells*. Nauka, Moscow, 1970 (in Russian).
- [123] Grigolyuk E.I., Filshinskiy L.A.: *Periodic Piece-Wise Homogeneous Elastic Structures*. Nauka, Moscow, 1992 (in Russian).
- [124] Grigolyuk E.I., Kulikov G.M.: *On a Simplified Method of Solution to Non-Linear Problems of Elastic Plates and Shells: Some Problems of Theory of Plates and Shells*. MGU Press, Moscow, 1981 (in Russian).
- [125] Grundy R.E.: Laplace transform inversion using two-point rational approximants. *J. Inst. Math. Appl.*, 20, 299–306 (1977).
- [126] Grundy R.E.: On the solution of nonlinear Volterra integral equations using two-point Padé approximants. *J. Inst. Math. Appl.*, 22, 317–20 (1978).
- [127] Grundy R.E.: The solution of Volterra integral equation of the convolution type using two-point rational approximants. *J. Inst. Math. Appl.*, 22, 147–58 (1978).
- [128] Handy C.R.: Harmonic balance method and the theory of generalized Padé approximants. *J. Sound Vibr.*, 102(2), 247–57 (1985).
- [129] He Ji-Huan: A new approach to nonlinear partial differential equations. *Com. Non. Sc. Num. Sim.*, 2(4), 230–5 (1997).
- [130] He Ji-Huan: Homotopy perturbation technique. *Comp. Meth. Appl. Mech. Eng.*, 178, 257–256 (1999).
- [131] He Ji-Huan: A coupling method of homotopy technique and a perturbation technique for non-linear problems. *Int. J. Nonlin. Mech.*, 35, 37–43 (2000).
- [132] He Ji-Huan: Recent developments of the homotopy perturbation method. *Top. Meth. Nonlin. Anal.*, 31, 205–9 (2008).
- [133] Hinch E.J.: *Perturbation Methods*. University Press, Cambridge, 1991.
- [134] Holmes M.H.: *Introduction to Perturbation Methods*. Springer, New York, 1995.
- [135] Jamai R., Damil N.: Quadratic approximants in the asymptotic numerical method. *C.R. Acad. Sci. Paris*, series II b, 329, 809–14 (2001).
- [136] Jones W.B., Thron W.J.: *Continued Fractions. Analytic Theory and Its Applications*. Addison-Wesley, New York, 1980.
- [137] Kaas-Petersen C.: Continuation methods as the link between perturbation analysis and asymptotic analysis. *SIAM Rev.*, 29(1), 115–20 (1987).
- [138] Kalamkarov A.L.: *Composite and Reinforced Elements of Construction*. John Wiley & Sons, Ltd, Chichester, 1992.
- [139] Kalamkarov A.L., Kolpakov A.G.: *Analysis, Design and Optimization of Composite Structures*. John Wiley & Sons, Ltd, Chichester, 1997.
- [140] Kalamkarov A.L., Kudriavtsev B.A., Parton V.Z.: Asymptotic method of averaging in mechanics of composites of regular structure. *Achievements in Science and Techniques. VINITI, Series Mechanics of Solids*, 19, 78–147 (1987) (in Russian).
- [141] Kauderer H.: *Nichtlineare Mechanik*. Springer, Berlin, 1958.
- [142] Kantorovich L.V., Krylov V.I.: *Approximate Methods of Higher Analysis*. Noordhoff, Groningen, 1958.
- [143] Karpov S.Yu., Stolyarov S.N.: Propagational transformation of electromagnetic waves in one-dimensional periodic structures. *Phys. Usp.*, 36(1), 1–22 (1993).
- [144] Kashin A.P., Kvaratskheliya T.M., Maksimov M.Z., Chikovani Z.E.: Higher approximations of the reduced method of matched asymptotic expansions and its convergence. *Theor. Math. Phys.*, 78, 278–84 (1989).
- [145] Kayuk Ya.F.: *Some Problems of the Methods Splitting by Parameters*. Naukova Dumka, Kiev, 1991 (in Russian).
- [146] Keller J.B., Rubinow S.I.: Asymptotic solution of eigenvalue problems. *Ann. Phys.*, 9(1), 24–75 (1960).
- [147] Kevorkian J., Cole J.D.: *Multiple Scale and Singular Perturbation Methods*. Springer, New York, 1996.

- [148] Kolpakov A.G.: *Stressed Composite Structures: Homogenized Models for Thin-Walled Nonhomogeneous Structures with Initial Stresses*. Springer-Verlag, Berlin, New York, 2004.
- [149] Kosevich A.M., Kovalov A.S.: *Introduction to Non-Linear Physical Mechanics*. Naukova Dumka, Kiev, 1989 (in Russian).
- [150] Krivtsov A.M.: *Deformation and Damage of Rigid Bodies with Microstructure*. Fizmat, Moscow, 2007 (in Russian).
- [151] Kruskal M.D.: Asymptotology. *Mathematical Models in Physical Sciences. Proceedings of the conference held at Notre Dame, Indiana, April 1962*. Prentice-Hall, Englewood Cliffs, N.J., 17–48, 1963.
- [152] Kunin I.A.: *Elastic Media with Microstructure*. vol. 1,2, Springer, Berlin, 1982, 1983.
- [153] Kuzmak G.E.: Asymptotic solution of nonlinear second order differential equations with variable coefficients. *J. Appl. Math. Mech.*, 23, 730–44 (1959).
- [154] Kurchanov P.F., Myshkis A.D., Filimonov A.M.: Vibrations of rolling stock and a theorem of Kronecker. *J. Appl. Math. Mech.*, 55(6), 870–6 (1991).
- [155] Lambert F., Musette M.: Solitary waves, padeons and solitons. *Lect. Not. Math.*, 1071, 197–212 (1984).
- [156] Lambert F., Musette M.: Solitons from a direct point of view: padeons. *J. Comp. Appl. Math.*, 15, 235–49 (1986).
- [157] Li Jian-Lin: Adomian's decomposition method and homotopy perturbation method in solving nonlinear equations. *J. Comp. Appl. Math.*, 228(1), 168–73 (2009).
- [158] Liao S.J.: *Beyond Perturbation: Introduction to the Homotopy Analysis Method*. Chapman and Hall/CRC Press, Boca Raton, 2004.
- [159] Liapunov A.M.: An investigation of one of the singular cases of the theory of stability of motion, II. *Mathematicheskii Sbornik*, 17(2), 253–333 (1893). (Eng. Transl. in 1603, 128–84).
- [160] Liapunov A.M.: *Stability of Motion*. Academic Press, New York, 1966.
- [161] Lighthill M.J.: A technique for rendering approximate solutions to physical problems uniformly valid. *Phil. Mag.*, 40, 1179–1201 (1949).
- [162] Lin S.S., Segel L.A.: *Mathematics Methods Applied to Deterministic Problems in the Natural Sciences*. SIAM, Philadelphia, 1988.
- [163] Litvinov G.L.: Approximate construction of rational approximations and the effect of autocorrection error. *Russian J. Math. Phys.*, 1(3), 313–52 (1994).
- [164] Litvinov G.L.: Error autocorrection in rational approximation and interval estimation. *Central European J. Math.*, 1(1), 1–33 (2003).
- [165] Luke Y.L.: Computations of coefficients in the polynomials of Padé approximation by solving system of linear equations. *J. Comp. Appl. Math.*, 6(3), 213–18 (1980).
- [166] Luke Y.L.: A note on evaluation of coefficients in the polynomials of Padé approximation by solving system of linear equations. *J. Comp. Appl. Math.*, 8(2), 93–9 (1982).
- [167] Mandelshtam L.I.: *Lectures on the Theory of Oscillations*. Nauka, Moscow, 1972 (in Russian).
- [168] Manevitch L.I.: Nonlinear normal modes and solitons. In: Scott E. *Nonlinear Science: the Birth and Development of Coherent Structures*. Fizmatlit, Moscow, 2007, 532–45 (in Russian).
- [169] Manevitch L.I., Andrianov I.V., Oshmyan V.O.: *Mechanics of Periodically Heterogeneous Structures*. Springer-Verlag, Berlin, 2002.
- [170] Manevitch A.I., Manevitch L.I.: *The Mechanics of Nonlinear Systems with Internal Resonances*. World Scientific, New York, 2005.
- [171] Manevitch L.I., Mikhlin Yu.V., Philipchuk V.N.: *Method of Normal Vibrations for Essentially Non-Linear Systems*. Nauka, Moscow, 1989 (in Russian).
- [172] March R., Barone P.: Application of the Padé method to solving the noisy trigonometric moment problem: some initial results. *SIAM J. Appl. Math.*, 58(1), 324–43 (1998).
- [173] Marchuk G.I., Agoshkov V.I.: Conjugate operators and algorithms of perturbation in non-linear problems: 1. Principles of construction of conjugate operators. *Soviet J. Num. Math. Modeling*, 1, 21–46 (1988).
- [174] Marchuk G.I., Agoshkov V.I.: Conjugate operators and algorithms of perturbation in non-linear problems: 2. Perturbation algorithms. *Soviet J. Num. Math. Modeling*, 2, 115–36 (1988).
- [175] Marchuk G.I., Agoshkov V.I., Shutyaev V.P.: *Adjoint Equations and Perturbation Algorithms in Nonlinear Problems*. CRC Press, Boca Raton, RI, 1996.
- [176] Martin P., Baker G.A. Jr.: Two-point quasifractional approximant in physics. Truncation error. *J. Math. Phys.*, 32(6), 313–28 (1991).
- [177] Mason J.C.: Some applications and drawbacks of Padé approximants. *Appr. Theory Appl.*, 207–23 (1981).
- [178] Maslov V.P.: *Operational Methods*. Mir, Moscow, 1976 (in Russian).

- [179] Maslov V.P.: *The Complex WKB Method for Nonlinear Equations I: Linear Theory*. Birkhäuser, Basel, Boston, 1994.
- [180] Maslov V.P.: *Asymptotic Methods and Theory of Perturbations*. Nauka, Moscow, 1988 (in Russian).
- [181] Maslov V.P., Omel'yanov G.A.: *Geometric Asymptotic for Nonlinear PDE*. I. Providence, RI: AMS, 2001.
- [182] McKenzie D.R., McPhedran R.C.: Exact modelling of cubic lattice permittivity and conductivity. *Nature*, 265, 128–9 (1977).
- [183] McKenzie D.R., McPhedran R.C., Derrick G.H.: The conductivity of lattices of spheres II. The body-centered and face-centered lattices. *Proc. R. Soc. A*, 362, 211–32 (1978).
- [184] McPhedran R.C., McKenzie D.R.: The conductivity of lattices of spheres. I. The simple cubic lattice. *Proc. R. Soc. A*, 359, 45–63 (1978).
- [185] McPhedran R.C., Milton G.W.: Bounds and exact theories for the transport properties of inhomogeneous media. *Appl. Phys. A: Mater. Sci. Proc.*, 26, 207–20 (1981).
- [186] Meredith R.E., Tobias G.W.: Resistance to potential flow through a cubical array of spheres. *J. Appl. Phys.*, 31, 1270–3 (1960).
- [187] Mickens R.E.: A generalization of the method of harmonic balance. *J. Sound Vibr.*, 111, 515–18 (1986).
- [188] Miller P.D.: *Applied Asymptotic Analysis*. AMS, Rhode Island, Providence, 2006.
- [189] Moiseev N.N.: *Asymptotic Methods in Non-Linear Mechanics*. Nauka, Moscow, 1981 (in Russian).
- [190] Mokhtari R.E., Cadou J.-M., Potier-Ferry M.: A two grid algorithm based on perturbation and homotopy method. *Mechanique*, 330, 825–30 (2002).
- [191] Molotkov I.A., Vakulenko S.A.: *Localized Nonlinear Waves*. LGU, Leningrad, 1988 (in Russian).
- [192] Movchan A.B., Movchan N.V., Poulton C.G.: *Asymptotic Models of Fields in Dilute and Densely Packed Composites*. Imperial College Press, London, 2002.
- [193] Myshkis A.D.: Mixed functional differential equations. *J. Math. Sc.*, 129(5), 4111–26 (2005).
- [194] Nayfeh A.H.: *Introduction to Perturbation Techniques*. John Wiley and Sons, Inc., New York, 1981.
- [195] Nayfeh A.H.: *Perturbation Methods*. John Wiley and Sons, Inc., New York, 2000.
- [196] Nemeth G., Paris G.: The Gibbs phenomenon in generalized Padé approximation. *J. Math. Phys.*, 26(6), 1175–8 (1985).
- [197] Olver F.W.J.: *Asymptotic and Special Functions*. AK Peters, Wellesley, 1997.
- [198] O'Malley R.E.: *Singular Perturbation Methods for Ordinary Differential Equations*. Springer-Verlag, New York, 1991.
- [199] Pagano S., Paroni R.: A simple model for phase transition: from the discrete to the continuum problem. *Quart. Appl. Math.*, 61, 89–109 (2003).
- [200] Panovko Ya.G.: *Mechanics of Deformable Rigid Body: Modern Concepts, Errors and Paradoxes*. Nauka, Moscow, 1985 (in Russian).
- [201] Paroni R.: From discrete to continuum: a Young measure approach. *ZAMP*, 54(2), 328–48 (2003).
- [202] Peierls R.E.: *Surprises in Theoretical Physics*. Princeton University Press, Princeton, 1979.
- [203] Pichugin A.V., Askes H., Tyas A.: Asymptotic equivalence of homogenization procedures and fine-tuning of continuum theories. *J. Sound Vibr.*, 313, 858–74 (2008).
- [204] Pilipchuk V.N.: *Nonlinear Dynamics: Between Linear and Impact Limits*. Springer, New York, 2010.
- [205] Pinney E.: *Ordinary Difference-Differential Equations*. Univ. California Press, Berkeley and Los Angeles, 1958.
- [206] Pobedrya B.E.: *Mechanics of Composite Material*. MGU, Moscow, 1984 (in Russian).
- [207] Poincaré H.: *New Methods in Celestial Mechanics*. Ed. and introd. D.L. Goroff. Woodbury, AIP, 1993.
- [208] Poston T., Stewart I.: *Catastrophe Theory and its Applications*. Pitman, London, 1978.
- [209] Prudnikov A.P., Brychkov O.A., Marichev O.I.: *Integrals and Series*. Gordon and Breach, New York, 1992.
- [210] Reuss A.: Berechnung der Fließgrenze an Mischkristallen auf Grund der Plastizitätsbedingungen für Einkristall. *ZAMM*, 9, 49–58 (1929).
- [211] Rosenau Ph.: Dynamics of nonlinear mass-spring chains near the continuum limit. *Physics Letters A*, 118(5), 222–7 (1986).
- [212] Rosenau Ph.: Hamiltonian dynamics of dense chains near and lattices: or how to correct the continuum. *Physics Letters A*, 311(5), 39–52 (2003).
- [213] Rosenberg R.M.: The normal modes of nonlinear n-degree-of-freedom systems. *J. Appl. Mech.*, 29, 7–14 (1962).
- [214] Rosenberg R.M.: The Ateb(h)-functions and their properties. *Quart. Appl. Math.*, 21, 37–47 (1963).
- [215] Sangani A.S., Acrivos A.: The effective conductivity of a periodic array of spheres. *Proc. R. Soc. A*, 386, 263–75 (1983).

- [216] Scorobogat'ko V. Ya.: *Theory of the Branching Continued Fractions and its Application in the Numerical Mathematics*. Nauka, Moscow, 1983 (in Russian).
- [217] Segel L.A.: The importance of asymptotic analysis in applied mathematics. *American Mathematical Monthly*, 73, 7–14 (1966).
- [218] Semerdjiev Kh.: Trigonometric Padé Approximants and Gibbs phenomenon. *Rep. United Inst. Nuclear Research NP5-12484*, Dubna, 1979 (in Russian).
- [219] Senik P.M.: Inversion of the incomplete Beta function. *Ukrainian Math. J.*, 21, 271–8 (1969).
- [220] Sergeev A.V.: A recursive algorithm for Padé-Hermite approximations. *USSR Comp. Math. Math. Phys.*, 26(2), 17–22 (1986).
- [221] Shafer R.E.: On quadratic approximation. *SIAM J. Numer. Anal.*, 11, 447–60 (1974).
- [222] Shamrovskii A.D.: Asymptotic integration of static equation of the theory of elasticity in Cartesian coordinates with automated search of integration parameters. *J. Appl. Math. Mech.*, 43(5), 925–34 (1979).
- [223] Shamrovskii A.D., Andrianov I.V., Awrejcewicz J.: Asymptotic-group analysis of algebraic equations. *Math. Probl. Eng.*, 5, 411–51 (2004).
- [224] Shanks D.: Non-linear transformation of divergent and slowly convergent sequence. *J. Math. Phys.*, 34(1), 1–42 (1955).
- [225] Shaw S.W., Pierre C.: Normal modes of vibration for non-linear continuous systems. *J. Sound Vibr.*, 169(3), 319–47 (1994).
- [226] Sawyer B., Watson B.: *Borel's Method of Summability. Theory and Applications*. Clarendon Press, Oxford, 1994.
- [227] Shokin Y.I.: *The Method of Differential Approximation*. Springer, Berlin, 1983.
- [228] Slavyanov S.Yu.: *Asymptotic Solutions of the One-dimensional Schrödinger Equation*. AMS, Providence, R.I., 1996.
- [229] Slepuyan L.I., Yakovlev Yu.S.: *Integral Transforms in Non-steady-state Problems of Mechanics*. Sudostroyeniye, Leningrad, 1980 (in Russian).
- [230] Stermin B., Shatalov V.: *Borel-Laplace Transform and Asymptotic Theory. Introduction to Resurgent Analysis*. CRC Press, N.Y., 1995.
- [231] Suetin S.P.: Padé approximants and efficient analytic continuation of a power series. *Russ. Math. Surv.*, 57(1), 43–141 (2002).
- [232] Suetin S.P.: On interpolation properties of diagonal Padé approximants of elliptic functions. *Russ. Math. Surv.*, 59, 201–2 (2004).
- [233] Timoshenko S.P., Woinowsky-Krieger S.: *Theory of Plates and Shells*. 2nd ed., McGraw-Hill, New York, 1987.
- [234] Tokarzewski S., Telega J.J.: S-continued fraction method for the investigation of a complex dielectric constant of two-phase composite. *Acta Appl. Math.*, 49, 55–83 (1997).
- [235] Tovstik P.E., Bauer S.M., Smirnov A.L., Filippov S.B.: *Asymptotic Methods in Mechanics of Thin-Walled Structures*. SP University Press, Sankt-Petersburg, 1995 (in Russian).
- [236] Ulam S.: *Collection of Mathematical Problems*. Interscience, New York, 1960.
- [237] Vainberg M.M., Trenogin V.A.: *Theory of Branching of Solutions of Non-linear Equations*. Noordhoff International Publishing, Leyden, 1974.
- [238] Vakman D.E.: *Signals, Oscillations, and Waves: A Modern Approach*. Artech House, Boston, 1998.
- [239] Vakakis A.F., Manevitch L.I., Mikhlin Yu.V., Pilipchuk V.N., Zevin A.A.: *Normal Modes and Localization in Nonlinear Systems*. Wiley Interscience, New York, 1996.
- [240] Vakhromeyev Yu.M., Kornev V.M.: Dynamical boundary effect in rods. Formulation truncated problems. *Izv. AN of USSR, Mekhanika Tverdogo Tela*, 4, 95–103 (1972) (in Russian).
- [241] Van der Pol B., Bremmer H.: *Operational Calculus Based on the Two-Sided Laplace Integral*. Chelsea Publishing Company, London, 1987.
- [242] Van Dyke M.: Analysis and improvement of perturbation series. *Quart. J. Mech. Appl. Math.*, 27, 423–50 (1974).
- [243] Van Dyke M.: Computer extension of perturbation series in fluid mechanics. *SIAM J. Appl. Math.*, 28, 720–34 (1975).
- [244] Van Dyke M.: *Perturbation Methods in Fluid Mechanics*. The Parabolic Press, Stanford, 1975.
- [245] Van Dyke M.: From zero to infinite Reynolds by computing extension of Stokes series. *Lec. Not. Math.*, 594, 506–17 (1977).
- [246] Van Dyke M.: *Mathematical Approaches in Hydrodynamics*. SIAM, Philadelphia, 1991.

- [247] Vavilov V.V., Tchobanou M.K., Tchobanou P.M.: Design of multi-dimensional recursive systems through Padé type rational approximation. *Non. Anal.: Modell. Contr.*, 7(1), 105–25 (2002).
- [248] Verhulst F.: *Methods and Applications of Singular Perturbations, Boundary Layers and Multiple Timescale Dynamics*. Springer-Verlag, Berlin, 2005.
- [249] Vinogradov V.N., Gay E.V., Rabotnov N.C.: *Analytical Approximation of Data in Nuclear and Neutron Physics*. Energoatomizdat, Moscow, 1987 (in Russian).
- [250] Vishik M.I., Lyusternik L.A.: Solution of some problems about perturbation for matrix and selfadjoint and nonselfadjoint differential equations. *Russ. Math. Surv.*, 15(3), 3–80 (1960).
- [251] Vishik M.I., Lyusternik L.A.: The asymptotic behaviour of solutions of linear differential equations with large or quickly changing coefficients and boundary conditions. *Russ. Math. Surv.*, 15(4), 23–91 (1960).
- [252] Voigt W. Über die Beziehung zwischen den beiden Elasticitätsconstanten isotroper Körper. *Annalen der Physik und Chemie*, 38, 573–87 (1889).
- [253] Volmir A.S.: *Stability of Elastic Systems*. Fizmatgiz, Moscow, 1963 (in Russian).
- [254] Vyatchin A.V.: On the convergence of Padé approximants. *Moscow Univ. Math. Bull.*, 37(4), 1–4 (1982).
- [255] Wasov W.: *Asymptotic Expansions for Ordinary Differential Equations*. John Wiley and Sons, Inc., New York, 1965.
- [256] Whitham G.B.: *Linear and Nonlinear Waves*. John Wiley and Sons, Inc., New York, 1974.
- [257] Yudovich V.I.: Vibrodynamics and vibrogeometry of mechanical systems with couplings. *Advances in Mechanics*, 3(1), 26–74 (2006) (in Russian).
- [258] Weniger E.I.: Nonlinear sequence transformations for the acceleration of convergence and the summation of divergent series. *Comp. Phys. Rep.*, 10, 189–371 (1989).
- [259] Wiener O.: Die Theorie des Mischkörpers für das Feld der stationären Strömung. Erste Abhandlung die Mittelwertsätze für Kraft, Polarisation und Energie. *Der Abhandlungen der Mathematisch-Physischen Klasse der Königlich Sächsischen Gesellschaft der Wissenschaften*, 32, 509–604 (1912).
- [260] Zaslavskiy G.M., Usikov D. A., Sagdeev R.Z.: *Nonlinear Physics: From the Pendulum to Turbulence and Chaos*. Harwood Ac. Publ., New York, 1988.
- [261] Joukowsky N.E.: The work of continuous and non-continuous traction devices in pulling a train from its position and at the beginning of its motion. In *Complete Collected Works, 8: Theory of Elasticity. Railways. Automobiles*, 221–55, ONTI, Moscow (1937) (in Russian).

