

1

Introduction to Steam Turbines

1.1 Why Do We Use Steam Turbines?

Steam turbine drivers are prime movers that convert the thermal energy present in steam into mechanical energy through the rotation of a shaft. Industrial steam turbines fit into one of two general categories: generator drives and mechanical drives. Generator drives include all turbines driving either synchronous or induction generators for power generation. In this book, we will cover primarily steam turbines used in the petrochemical industry as mechanical drives for centrifugal pumps and centrifugal compressors. In mechanical drives, the rotational energy is transmitted to a process machine that in turn

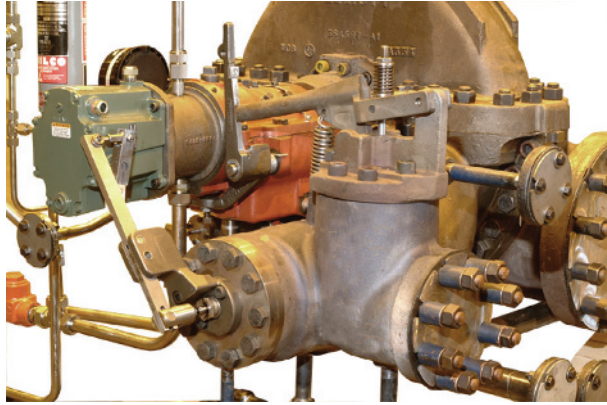

Figure 1.1 General purpose steam turbine. (Courtesy of Elliott Group)

converts it into fluid energy required to provide flow for a given process.

Heat energy → Steam energy → Rotational energy → Fluid energy

1.2 How Steam Turbines Work

Steam turbines are relatively simple machines that use high-velocity steam jets to drive a bladed wheel that is attached to a rotating shaft. Figure 1.2 depicts an impulse-type steam turbine in its most basic form: A steam nozzle and a bucketed, rotating wheel.

In this design, high-pressure steam is accelerated to a high velocity in the stationary nozzle and then directed onto a set of blades or buckets attached to a wheel. As the steam jet impacts the buckets, it is deflected and then leaves the scene. The change in

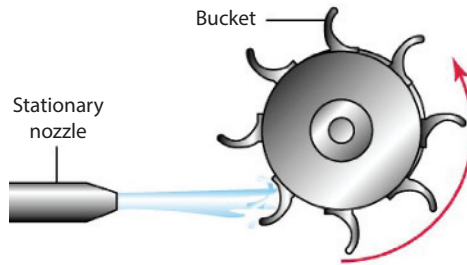

Figure 1.2 Basic impulse steam turbine.

momentum involved in the steam's deflection generates a force that turns the wheel in the direction opposite of the incoming steam jet. If the wheel is affixed to a shaft and supported by a set of bearings, rotational power can be transmitted via the output shaft.

To produce useful work in a safe and reliable manner, an impulse-type steam turbine, at a minimum, must contain:

1. A bladed wheel that is attached to a shaft.
2. A set of stationary steam nozzles capable of accelerating high-pressure steam to create high velocity jets. (See the steam nozzle in Figure 1.3.)
3. A pressure-containing casing.
4. Seals that can control steam leakage from traveling down the shaft. (See carbon packing end seals in Figure 1.3.)
5. A governor system capable of controlling rotating speed within design specifications. (Speed governor in Figure 1.3.)

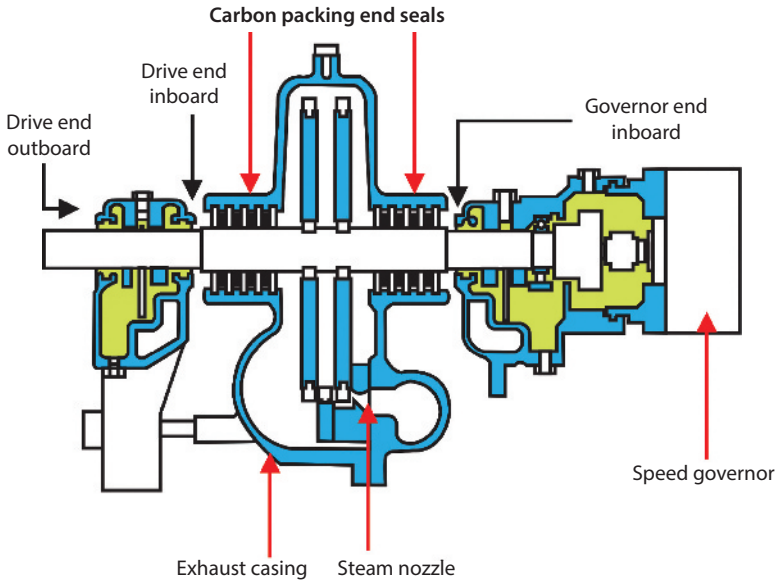

Figure 1.3 Cross section of an impulse steam turbine.

Governor systems fall into two main categories: hydraulic and electronic.

6. A coupling that can transmit power from the steam turbine to an adjacent centrifugal machine.

Steam turbines can be rated anywhere from a few horsepower to around a million horsepower. They can be configured to drive generators to produce electricity, or mechanical machines such as fans, compressors, and pumps. Steam turbines can be designed to operate with a vertical or horizontal rotor, but are most often applied with horizontal rotors.

1.2.1 Steam Generation

Steam is either generated in a boiler or in a heat recovery steam generator by transferring the heat from combustion gases into water. When water absorbs enough heat, it changes phase from liquid to steam. In some boilers, a super-heater further increases the energy content of the steam. Under pressure, the steam then flows from the boiler or steam generator and into the distribution system.

1.2.2 Waste Heat Utilization

Waste heat conversion is the process of capturing heat discarded by an existing industrial process and using that heat to generate low-pressure steam. Energy-intensive industrial processes—such as those occurring at refineries, steel mills, glass furnaces, and cement kilns—all release hot exhaust thermal energy in the form of hot liquid streams that can be captured using waste heat boilers (see Figure 1.4).

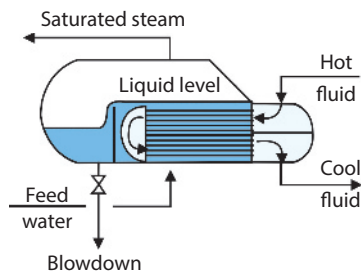

Figure 1.4 Waste heat boiler.

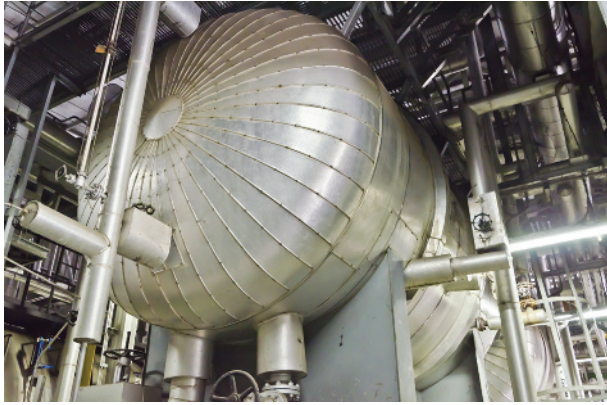

Figure 1.5 Steam drum.

The steam from waste heat boilers can be utilized for heating purposes or to power steam turbines.

Steam systems all tend to have the following elements:

- Boiler—A process subsystem that uses a fired fuel or waste heat to turn condensate into high-pressure steam. Steam is typically collected in a steam drum (see Figure 1.5)
- Steam Turbine—A rotating machine that converts high-pressure steam energy into shaft power
- Process Waste Heat Recovery or Condenser—A part of the process that recovers sufficient lower pressure steam heat to condense all the steam back to condensate

- **Boiler Feedwater Pump**—A liquid pump that raises condensate pressure back to boil pressure so that it can be returned to the steam boiler

1.2.3 The Rankine Cycle

The Rankine cycle is the thermodynamic basis for most industrial steam turbine systems. It consists of a heat source (boiler) that converts water to high-pressure steam. In the steam cycle, water is first pumped up to elevated pressure and sent to a boiler. Once in the boiler, liquid water is then heated to the boiling temperature corresponding to the system pressure until it boils, i.e., transforms from a liquid into water vapor. In most cases, the steam is superheated, meaning it is heated to a temperature above that required for boiling. The pressurized steam is: (a) transmitted via piping to a multistage turbine, where it is (b) expanded to lower pressure and then (c) exhausted either to a condenser at vacuum conditions or into an intermediate temperature steam distribution system. Intermediate pressure steam is often used for other process applications at a nearby site. The condensate from the condenser or from the industrial steam utilization system is returned to the feedwater pump for continuation of the cycle.

Primary components of a boiler/steam turbine system are shown in Figure 1.6.

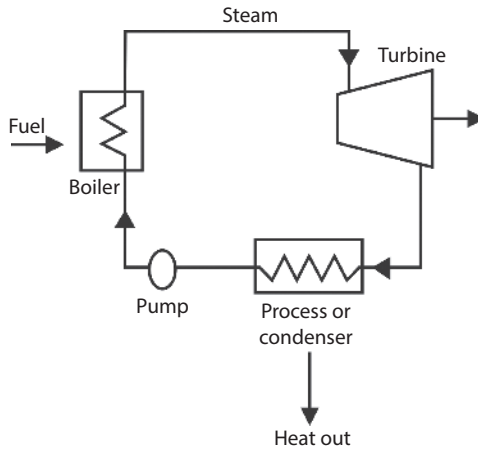

Figure 1.6 Components of a boiler/steam turbine system.

1.3 Properties of Steam

Water can exist in three forms, ice, liquid and gas. If heat energy is added to water, its temperature will rise until it reaches the point where it can no longer exist as a liquid. We call this temperature the “saturation” point, where with any further addition of heat energy, some of the water will boil off as gaseous water, called steam. This evaporation effect requires relatively large amounts of energy per pound of water to convert the state of water into its gaseous state. As heat continues to be added to saturated water, the water and the steam remain at the same temperature, as long as liquid water is present in the boiler.

The temperature at which water boils, also called boiling point or saturation temperature, increases as the pressure in the vapor space above the water



Figure 1.7 Tea kettle producing steam.

increases. As the water vapor pressure increases above the atmospheric pressure, its saturation temperature rises above 212 °F. The table below titled, “Properties of Saturated Steam” illustrates how the saturated steam temperature increases with increasing steam pressure.

If heat is added after the steam has left the boiler, without an increase in steam pressure, superheated steam is produced. The temperature of superheated steam, expressed as degrees above saturation corresponding to the pressure, is referred to as the degrees of superheat. Adding superheat to steam is a good way to prevent steam from condensing as it makes its way from a boiler to a steam turbine.

In general, we can say that the higher the steam pressure and its corresponding temperature the more energy it contains to perform useful work. In order to get a feel for typical saturated steam pressure and

temperature, we will provide a few realistic examples. Refer to the “Properties of Saturated Steam” (Table 1.1) as you consider the following examples:

Example #1:

Let's assume we have a boiler operating at 265 psia or 250.3 psig (psia = psig + 14.7). If water in a boiler

Table 1.1 Properties of saturated steam.

Absolute pressure (psia)	Gauge pressure (psig)	Steam temp. (°F)	With 10 degrees superheat
165	150.30	365.99	375.99
175	160.30	370.75	380.75
195	180.30	379.67	389.67
215	200.30	387.89	397.89
240	225.30	397.37	407.37
265	250.30	406.11	416.11
300	285.30	417.33	427.33
400	385.30	444.59	454.59
450	435.30	456.28	466.28
500	485.30	467.01	477.01
600	585.30	486.21	496.21
900	885.30	531.98	541.98
1200	1185.30	567.22	577.22
1500	1485.30	596.23	606.23
1700	1685.30	613.15	623.15
2000	1985.30	635.82	645.82

is at saturated, steady-state conditions, we can expect the steam exiting the boiler to be at 406.11 °F. If we are able to add 10 degrees of superheat, we would have a steam temperature of $406.11 + 10 = 416.11$ degrees.

Example #2:

Let's assume we have a boiler operating at 600 psia or 585.3 psig. If water in a boiler is at saturated, steady-state conditions, we can expect the steam exiting the boiler to be at 486.21 °F. If we are able to add 10 degrees of superheat, we would have a steam temperature of $486.21 + 10 = 496.21$ degrees.

Question:

What steam temperature should you expect on a system operating at 1200 psia with 10 degrees of superheat?

Answer:

By inspection, you should expect to see a steam temperature of 577.22 °F.

Note: Appendix D contains additional steam property data.

1.3.1 Turbine Design Configurations

The potential steam-related energy available for a steam turbine is directly proportional to the differential pressure between the supply and the exhaust steam. The greater the pressure differential and the

greater the superheat, the more work the steam turbine can perform. There are three categories of steam turbines aimed at extracting horsepower for various steam configurations. They are condensing, back pressure, and extraction types (refer to Figures 1.8 and 1.9): Condensing turbines use a surface condenser to convert steam from its gaseous state into its liquid state at a pressure below atmospheric pressure. Back pressure steam turbines are designed to exhaust into steam systems that operate above atmospheric pressure. Extraction type steam turbines have the ability to “extract” a percentage of the total inlet steam flow at some intermediate pressure as required by the plant.

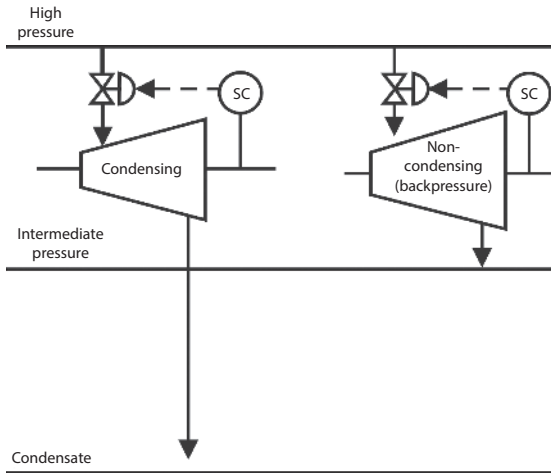

Figure 1.8 Condensing steam turbine (on the left) and non-condensing steam turbine (on the right). Notice that the non-condensing steam turbine exhausts into an intermediate pressure steam header.

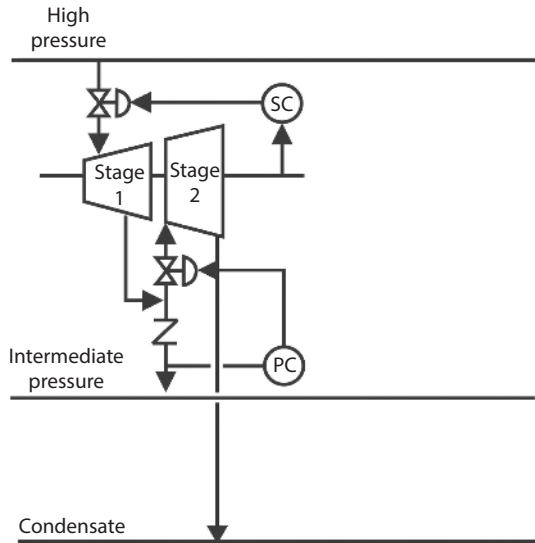

Figure 1.9 Extraction type steam turbine.

1.4 Steam and Water Requirements

1.4.1 Steam Conditions for Steam Turbines

The turbine's supply steam should be either superheated or at least very dry to prevent the erosion of the turbine blades. The internal nozzles, diaphragms, and casing can also be affected by erosion due to poor steam quality.

1.4.2 Water Conditions for Steam Turbines

It is important for boiler feed water to be monitored to insure its quality. When the quality is out of specifications, it can create not only problems for the boiler but for all of the steam users downstream. The turbine of course is one of the users of produced

steam. Improper water quality can cause erosion and deposition on piping and turbine blades. Carryover of improperly treated water can coat turbine blades, potentially affecting produced power and causing rotor vibration.

1.4.3 Advantages of Steam Turbine Drives

Steam turbines found throughout petrochemical facilities are frequently used in critical process applications for the following reasons:

- Steam turbines can operate independently of the plant's electrical system. This is a vital requirement for processes that cannot tolerate upsets or trips due to electrical outages. Here are two applications where

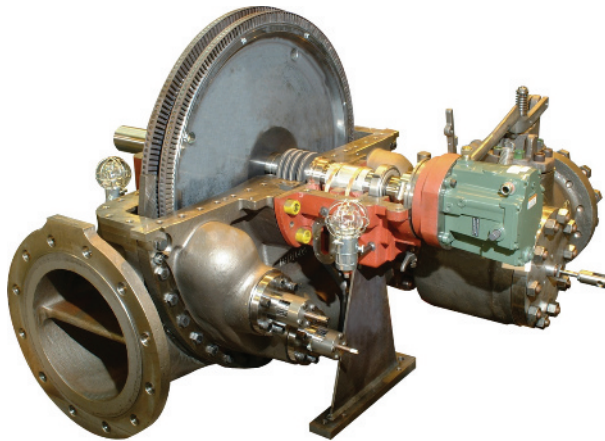

Figure 1.10 General purpose steam turbine. (Courtesy of Elliott Group)

maintaining a constant flow is critical:
1) Sustaining process flow to a heater that may “coke-up” heater tubes if flow is lost or
2) Maintaining compressor recycle flow across a catalyst bed to prevent poisoning of the catalyst.

- Steam turbines can provide variable speed capability. Variable speed capabilities are useful whenever variable flow or pressures are required to deal with changing conditions. Variable speed capabilities can be useful during start-up conditions when process flows, pressure, or fluid properties are different from design conditions.
- Steam turbines can be employed to optimize the plant-wide steam usage. In some production sites, steam is generated by the process and is needed at different pressure levels throughout the plant. Instead of wasting energy by using pressure-reducing valves to balance out the flow of steam at different pressures, steam turbines can be used to drop pressures while converting the steam power into useful horsepower as a mechanical driver. In some cases, the steam can be used to drive a generator and the electricity can be used to drive electric motors elsewhere in the plant.
- Steam turbines will not stall or trip on overload. Whenever process conditions

lead to a high driver load, the steam turbine will slow down, but will not trip. This capability allows steam turbines to better handle upset conditions.

- Other steam turbine advantages include:
 - They offer high horsepower ratings in a small package
 - They are non-sparking and explosion proof
 - They can be designed for remote starting

1.4.4 Speed Control

Governing of a steam turbine is the procedure of monitoring and controlling the flow rate of steam into the turbine with the objective of maintaining a constant speed of rotation. The flow rate of steam is monitored and controlled by a throttling valve between the boiler and the turbine. Depending upon the particular method adopted for control of steam flow rate, different types of governing methods are being practiced.

The control of a turbine with a governor is a critical function, as turbines need to be run up slowly to prevent damage. If this fails, then the turbine may continue accelerating until it breaks apart, often catastrophically. Turbines are expensive to produce, requiring precision manufacturing methods and special quality materials.

Steam turbine controls consist of two linked control systems, the governor and the valve operator. The governor is a specialized closed loop controller that maintains an adjustable set point speed or load on the turbine. The valve operator accepts the governor's output demand and closes a position loop for steam admission valve as commanded by the governor. Control valves are employed to regulate the flow of steam to the turbine for starting, increasing or decreasing power, and maintaining speed control with the turbine governor system. Several different valve arrangements are utilized.

Note: Steam control valves need to be cycled routinely to minimize the potential for the valves to stick. When the valves stick open or closed, the turbine is put into jeopardy as a result of losing the ability to control the turbine (i.e., increase or reduce load).

1.4.5 Turbine Overspeed Protection

Potentially, the most destructive event in the life of a steam turbine is an overspeed event, which occurs where the steam turbine and its driven equipment accelerate to an uncontrolled, unsafe speed due to a failure in the control system or the failure of a coupling. Inevitably, overspeed events can result in catastrophic machine damage, and can on rare occasion injure those who have the misfortune of being nearby during an overspeed occurrence.

Overspeed events, while infrequent, continue to occur on both small and larger steam turbines regardless of the vintage, technology level, application, or type of control system (digital, analog, hydro-mechanical, mechanical) utilized by the steam turbine. A steam turbine may employ a mechanical overspeed protection system, electronic overspeed protection system, or combination of systems to maximize protection.

Note: Regardless of the type of overspeed and trip protection systems provided, the system needs to be regularly tested by simulation and by actual testing of the complete system.

During normal shutdowns, always slow the steam turbine down and trip it off-line using the trip mechanism. This ensures the trip system is working and that the stop valve will actuate.

Questions

1. Industrial steam turbines fit into what two general drive categories?
2. The _____ cycle is the thermodynamic basis for most industrial steam turbine systems.
3. One key advantage of steam turbines is they can operate independently of the plant's _____ system.

4. A _____ (two words) steam turbine is designed to exhaust into steam systems that operate above atmospheric pressure.
5. Potentially, the most destructive event in the life of a steam turbine is an _____ event.

Answers

1. Industrial steam turbines fit into what two general drive categories?
Generator drives and mechanical drives
2. The _____ Rankine _____ cycle is the thermodynamic basis for most industrial steam turbine systems.
3. One key advantage of steam turbines is they can operate independently of the plant's _____ electrical _____ system.
4. A _____ back _____ pressure _____ (two words) steam turbine is designed to exhaust into steam systems that operate above atmospheric pressure.
5. Potentially, the most destructive event in the life of a steam turbine is an _____ overspeed _____ event.

