

Chapter 1

Mathematical Reasoning

The GED's mathematics section lasts 115 minutes and contains 50 questions divided into two parts: a calculator-allowed part and a no-calculator-allowed part. The no-calculator-allowed questions tend to be less math-heavy and more concept-based, whereas the calculator-allowed questions tend to be more challenging and require more calculations. In this chapter, you get 285 questions to practice your math skills.

The Problems You'll Work On

The mathematics section focuses on the following content areas for both the calculator and no-calculator parts:

- » Number operations and number sense
- » Measurement and geometry
- » Data analysis, statistics, and probability
- » Algebra, functions, and patterns

What to Watch Out For

To increase your accuracy and improve time management, avoid these snags:

- » Making mistakes in simple math, such as improperly subtracting negative numbers
- » Spending more than a couple of minutes on any one problem instead of marking time-consuming questions and returning to them later
- » Failing to review key formulas and concepts from all math areas
- » Engaging in complex calculations when you can instead apply time-saving strategies such as trying answer choices and plugging in values for variables

- If $f(x) = 2x - 3$, what is the value of $f(x)$ when x is -5 ?
 - -13
 - -7
 - 7
 - 11
- What is the correct way of writing “ x is less than 5 but greater than or equal to -3 ”?
 - $x - 5 \geq -3$
 - $5 - x \geq -3$
 - $-3 \leq x < 5$
 - $-3 \geq x > 5$
- If $x^2 + 3x = 10$, which of the following is a possible value of x ?
 - -2
 - 5
 - 7
 - -5
- Jim rented a lawnmower from 9:00 a.m. until 5:30 p.m. He paid a total of \$53.04. What was the hourly rental fee? (*Note:* You may *not* use a calculator for this problem.)
 - \$5.58
 - \$6.24
 - \$6.63
 - \$7.07
- What is the value of $6x - 3y^2$ when $x = 12$ and $y = -5$?
 - -153
 - 297
 - -3
 - 147
- Alex earns a weekly base salary of \$650 as a car salesman. He also earns a 9% commission on his monthly sales after the first \$10,000. What was his total salary this month if he sold 7 cars whose average price was \$4,500 each?
 - \$1,935
 - \$2,585
 - \$2,835
 - \$3,485
- Simplify the expression completely.

$$\sqrt{20} \cdot \sqrt{10}$$
 - $5\sqrt{2}$
 - $\sqrt{200}$
 - $2\sqrt{10}$
 - $10\sqrt{2}$
- A human hair has an average diameter of 2.5×10^{-5} meters. What is the maximum number of human hairs that could fit side by side (without overlapping) on a microscope slide that is 50 millimeters wide? Write your answer in scientific notation.
 - 2.0×10^3
 - 2.0×10^5
 - 2×10^6
 - 10^{-3}
- Bob is planning a birthday party for his son and has a maximum budget of \$475 to spend. He intends to rent a party room that costs \$125 for the day. He expects a total of 35 people to attend the party and plans to provide them all with lunch. Which of the following inequalities shows how to calculate the amount x that Bob can spend on lunch for each person?
 - $125x + 35 \geq 475$
 - $125x + 35 \leq 475$
 - $125 + 35x \geq 475$
 - $125 + 35x \leq 475$

- 10.** Four years ago, Jenny’s annual salary was \$22,625. This year, her salary was \$32,433. What will her new salary be in 5 years if it continues to rise at the same linear rate?
- (A) \$34,885
 (B) \$42,241
 (C) \$44,693
 (D) \$55,058
- 11.** Mr. White’s math class has n students. Mrs. Black’s math class has 22 students fewer than triple the number of students in Mr. White’s class. Which expression shows the number of students in Mrs. Black’s class in terms of n ?
- (A) $22 < 3n$
 (B) $3(n - 22)$
 (C) $22 - 3n$
 (D) $3n - 22$

Questions 12 through 14 are based on the following information.

Denise measures the height of a sunflower every other week over a three-month period and records the results in the following table.

Weeks	Height (in cm)
1	3.00
3	4.70
5	6.40
7	8.10
9	9.80
11	11.50
13	13.20

- 12.** Denise plots the data on a coordinate grid. She begins by plotting the data for Week 3 and Week 11.
- What are the coordinates of the two points that Denise plots?
- (A) (11,3) and (11.5, 4.7)
 (B) (3, 11) and (4.7, 11.5)
 (C) (3, 4.7) and (11, 11.5)
 (D) (4.7, 3) and (11.5, 11)
- 13.** Denise creates an equation that will allow her to predict the height of the sunflower in the future, where x is the week and y is the height. Which of the following gives the correct equation?
- (A) $y = 0.85x + 2.15$
 (B) $y = 1.7x + 2.15$
 (C) $y = 0.85x + 1.3$
 (D) $y = 1.7x + 1.3$
- 14.** If the sunflower continues to grow at the same rate, at what week will it reach a height of 16.6 cm?
- (A) Week 15
 (B) Week 17
 (C) Week 19
 (D) Week 21

15. A doctor measured the blood sugar levels of one of her patients shortly after giving the patient a candy bar to eat. The graph below shows the patient's blood sugar level (y) x hours after she ate the candy bar.

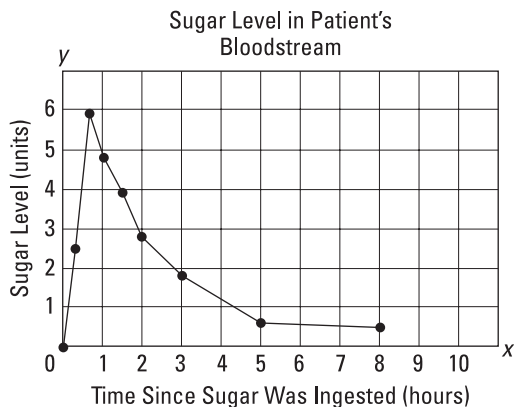

How long after eating the candy bar was the patient's blood sugar level the highest?

- (A) 20 minutes
 (B) 30 minutes
 (C) 40 minutes
 (D) 1 hour
16. A candy store sells soda in cone-shaped cups with the dimensions shown here:

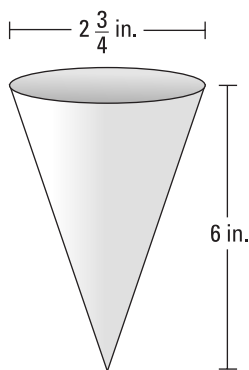

What volume of soda can each cup hold? Give your answer to the nearest tenth of a cubic inch. The formula for the volume V of a cone with radius r and height h is $V = \frac{1}{3}\pi r^2 h$.

- (A) 11.8
 (B) 11.9
 (C) 47.5
 (D) 142.5
17. Anne plans to spend no more than \$60 ordering socks for school. The online sock company charges a shipping fee of \$15 for any order. The inequality $15 + 5x \leq 60$ represents the number of pairs of socks Anne can order from the company. What is the maximum number of pairs of socks that Anne can buy?

Questions 18 and 19 are based on the following information.

Ten students took a math quiz that consisted of 10 questions. The median score was 5.5. The modal score was 6. The teacher recorded the results of the first nine students in the following line plot.

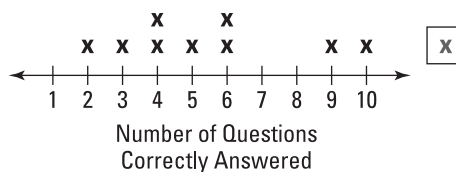

18. What was the average score of the first nine students whose scores were represented on the line plot? Give your answer to one decimal place.
- (A) 4.9
 (B) 5.4
 (C) 5.5
 (D) 5.7

19. What score did the tenth student get in the quiz?
- (A) 4
(B) 5
(C) 6
(D) 7

Questions 20 through 22 are based on the following information.

The probability that it will snow during the next three days is given in the following table.

Day	Monday	Tuesday	Wednesday
Probability of snow	70%	20%	40%

20. What is the probability that it will *not* snow on Tuesday?
- (A) 20%
(B) 40%
(C) 60%
(D) 80%
21. What is the probability that it will snow on all three days?
- _____
22. What is the probability that it will snow on two out of three days? Round your answer to the nearest whole number.
- (A) 33%
(B) 43%
(C) 90%
(D) 130%

23. Using the information in the following chart, estimate to the nearest thousand the total number of tickets sold at the concert hall. (*Note:* You may *not* use a calculator.)

Concert	Tickets Sold
The Ghastly Girls	4,721
Two Directions	5,301
Taylor Speedy	8,783
Maroon 6	270
The Subdominants	11,802

- (A) 27,000
(B) 29,000
(C) 31,000
(D) 31,877
24. Egypt's Great Pyramid is 150 m tall and has a square base with a length of 225 m. What is the approximate volume of the pyramid in cubic meters? The formula for the volume V of a pyramid of base area B and height h is given by $V = \frac{1}{3}Bh$.
- (A) 500,000
(B) 1,500,000
(C) 2,500,000
(D) 7,500,000

Questions 25 through 27 are based on the following set.

Set A: {41, 51, 61, 71, 81, 91, 101}

25. What is the range of Set A?
- (A) 41
(B) 60
(C) 71
(D) 142

26. What is the median of Set A?
- (A) 41
(B) 60
(C) 71
(D) 142
27. What is the arithmetic mean (average) of Set A?
- (A) 41
(B) 60
(C) 71
(D) 142
28. Four hundred eighty yards is what fraction of a mile? (1 mile = 1,760 yards)
- (A) $\frac{27}{100}$
(B) $3\frac{2}{3}$
(C) $\frac{2}{5}$
(D) $\frac{3}{11}$
29. Tim measures the lengths of four cats' tails and records his results in the following table.

Cat	Tail Length (Inches)
Mrs. Whiskers	$7\frac{3}{4}$
Bootsie	$7\frac{3}{8}$
Mr. Bigglesworth	$7\frac{11}{16}$
Catty McCatface	$7\frac{25}{32}$

Which cat has the longest tail? (Note: You may *not* use a calculator.)

- (A) Mrs. Whiskers
(B) Bootsie
(C) Mr. Bigglesworth
(D) Catty McCatface

30. The U.S. Senate has 100 senators. In 2015, only 20 senators were female. What is the ratio of female senators to male senators? (Note: You may *not* use a calculator.)
- (A) 1:5
(B) 1:4
(C) 4:5
(D) 4:1
31. Alex test drives four cars and records the distance traveled and the gallons of gas used in each case in the following table.

Car	Distance Driven (Miles)	Gas Used (Gallons)
A	102.3	11.5
B	78.1	7.9
C	57.8	6.2
D	142.9	15.9

Which car has the best gas mileage (miles per gallon)?

- (A) Car A
(B) Car B
(C) Car C
(D) Car D

Questions 32 and 33 are based on the following information.

A fair die has six sides, each marked with a different integer from 1 to 6. Each side is equally likely to land face up when the die is rolled.

32. Suppose you roll the die 66 times. How many times are you likely to roll a 6?
- (A) 6
(B) 11
(C) 55
(D) 66

- 33.** Suppose you roll the die three times. What is the probability of not rolling any 1s during the three rolls? Express your answer as a fraction reduced to its lowest terms.
-

- 34.** Monthly sales of a particular brand of smartphone are inversely proportional to the number of occurrences of exploding cellphone batteries during that month. If 88 million phones were sold when there were 2 exploding batteries, how many cell phones would be sold during a month in which 22 batteries exploded?

- (A) 4 million
(B) 8 million
(C) 44 million
(D) 176 million

- 35.** The scale on a blueprint for a boat is 2 cm = 5 meters. If the length of the boat on the blueprint measures 7.5 cm, how long is the actual boat?

- (A) 12.50 m
(B) 15.25 m
(C) 18.75 m
(D) 20.25 m

- 36.** A New York City taxi charges an initial fee of \$2.50 plus \$0.50 for every $\frac{1}{5}$ of a mile traveled. If Jim's total fare (not including tip) equals \$14.50, how many miles did Jim travel?

- (A) 4.8 miles
(B) 5.8 miles
(C) 24 miles
(D) 29 miles

- 37.** Arnold invested \$700 in a savings account. After one year, his account balance was \$726.25. What percent annual interest did his bank pay?
-

Questions 38 and 39 are based on the following information.

At Becky's Burger Shack, cooks earn an average of \$950 per week, whereas waiters earn an average of \$725 per week. Let x and y equal the number of cooks and waiters, respectively, employed by the restaurant.

- 38.** Which of the following functions represents the total payroll (P) that Becky's restaurant pays for all of these types of workers?

- (A) $P = 950y + 725x$
(B) $P = (950x)(725y)$
(C) $P = 950x + 725y$
(D) $P = (x + y)(950 + 725)$

- 39.** Becky employs 5 cooks and can spend no more than \$9,825 per week on the payroll for all her cooks and waiters. What is the maximum number of waiters that she can employ?

- (A) 3
(B) 5
(C) 7
(D) 9

- 40.** If $\frac{2}{7}x = 31$, what does $\frac{4}{7}x$ equal?

- (A) 15.5
(B) 62
(C) 108.5
(D) 217

Questions 41 and 42 are based on the following information.

A moving company rents small or large vans for a fixed fee of \$80 and \$125, respectively, plus \$3.75 per mile driven. The company also offers professional movers at a rate of \$18 per mover per hour.

41. Sid rents a large van with 3 professional movers for 5 hours and drives a total of 42 miles. How much will the company charge him (not including tips or taxes)?
- _____
42. Jenny's moving bill was \$450 before taxes and tips. If taxes are 6% and she also wants to tip her three professional movers \$20 each, what does her total bill equal?
- (A) \$497
(B) 498.20
(C) \$537
(D) \$540.60

Questions 43 through 45 are based on the following graph.

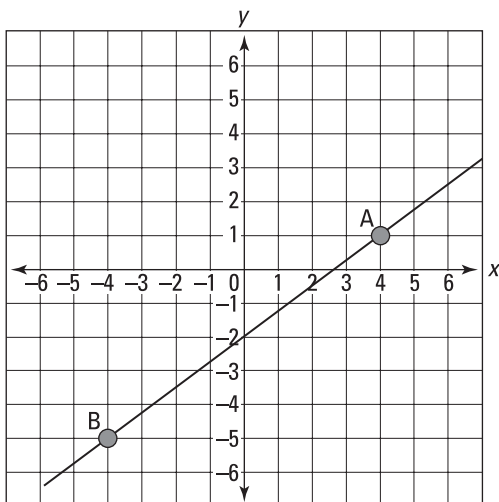

43. What are the coordinates of point A?
- (A) (4, 1)
(B) (1, 4)
(C) (-5, -4)
(D) (-4, -5)
44. What is the slope of the line?
- (A) $\frac{4}{3}$
(B) $\frac{3}{4}$
(C) $-\frac{3}{4}$
(D) $\frac{2}{3}$
45. What is the equation of the line?
- (A) $y = \frac{4}{3}x - 2$
(B) $y = \frac{3}{4}x - 2$
(C) $y = -2x + \frac{3}{4}$
(D) $y = -2x + \frac{4}{3}$
46. A car dealership offers 45% off all its cars during its annual sale. Jessica pays \$7,150 for her discounted vehicle. What was the original price of the car? Round your answer to the nearest dollar.
- (A) \$3,933
(B) \$10,368
(C) \$13,000
(D) \$15,889
47. On a sunny day, a tree casts a shadow that is 33 feet long. At the same time, a nearby 4-foot-tall mailbox casts a shadow that is 5.5 feet long. What is the height of the tree? Round your answer to the nearest foot.
- (A) 24 feet
(B) 33 feet
(C) 38 feet
(D) 45 feet

48. The hypotenuse of a right triangle is 17 inches. If one of the legs of the triangle is 8 inches long, what is the length of the other leg?
- (A) 8 inches
 (B) 12 inches
 (C) 15 inches
 (D) 19 inches

Questions 49 through 51 are based on the following graph.

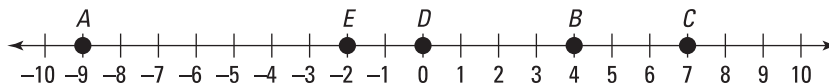

49. What is the value of A minus E?
- (A) -13
 (B) -11
 (C) -7
 (D) 7
50. What is the product of A times C times D times E?
- (A) -126
 (B) 0
 (C) 63
 (D) 126
51. Which of the following is true?
- (A) $|A| < |C|$
 (B) $|D| > |E|$
 (C) $-|E| < A$
 (D) $-A > |E| + |B|$
52. If $x^2 - 5x = 24$, which of the following is a possible value of x ?
- (A) -8
 (B) 3
 (C) 8
 (D) 24
53. $(x + y)^2$ is equivalent to which of the following?
- (A) $x^2 + y^2$
 (B) x^2y^2
 (C) $x^2 + y^2 + 2xy$
 (D) $2x + 2y$
54. A cube has a surface area of 216 square inches. What is its volume in cubic inches?
- (A) 6
 (B) 36
 (C) 108
 (D) 216
55. $\sqrt{162}$ is equivalent to which of the following?
- (A) $3\sqrt{2}$
 (B) $9\sqrt{2}$
 (C) $54\sqrt{3}$
 (D) $2\sqrt{81}$
56. $\sqrt{129}$ is between which numbers?
- (A) 10 and 11
 (B) 11 and 12
 (C) 14 and 15
 (D) 64 and 65

Questions 57 through 59 are based on the following information.

Steven bought a bag of nuts containing 15 almonds, 3 peanuts, 12 cashews, and 10 pistachios.

- 57.** What fraction of the nuts were cashews? Reduce your answer to its lowest terms.
- (A) $\frac{12}{40}$
(B) $\frac{3}{40}$
(C) $\frac{3}{10}$
(D) $\frac{5}{20}$
- 58.** Steven takes 2 nuts out of the bag without looking at them or replacing them. What is the probability that both of the nuts are peanuts? Reduce your answer to its lowest terms.
- (A) $\frac{1}{20}$
(B) $\frac{3}{40}$
(C) $\frac{5}{79}$
(D) $\frac{1}{260}$
- 59.** If the bag of nuts cost Steven \$5.20, what was the average cost per nut?
- (A) \$0.08
(B) \$0.11
(C) \$0.13
(D) \$0.17
- 60.** Solve the following equation for x :
 $19 - 2x = -1$
- _____

Questions 61 and 62 are based on a line whose equation is given by the following:

$$y - 4x = 13$$

- 61.** Point A lies on the line. If the y -coordinate of point A is 5, what is the value of the corresponding x -coordinate?
- (A) -7
(B) -2
(C) 3
(D) 33
- 62.** Fill in the blanks by choosing the correct values from the brackets:
- The value of the slope of the line is _____ $[-13, -4, 4, 13]$, and the value of the y -intercept is _____ $[-13, -4, 4, 13]$.
- 63.** A company manufactures light bulbs. If 1 out of 25 light bulbs produced by the company is found to be defective, how many defective light bulbs will there be in a batch of 3,075 light bulbs?
- (A) 25
(B) 123
(C) 500
(D) 76,875

Questions 64 through 66 are based on the following rectangle.

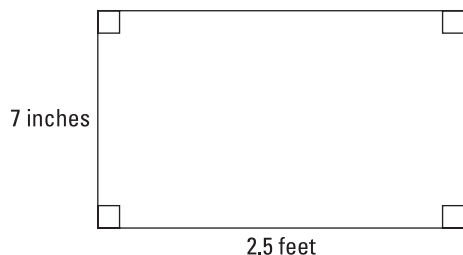

- 64.** What is the area of the rectangle? (Give your answer to the nearest square inch.)
- (A) 10
 (B) 17
 (C) 18
 (D) 210
- 65.** If the rectangle were enlarged by a factor of 3 (so that its sides became 3 times as long as they were previously), what would be the ratio of the new perimeter to the old perimeter?
- (A) 1:3
 (B) 1:9
 (C) 3:1
 (D) 9:1
- 66.** If rectangle $ABCD$ were enlarged by a factor of 3 (so that its sides became 3 times as long as they were previously), what would be the ratio of the new area to the old area?
- (A) 1:3
 (B) 1:9
 (C) 3:1
 (D) 9:1

- 67.** What is the decimal equivalent of $\frac{3}{8}$? (Note: You may *not* use a calculator.)
- _____

- 68.** What is the sum of $2.8 \times 10^5 + 1.7 \times 10^4$? (Note: You may *not* use a calculator.)
- (A) 4.5×10^5
 (B) 4.5×10^9
 (C) 2.97×10^4
 (D) 2.97×10^5

- 69.** What is the product of $(8 \times 10^6) \times (4 \times 10^{-3})$? Write your answer in scientific notation. (Note: You may *not* use a calculator.)
- (A) 3.2×10^{-17}
 (B) 3.2×10^2
 (C) 32×10^3
 (D) 3.2×10^4

- 70.** Select from the options to correctly fill in the blanks.

Two lines that never meet are called _____ lines, and their slopes are _____. Two lines that meet at right angles are called _____ lines, and their slopes are _____.

Options:

- parallel
 perpendicular
 equal
 negative reciprocals

Questions 71 through 73 are based on the following information.

The average price of a gallon of gasoline increased in a linear fashion over a 4-week period as shown in the table.

Week	Price (\$ per Gallon)
Week 1	\$3.29
Week 2	\$3.38
Week 3	\$3.47
Week 4	\$3.56

71. What is the range of the prices in the table? (Round your answer to the nearest cent.)
- _____
72. What is the average price of a gallon of gasoline during the given 4-week period? (Give your answer to the nearest cent.)
- (A) \$3.42
(B) \$3.43
(C) \$3.51
(D) \$3.52
73. If the average price of a gallon of gasoline continues to rise at the same rate, what will 3 gallons of gasoline cost during Week 8?
- (A) \$3.92
(B) \$4.24
(C) \$7.51
(D) \$11.76

Questions 74 through 76 are based on the following information.

$$x = p^7, y = p^{-3}, \text{ and } z = \frac{1}{p}$$

74. Which of the following expresses $\left(\frac{x}{y}\right)^2$ in terms of p ?
- (A) p^8
(B) p^{10}
(C) p^{20}
(D) p

75. Which of the following expresses $\left(\frac{x^2 \cdot y^4}{z^3}\right)^0$ in terms of p ?
- (A) 0
(B) 1
(C) p^{-5}
(D) p

76. Which of the following expresses $(x)(y)^2(z)$ in terms of p ?
- (A) 1
(B) p
(C) p^7
(D) p^9

77. $f(x) = \frac{10 - x^2}{x^2}$

What is the value of $f(x)$ when x is -3 ?

- (A) 9
(B) 10
(C) $\frac{1}{9}$
(D) $\frac{19}{9}$

Questions 78 through 80 are based on the following diagram, which shows a pair of parallel lines crossed by a transversal line.

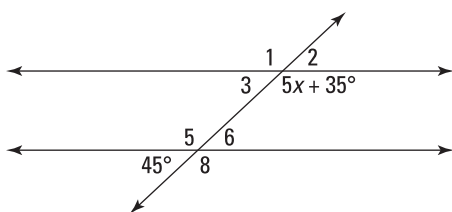

- 78.** Select from the options to correctly fill in the blanks.

Angle 2 is a/an _____ angle and is _____ to angle 1. Angle 5 is a/an _____ angle and is _____ to angle 8.

Options:

acute
obtuse
reflex
complementary
supplementary
congruent

- 79.** What is the measure of angle 1? (*Note:* You may *not* use a calculator.)

(A) 45°
(B) 125°
(C) 135°
(D) 145°

- 80.** What is the value of x ?

- 81.** A boat's sail is in the shape of an isosceles triangle. If the largest angle of the sail is 90° , what is the measure of the smallest angle in degrees?

- 82.** The angles of a triangle are in a ratio of 5 : 9 : 14. What is the measure of the largest angle?

(A) 25°
(B) 45°
(C) 90°
(D) 140°

- 83.** A recipe for cookies calls for $\frac{3}{8}$ cup of brown sugar to make 2 dozen cookies. If Sasha has 4.5 cups of brown sugar available and enough of all the other ingredients, how many dozen cookies can he make?

(A) 9 dozen
(B) 12 dozen
(C) 15 dozen
(D) 24 dozen

- 84.** Simplify: $(5x + 1)(3x - 4)$

(A) $15x^2 - 17x - 4$
(B) $-2x - 4$
(C) $8x - 3$
(D) $15x^2 + 23x - 4$

- 85.** Which number equals 7 thousandths?

(A) 0.7
(B) 0.07
(C) 0.007
(D) 7,000

- 86.** A newspaper charges advertisers a total of \$5.50 for the first ten words and \$0.70 for each additional word. What is the cost of a 27-word advert?

(A) \$6.20
(B) \$17.40
(C) \$18.90
(D) \$66.90

Questions 87 and 88 are based on the following information.

A sports enthusiast measures the number of calories used per hour per pound of weight for four different sports. He records the results in the following table.

Sport	Calories Used per Hour per Pound of Weight
Cycling	8.8
Running	12.7
Soccer	9.4
Tennis	6.1

- 87.** What is the average number of calories used per hour per pound of weight for the four sports listed in the table? Give your answer to the nearest one hundredth of a calorie.

- 88.** Which of the following could be used to calculate how many calories a 170-pound man would use by cycling for 20 minutes?

- (A) $\frac{170 \times 8.8}{3}$
 (B) $\frac{170 \times 8.8}{20}$
 (C) $\frac{170 \times 20}{8.8}$
 (D) $\frac{20 \times 8.8}{170}$

Questions 89 through 91 are based on the following information.

A large circular pizza has an 18-inch diameter and is cut into 8 equal slices.

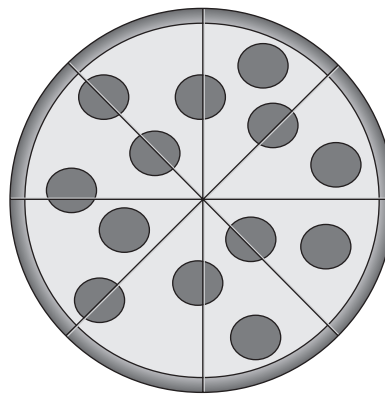

- 89.** What is the innermost angle of one slice of the pizza?

- 90.** What is the perimeter of one slice of the pizza?

- (A) 2.25π
 (B) $2.25\pi + 9$
 (C) $2.25\pi + 18$
 (D) 81π

- 91.** What is the total area of two slices of the pizza?

- (A) 20.25π
 (B) 36π
 (C) 41.5π
 (D) 81π

Questions 92 and 93 are based on the following information.

Jack needs to put a fence around his lawn. The dimensions of the lawn are shown in the following diagram.

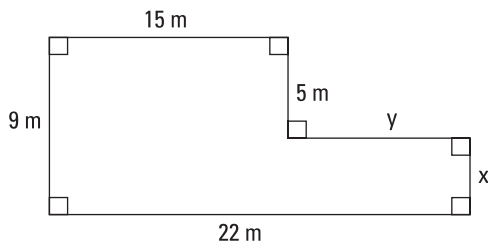

- 92.** Find the values of x and y , respectively.
- (A) $x = 7, y = 4$
 - (B) $x = 4, y = 7$
 - (C) $x = 5, y = 15$
 - (D) $x = 15, y = 5$
- 93.** If lawn fertilizer costs \$0.15 per square meter, how much will it cost Jack to fertilize his lawn? Round your answer to the nearest dollar.
- (A) \$24
 - (B) \$25
 - (C) \$30
 - (D) \$163
- 94.** What is the radius (in cm) of a circle whose circumference happens to equal its area (in cm^2)?
- (A) 2 cm
 - (B) 3 cm
 - (C) 5 cm
 - (D) 10 cm
- 95.** What is the probability of tossing 5 heads in a row when using a fair coin?
- (A) $\frac{1}{2}$
 - (B) $\frac{1}{8}$
 - (C) $\frac{1}{32}$
 - (D) $\frac{5}{2}$
- 96.** The temperature at 5:00 a.m. was -11 degrees. By 8:00 a.m., the temperature is -2 degrees. If the temperature continues to rise at the same rate, what will the temperature be at 2:00 p.m.?
- (A) 7 degrees
 - (B) 16 degrees
 - (C) 21 degrees
 - (D) 27 degrees
- 97.** If sales tax is 6 percent, what would be the tax on a shirt that cost \$68.30? Round your answer to the nearest cent.
- (A) \$4.09
 - (B) \$4.10
 - (C) \$4.58
 - (D) \$4.59
- 98.** The dimensions of a rectangular prism are 9 inches wide by 18 inches long by 2 feet tall. What is the volume of the prism in cubic feet?
- (A) 2.25
 - (B) 8.75
 - (C) 36
 - (D) 324

Questions 99 through 101 are based on the following diagram, which shows a right triangular prism.

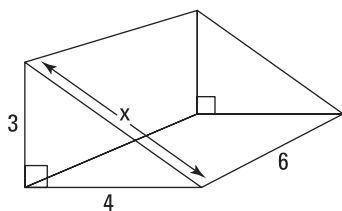

99. What is the length of the hypotenuse of the prism's triangular base?
- _____
100. What is the area of the triangular base of the prism?
- (A) 6
(B) 10
(C) 12
(D) 36
101. What is the volume of the prism?
- (A) 36
(B) 45
(C) 72
(D) 90
102. If $a = -3$ and $b = 2$, what is the value of $\frac{a^2 - 3b}{a} + 4$?
- (A) 3
(B) 9
(C) 15
(D) 21

103. What is the next term in the following geometric sequence?

810, -270, 90, -30, ...

- (A) $\frac{10}{3}$
(B) $-\frac{10}{3}$
(C) 10
(D) -10

Questions 104 through 106 are based on the following information.

The test scores of 10 students are listed in the following frequency table.

Score	Number of Students
72	1
85	3
90	4
100	2

104. What is the average score? (Round your answer to the nearest whole number)
- (A) 35
(B) 81
(C) 87
(D) 89
105. If the lowest two scores are omitted, what is the new average score? (Round your answer to the nearest whole number)
- (A) 73
(B) 89
(C) 91
(D) 92

- 106.** Simplify the expression: $(7x - 5y + 2z) - (2x - y + 3z)$
- (A) $5x - 6y + 5z$
 (B) $5x - 4y + 5z$
 (C) $5x - 4y - z$
 (D) $9x - 4y - z$
- 107.** If your daily commute equals 95 minutes, how long, in hours and minutes, do you spend commuting during a 5-day work week?
- (A) 1 hour, 35 minutes
 (B) 6 hours, 25 minutes
 (C) 7 hours, 55 minutes
 (D) 8 hours, 45 minutes
- 108.** If the base of a triangle is 6 inches and its area is 60 square inches, what is the height of the triangle?
- (A) 5 inches
 (B) 10 inches
 (C) 20 inches
 (D) 180 inches
- 109.** The speed of sound in air is 320 meters per second. If you see a flash of lightning and it takes 8 seconds before you hear the thunder, how many kilometers away was the lightning strike? (Assume that the light reaches you instantly.)
- (A) 2.56 kilometers
 (B) 4 kilometers
 (C) 40 kilometers
 (D) 2560 kilometers
- 110.** What is the slope of the line that passes through the coordinates $(1, -7)$ and $(8, 5)$?
- (A) $-\frac{2}{7}$
 (B) $-\frac{7}{2}$
 (C) $\frac{12}{7}$
 (D) $\frac{7}{12}$

- 111.** On Monday, Andrea finished $\frac{1}{4}$ of her homework assignment. On Tuesday, she completed $\frac{1}{2}$ of the remaining work. What fraction of her assignment does Andrea still have left to complete?

- (A) $\frac{1}{8}$
 (B) $\frac{1}{4}$
 (C) $\frac{3}{8}$
 (D) $\frac{5}{8}$

- 112.** Norman is determining what his gross pay at the end of the week should be. If he gets paid \$13.15 per hour and works 18 hours, what should his gross pay be? (*Note:* You may *not* use a calculator.)
- _____

Questions 113 and 114 are based on set A listed here.

$$A = \{11, 7, 2, 16, 3, 11, 2, 37, 0, 11\}$$

- 113.** Fill in the blanks with the correct values to complete the sentence below:

The mode of set A equals _____, whereas the median of set A equals _____.

- 114.** Find the arithmetic mean (average) of set A.

- (A) 7
 (B) 9
 (C) 10
 (D) 11

- 115.** Simplify $5 \times (91^0 + 3^2)$.

- (A) 35
 (B) 45
 (C) 50
 (D) 500

- 116.** What is the solution to the equation?

$$5(x-2) + x = 2(3-x)$$

- (A) 2
(B) $\frac{8}{7}$
(C) 4
(D) $\frac{7}{16}$
- 117.** Children's tickets to the zoo cost \$9 each, and adult tickets cost \$16 each. On Monday, the zoo sold a total of 95 tickets and made \$1,380 on ticket sales. Which of the following systems of equations could be used to find out how many of each ticket type was sold? Let a equal the number of adult tickets, and let c equal the number of child tickets.
- (A) $a + c = 1,380$, $9c + 16a = 95$
(B) $a + c = 95$, $9a + 16c = 1,380$
(C) $a + c = 95$, $9c + 16a = 1,380$
(D) $a + c = 1,380$, $9a + 16c = 95$
- 118.** Fred's wallet contains coins with a total worth of \$1.45. Suppose he has three times as many dimes as quarters and has exactly 7 nickels and no pennies. How many dimes does he have?
- (A) 2
(B) 3
(C) 6
(D) 9

Questions 119 and 120 are based on the following function.

$$f(x) = 8 - 4x$$

- 119.** What is the value of the function when $x = -1$?
- (A) 4
(B) 8
(C) 12
(D) 24
- 120.** For what value of x does $f(x) = -4$?
- (A) -8
(B) -1
(C) 3
(D) 24
- 121.** The formula for the volume of a cylinder is $V = \pi r^2 h$, where r is the radius of the base and h is the height of the cylinder. Which formula could be used to find h if you're given V and r ?
- (A) $h = \frac{\pi r^2}{V}$
(B) $h = V\pi r^2$
(C) $h = \frac{V}{\pi r^2}$
(D) $h = \frac{r^2}{\pi V}$
- 122.** Three friends are going to the theater. They arrive just in time to get the last 3 seats that are available together in a row. How many different seating arrangements can the friends sit in?

- 123.** On a sunny day, a clock tower casts a shadow that is 50 feet long. At the same time, a nearby 3-foot-tall stick casts a shadow that is 2.5 feet long. What is the height of the clock tower? Round your answer to the nearest foot.

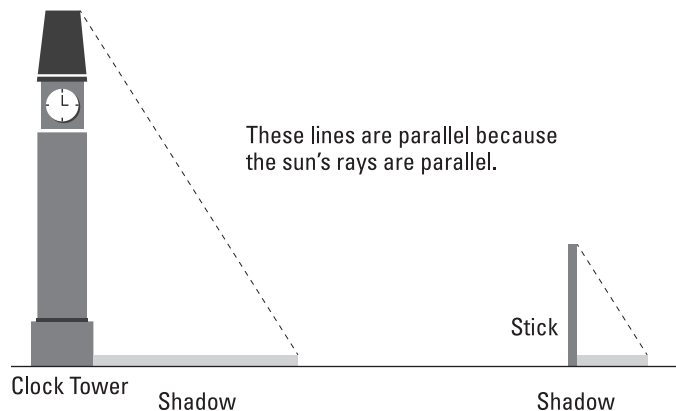

- (A) 24 feet
 (B) 33 feet
 (C) 38 feet
 (D) 60 feet
- 124.** The hypotenuse of a right triangle is 10 inches. If one of the legs of the triangle is 8 inches long, what is the length of the other leg?
 (A) 2 inches
 (B) 6 inches
 (C) $\sqrt{188}$ inches
 (D) 40 inches
- Questions 125 through 127 are based on the following linear equation.*
- $$y = -\frac{3}{7}x - 9$$
- 125.** Which line would be parallel to the given line?
 (A) $y = \frac{3}{7}x + 9$
 (B) $y = -\frac{3}{7}x + \frac{1}{9}$
 (C) $y = -\frac{7}{3}x - 9$
 (D) $y = \frac{7}{3}x - 9$
- 126.** Which line would be perpendicular to the given line?
 (A) $y = \frac{3}{7}x + 9$
 (B) $y = -\frac{3}{7}x + \frac{1}{9}$
 (C) $y = -\frac{7}{3}x - 9$
 (D) $y = \frac{7}{3}x - 9$
- 127.** Which of the following sets of coordinates lies on the given line?
 (A) (0, 9)
 (B) (7, 6)
 (C) (7, -12)
 (D) (14, -9)

- 128.** Lisa and Erica were investigating the relationship of their ages. They figured out that Erica's age is currently 5 less than twice Lisa's age. In addition, the sum of their ages is 73. How old are Erica and Lisa?
- (A) Erica is 47, and Lisa is 26.
(B) Erica is 26, and Lisa is 47.
(C) Erica is 20, and Lisa is 53.
(D) There is not enough information to determine the answer.

Questions 129 and 130 are based on the following information.

A bag contains 6 blue marbles, 5 red marbles, 3 green marbles, and 2 yellow marbles.

- 129.** What fraction of the marbles is blue?
- (A) $\frac{3}{8}$
(B) $\frac{3}{5}$
(C) $\frac{6}{17}$
(D) $\frac{2}{5}$
- 130.** If 2 marbles are removed from the bag one at a time, without being replaced, what is the probability of selecting 2 red marbles in a row?
- (A) $\frac{5}{16}$
(B) $\frac{4}{15}$
(C) $\frac{1}{12}$
(D) $\frac{9}{31}$

- 131.** Soup is sold in both rectangular cardboard cartons and large cylindrical cans. The carton has dimensions of 3 inches by 4 inches by 7 inches and costs \$4.20. The can has a radius of 3 inches and a height of 4 inches and costs \$6.79. Which is a better buy?
- (A) The can is a better value.
(B) The carton is a better value.
(C) Both containers offer the same value.
(D) There is not enough information to determine the answer.

- 132.** Tamara goes for a dental checkup every 6 months and gets her eyesight checked every 8 months. If she visited her dentist and her optician this week, how many months will it be until she visits them both in the same week again?
- _____

- 133.** Meg can swim 4 laps in 11 minutes. How long should she plan to practice if she needs to swim 10 laps, assuming her speed is constant?
- (A) 4.4
(B) 15.7
(C) 22
(D) 27.5

Questions 134 through 136 are based on the following information.

Barney joined a gym to become stronger, and every 4 weeks he notes the maximum amount of weight that he can bench-press. He records his progress over a five-month period in the following table.

Weeks	Weight in Pounds
0	30
4	38
8	46
12	54
16	62
20	70

- 134.** Barney plots the data on a coordinate grid. He begins by plotting the data for Week 4 and Week 16.

What are the coordinates of the two points?

- 135.** Which of the following equations allows Barney to predict the maximum weight he will be able to lift in the future?

- (A) $y = -2x + 3$
 (B) $y = 30x + 2$
 (C) $y = -2x + 30$
 (D) $y = 2x + 30$

- 136.** If Barney's strength continues to grow at the same rate, at what week will he be able to lift 100 pounds?

- (A) Week 25
 (B) Week 30
 (C) Week 35
 (D) Week 50

- 137.** A box has the dimensions shown here:

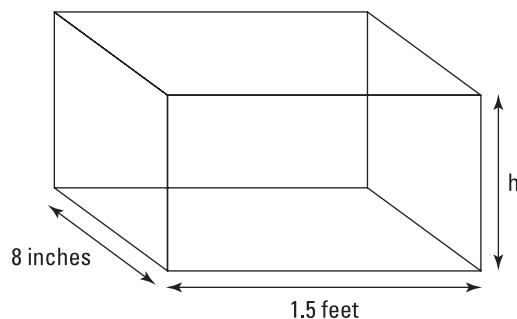

If the volume of the box is 1,368 cubic inches, what is the height of the box? Give your answer to the nearest tenth of an inch.

- (A) 7.5
 (B) 9.5
 (C) 12.0
 (D) 114.0

- 138.** Which of the following graphs shows all the possible numbers represented by the inequality $30 < 15x \leq 90$.

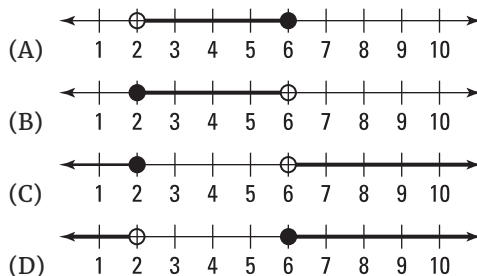

Questions 139 through 141 are based on the following information.

Eleven fishermen entered a fishing competition to catch as many fish as possible in 1 hour. The median number of fish caught for all 11 fishermen was 4, and the modal score was 3.

The number of fish caught for each of the first 10 fishermen is shown in the following graph.

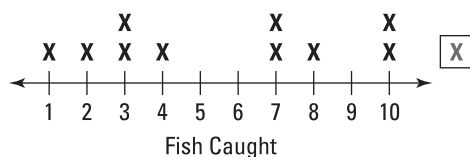

- 139.** What was the average number of fish caught by the first 10 fishermen represented on the line plot?
- (A) 4.5
(B) 5.0
(C) 5.5
(D) 6.5
- 140.** What was the number of fish caught by the 11th fisherman?
- (A) 2
(B) 3
(C) 4
(D) 5
- 141.** What was the range of the number of fish caught by the 11 fishermen?
- _____

Questions 142 and 143 are based on the following information.

The probability that Daryl will pass each of three tests is given in the following table.

Test	Math	English	Chemistry
Probability of passing	50%	60%	80%

- 142.** What is the probability that Daryl will not pass his chemistry test?
- (A) 20%
(B) 40%
(C) 50%
(D) 80%
- 143.** What is the chance that Daryl will pass all three tests?
- _____
- 144.** What is the probability that Daryl will pass two out of the three tests? Round your answer to the nearest whole percentage.
- (A) 30%
(B) 46%
(C) 52%
(D) 190%

- 145.** Using the information in the following table, estimate to the nearest hundred the total number of tickets sold at the movie theater last week. (*Note:* You may not use a calculator.)

Movie	Tickets Sold
<i>The Godmother</i>	721
<i>Moon Wars</i>	391
<i>The Silence of the Goats</i>	813
<i>A Clockwork Lemon</i>	270
<i>Pulp Fake News</i>	602

- (A) 2,600
 (B) 2,800
 (C) 3,000
 (D) 3,100

Questions 146 through 148 are based on the following information.

After Halloween, the average price of a pound of candy drops in a linear fashion over a four-week period, as shown in the following table:

Weeks after Halloween	Price (\$ per Pound)
Week 1	\$5.29
Week 2	\$4.58
Week 3	\$3.87
Week 4	\$3.16

- 146.** What is the range of the prices in the table? Give your answer to the nearest cent.
- _____

- 147.** What is the average price of a pound of candy during the given four-week period? Give your answer to the nearest cent.

- (A) \$3.42
 (B) \$3.43
 (C) \$4.22
 (D) \$4.23

- 148.** If the average price of a pound of candy continues to decrease at the same rate, what will 4 pounds of candy cost six weeks after Halloween?

- (A) \$1.03
 (B) \$1.74
 (C) \$4.12
 (D) \$6.96

Questions 149 and 150 are based on the following information.

$$x = p^3, y = p^{-2}, \text{ and } z = p^2$$

- 149.** Which of the following expresses $(y \cdot z)^x$ in terms of p ?

- (A) p^3
 (B) p^{-12}
 (C) p^{20}
 (D) 1

- 150.** Which of the following expresses $(x)(y)(z)^3$ in terms of p ?

- (A) 0
 (B) p^{-2}
 (C) p^7
 (D) p^9

Questions 151 through 153 are based on the following figure, which shows a picture frame for a photo.

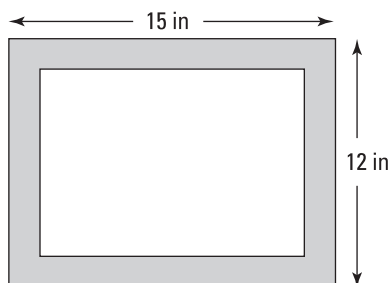

- 151.** What is the perimeter of the rectangular picture frame?
- _____
- 152.** Sammy has a 12-inch by 9-inch photo that he wants to put in the frame. What is the length of the diagonal of the rectangular photo?
- (A) 8
(B) 13
(C) 15
(D) 84
- 153.** Jeff has a different photo that he wants to put in the frame. If the wooden border of the frame (shown by the shaded region in the figure) is x inches wide all the way around, which of the following represents the area A of Jeff's photo (the non-shaded region)?
- (A) $A = (15 - x)(12 - x)$
(B) $A = (15 - 2x)(12 - 2x)$
(C) $A = (15 + 2x)(12 + 2x)$
(D) $A = (15 + x)(12 + x)$

154.

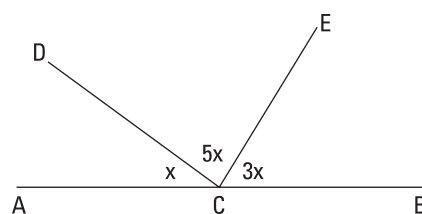

What is the measure of the obtuse angle shown in the figure?

- (A) 20°
(B) 60°
(C) 100°
(D) 140°
- 155.** If 3 out of 8 drivers exceed the speed limit on a given stretch of highway, what is the chance that a speed camera will catch a speeder if it photographs a car at random? Give your answer to the nearest tenth of a percent.
- (A) 30.0%
(B) 37.5%
(C) 42.5%
(D) 45.0%
- 156.** If the base of a triangle is 8 inches and the area of the triangle is 48 square inches, what is the height of the triangle?
- (A) 6 inches
(B) 8 inches
(C) 10 inches
(D) 12 inches
- 157.** Which number equals 2 hundredths?
- (A) 0.2
(B) 0.02
(C) 0.002
(D) 200

- 158.** A limo company charges \$25.50 for the first 8 miles plus an additional \$3.50 for each extra mile. What is the cost of a 13-mile limo ride?
- (A) \$29.00
 (B) \$43.00
 (C) \$45.50
 (D) \$221.50

Questions 159 and 160 are based on the following information.

The following table shows the time needed to cook a turkey based on the weight of the turkey and the temperature of the oven. After the turkey is removed from the oven, it should be left to rest for 30 minutes before it's carved to ensure that it remains juicy.

Weight of Turkey (Pounds)	Cooking Time at 325°F	Cooking Time at 375°F
8–12 lb.	2.5–3.0 hours	2.0–2.5 hours
12–16 lb.	3.0–3.5 hours	2.5–3.0 hours
16–20 lb.	3.5–4.0 hours	3.0–3.5 hours
20–24 lb.	4.0–4.5 hours	3.5–4.0 hours

- 159.** How long does a 23-pound turkey take to cook at an oven temperature of 375°F?
- (A) 2.5–3.0 hours
 (B) 3.0–3.5 hours
 (C) 3.5–4.0 hours
 (D) 4.0–4.5 hours
- 160.** Venus is cooking a Thanksgiving turkey that weighs 16 pounds. Her oven has only two temperature settings: 325°F or 375°F. If she wants to serve a juicy turkey to her family at 2:00 p.m., what is the latest time that she can begin to cook the turkey?
- (A) 10:30 a.m.
 (B) 11:00 a.m.
 (C) 11:30 a.m.
 (D) Noon

- 161.** If $\frac{2}{17}x = 15$, what is $\frac{6}{17}x$? (Note: You may not use a calculator.)
- _____

Questions 162 through 164 are based on the following information.

Jack earned \$30,000 per year for two consecutive years. For each of the next three years, Jack earned \$40,000 per year.

- 162.** Fill in the blanks with the appropriate values to complete the sentence below.
- During the 5-year period, the mode of Jack's salary equaled _____, and the range equaled _____.
- 163.** What was the median value of Jack's salary during the 5-year period?
- (A) \$30,000
 (B) \$35,000
 (C) \$36,000
 (D) \$40,000
- 164.** What was the mean value of Jack's salary during the 5-year period?
- _____

Questions 165 through 167 are based on the following figure.

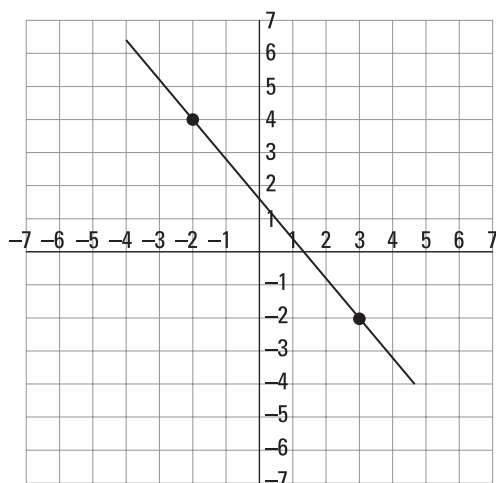

- 165.** What is the slope of the line?
- (A) $-\frac{6}{5}$
 (B) $-\frac{5}{6}$
 (C) $\frac{6}{5}$
 (D) $\frac{5}{6}$
- 166.** What is the length of the line segment joining the two data points shown on the figure?
- (A) $\sqrt{61}$
 (B) $\sqrt{71}$
 (C) 11
 (D) $\sqrt{17}$
- 167.** What is the location of the midpoint of the segment joining the two data points shown in the figure?
- (A) (0,2)
 (B) (1.5, 0)
 (C) (1.0, 0.25)
 (D) (0.5, 1)
- 168.** Anne asks the butcher for $1\frac{3}{4}$ pounds of ham. The butcher places some ham on the digital scale, which reads 1.95. How much ham must the butcher remove to give Anne the amount that she asked for? (Note: You may *not* use a calculator.)
- (A) 0.10 pounds
 (B) 0.20 pounds
 (C) 0.45 pounds
 (D) 0.70 pounds
- 169.** Tom's gross weekly salary is \$840. His salary is taxed at 17%. What is Tom's net salary? Round your answer to the nearest cent.
- (A) \$142.80
 (B) \$672.90
 (C) \$697.20
 (D) \$982.80
- 170.** The dimensions of a fish tank are 1 foot, 6 inches wide by 1 foot, 8 inches tall by 4 feet long. What is the volume of the tank in cubic feet?
- (A) 10
 (B) $11\frac{2}{3}$
 (C) 13
 (D) $14\frac{1}{12}$
- 171.** The distance between two planets is 4,560,000,000 miles. Express this in scientific notation.
- (A) 4.56×10^6
 (B) 4.56×10^7
 (C) 456×10^7
 (D) 4.56×10^9
- 172.** A hiker walks 16 miles due north and then turns and walks 12 miles due west. How many miles is the hiker from his starting point?

- 173.** Jeff currently weighs 214 pounds. He plans to go on a diet and lose 4.5 pounds per month. How many pounds should he weigh after 5 months of dieting? (*Note:* You may *not* use a calculator.)
- (A) 186.4
 (B) 191.5
 (C) 195.5
 (D) 199.5
- 174.** Which of the following lists the solutions to the equation $x^2 - x - 20 = 0$?
- (A) 2 and -10
 (B) -2 and 10
 (C) 4 and -5
 (D) -4 and 5
- 175.** Last season, a soccer team won five times as many games as it lost, with 8 games ending in a draw. If there were 38 games in the season, how many games did the team win?
- (A) 5
 (B) 6
 (C) 24
 (D) 25
- 176.** What is the next term in the following sequence?
- 1, 1, 2, 3, 5, 8, 13, 21, ...
- _____

Questions 177 and 178 are based on the following information.

The speeds of 12 cars (rounded to the nearest 10 miles per hour) were recorded and listed in this frequency table.

Speed in Miles per Hour	Number of Cars
30	2
40	3
50	1
60	6

- 177.** What is the average speed of the 12 cars in miles per hour? Round your answer to the nearest whole number.
- (A) 36
 (B) 45
 (C) 49
 (D) 51
- 178.** By what percent is the fastest recorded speed greater than the slowest recorded speed?
- (A) 30%
 (B) 50%
 (C) 80%
 (D) 100%
- 179.** Simplify the expression:
 $2(7x - 5y) - 3(2x - y)$
- (A) $8x - 7y$
 (B) $8x - 4y$
 (C) $8x - 13y$
 (D) $9x - 6y$
- 180.** If 2 cookies cost y dollars, how many dollars do x cookies cost?
- (A) $2xy$
 (B) $\frac{xy}{2}$
 (C) $\frac{2x}{y}$
 (D) $\frac{2y}{x}$

- 181.** The square root of 73 lies between which two integers? (*Note:* You may not use a calculator.)

(A) 6 and 7
 (B) 7 and 8
 (C) 8 and 9
 (D) 9 and 10

- 182.** If two sides of a triangle are 10.2 and 5.8 inches long, which of the following cannot be the length of the other side?

(A) 4.3 inches
 (B) 5.8 inches
 (C) 11.7 inches
 (D) 15.2 inches

- 183.** What is the value of $|3 - 8| - |8 - 3|$? (*Note:* You may not use a calculator.)

(A) -10
 (B) -5
 (C) 0
 (D) 22

- 184.** Which of the following rectangular metal boxes can hold the most dice if each die has a volume of one cubic inch and the lid of the box fits tightly?

(A) 9 inches x 15 inches x 11 inches
 (B) 20 inches x 7.5 inches x 10 inches
 (C) 12.5 inches x 7.5 inches x 16.5 inches
 (D) 20 inches x 7.5 inches x 10.5 inches

- 185.** In the number line, the vertical marks are equally spaced. What is the value at point A?



Questions 186 and 187 are based on the figure and information below.

A researcher asked a group of 400 students about what types of pets they preferred. She recorded the results in the following pie chart.

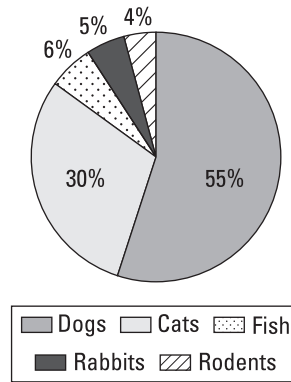

- 186.** What is the ratio of the number of dogs to cats to rabbits that the students prefer? Simplify your answer as much as possible.

(A) 1:6:11
 (B) 5:1:6
 (C) 11:6:1
 (D) 11:5:1

- 187.** How many more students preferred fish than rodents?

- 188.** If $\frac{x}{y} \cdot \frac{y}{z} \cdot \frac{z}{w} \cdot p = 1$, which of the following represents the value of p ?

(A) 1
 (B) $\frac{x}{w}$
 (C) $\frac{w}{x}$
 (D) $\frac{1}{p}$

- 189.** If $w = x$ and $y < z$, which of the following is true for all cases?
- (A) $w + y > x + z$
 (B) $wy < xz$
 (C) $w - y > x - z$
 (D) $w - x < y - z$

- 190.** Regular tickets to a concert cost \$25 each, and VIP tickets cost \$45 each. The concert hall sold a total of 270 tickets and made \$7,650 on ticket sales.

The number of VIP tickets sold was _____, and the number of regular tickets sold was _____.

- 191.** The product of the first six prime numbers is divisible by which of the following?
- (A) 16
 (B) 18
 (C) 22
 (D) 24

Questions 192 and 193 are based on the following function.

$$f(x) = x^2 - 4x$$

- 192.** What is the value of the function when $x = -4$?
- (A) -8
 (B) 0
 (C) 16
 (D) 32
- 193.** For what value of x does $f(x) = 12$?
- (A) 96
 (B) 2 and -6
 (C) 6 and -2
 (D) 0 and 6

- 194.** Simplify the following expression:
 $3^4 + 3^4 + 3^4$
- (A) 3^5
 (B) 9^{12}
 (C) 3^{12}
 (D) 3^{64}

- 195.**

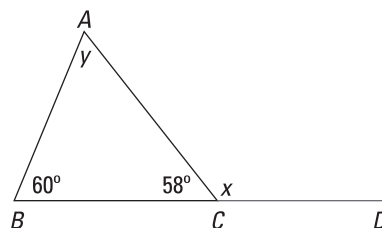

In this triangle, angle x equals _____ and angle y equals _____.

- 196.** A cube with 3-inch sides is painted blue and then cut into 27 smaller cubes with 1-inch sides. How many of the new smaller cubes have exactly two faces that are painted blue?

- 197.** The lengths of the legs of a right triangle are 4 inches and 5 inches, respectively. What is the length of the hypotenuse?
- (A) 3 inches
 (B) 9 inches
 (C) $\sqrt{41}$ inches
 (D) 41 inches

Questions 198 through 200 are based on the following linear equation.

$$y = -6x - 9$$

- 198.** Which line would be parallel to the given line?
- (A) $y = -\frac{1}{6}x + 9$
 (B) $y = \frac{1}{6}x + \frac{1}{9}$
 (C) $y = -6x - 1$
 (D) $y = 6x + 9$

199. Which line would be perpendicular to the given line?

- (A) $y = -\frac{1}{6}x + 9$
(B) $y = \frac{1}{6}x + \frac{1}{9}$
(C) $y = -6x - 1$
(D) $y = 6x + 9$

200. What are the coordinates of the point of intersection of the given line with the line $y = -3x + 18$?

- (A) (0, -9)
(B) (3, 9)
(C) (-9, 45)
(D) (-9, -27)

201. Two years ago, Sammy was 5 years younger than Michael is today. If Michael is currently M years old, how old will Sammy be 10 years from now?

- (A) $M - 5$
(B) $M + 2$
(C) $M + 7$
(D) $M + 10$

202. $3\frac{1}{10} + 1\frac{11}{100} + 2\frac{111}{1,000} =$

(Note: You may not use a calculator.)

- (A) 6.111
(B) 6.123
(C) 6.321
(D) 6.1111

203. Mr. Burke's class has twice as many girls as boys. If half of the boys and a quarter of the girls are in the chess club, what is the ratio of girls to boys who are in the chess club?

- (A) 4:1
(B) 2:1
(C) 1:1
(D) 1:2

204. Beans are sold in small or large cylindrical cans. The small can has a diameter of 4 inches and a height of 10 inches and costs \$3.50. The big can has a diameter of 8 inches and a height of 5 inches and costs \$6.50. Which is a better buy?

- (A) The small can
(B) The large can
(C) Both have the same value
(D) Not enough information

205. Two lighthouses flash their lights every 21 seconds and 77 seconds, respectively. If both lighthouses are switched on at the same time so their lights begin by flashing simultaneously, after how many seconds will both lights first flash in synch again?

206. This trapezoid has an area of 38 square feet. What is the length of the unknown base of the trapezoid in feet?

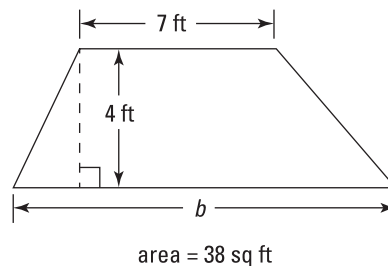

- (A) 4
(B) 7
(C) 8
(D) 12

Questions 207 and 208 are based on the following figure.

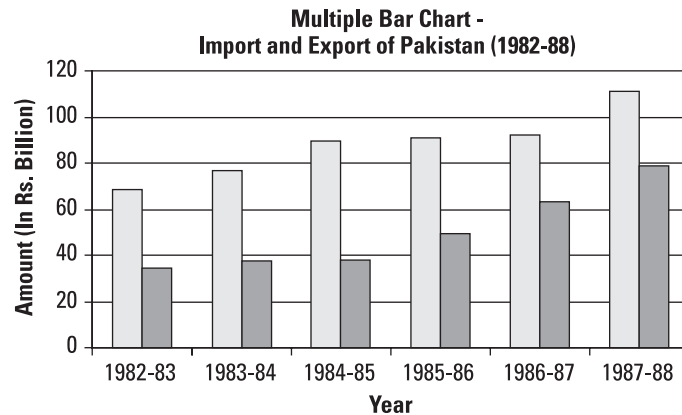

This chart represents the imports and exports of Pakistan during the period 1982–1988 in billions of Pakistani rupees (Rs.). The darker bars represent imports, and the lighter bars are exports.

- 207.** In which year did the value of exports exceed the value of imports by the greatest amount?
- (A) 1982–1983
(B) 1983–1984
(C) 1984–1985
(D) 1987–1988
- 208.** What was the average approximate value of the exports (in Rs.) for the six years shown in the chart?
- (A) 48 billion
(B) 62 billion
(C) 75 billion
(D) 88 billion
- 209.** What was the average annual increase for imports (in Rs.) for the six years shown in the chart?
- (A) 7 billion
(B) 8.4 billion
(C) 11 billion
(D) 42 billion
- 210.** Two square rugs have a combined area of 20 square meters. If the area of the large rug is four times as large as the area of the small rug, what is the perimeter of the smaller rug?
- (A) 2 meters
(B) 4 meters
(C) 8 meters
(D) 16 meters
- 211.** Forty percent of the students in Dr. Donnelly’s math class received a grade of A. If 10 students received an A, how many students are in Dr. Donnelly’s math class?
- (A) 4 students
(B) 14 students
(C) 22 students
(D) 25 students
- 212.** What is the acute angle between the hands of a clock when it is exactly 10 p.m.?
- (A) 30°
(B) 45°
(C) 60°
(D) 75°

213. What is the missing value in the following table?

x	$f(x)$
-2	-10
0	-4
2	2
4	?
6	14

214. Janice's car averages 32 miles per gallon (mpg) and holds approximately 13 gallons of gas. If she is driving from Boston to Arizona and the distance between the two locations is 2,220 miles, how many tanks of gas will she need?
- (A) 4 tanks
 (B) 5 tanks
 (C) 6 tanks
 (D) 7 tanks
215. Which of the following is equivalent to 45%?
- (A) 4.5
 (B) 0.045
 (C) $\frac{9}{10}$
 (D) $\frac{9}{20}$

216. Find the value of x in the figure.

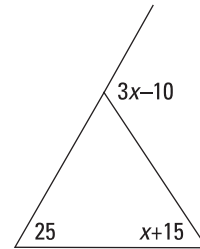

- (A) 25
 (B) 40
 (C) 65
 (D) 115
217. Simplify $3\sqrt{5x^6} + 6\sqrt{5x^6}$ completely.
- (A) $9\sqrt{10x^{12}}$
 (B) $9x^2\sqrt{10}$
 (C) $9\sqrt{10x^6}$
 (D) $9x^3\sqrt{5}$
218. Which of the following is listed in ascending order?
- (A) $\frac{1}{3}$, 0.3, $1\frac{2}{5}$, 250%
 (B) $\frac{1}{3}$, 250%, 0.3, $1\frac{2}{5}$
 (C) 0.3, $\frac{1}{3}$, $1\frac{2}{5}$, 250%
 (D) $\frac{1}{3}$, 0.3, $1\frac{2}{5}$, 250%
219. Emily's garden has the same value for its perimeter and its area. Which of the following could be the shape and dimensions of her garden? (Note: You may not use a calculator.)
- (A) rectangle; 2 ft \times 8 ft
 (B) square; 5 ft \times 5 ft
 (C) circle; radius = 2 ft
 (D) right triangle; 3 ft \times 4 ft \times 5 ft

220. Ryan works at a coffee shop that sells an average of 107 cups of coffee an hour. If one pot of coffee fills 10 cups, how many pots of coffee will the shop go through on an average day if the shop opens at 7:00 a.m. and closes at 4:00 p.m.?

- (A) 96
- (B) 97
- (C) 963
- (D) 1,070

221. Cory likes to ride his hoverboard and can travel at a speed of 11 miles per hour. How fast does Cory go in feet per minute?

222. Which of the following is equivalent to 3,888?

- (A) $5^2 2^5$
- (B) $2^3 3^5$
- (C) $3^4 5^3$
- (D) $2^4 3^5$

223. The surface area of a cube equals 150 in.². What is its volume in cubic inches?

- (A) 5
- (B) 100
- (C) 125
- (D) 150

224. If $x = p^5$, $y = p^{-4}$, and $z = p$, simplify the following expression, leaving your answer in terms of p .

$$\left(\frac{x \cdot y}{z}\right)^5$$

- (A) 0
- (B) p^{-50}
- (C) p^{-20}
- (D) 1

225. In a triangle, the sides have a ratio of 3 : 7 : 10. If the perimeter is 210 feet, what is the length of the longest side in feet?

- (A) 10.5
- (B) 31.5
- (C) 73.5
- (D) 105

226. If x is a positive integer and $f(x) = \frac{14+x}{2+x}$, then

- (A) $f(x) \leq 5$
- (B) $f(x) = 5$
- (C) $f(x) > 5$
- (D) $f(x)$ is sometimes less than 5 and sometimes greater than 5, depending upon the value of x .

Questions 227 and 228 are based on the following image, which shows a rectangle with a semicircular top.

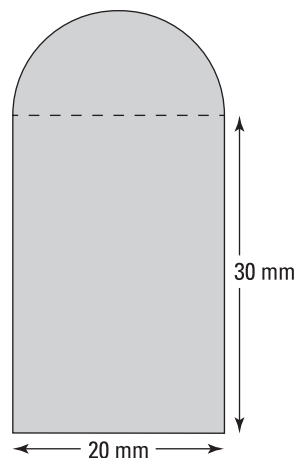

227. What is the perimeter of the shape?

- (A) $50 + 20\pi$
- (B) $50\pi + 600$
- (C) $80 + 10\pi$
- (D) $80 + 20\pi$

- 228.** What is the area of the shape?
- (A) $20\pi + 600$
 (B) $50\pi + 600$
 (C) $200\pi + 600$
 (D) $400\pi + 600$
- 229.** Harry rents a power drill from 8:30 p.m. until 3:30 p.m. on the same day. He paid a total of \$25.06. What was the hourly rental fee, rounded to the nearest penny? (Note: You may not use a calculator.)
- (A) \$3.13
 (B) \$3.58
 (C) \$2.23
 (D) \$2.51
- 230.** What is the value of $\frac{x^2 - 6x + 9}{x^2 - 6x}$ when $x = -3$?
- (A) 2
 (B) 9
 (C) $\frac{4}{3}$
 (D) $\frac{2}{3}$
- 231.** Sammy earns a weekly base salary of \$750 as a shoe salesman. He also earns a 6% commission on his monthly sales after the first \$1,000. What is his total salary this month if he sells \$4,500 worth of shoes?
- (A) \$210
 (B) \$270
 (C) \$960
 (D) \$1,020
- 232.** Solve the following. You may use numbers, symbols, and/or text in your answer.

$$\sqrt{64} + \sqrt{36}$$

Simplify the expression completely.

- 233.** In scientific notation, what would the number 0.0408 be?
- (A) 4.08×10^2
 (B) 408×10^4
 (C) 40.8×10^{-3}
 (D) 4.08×10^{-2}
- 234.** Jackson is planning his office's annual party, and he has a maximum budget of \$2,825 to spend. He intends to rent a party room that costs \$375 per hour from 8:00 p.m. until 11:00 p.m. He expects a total of 250 people to attend the party and plans to provide each person with a bag of party favors. What is the maximum average amount that Jackson can spend on party favors for each person?

Questions 235 through 237 are based on the following information.

A plane has a seating capacity of 160 passengers, 40 in first class and the rest in economy class. The average first-class ticket costs \$1,200, and the average ticket in economy class is \$400.

- 235.** How much revenue does the airline gross if the plane is full?
- _____
- 236.** If all the first-class tickets are sold but only half of the economy tickets are sold, what is the ratio of the total revenue from the first-class passengers to that of the economy-class passengers?
- (A) 1:1
 (B) 3:1
 (C) 2:1
 (D) 1:3

- 237.** The price of each first-class ticket used to be \$1,500. What percent decrease does the current price represent?
- (A) 20%
 (B) 25%
 (C) 75%
 (D) 80%

Questions 238 and 239 are based on the following information.

The details of Janet's paycheck are shown here.

Salary Details	Amount in Dollars
Gross salary	\$1,012
Federal taxes	\$234
State taxes	\$128
Social Security	\$27

- 238.** What is Janet's take-home (net) salary?
 (Note: You may not use a calculator.)
- _____
- 239.** What percentage of her gross salary does Janet pay toward Social Security? Round your answer to the nearest tenth of a percent.
- (A) 0.03%
 (B) 2.7%
 (C) 0.3%
 (D) 26.7%

Questions 240 and 241 are based on the following figure.

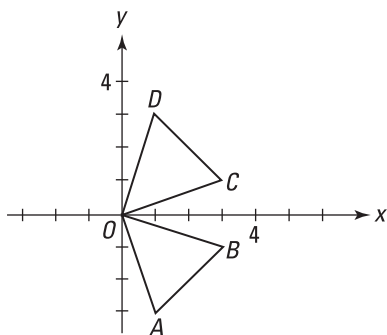

- 240.** What transformation maps triangle ODC onto triangle OBA ?
- (A) Reflection in the y -axis
 (B) Reflection in the line $y = x$
 (C) Rotation 90° clockwise about the origin
 (D) Translation

- 241.** Which of the following line segments has a slope of -1 ?
- (A) \overline{OA}
 (B) \overline{OB}
 (C) \overline{AB}
 (D) \overline{DC}

- 242.** If $x^3 = y^{12}$, what is x in terms of y ?
- (A) y^{-9}
 (B) y^4
 (C) y^9
 (D) y^{36}

Questions 243 through 245 are based on the following information.

Rachel, Brooke, and Steve love reading novels. The graph shows the number of books that each of them read last year.

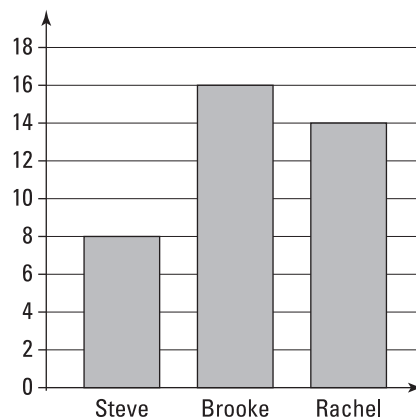

243. What is the ratio of the number of books Brooke read to those Rachel read?

- (A) 2:1
- (B) 16:13
- (C) 8:7
- (D) 7:8

244. If Steve wants to read the same number of books that Rachel read, by what percentage would he need to increase his current number of books read?

- (A) 6%
- (B) 75%
- (C) 100%
- (D) 175%

245. Based on the graph, which of the following statements must be true?

- (A) Brooke can read more words per minute than either Steve or Rachel.
- (B) Steve read only half the number of books that Rachel read.
- (C) Brooke read 100% more books than Steve read.
- (D) The total number of books read equals 40.

246. Which of the following represents the inequality?

$$2 \leq x + 5 < 6$$

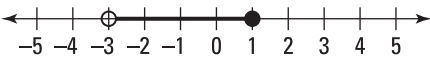
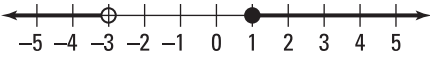
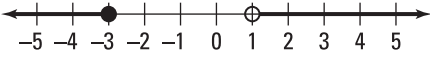
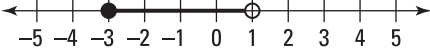
- (A) 
- (B) 
- (C) 
- (D) 

247. If these two boxes have the same volume, what is the height of the second box?

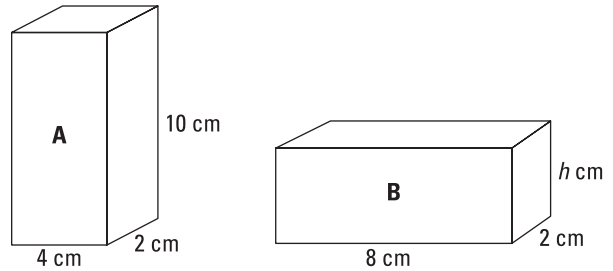

- (A) 4
- (B) 5
- (C) 8
- (D) 10

248. Which of the following numbers has the most unique prime factors?

- (A) 15
- (B) 19
- (C) 27
- (D) 31

249. The following figure shows a piece of paper that is 15 inches long. Peter folds it in half (along the dotted line) and then makes one cut so that when he unfolds the paper, a perfect circle has been cut out. If the circle's diameter equals one-third of the length of the paper, what was the length of the cut that Peter made?

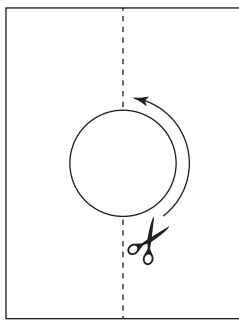

- (A) 2.5π
 (B) 5π
 (C) 10π
 (D) 25π
250. Four frogs were entered in the annual charity High-Hop Contest. The highest jump of each frog is recorded in the table.

Frog	Jump Height (Inches)
Mrs. Croak	$5\frac{4}{5}$
Kermit	$5\frac{3}{8}$
Mr. Hopswell	$5\frac{11}{20}$
Froggy McFrogface	$5\frac{7}{10}$

Which frog hopped the highest? (*Note:* You may *not* use a calculator.)

- (A) Mrs. Croak
 (B) Kermit
 (C) Mr. Hopswell
 (D) Froggy McFrogface

251. This irregular polygon has sides of unequal lengths. If the polygon has a perimeter equal to 52 inches, what is the value of x ?

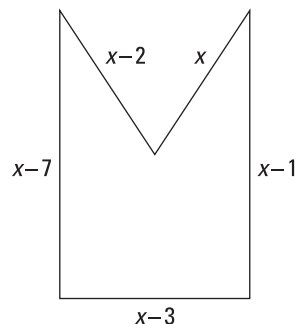

- (A) 3
 (B) 5
 (C) 10
 (D) 13
252. The top four runners to finish a 100-meter race had the following times.

Runner	Time (Seconds)
Tom	10.9192
Kenneth	11.0021
Rupert	10.9289
Usain	10.9191

Based on the above information, which of the following is a true statement?

- (A) Tom was the slowest runner, and Usain was the fastest.
 (B) Kenneth was the slowest runner, and Usain was the fastest.
 (C) Rupert was the slowest runner, and Tom was the fastest.
 (D) Usain was the slowest runner, and Kenneth was the fastest.

Questions 253 and 254 are based on the following information.

Ian has a die that has six sides, each marked with a different integer from 1 to 6. It's a fair die, meaning that each side is equally likely to land face up when the die is rolled. He also has a coin with equal chances of landing on heads or tails.

- 253.** If Ian rolls the die and tosses the coin, what is the probability that he will get a 6 and tails?
- (A) $\frac{2}{3}$
(B) $\frac{1}{8}$
(C) $\frac{1}{12}$
(D) $6\frac{1}{2}$
- 254.** Suppose Ian rolled the die ten times and got ten consecutive 6s. What is the probability of rolling a 6 on the next roll?
- (A) Less than $\frac{1}{6}$
(B) More than $\frac{1}{6}$
(C) $\frac{1}{6}$
(D) Impossible to predict
- 255.** When an unbalanced force is applied to a body, the acceleration of the body is inversely proportional to its mass. If a force applied to a 5 kg body gives it an acceleration of 6 m/s^2 , what acceleration would the same force produce when applied to a 15 kg body?
- (A) 1 m/s^2
(B) 2 m/s^2
(C) 12 m/s^2
(D) 18 m/s^2
- 256.** The scale on Blackbeard's treasure map is 2 inches = 15 feet. According to the map, the treasure is buried 13 inches away from the old hanging tree. If Blackbeard is currently standing under the tree, how many feet away from the treasure is he? (*Note:* You may *not* use a calculator.)
- (A) 26 feet
(B) 30 feet
(C) 97.5 feet
(D) 195 feet
- 257.** A rental car company charges a daily fee of \$50 plus \$0.50 for every mile traveled. Jane rents a car and returns it after three days. If her total charge (not including tax) equals \$225.50, how many miles did she drive?
- (A) 15.1 miles
(B) 151 miles
(C) 351 miles
(D) 451 miles
- 258.** Amy invested \$500 in a savings account that pays a fixed simple interest rate. After three years, her account balance is \$552.50. What percent annual interest did her bank pay?
- (A) 3.5%
(B) 5.5%
(C) 10.5%
(D) 17.5%
- 259.** If $\frac{2}{11}x = 50$, what does $\frac{6}{11}x$ equal? (*Note:* You may *not* use a calculator.)
- (A) 25
(B) 150
(C) 275
(D) 1,100

Questions 260 through 262 are based on the following graph.

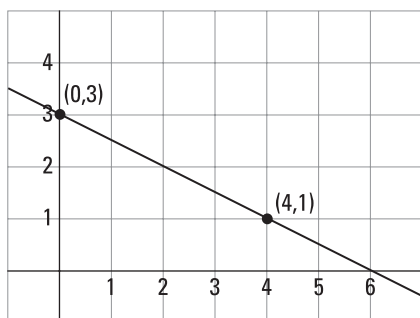

- 260.** What are the coordinates of the midpoint of the two points marked on the graph?
- (A) (6, 0)
 (B) (2, 2)
 (C) (0, 3)
 (D) (3, 1.5)
- 261.** What is the slope of the line?
- (A) -2
 (B) 2
 (C) $-\frac{1}{2}$
 (D) $\frac{1}{2}$
- 262.** What is the equation of the line?
- (A) $y = \frac{1}{2}x + 3$
 (B) $y = 3x - \frac{1}{2}$
 (C) $y = -\frac{1}{2}x + 3$
 (D) $y = +3x + \frac{1}{2}$
- 263.** A clothing store has a 20% off sale. If the sale price of a sweater is \$64, what was the original price of the sweater?
- (A) \$64
 (B) \$76.80
 (C) \$80
 (D) \$96

- 264.** The figure shows two similar triangles: the smaller triangle has a base length of 8 feet and a height of 5 feet (the height of the boy), whereas the second triangle has a base length of 24 feet and a height equal to that of the tree.

How tall is the tree?

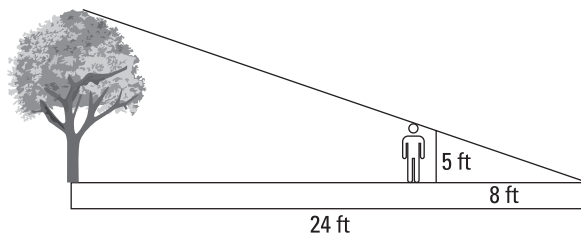

- (A) 15 feet
 (B) 27 feet
 (C) 38.4 feet
 (D) 45 feet
- 265.** An isosceles triangle has an obtuse angle equal to 110° . What is the value of each of the other two angles?
- (A) 25°
 (B) 35°
 (C) 45°
 (D) 70°

Questions 266 through 268 are based on the following graph.

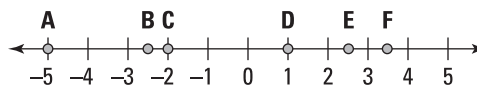

- 266.** What is the value of E minus A?
- (A) -7.5
 (B) -2.5
 (C) 2.5
 (D) 7.5

267. What is the product of A times B times C ?

- (A) -25
- (B) -0.5
- (C) 0
- (D) 25

268. Which of the following is true?

- (A) $|A| < |C|$
- (B) $|D| > |E|$
- (C) $-|E| < A$
- (D) $-A < |B| + |F|$

269. Which of the following shows the correct factorization of the quadratic equation $x^2 - 2x - 24 = 0$?

- (A) $(x - 4)(x + 6) = 0$
- (B) $(x + 4)(x - 6) = 0$
- (C) $(x + 2)(x - 12) = 0$
- (D) $(x + 3)(x - 8) = 0$

270. $(x - y)^2$ is equivalent to which of the following?

- (A) $x^2 - y^2$
- (B) $-x^2y^2$
- (C) $x^2 + y^2 - 2xy$
- (D) $x^2 - y^2 - 2xy$

271. A can of beans has a circular base whose area is 16π square inches. If the height of the can is 8 inches, what is the area of the label that covers the entire side of the can? (Assume the label fits the can perfectly with no overlap.)

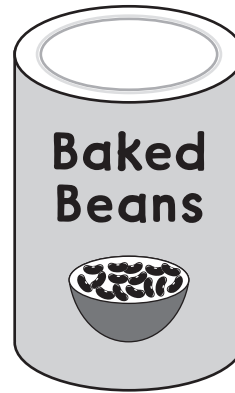

- (A) 16
- (B) 32π
- (C) 64
- (D) 64π

Questions 272 through 274 are based on the following information.

Every year, starting on his 10th birthday, Jacob measured the height of a bush in his garden. The results for 5 years are listed in the table.

Age	Height (in inches)
10	52
11	55
12	58
13	61
14	64

- 272.** Based on the results shown in the table, which of the following is true?
- (A) The median value is 8 inches, and the range is 58 inches.
- (B) The median value is 58 inches, and the range is 12 inches.
- (C) The median value is 48 inches, and the range is 12 inches.
- (D) The median value is 38 inches, and the range is 8 inches.
- 273.** What was the bush's average height during the five-year period?
- (A) 56 inches
- (B) 57 inches
- (C) 58 inches
- (D) 59 inches
- 274.** If Jacob's bush continues to grow at the same rate, how tall will the bush be when Jacob is 17 years old?
- (A) 5 feet, 9 inches
- (B) 5 feet, 11 inches
- (C) 6 feet, 1 inch
- (D) 6 feet, 3 inches
- 275.** A company manufactures widgets. If 3 out of every 50 widgets produced by the company are found to be defective, how many defective widgets will there be in a batch of 2,050 widgets?
- (A) 14
- (B) 41
- (C) 123
- (D) 246

Questions 276 and 277 are based on this figure of a donut:

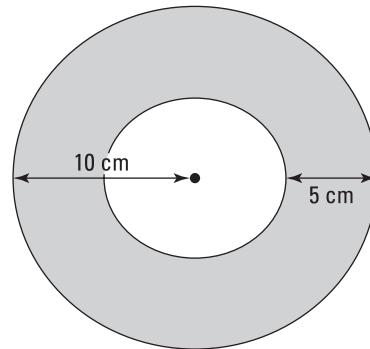

- 276.** What is the outer circumference of the donut?
- (A) 10
- (B) 10π
- (C) 20π
- (D) 100π
- 277.** What is the ratio of the area of the donut (the shaded area) to the area of the hole?
- (A) 1:1
- (B) 2:1
- (C) 1:3
- (D) 3:1
- 278.** How many square yards of carpet would it take to completely cover a rectangular floor that has dimensions of 12 feet wide by 21 feet long?
- (A) 28
- (B) 74
- (C) 84
- (D) 252

- 279.** What is the maximum safe weight w for a person entering a crowded elevator if $\frac{3,412+w}{11} \leq 330$?

- 280.** In scientific notation, what would the number 0.00502 be? (*Note:* You may not use a calculator.)
- (A) 50.2×10^{-4}
 (B) 5.02×10^{-3}
 (C) 5.02
 (D) 5.02×10^3

Questions 281 through 283 are based on this graph.

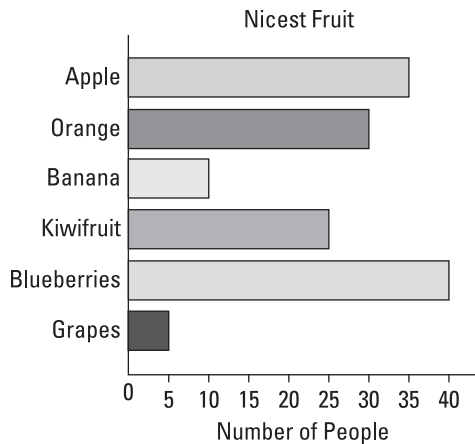

- 281.** Fill in the blanks to complete the sentence.

The most popular fruit is _____, whereas the least popular fruit is _____.

- 282.** How many more people prefer oranges than bananas?

- (A) 5
 (B) 12
 (C) 18
 (D) 30

- 283.** What is the ratio of the number of people who prefer apples to those who prefer oranges?

- (A) 5:4
 (B) 4:5
 (C) 6:7
 (D) 7:6

- 284.** What is the decimal equivalent to $\frac{5}{16}$? (*Note:* You may not use a calculator.)

- 285.** If $f(x) = 15 - 2x$, for what value of x does $f(x) = x$?

- (A) -2
 (B) 0
 (C) 5
 (D) 7.5