

Chapter One

LINEAR FUNCTIONS AND CHANGE

Contents

1.1 Functions and Function Notation	2
Words, Tables, Graphs, and Formulas	2
Mathematical Models	3
Function Notation	4
Functions Not Defined by Formulas	4
When Is a Relationship Not a Function?	5
Vertical Line Test	5
1.2 Rate of Change	10
Rate of Change of a Function	11
Increasing and Decreasing Functions	11
Function Notation for Average Rate of Change	13
1.3 Linear Functions	18
Constant Rate of Change	18
General Formula for Linear Family	20
Tables for Linear Functions	21
1.4 Formulas for Linear Functions	27
From a Table	27
From a Graph	29
From a Verbal Description	30
Alternative Forms for the Equation of a Line	31
Equations of Horizontal and Vertical Lines	32
Slopes of Parallel and Perpendicular Lines	32
Justification of Perpendicular Slopes	33
1.5 Modeling with Linear Functions	37
Interpreting the Parameters of a Linear Function	37
The Effect of Parameters on the Graph	38
Intersection of Two Lines	39
Linear Inequalities in Two Variables	41
1.6 Fitting Linear Functions to Data	46
Laboratory Data: The Viscosity of Motor Oil	46
Interpolation and Extrapolation	47
How Regression Works	48
Correlation	49
REVIEW PROBLEMS	52
STRENGTHEN YOUR UNDERSTANDING	60
Skills Refresher: Linear Equations and the Coordinate Plane	62
Skills for Linear Equations	62
Solving Linear Equations	62
Solving Exactly Versus Solving Approximately	63
Solving Linear Inequalities	63
Systems of Linear Equations	64
Intersection of Two Lines	65

1.1 FUNCTIONS AND FUNCTION NOTATION

In everyday language, the word *function* expresses the notion of dependence. For example, a person might say that election results are a function of the economy, meaning that the winner of an election is determined by how the economy is doing. Someone else might claim that car sales are a function of the weather, meaning that the number of cars sold on a given day is affected by the weather.

In mathematics, the meaning of the word *function* is more precise, but the basic idea is the same. A function is a relationship between two quantities. If the value of the first quantity determines exactly one value of the second quantity, we say the second quantity is a function of the first. We make the following definition:

A **function** is a rule that takes certain numbers as inputs and assigns to each input number exactly one output number. The output is a function of the input.

The inputs and outputs are also called *variables*.

Representing Functions: Words, Tables, Graphs, and Formulas

A function can be described using words, data in a table, points on a graph, or a formula.

Example 1

It is a surprising biological fact that most crickets chirp at a rate that increases as the temperature increases. For the snowy tree cricket (*Oecanthus fultoni*), the relationship between temperature and chirp rate is so reliable that this type of cricket is called the thermometer cricket. We can estimate the temperature (in degrees Fahrenheit) by counting the number of times a snowy tree cricket chirps in 15 seconds and adding 40. For instance, if we count 20 chirps in 15 seconds, then a good estimate of the temperature is $20 + 40 = 60^\circ\text{F}$.¹

The rule used to find the temperature T (in $^\circ\text{F}$) from the chirp rate R (in chirps per minute) is an example of a function. The input is chirp rate and the output is temperature. Describe this function using words, a table, a graph, and a formula.

Solution

- **Words:** To estimate the temperature, we count the number of chirps in fifteen seconds and add forty. Alternatively, we can count R chirps per minute, divide R by four and add forty. This is because there are one-fourth as many chirps in fifteen seconds as there are in sixty seconds. For instance, 80 chirps per minute works out to $\frac{1}{4} \cdot 80 = 20$ chirps every 15 seconds, giving an estimated temperature of $20 + 40 = 60^\circ\text{F}$.
- **Table:** Table 1.1 gives the estimated temperature, T , as a function of R , the number of chirps per minute. Notice the pattern in Table 1.1: each time the chirp rate, R , goes up by 20 chirps per minute, the temperature, T , goes up by 5°F .

Table 1.1 Chirp rate and temperature

R , chirp rate (chirps/minute)	T , predicted temperature ($^\circ\text{F}$)
20	45
40	50
60	55
80	60
100	65
120	70
140	75
160	80

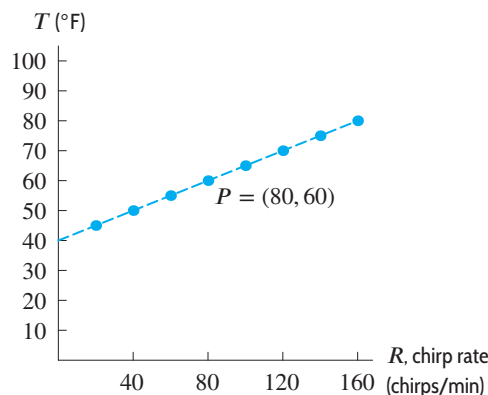

Figure 1.1: Chirp rate and temperature

¹This relationship is often called Dolbear's Law, as it was first proposed in Amos Dolbear, "The Cricket as a Thermometer," in *The American Naturalist*, 31(1897), pp. 970–971.

- **Graph:** The data from Table 1.1 are plotted in Figure 1.1. For instance, the pair of values $R = 80$, $T = 60$ is plotted as the point P , which is 80 units along the horizontal axis and 60 units up the vertical axis. Data represented in this way are said to be plotted on the *Cartesian plane*. The precise position of P is shown by its coordinates, written $P = (80, 60)$.
- **Formula:** A formula is an equation giving T in terms of R . Dividing the chirp rate by four and adding forty gives the estimated temperature, so:

$$\underbrace{\text{Estimated temperature (in } ^\circ\text{F)}}_T = \frac{1}{4} \cdot \underbrace{\text{Chirp rate (in chirps/min)}}_R + 40.$$

Rewriting this using the variables T and R gives the formula:

$$T = \frac{1}{4}R + 40.$$

Let's check the formula. Substituting $R = 80$, we have

$$T = \frac{1}{4} \cdot 80 + 40 = 60,$$

which agrees with point $P = (80, 60)$ in Figure 1.1. The formula $T = \frac{1}{4}R + 40$ also tells us that if $R = 0$, then $T = 40$. Thus, the dashed line in Figure 1.1 crosses (or intersects) the T -axis at $T = 40$; we say the T -*intercept* is 40.

All the descriptions given in Example 1 provide the same information, but each description has a different emphasis. A relationship between variables is often given in words, as at the beginning of Example 1. Table 1.1 is useful because it shows the predicted temperature for various chirp rates. Figure 1.1 is more suggestive of a trend than the table, although it is harder to read exact values of the function. For example, you might have noticed that every point in Figure 1.1 falls on a straight line that slopes up from left to right. In general, a graph can reveal a pattern that might otherwise go unnoticed. Finally, the formula has the advantage of being both compact and precise. However, this compactness can also be a disadvantage since it may be harder to gain as much insight from a formula as from a table or a graph.

Mathematical Models

When we use a function to describe an actual situation, the function is referred to as a **mathematical model**. The formula $T = \frac{1}{4}R + 40$ is a mathematical model of the relationship between the temperature and the cricket's chirp rate. Such models can be powerful tools for understanding phenomena and making predictions. For example, this model predicts that when the chirp rate is 80 chirps per minute, the temperature is 60°F. In addition, since $T = 40$ when $R = 0$, the model predicts that the chirp rate is 0 at 40°F. Whether the model's predictions are accurate for chirp rates down to 0 and temperatures as low as 40°F is a question that mathematics alone cannot answer; an understanding of the biology of crickets is needed. However, we can safely say that the model does not apply for temperatures below 40°F, because the chirp rate would then be negative. For the range of chirp rates and temperatures in Table 1.1, the model is remarkably accurate.

In everyday language, saying that T is a function of R suggests that making the cricket chirp faster would somehow make the temperature change. Clearly, the cricket's chirping does not cause the temperature to be what it is. In mathematics, saying that the temperature "depends" on the chirp rate means only that knowing the chirp rate is sufficient to tell us the temperature.

Function Notation

To indicate that a quantity Q is a function of a quantity t , we abbreviate

Q is a function of t to Q equals “ f of t ”

and, using function notation, to

$$Q = f(t).$$

Thus, applying the rule f to the input value, t , gives the output value, $f(t)$, which is a value of Q . Here Q is called the *dependent variable* and t is called the *independent variable*. In other words,

$$\text{Output} = f(\text{Input})$$

or

$$\text{Dependent} = f(\text{Independent}).$$

We could have used any letter, not just f , to represent the rule.

The expressions “ Q depends on t ” or “ Q is a function of t ” do *not* imply a cause-and-effect relationship, as the snowy tree cricket example illustrates.

Example 2 Example 1 gives the following formula for estimating air temperature, T , based on the chirp rate, R , of the snowy tree cricket:

$$T = \frac{1}{4}R + 40.$$

In this formula, T depends on R . Writing $T = f(R)$ indicates that the relationship is a function.

Example 3 The number of gallons of paint needed to paint a house depends on the size of the house. A gallon of paint typically covers 250 square feet. Thus, the number of gallons of paint, n , is a function of the area to be painted, A ft². We write $n = f(A)$.

- Find a formula for f .
- Explain in words what the statement $f(10,000) = 40$ tells us about painting houses.

Solution (a) If $A = 250$, the house requires one gallon of paint. If $A = 500$, it requires $500/250 = 2$ gallons of paint, if $A = 750$ it requires $750/250 = 3$ gallons of paint, and so on. We see that a house of area A requires $A/250$ gallons of paint, so n and A are related by the formula

$$n = f(A) = \frac{A}{250}.$$

- The input of the function $n = f(A)$ is an area and the output is an amount of paint. The statement $f(10,000) = 40$ tells us that an area of $A = 10,000$ ft² requires $n = 40$ gallons of paint.

Functions Don't Have to Be Defined by Formulas

People sometimes think that functions are always represented by formulas. However, other representations, such as tables or graphs, can be useful.

Example 4 The average monthly rainfall, R , at Chicago's O'Hare airport is given in Table 1.2, where time, t , is in months and $t = 1$ is January, $t = 2$ is February, and so on. The rainfall is a function of the month, so we write $R = f(t)$. However, there is no formula that gives R when t is known. Evaluate $f(1)$ and $f(11)$. Explain what your answers mean.

Table 1.2 Average monthly rainfall at Chicago's O'Hare airport

Month, t	1	2	3	4	5	6	7	8	9	10	11	12
Rainfall, R (inches)	1.8	1.8	2.7	3.1	3.5	3.7	3.5	3.4	3.2	2.5	2.4	2.1

Solution The value of $f(1)$ is the average rainfall in inches at Chicago's O'Hare airport in a typical January. From the table, $f(1) = 1.8$ inches. Similarly, $f(11) = 2.4$ means that in a typical November, there are 2.4 inches of rain at O'Hare.

When Is a Relationship Not a Function?

It is possible for two quantities to be related and yet for neither quantity to be a function of the other.

Example 5 A national park contains foxes that prey on rabbits. Table 1.3 gives the two populations, F and R , over a 12-month period, where $t = 0$ means January 1, $t = 1$ means February 1, and so on.

Table 1.3 Number of foxes and rabbits in a national park, by month

t , month	0	1	2	3	4	5	6	7	8	9	10	11
R , rabbits	1000	750	567	500	567	750	1000	1250	1433	1500	1433	1250
F , foxes	150	143	125	100	75	57	50	57	75	100	125	143

- (a) Is F a function of t ? Is R a function of t ?
 (b) Is F a function of R ? Is R a function of F ?

Solution

- (a) Remember that for a relationship to be a function, an input can only give a single output. Both F and R are functions of t . For each value of t , there is exactly one value of F and exactly one value of R . For example, Table 1.3 shows that if $t = 5$, then $R = 750$ and $F = 57$. This means that on June 1 there are 750 rabbits and 57 foxes in the park. If we write $R = f(t)$ and $F = g(t)$, then $f(5) = 750$ and $g(5) = 57$.
 (b) No, F is not a function of R . For example, suppose $R = 750$, meaning there are 750 rabbits. This happens both at $t = 1$ (February 1) and at $t = 5$ (June 1). In the first instance, there are 143 foxes; in the second instance, there are 57 foxes. Since there are R -values which correspond to more than one F -value, F is not a function of R .

Similarly, R is not a function of F . At time $t = 5$, we have $R = 750$ when $F = 57$, while at time $t = 7$, we have $R = 1250$ when $F = 57$ again. Thus, the value of F does not uniquely determine the value of R .

How to Tell if a Graph Represents a Function: Vertical Line Test

What does it mean graphically for y to be a function of x ? Look at a graph of y against x , with y on the vertical axis and x on the horizontal axis. For a function, each x -value corresponds to exactly one y -value. This means that the graph intersects any vertical line at most once (either once or not at all). If a vertical line cuts the graph twice, the graph contains two points with different y -values but the same x -value; this violates the definition of a function. Thus, we have the following criterion:

Vertical Line Test: If there is a vertical line that intersects a graph in more than one point, then the graph does not represent a function.

Example 6 In which of the graphs in Figures 1.2 and 1.3 could y be a function of x ?

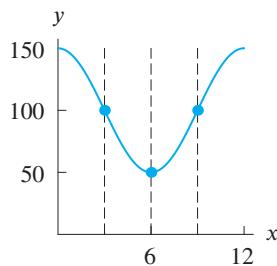

Figure 1.2: Since no vertical line intersects this curve at more than one point, y could be a function of x

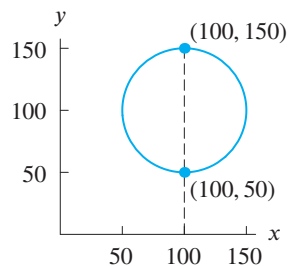

Figure 1.3: Since one vertical line intersects this curve at more than one point, y is not a function of x

Solution The graph in Figure 1.2 could represent y as a function of x because no vertical line intersects this curve in more than one point. The graph in Figure 1.3 does not represent a function because the vertical line shown intersects the curve at two points.

A graph fails the vertical line test if at least one vertical line cuts the graph more than once, as in Figure 1.3. However, if a graph represents a function, then *every* vertical line must intersect the graph at no more than one point.

Exercises and Problems for Section 1.1

Skill Refresher

In Exercises S1–S4, simplify each expression.

S1. $c + \frac{1}{2}c$

S2. $P + 0.07P + 0.02P$

S3. $2\pi r^2 + 2\pi r \cdot 2r$

S4. $\frac{12\pi - 2\pi}{6\pi}$

In Exercises S5–S8, find the value of the expressions for the given value of x and y .

S5. $x - 5y$ for $x = \frac{1}{2}$, $y = -5$.

S6. $1 - 12x + x^2$ for $x = 3$.

S7. $\frac{3}{2 - x^3}$ for $x = -1$.

S8. $\frac{4}{1 + 1/x}$ for $x = -\frac{3}{4}$.

The figures in Exercises S9–S10 are parallelograms. Find the coordinates of the point A .

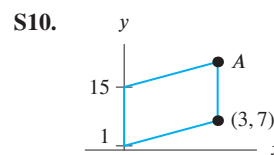
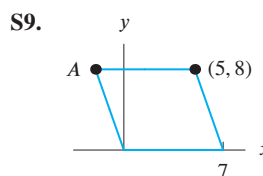

Exercises

In Exercises 1–2, write the relationship using function notation (that is, y is a function of x is written $y = f(x)$).

- Number of molecules, m , in a gas, is a function of the volume of the gas, v .
- Weight, w , is a function of caloric intake, c .

In Exercises 3–6, label the axes for a sketch to illustrate the given statement.

- “Over the past century we have seen changes in the population, P (in millions), of the city. . .”
- “Sketch a graph of the cost of manufacturing q items. . .”
- “Graph the pressure, p , of a gas as a function of its volume, v , where p is in pounds per square inch and v is in cubic inches.”
- “Graph D in terms of y . . .”
- Figure 1.4 gives the depth of the water at Montauk Point, New York, for a day in November.

- How many high tides took place on this day?
- How many low tides took place on this day?
- How much time elapsed in between high tides?

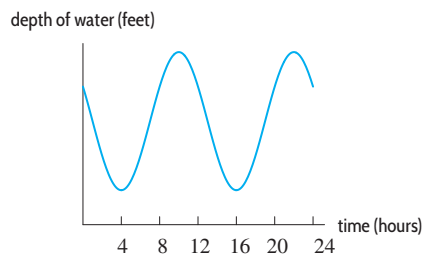

Figure 1.4

- Using Table 1.4, graph $n = f(A)$, the number of gallons of paint needed to cover walls of area A . Identify the independent and dependent variables.

Table 1.4

A	0	250	500	750	1000	1250	1500
n	0	1	2	3	4	5	6

9. Use Figure 1.5 to fill in the missing values:

- (a) $f(0) = ?$ (b) $f(?) = 0$

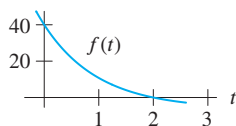

Figure 1.5

10. Use Table 1.5 to fill in the missing values. (There may be more than one answer.)

- (a) $f(0) = ?$ (b) $f(?) = 0$
 (c) $f(1) = ?$ (d) $f(?) = 1$

Table 1.5

x	0	1	2	3	4
$f(x)$	4	2	1	0	1

Exercises 11–14 use Figure 1.6.

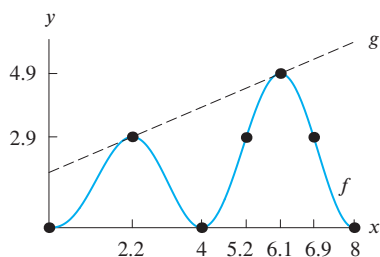

Figure 1.6

11. Find $f(6.9)$.
 12. Give the coordinates of two points on the graph of g .
 13. Solve $f(x) = 0$ for x .
 14. Solve $f(x) = g(x)$ for x .

15. (a) You are going to graph $p = f(w)$. Which variable goes on the horizontal axis?
 (b) If $10 = f(-4)$, give the coordinates of a point on the graph of f .
 (c) If 6 is a solution of the equation $f(w) = 1$, give a point on the graph of f .

In Exercises 16–19 a relationship is given between two quantities. Are both quantities functions of the other one, or is one or neither a function of the other? Explain.

16. $7w^2 + 5 = z^2$ 17. $y = x^4 - 1$ 18. $m = \sqrt{t}$

19. The number of gallons of gas, g , at \$3 per gallon and the number of pounds of coffee, c , at \$10 per pound that can be bought for a total of \$100.

In Exercises 20–25, could the graph represent y as a function of x ?

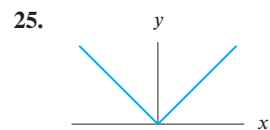
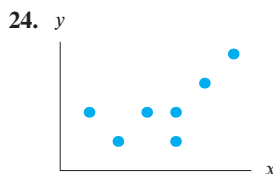
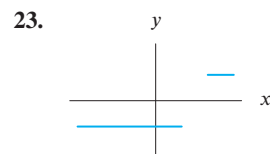
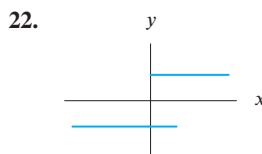
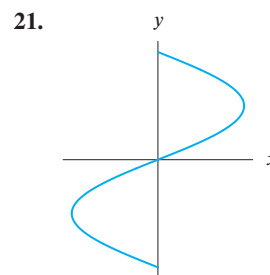
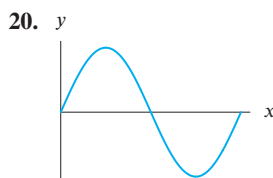

Problems

26. At the end of a semester, students' math grades are listed in a table which gives each student's ID number in the left column and the student's grade in the right column. Let N represent the ID number and G represent the grade. Which quantity, N or G , must necessarily be a function of the other?
 27. A person's blood sugar level at a particular time of the day is partially determined by the time of the most recent meal. After a meal, blood sugar level increases rapidly, then slowly comes back down to a normal level. Sketch a person's blood sugar level as a function of time over the

course of a day. Label the axes to indicate normal blood sugar level and the time of each meal.

28. When a parachutist jumps out of a plane, the speed of her fall increases until she opens her parachute, at which time her falling speed suddenly decreases and stays constant until she reaches the ground. Sketch a possible graph of the height H of the parachutist as a function of time t , from the time when she jumps from the plane to the time when she reaches the ground.
 29. A buzzard is circling high overhead when it spies some road kill. It swoops down, lands, and eats. Later it takes

off sluggishly, and resumes circling overhead, but at a lower altitude. Sketch a possible graph of the height of the buzzard as a function of time.

30. Table 1.6 gives the ranking r for three different names—Hannah, Alexis, and Madison. Of the three names, which was most popular and which was least popular in
- (a) 1995? (b) 2004?

Table 1.6 Ranking of names—Hannah (r_h), Alexis (r_a), and Madison (r_m)—for girls born between 1995 ($t = 0$) and 2004 ($t = 9$)²

t	0	1	2	3	4	5	6	7	8	9
r_h	7	7	5	2	2	2	3	3	4	5
r_a	14	8	8	6	3	6	5	5	7	11
r_m	29	15	10	9	7	3	2	2	3	3

31. Table 1.6 gives information about the popularity of the names Hannah, Madison, and Alexis. Describe in words what your answers to parts (a)–(c) tell you about these names.
- (a) Evaluate $r_m(0) - r_h(0)$.
 (b) Evaluate $r_m(9) - r_h(9)$.
 (c) Solve $r_m(t) < r_a(t)$.

32. Figure 1.7 shows the fuel consumption (in miles per gallon, mpg) of a car traveling at various speeds (in mph).
- (a) How much gas is used on a 300-mile trip at 40 mph?
 (b) How much gas is saved by traveling 60 mph instead of 70 mph on a 200-mile trip?
 (c) According to this graph, what is the most fuel-efficient speed to travel? Explain.

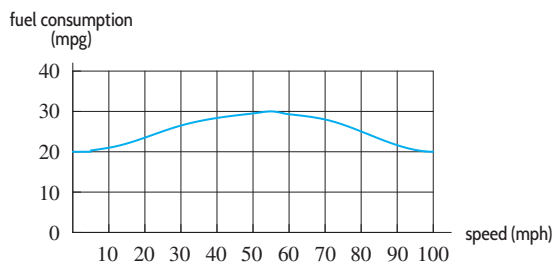
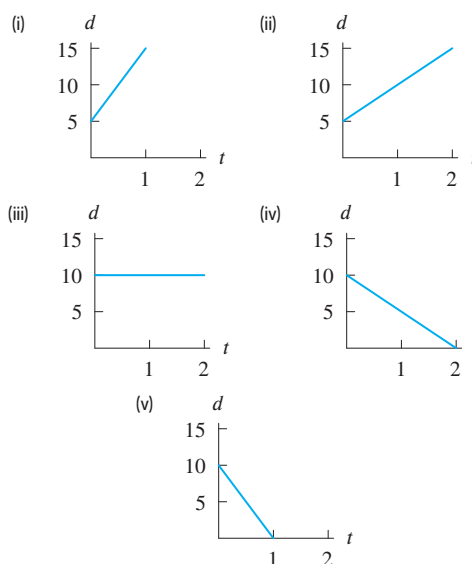

Figure 1.7

33. Match each story about a bike ride to one of the graphs (i)–(v), where d represents distance from home and t is time in hours since the start of the ride. (A graph may be used more than once.)
- (a) Starts 5 miles from home and rides 5 miles per hour away from home.
 (b) Starts 5 miles from home and rides 10 miles per hour away from home.
 (c) Starts 10 miles from home and arrives home one hour later.

- (d) Starts 10 miles from home and is halfway home after one hour.
 (e) Starts 5 miles from home and is 10 miles from home after one hour.



34. Figure 1.8 shows the mass of water in air, in grams of water per kilogram of air, as a function of air temperature in $^{\circ}\text{C}$, for two different levels of relative humidity.
- (a) Find the mass of water in 1 kg of air at 30°C if the relative humidity is
- (a) 100% (b) 50% (c) 75%
- (b) How much water is in a room containing 300 kg of air if the relative humidity is 50% and the temperature is 20°C ?
- (c) The density of air is approximately 1.2 kg/m^3 . If the relative humidity in your classroom is 50% and the temperature is 20°C , estimate the amount of water in the air.

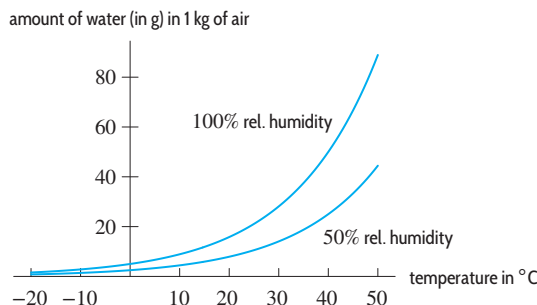

Figure 1.8

²Data from the SSA website at www.ssa.gov, accessed January 12, 2006.

35. Let $f(t)$ be the number of people, in millions, who own cell phones t years after 1990. Explain the meaning of the following statements.
- (a) $f(10) = 100.3$ (b) $f(a) = 20$
 (c) $f(20) = b$ (d) $n = f(t)$
36. (a) Ten inches of snow is equivalent to about one inch of rain.³ Write an equation for the amount of precipitation, measured in inches of rain, $r = f(s)$, as a function of the number of inches of snow, s .
 (b) Evaluate and interpret $f(5)$.
 (c) Find s such that $f(s) = 5$ and interpret your result.
37. An 8-foot-tall cylindrical water tank has a base of diameter 6 feet.
- (a) How much water can the tank hold?
 (b) How much water is in the tank if the water is 5 feet deep?
 (c) Write a formula for the volume of water as a function of its depth in the tank.
38. Table 1.7 gives $A = f(d)$, the amount of money in bills of denomination d circulating in US currency in 2013.⁴ For example, there were \$74.5 billion worth of \$50 bills in circulation.
- (a) Find $f(100)$. What does this tell you about money?
 (b) Are there more \$1 bills or \$5 bills in circulation?

Table 1.7

Denomination (\$)	1	2	5	10	20	50	100
Circulation (\$bn)	10.6	2.1	12.7	18.5	155.0	74.5	924.7

39. Table 1.8 shows the daily low temperature for a one-week period in New York City during July.
- (a) What was the low temperature on July 19?
 (b) When was the low temperature 73°F?
 (c) Is the daily low temperature a function of the date?
 (d) Is the date a function of the daily low temperature?

Table 1.8

Date	17	18	19	20	21	22	23
Low temp (°F)	73	77	69	73	75	75	70

40. Use the data from Table 1.3 on page 5.
- (a) Plot R on the vertical axis and t on the horizontal axis. Use this graph to explain why you believe that R is a function of t .
- (b) Plot F on the vertical axis and t on the horizontal axis. Use this graph to explain why you believe that F is a function of t .
 (c) Plot F on the vertical axis and R on the horizontal axis. From this graph show that F is not a function of R .
 (d) Plot R on the vertical axis and F on the horizontal axis. From this graph show that R is not a function of F .
41. Since Roger Bannister broke the 4-minute mile on May 6, 1954, the record has been lowered by over sixteen seconds. Table 1.9 shows the year and times (as min:sec) of new world records for the one-mile run.⁵ (Official records for the mile ended in 1999.)
- (a) Is the time a function of the year? Explain.
 (b) Is the year a function of the time? Explain.
 (c) Let $y(r)$ be the year in which the world record, r , was set. Explain what is meant by the statement $y(3 : 47.33) = 1981$.
 (d) Evaluate and interpret $y(3 : 51.1)$.

Table 1.9

Year	Time	Year	Time	Year	Time
1954	3:59.4	1966	3:51.3	1981	3:48.53
1954	3:58.0	1967	3:51.1	1981	3:48.40
1957	3:57.2	1975	3:51.0	1981	3:47.33
1958	3:54.5	1975	3:49.4	1985	3:46.32
1962	3:54.4	1979	3:49.0	1993	3:44.39
1964	3:54.1	1980	3:48.8	1999	3:43.13
1965	3:53.6				

42. The sales tax on an item is 6%. Express the total cost, C , in terms of the price of the item, P .
43. A price increases 5% due to inflation and is then reduced 10% for a sale. Express the final price as a function of the original price, P .
44. Write a formula for the area of a circle as a function of its radius and determine the percent increase in the area if the radius is increased by 10%.
45. There are x male job-applicants at a certain company and y female applicants. Suppose that 15% of the men are accepted and 18% of the women are accepted. Write an expression in terms of x and y representing each of the following quantities:
- (a) The total number of applicants to the company.
 (b) The total number of applicants accepted.
 (c) The percentage of all applicants accepted.

³<http://mo.water.usgs.gov/outreach/rain>, accessed May 7, 2006.

⁴http://www.federalreserve.gov/paymentsystems/coin_currircvalue.htm, accessed February 16, 2014.

⁵www.infoplease.com/ipsa/A0112924.html, accessed January 15, 2006.

46. A chemical company spends \$2 million to buy machinery before it starts producing chemicals. Then it spends \$0.5 million on raw materials for each million liters of chemical produced.
- (a) The number of liters produced ranges from 0 to 5 million. Make a table showing the relationship between the number of million liters produced, l , and the total cost, C , in millions of dollars, to produce that number of million liters.
 - (b) Find a formula that expresses C as a function of l .
47. A person leaves home and walks due west for a time and then walks due north.
- (a) The person walks 10 miles in total. If w represents the (variable) distance west she walks, and D represents her (variable) distance from home at the end of her walk, is D a function of w ? Why or why not?
 - (b) Suppose now that x is the distance that she walks in total. Is D a function of x ? Why or why not?

1.2 RATE OF CHANGE

The worldwide annual sales of smartphones have increased each year from when they were first introduced. To measure how fast sales increase, we calculate a *rate of change* in number of units sold

$$\frac{\text{Change in units sold}}{\text{Change in time}}$$

Due to the rising popularity of smartphones, annual sales of regular cell phones, or *feature phones*, have been declining. See Table 1.10.

Let us calculate the rate of change of smartphone and feature phone sales between 2010 and 2013. Table 1.10 gives

$$\begin{aligned} \text{Average rate of change of} \\ \text{smartphone sales from 2010 to 2013} \end{aligned} = \frac{\text{Change in sales}}{\text{Change in time}} = \frac{968 - 301}{2013 - 2010} \approx 222.3 \text{ mn / year.}$$

Thus, the number of smartphones sold has increased on average by 222.3 million units per year between 2010 and 2013. See Figure 1.9. Similarly, Table 1.10 gives

$$\begin{aligned} \text{Average rate of change of feature phone} \\ \text{sales from 2010 to 2013} \end{aligned} = \frac{\text{Change in sales}}{\text{Change in time}} = \frac{838 - 1079}{2013 - 2010} \approx -80.3 \text{ mn / year.}$$

Thus, the number of feature phones sold has decreased on average by 80.3 million units per year between 2010 and 2013. See Figure 1.10.

Table 1.10 Worldwide annual sales of smartphones and feature phones⁶

Year	2010	2011	2012	2013
Smartphone sales (millions of units)	301	480	661	968
Feature phone sales (millions of units)	1079	1075	914	838

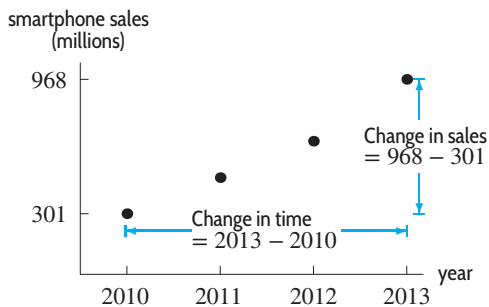

Figure 1.9: Smartphone sales

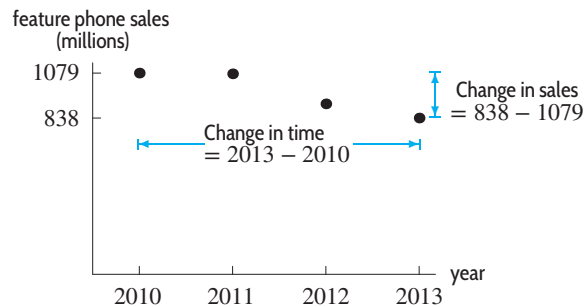

Figure 1.10: Feature phone sales

⁶ Accessed Feb. 14 2014, www.fiercewireless.com/europe/story/gartner-smartphones-outsell-feature-phones-2013/2014-02-13 and www.fiercewireless.com/europe/special-reports/analyzing-worlds-14-biggest-handset-makers-q2-2013

Rate of Change of a Function

The rate of change of sales is an example of the rate of change of a function. In general, if $Q = f(t)$, we write ΔQ for a change in Q and Δt for a change in t . We define:⁷

The **average rate of change**, or **rate of change**, of Q with respect to t over an interval is

$$\begin{array}{l} \text{Average rate of change} \\ \text{over an interval} \end{array} = \frac{\text{Change in } Q}{\text{Change in } t} = \frac{\Delta Q}{\Delta t}.$$

The average rate of change of the function $Q = f(t)$ over an interval tells us how much Q changes, on average, for each unit change in t within that interval. On some parts of the interval, Q may be changing rapidly, while on other parts Q may be changing slowly. The average rate of change evens out these variations.

Increasing and Decreasing Functions

In the previous example, the average rate of change of smartphone sales is positive on the interval from 2010 to 2013 since the number of smartphones sold increased over this interval. Similarly, the average rate of change of feature phone sales is negative on the same interval since the number of feature phones sold decreased over this interval. The annual sales of smartphones is an example of an *increasing function* and the annual sales of feature phones is an example of a *decreasing function*. In general we say the following:

- If $Q = f(t)$ for t in the interval $a \leq t \leq b$,
- f is an **increasing function** if the values of f increase as t increases in this interval.
 - f is a **decreasing function** if the values of f decrease as t increases in this interval.

Looking at smartphone sales, we see that an increasing function has a positive rate of change. From the feature phone sales, we see that a decreasing function has a negative rate of change. In general:

- If $Q = f(t)$,
- If f is an increasing function, then the average rate of change of Q with respect to t is positive on every interval.
 - If f is a decreasing function, then the average rate of change of Q with respect to t is negative on every interval.

Example 1 The function $A = q(r) = \pi r^2$ gives the area, A , of a circle as a function of its radius, r . Graph q . Explain how the fact that q is an increasing function can be seen on the graph.

Solution The area increases as the radius increases, so $A = q(r)$ is an increasing function. We can see this in Figure 1.11 because the graph climbs as we move from left to right and the average rate of change, $\Delta A/\Delta r$, is positive on every interval.

⁷The Greek letter Δ , delta, is often used in mathematics to represent change. In this book, we use rate of change to mean average rate of change across an interval. In calculus, rate of change means something called instantaneous rate of change.

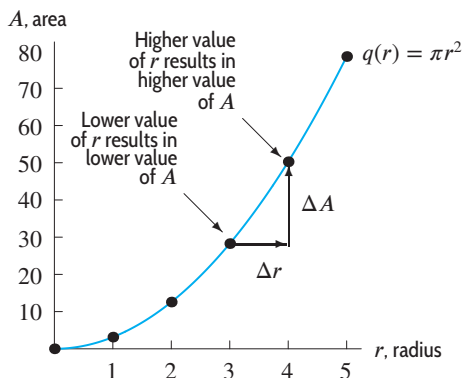

Figure 1.11: The graph of an increasing function, $A = q(r)$, rises when read from left to right

Example 2 Carbon-14 is a radioactive element that exists naturally in the atmosphere and is absorbed by living organisms. When an organism dies, the carbon-14 present at death begins to decay. Let $L = g(t)$ represent the quantity of carbon-14 (in micrograms, μg) in a tree t years after its death. See Table 1.11. Explain why we expect g to be a decreasing function of t and how the graph displays this.

Table 1.11 Quantity of carbon-14 as a function of time

t , time (years)	0	1000	2000	3000	4000	5000
L , quantity of carbon-14 (μg)	200	177	157	139	123	109

Solution Since the amount of carbon-14 is decaying over time, g is a decreasing function. In Figure 1.12, the graph falls as we move from left to right and the average rate of change in the level of carbon-14 with respect to time, $\Delta L/\Delta t$, is negative on every interval.

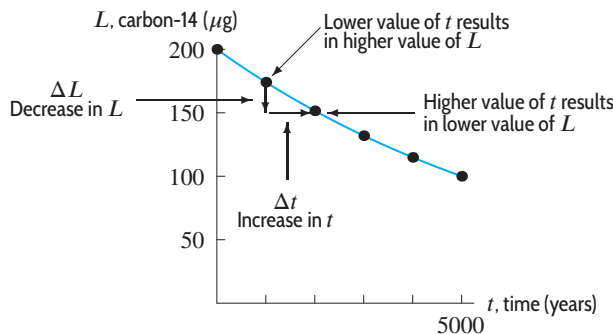

Figure 1.12: The graph of a decreasing function, $L = g(t)$, falls when read from left to right

In general, we can identify an increasing or decreasing function from its graph as follows:

- The graph of an increasing function rises when read from left to right.
- The graph of a decreasing function falls when read from left to right.

Many functions have some intervals on which they are increasing and other intervals on which they are decreasing. These intervals can often be identified from the graph.

Example 3 On what intervals is the function graphed in Figure 1.13 increasing? Decreasing?

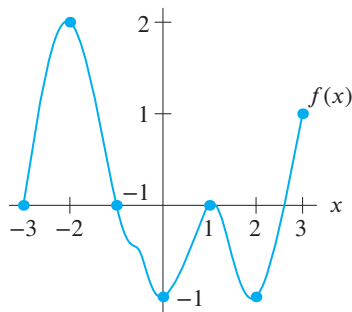

Figure 1.13: Graph of a function that is increasing on some intervals and decreasing on others

Solution The function appears to be increasing for values of x between -3 and -2 , for x between 0 and 1 , and for x between 2 and 3 . The function appears to be decreasing for x between -2 and 0 and for x between 1 and 2 . Using inequalities, we say that f is increasing for $-3 < x < -2$, for $0 < x < 1$, and for $2 < x < 3$. Similarly, f is decreasing for $-2 < x < 0$ and $1 < x < 2$.

Function Notation for the Average Rate of Change

Suppose we want to find the average rate of change of a function $Q = f(t)$ over the interval $a \leq t \leq b$. On this interval, the change in t is given by

$$\Delta t = b - a.$$

At $t = a$, the value of Q is $f(a)$, and at $t = b$, the value of Q is $f(b)$. Therefore, the change in Q is given by

$$\Delta Q = f(b) - f(a).$$

Using function notation, we express the average rate of change as follows:

$$\text{Average rate of change of } Q = f(t) \text{ over the interval } a \leq t \leq b = \frac{\text{Change in } Q}{\text{Change in } t} = \frac{\Delta Q}{\Delta t} = \frac{f(b) - f(a)}{b - a}.$$

In Figure 1.14, notice that the average rate of change is given by the ratio of the rise, $f(b) - f(a)$, to the run, $b - a$. This ratio is also called the *slope* of the dashed line segment.⁸

In the future, we may drop the word “average” and talk about the rate of change over an interval.

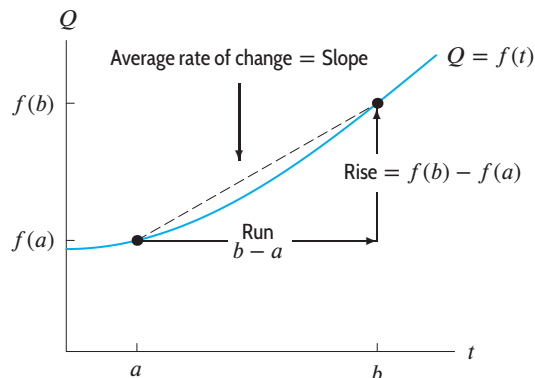

Figure 1.14: The average rate of change is the ratio Rise/Run

⁸See Section 1.3 for further discussion of slope.

In previous examples we calculated the average rate of change from data. We now calculate average rates of change for functions given by formulas.

Example 4 Calculate the average rates of change of the function $f(x) = x^2$ between $x = 1$ and $x = 3$ and between $x = -2$ and $x = 1$. Show your results on a graph.

Solution Between $x = 1$ and $x = 3$, we have

$$\begin{aligned} \text{Average rate of change of } f(x) \text{ over the interval } 1 \leq x \leq 3 &= \frac{\text{Change in } f(x)}{\text{Change in } x} = \frac{f(3) - f(1)}{3 - 1} \\ &= \frac{3^2 - 1^2}{3 - 1} = \frac{9 - 1}{2} = 4. \end{aligned}$$

Between $x = -2$ and $x = 1$, we have

$$\begin{aligned} \text{Average rate of change of } f(x) \text{ over the interval } -2 \leq x \leq 1 &= \frac{\text{Change in } f(x)}{\text{Change in } x} = \frac{f(1) - f(-2)}{1 - (-2)} \\ &= \frac{1^2 - (-2)^2}{1 - (-2)} = \frac{1 - 4}{3} = -1. \end{aligned}$$

The average rate of change between $x = 1$ and $x = 3$ is positive because $f(x)$ is increasing on this interval. See Figure 1.15. However, on the interval from $x = -2$ and $x = 1$, the function is partly decreasing and partly increasing. The average rate of change on this interval is negative because the decrease on the interval is larger than the increase.

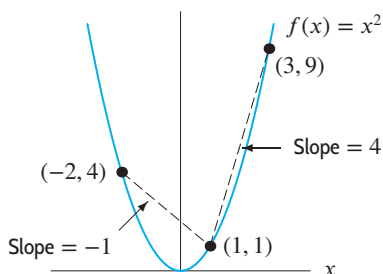

Figure 1.15: Average rate of change of $f(x)$ on an interval is the slope of the dashed line on that interval

Exercises and Problems for Section 1.2

Skill Refresher

In Exercises S1–S10, simplify each expression.

S1. $\frac{4 - 6}{3 - 2}$

S2. $\frac{1 - 3}{2^2 - (-3)^2}$

S3. $\frac{-3 - (-9)}{-1 - 2}$

S4. $\frac{(1 - 3^2) - (1 - 4^2)}{3 - 4}$

S5. $\frac{\frac{1}{2} - (-4)^2 - \left(\frac{1}{2} - (5^2)\right)}{-4 - 5}$

S6. $2(x + a) - 3(x - b)$

S7. $x^2 - (2x + a)^2$

S8. $4x^2 - (x - b)^2$

S9. $\frac{x^2 - \frac{3}{4} - \left(y^2 - \frac{3}{4}\right)}{x - y}$

S10. $\frac{2(x + h)^2 - 2x^2}{(x + h) - x}$

Exercises

In Exercises 1–4, on what intervals is the function increasing? Decreasing?

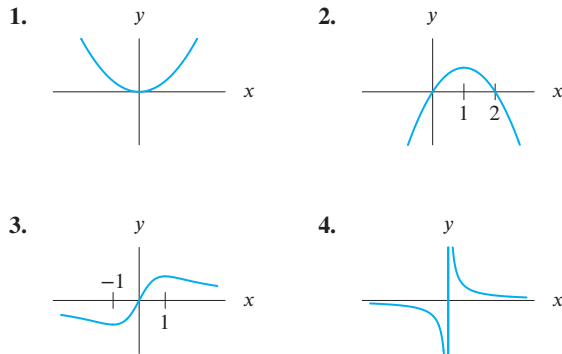

5. Table 1.10 on page 10 gives the annual sales (in millions) of smartphones and feature phones. What was the average rate of change of annual sales of each of them between

(a) 2010 and 2012? (b) 2012 and 2013?

(c) Interpret these results in terms of sales.

6. Table 1.10 on page 10 shows that feature phone sales are a function of smartphone sales. Is this function increasing or decreasing?

7. In 2007, you have 40 songs in your favorite iTunes playlist. In 2010, you have 120 songs. In 2014, you have 40. What is the average rate of change per year in the number of songs in your favorite iTunes playlist between

(a) 2007 and 2010? (b) 2010 and 2014?

(c) 2007 and 2014?

8. Table 1.12 gives the populations of two cities (in thousands) over a 17-year period.

(a) Find the average rate of change of each population on the following intervals:

(i) 1996 to 2006 (ii) 1996 to 2013

(iii) 2001 to 2013

(b) What do you notice about the average rate of change of each population? Explain what the average rate of change tells you about each population.

Table 1.12

Year	1996	1998	2001	2006	2013
P_1	42	46	52	62	76
P_2	82	80	77	72	65

9. Figure 1.16 shows distance traveled as a function of time.

(a) Find ΔD and Δt between:

(i) $t = 2$ and $t = 5$ (ii) $t = 0.5$ and $t = 2.5$

(iii) $t = 1.5$ and $t = 3$

(b) Compute the rate of change, $\Delta D/\Delta t$, over each of the intervals in part (a), and interpret its meaning.

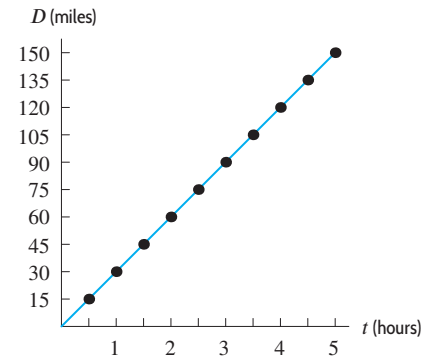

Figure 1.16

Exercises 10–14 use Figure 1.17.

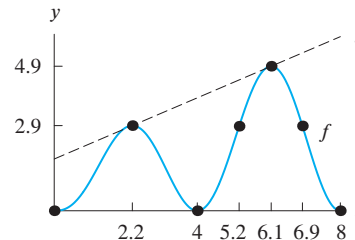

Figure 1.17

10. Find the average rate of change of f for $2.2 \leq x \leq 6.1$.

11. Give two different intervals on which $\Delta f(x)/\Delta x = 0$.

12. What is the average rate of change of g between $x = 2.2$ and $x = 6.1$?

13. What is the relation between the average rate of change of f and the average rate of change of g between $x = 2.2$ and $x = 6.1$?

14. Is the rate of change of f positive or negative on the following intervals?

(a) $2.2 \leq x \leq 4$

(b) $5 \leq x \leq 6$

15. If F is a decreasing function, what can you say about $F(-2)$ compared to $F(2)$?

16. If G is an increasing function, what can you say about $G(3) - G(-1)$?

Problems

17. Figure 1.18 shows the percent of the side of the moon toward the earth illuminated by the sun at different times during the year 2008. Use the figure to answer the following questions.

- (a) Give the coordinates of the points A, B, C, D, E .
- (b) Plot the point $F = (15, 60)$ and $G = (60, 15)$. Which point is on the graph?
- (c) During which time intervals is the function increasing?
- (d) During which time intervals is the function decreasing?

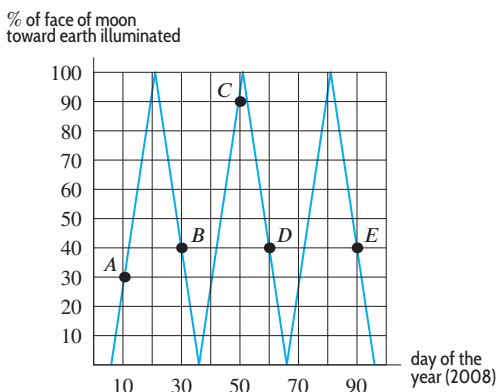

Figure 1.18: Moon phases

18. Figure 1.19 gives the population of two different towns over a 50-year period of time.

- (a) Which town starts (in year $t = 0$) with the most people?
- (b) Which town is growing faster over these 50 years?

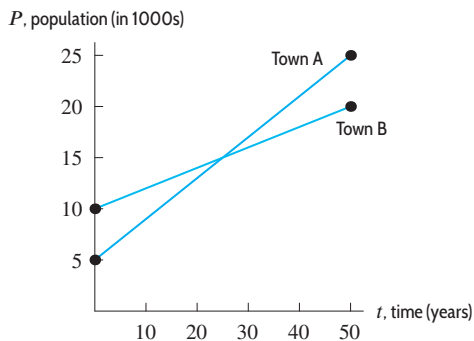

Figure 1.19

19. (a) What is the average rate of change of $g(x) = 2x - 3$ between the points $(-2, -7)$ and $(3, 3)$?

(b) Based on your answer to part (a), is g increasing or decreasing on the given interval? Explain.

(c) Graph the function and determine over what intervals g is increasing and over what intervals g is decreasing.

20. (a) Let $f(x) = 16 - x^2$. Compute each of the following expressions, and interpret each as an average rate of change.

(i) $\frac{f(2) - f(0)}{2 - 0}$ (ii) $\frac{f(4) - f(2)}{4 - 2}$
 (iii) $\frac{f(4) - f(0)}{4 - 0}$

(b) Graph $f(x)$. Illustrate each ratio in part (a) by sketching the line segment with the given slope. Over which interval is the average rate of decrease the greatest?

21. Imagine you constructed a list of the world record times for a particular event—such as the mile footrace, or the 100-meter freestyle swimming race—in terms of when they were established. Is the world record time a function of the date when it was established? If so, is this function increasing or decreasing? Explain. Could a world record be established twice in the same year? Is the world record time a function of the year it was established?

22. The function $P = f(t)$ gives the population of a town, in thousands, after t years. A graph of f is given in Figure 1.20.

(a) Find the average rate of change of the population of the town during the first 10 years.

(b) Does the population of the town grow more between $t = 5$ and $t = 10$ years, or between $t = 15$ and $t = 30$ years? Explain.

(c) Does the population of the town grow faster between $t = 5$ and $t = 10$ years, or between $t = 15$ and $t = 30$ years? Explain.

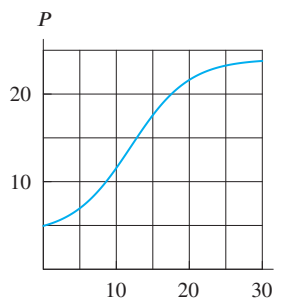

Figure 1.20

23. The most freakish change in temperature ever recorded was from -4°F to 45°F between 7:30 am and 7:32 am on January 22, 1943 at Spearfish, South Dakota.⁹ What was the average rate of change of the temperature for this time period?
24. You have zero dollars now and the average rate of change in your net worth is \$5000 per year. How much money will you have in forty years?
25. The surface of the sun has dark areas known as sunspots, that are cooler than the rest of the sun's surface. The number of sunspots¹⁰ fluctuates with time, as shown in Figure 1.21.
- (a) Explain how you know the number of sunspots, s , in year t is a function of t .
- (b) Approximate the time intervals on which s is an increasing function of t .

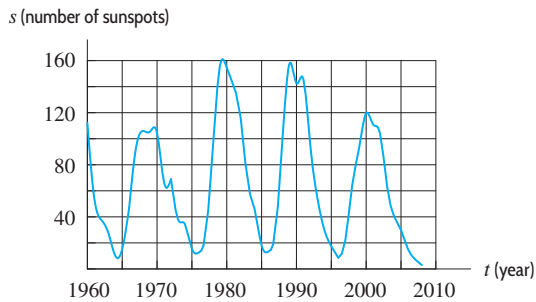

Figure 1.21

26. Table 1.13 shows the number of calories used per minute as a function of body weight for three sports.¹¹
- (a) Determine the number of calories that a 200-lb person uses in one half-hour of walking.
- (b) Who uses more calories, a 120-lb person swimming for one hour or a 220-lb person bicycling for a half-hour?
- (c) Does the number of calories used by a person walking increase or decrease as weight increases?

Table 1.13

Activity	100 lb	120 lb	150 lb	170 lb	200 lb	220 lb
Walking	2.7	3.2	4.0	4.6	5.4	5.9
Bicycling	5.4	6.5	8.1	9.2	10.8	11.9
Swimming	5.8	6.9	8.7	9.8	11.6	12.7

27. Because scientists know how much carbon-14 a living organism should have in its tissues, they can measure the amount of carbon-14 present in the tissue of a fossil and then calculate how long it took for the original amount to decay to the current level, thus determining the time of the organism's death. A tree fossil is found to contain $130\ \mu\text{g}$ of carbon-14, and scientists determine from the size of the tree that it would have contained $200\ \mu\text{g}$ of carbon-14 at the time of its death. Using Table 1.11 on page 12, approximately how long ago did the tree die?
28. Figure 1.22 shows the graph of the function $g(x)$.

- (a) Estimate $\frac{g(4) - g(0)}{4 - 0}$.
- (b) The ratio in part (a) is the slope of a line segment joining two points on the graph. Sketch this line segment on the graph.
- (c) Estimate $\frac{g(b) - g(a)}{b - a}$ for $a = -9$ and $b = -1$.
- (d) On the graph, sketch the line segment whose slope is given by the ratio in part (c).

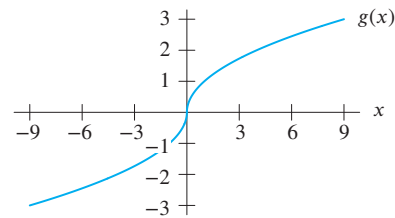

Figure 1.22

29. Find the average rate of change of $f(x) = 3x^2 + 1$ between the points
- (a) $(1, 4)$ and $(2, 13)$ (b) (j, k) and (m, n)
- (c) $(x, f(x))$ and $(x+h, f(x+h))$
30. A water company employee measured the water level (in centimeters) in a reservoir during March and computed the average rates of change in Table 1.14.
- (a) What are the units of the average rates of change in Table 1.14?
- (b) Interpret the average rates of change in context.
- (c) For each time interval, what was the total change in water level?
- (d) Draw a possible graph of the water level as a function of time.

Table 1.14

Interval (days)	$1 \leq t < 11$	$11 \leq t < 16$	$16 \leq t < 31$
Average rate of change	7	5	3

⁹The Guinness Book of Records. 1995.

¹⁰[ftp://ftp.ngdc.noaa.gov/STP/SOLAR_DATA/SUNSPOT_NUMBERS/YEARLY.PLT](http://ftp.ngdc.noaa.gov/STP/SOLAR_DATA/SUNSPOT_NUMBERS/YEARLY.PLT), accessed November 30, 2009.

¹¹From 1993 World Almanac.

31. Table 1.15 gives the amount of garbage, G , in millions of tons, produced¹² in the US in year t .
- What is the value of Δt for consecutive entries in this table?
 - Calculate the value of ΔG for each pair of consecutive entries in this table.
 - Are all the values of ΔG you found in part (b) the same? What does this tell you?
 - The function G changed from increasing to decreasing between 2005 and 2010. To what might this be attributed?

Table 1.15

t	1960	1970	1980	1990	2000	2005	2010
G	88.1	121.1	151.6	208.3	242.5	252.7	249.9

32. Table 1.16 shows the times, t , in sec, achieved every 10 meters by Carl Lewis in the 100-meter final of the World

Championship in Rome in 1987.¹³ Distance, d , is in meters.

- For each successive time interval, calculate the average rate of change of distance. What is a common name for the average rate of change of distance?
- Where did Carl Lewis attain his maximum speed during this race? Some runners are running their fastest as they cross the finish line. Does that seem to be true in this case?

Table 1.16

t	0.00	1.94	2.96	3.91	4.78	5.64
d	0	10	20	30	40	50
t	6.50	7.36	8.22	9.07	9.93	
d	60	70	80	90	100	

1.3 LINEAR FUNCTIONS

Constant Rate of Change

In the previous section, we introduced the average rate of change of a function on an interval. For many functions, the average rate of change is different on different intervals. For the remainder of this chapter, we consider functions that have the same average rate of change on every interval. Such a function has a graph that is a line and is called *linear*.

Population Growth

Mathematical models of population growth are used by city planners to project the growth of towns and states. Biologists model the growth of animal populations and physicians model the spread of an infection in the bloodstream. One possible model, a linear model, assumes that the population changes at the same average rate on every time interval.

Example 1 A town of 30,000 people grows by 2000 people every year. Since the population, P , is growing at the constant rate of 2000 people per year, P is a linear function of time, t , in years.

- What is the average rate of change of P over every time interval?
- Make a table that gives the town's population every five years over a 20-year period. Graph the population.
- Find a formula for P as a function of t .

Solution

- The average rate of change of population with respect to time is 2000 people per year.
- The initial population in year $t = 0$ is $P = 30,000$ people. Since the town grows by 2000 people every year, after five years it has grown by

$$\frac{2000 \text{ people}}{\text{year}} \cdot 5 \text{ years} = 10,000 \text{ people.}$$

Thus, in year $t = 5$ the population is given by

$$P = \text{Initial population} + \text{New population} = 30,000 + 10,000 = 40,000.$$

¹²http://www.epa.gov/osw/nonhaz/municipal/pubs/msw_2010_rev_factsheet.pdf, accessed January, 2013.

¹³W. G. Pritchard, "Mathematical Models of Running", *SIAM Review*. 35, 1993, pp. 359–379.

In year $t = 10$ the population is given by

$$P = 30,000 + \underbrace{2000 \text{ people/year} \cdot 10 \text{ years}}_{20,000 \text{ new people}} = 50,000.$$

Similar calculations for year $t = 15$ and year $t = 20$ give the values in Table 1.17. See Figure 1.23; the dashed line shows the trend in the data.

Table 1.17 Population over 20 years

t , years	P , population
0	30,000
5	40,000
10	50,000
15	60,000
20	70,000

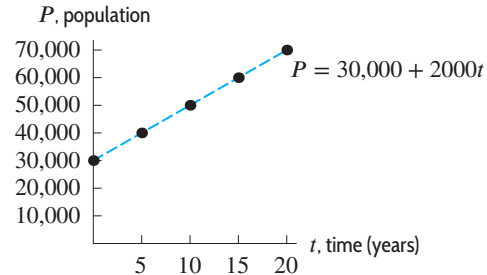

Figure 1.23: Town's population over 20 years

(c) From part (b), we see that the size of the population is given by

$$\begin{aligned} P &= \text{Initial population} + \text{Number of new people} \\ &= 30,000 + 2000 \text{ people/year} \cdot \text{Number of years,} \end{aligned}$$

so a formula for P in terms of t is

$$P = 30,000 + 2000t.$$

The graph of the population data in Figure 1.23 is a straight line. The average rate of change of the population over every interval is the same, namely 2000 people per year. Any linear function has the same average rate of change over every interval. Thus, we talk about *the* rate of change of a linear function. In general:

- A **linear function** has a constant rate of change.
- The graph of any linear function is a straight line.

Financial Models

Economists and accountants use linear functions for *straight-line depreciation*. For tax purposes, the value of certain equipment is considered to decrease, or depreciate, over time. For example, computer equipment may be state-of-the-art today, but after several years it is outdated. Straight-line depreciation assumes that the rate of change of value with respect to time is constant.

Example 2 A small business spends \$20,000 on new computer equipment and, for tax purposes, chooses to depreciate it to \$0 at a constant rate over a five-year period.

- Make a table and a graph showing the value of the equipment over the five-year period.
- Give a formula for value as a function of time.

Solution (a) After five years, the equipment is valued at \$0. If V is the value in dollars and t is the number of years, we see that

$$\begin{aligned} \text{Rate of change of value} &= \frac{\text{Change in value}}{\text{Change in time}} = \frac{\Delta V}{\Delta t} = \frac{-\$20,000}{5 \text{ years}} = -\$4000 \text{ per year.} \\ \text{from } t = 0 \text{ to } t = 5 & \end{aligned}$$

Thus, the value drops at the constant rate of \$4000 per year. (Notice that ΔV is negative because the value of the equipment decreases.) See Table 1.18 and Figure 1.24. Since V changes at a constant rate, $V = f(t)$ is a linear function and its graph is a straight line. The rate of change, $-\$4000$ per year, is negative because the function is decreasing and the graph slopes down.

Table 1.18 Value of equipment depreciated over a 5-year period

t , year	V , value (\$)
0	20,000
1	16,000
2	12,000
3	8000
4	4000
5	0

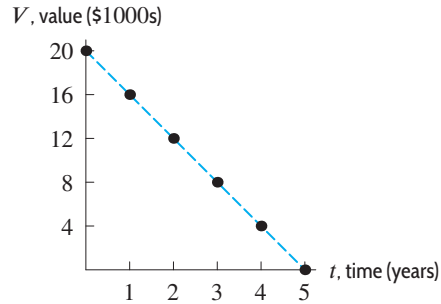

Figure 1.24: Value of equipment depreciated over a 5-year period

(b) After t years have elapsed,

$$\text{Decrease in value of equipment} = \$4000 \cdot \text{Number of years} = \$4000t.$$

The initial value of the equipment is \$20,000, so at time t ,

$$V = 20,000 - 4000t.$$

A General Formula for the Family of Linear Functions

Example 1 involved a town whose population is growing at a constant rate with formula

$$\text{Current population} = \underbrace{\text{Initial population}}_{30,000 \text{ people}} + \underbrace{\text{Growth rate}}_{2000 \text{ people per year}} \times \underbrace{\text{Number of years}}_t$$

so

$$P = 30,000 + 2000t.$$

In Example 2, the value, V , as a function of t is given by

$$\text{Total cost} = \underbrace{\text{Initial value}}_{\$20,000} + \underbrace{\text{Change per year}}_{-\$4000 \text{ per year}} \times \underbrace{\text{Number of years}}_t$$

so

$$V = 20,000 + (-4000)t.$$

Using the symbols x , y , b , m , we see formulas for both of these linear functions follow the same pattern:

$$\underbrace{\text{Output}}_y = \underbrace{\text{Initial value}}_b + \underbrace{\text{Rate of change}}_m \times \underbrace{\text{Input}}_x .$$

Summarizing, we get the following results:

If $y = f(x)$ is a linear function, then for some constants b and m :

$$y = b + mx.$$

- m is called the **slope**, and gives the rate of change of y with respect to x . Thus,

$$m = \frac{\Delta y}{\Delta x}.$$

If (x_0, y_0) and (x_1, y_1) are any two distinct points on the graph of f , then

$$m = \frac{\Delta y}{\Delta x} = \frac{y_1 - y_0}{x_1 - x_0}.$$

- b is called the **vertical intercept**, or **y-intercept**, and gives the value of y for $x = 0$. In mathematical models, b typically represents an initial, or starting, value of the output.

Every linear function can be written in the form $y = b + mx$. Different linear functions have different values for m and b . These constants are known as *parameters*; the set of all linear functions is called a *family*.

Example 3 In Example 1, the population function, $P = 30,000 + 2000t$, has slope $m = 2000$ and vertical intercept $b = 30,000$. In Example 2, the value of the computer equipment, $V = 20,000 - 4000t$, has slope $m = -4000$ and vertical intercept $b = 20,000$.

Tables for Linear Functions

A table of values could represent a linear function if the rate of change is constant, for all pairs of points in the table; that is,

$$\text{Rate of change of linear function} = \frac{\text{Change in output}}{\text{Change in input}} = \text{Constant}.$$

Thus, if the value of x goes up by equal steps in a table for a linear function, then the value of y goes up (or down) by equal steps as well. We say that changes in the value of y are *proportional* to changes in the value of x .

Example 4 Table 1.19 gives values of two functions, p and q . Could either of these functions be linear?

Table 1.19 Values of two functions p and q

x	50	55	60	65	70
$p(x)$	0.10	0.11	0.12	0.13	0.14
$q(x)$	0.01	0.03	0.06	0.14	0.15

Solution The value of x goes up by equal steps of $\Delta x = 5$. The value of $p(x)$ also goes up by equal steps of $\Delta p = 0.01$, so $\Delta p / \Delta x$ is a constant. See Table 1.20. Thus, p could be a linear function.

Table 1.20 Values of $\Delta p/\Delta x$

x	$p(x)$	Δp	$\Delta p/\Delta x$
50	0.10	0.01	0.002
55	0.11	0.01	0.002
60	0.12	0.01	0.002
65	0.13	0.01	0.002
70	0.14		

Table 1.21 Values of $\Delta q/\Delta x$

x	$q(x)$	Δq	$\Delta q/\Delta x$
50	0.01	0.02	0.004
55	0.03	0.03	0.006
60	0.06	0.08	0.016
65	0.14	0.01	0.002
70	0.15		

In contrast, the value of $q(x)$ does not go up by equal steps. The value climbs by 0.02, then by 0.03, and so on. See Table 1.21. This means that $\Delta q/\Delta x$ is not constant. Thus, q could not be a linear function.

It is possible to have data from a linear function in which neither the x -values nor the y -values go up by equal steps. However the rate of change must be constant, as in the following example.

Example 5 The former Republic of Yugoslavia exported cars called Yugos to the US between 1985 and 1989. The car is now a collector’s item.¹⁴ Table 1.22 gives the quantity of Yugos sold, Q , and the price, p , for each year from 1985 to 1988.

- (a) Using Table 1.22, explain why Q could be a linear function of p .
- (b) What does the rate of change of this function tell you about Yugos?

Table 1.22 Price and sales of Yugos in the US

Year	Price in \$, p	Number sold, Q
1985	3990	49,000
1986	4110	43,000
1987	4200	38,500
1988	4330	32,000

Solution (a) We are interested in Q as a function of p , so we plot Q on the vertical axis and p on the horizontal axis. The data points in Figure 1.25 appear to lie on a straight line, suggesting a linear function.

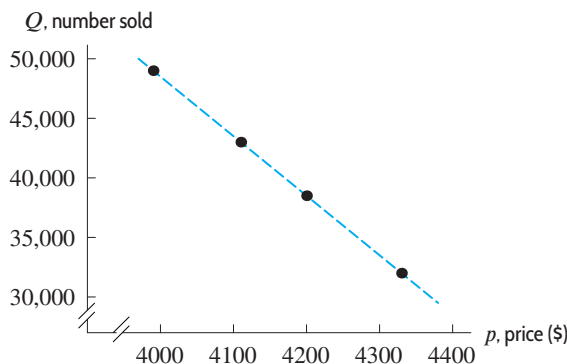

Figure 1.25: Since the data from Table 1.22 falls on a straight line, the table could represent a linear function

¹⁴www.inet.hr/~pauric/epov.htm, accessed January 16, 2006.

To provide further evidence that Q is a linear function, we check that the rate of change of Q with respect to p is constant for the points given. When the price of a Yugo rose from \$3990 to \$4110, sales fell from 49,000 to 43,000. Thus,

$$\Delta p = 4110 - 3990 = 120,$$

$$\Delta Q = 43,000 - 49,000 = -6000.$$

Since the number of Yugos sold decreased, ΔQ is negative. Thus, as the price increased from \$3990 to \$4110,

$$\text{Rate of change of quantity as price increases} = \frac{\Delta Q}{\Delta p} = \frac{-6000}{120} = -50 \text{ cars per dollar.}$$

Next, we calculate the rate of change as the price increased from \$4110 to \$4200 to see if the rate remains constant:

$$\text{Rate of change} = \frac{\Delta Q}{\Delta p} = \frac{38,500 - 43,000}{4200 - 4110} = \frac{-4500}{90} = -50 \text{ cars per dollar,}$$

and as the price increased from \$4200 to \$4330:

$$\text{Rate of change} = \frac{\Delta Q}{\Delta p} = \frac{32,000 - 38,500}{4330 - 4200} = \frac{-6500}{130} = -50 \text{ cars per dollar.}$$

Since the rate of change, -50 , is constant, Q could be a linear function of p . Given additional data, $\Delta Q/\Delta p$ might not remain constant. However, based on the table, it appears that the function is linear.

- (b) Since ΔQ is the change in the number of cars sold and Δp is the change in price, the rate of change is -50 cars per dollar. Thus the number of Yugos sold decreased by 50 each time the price increased by \$1.

Warning: Not All Graphs That Look Like Lines Represent Linear Functions

The graph of any linear function is a line. However, a function's graph can look like a line without actually being one. Consider the following example.

Example 6 The function $P = 100(1.02)^t$ approximates the population of Mexico in the early 2000s. Here P is the population (in millions) and t is the number of years since 2000. Table 1.23 and Figure 1.26 show values of P over a 5-year period. Is P a linear function of t ?

Table 1.23 Population of Mexico t years after 2000

t (years)	P (millions)
0	100
1	102
2	104.04
3	106.12
4	108.24
5	110.41

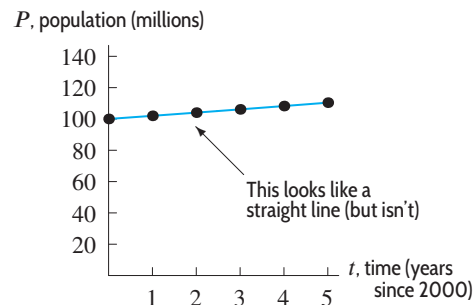

Figure 1.26: Graph of $P = 100(1.02)^t$ over 5-year period: Looks linear (but is not)

Solution The formula $P = 100(1.02)^t$ cannot be written in the form $P = b + mt$, so P is not a linear function of t . However, the graph of P in Figure 1.26 appears to be a straight line. We check P 's rate of change in Table 1.23. When $t = 0$, $P = 100$ and when $t = 1$, $P = 102$. Thus, between 2000 and 2001,

$$\text{Rate of change of population} = \frac{\Delta P}{\Delta t} = \frac{102 - 100}{1 - 0} = 2.$$

For the interval from 2001 to 2002, we have

$$\text{Rate of change} = \frac{\Delta P}{\Delta t} = \frac{104.04 - 102}{2 - 1} = 2.04,$$

and for the interval from 2004 to 2005, we have

$$\text{Rate of change} = \frac{\Delta P}{\Delta t} = \frac{110.41 - 108.24}{5 - 4} = 2.17.$$

Thus, P 's rate of change is not constant. In fact, P appears to be increasing at a faster and faster rate. Table 1.24 and Figure 1.27 show values of P over a longer (60-year) period. On this scale, these points do not appear to fall on a straight line. However, the graph of P curves upward so gradually at first that over the short interval shown in Figure 1.26, it barely curves at all. The graphs of many nonlinear functions, when viewed on a small scale, appear to be linear.

Table 1.24 Population over 60 years

t (years since 2000)	P (millions)
0	100
10	121.90
20	148.59
30	181.14
40	220.80
50	269.16
60	328.10

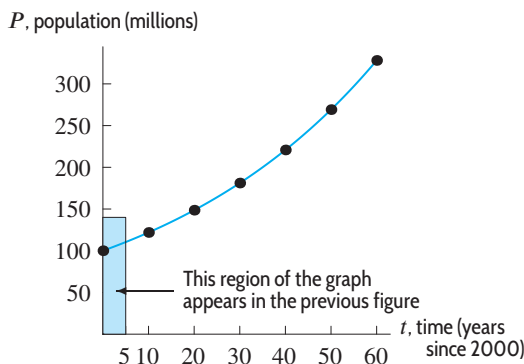

Figure 1.27: Graph of $P = 100(1.02)^t$ over 60 years: Not linear

Exercises and Problems for Section 1.3

Skill Refresher

In Exercises S1–S2, find $f(0)$ and $f(3)$.

S1. $f(x) = \frac{2}{3}x + 5$

S2. $f(t) = 17 - 4t$

In Exercises S5–S6, find the coordinates of the x and y intercepts.

S5. $y = -4x + 3$

S6. $5x - 2y = 4$

In Exercises S3–S4, find $f(2) - f(0)$.

S3.

x	0	1	2	3
$f(x)$	-2	0	3	4

S4.

t	-1	0	1	2
$f(t)$	0	2	7	-1

For each of the linear expressions in x in Exercises S7–S10, give the constant term and the coefficient of x .

S7. $3 - 2x + \frac{1}{2}$

S8. $4 - 3(x + 2) + 6(2x - 1)$

S9. $ax - ab - 3x + a + 3$

S10. $5(x - 1) + 3$

Exercises

In Exercises 1–3, which line has the greater

- (a) Slope? (b) y -intercept?

- $y = -1 + 2x$; $y = -2 + 3x$
- $y = 3 + 4x$; $y = 5 - 2x$
- $y = \frac{1}{4}x$; $y = 1 - 6x$

In Exercises 4–9, could the data represent a linear function? If so, give the rate of change.

- | | | | | |
|--------|----|----|----|----|
| x | 0 | 5 | 10 | 15 |
| $f(x)$ | 10 | 20 | 30 | 40 |
- | | | | | |
|--------|----|----|----|----|
| x | 0 | 10 | 20 | 30 |
| $h(x)$ | 20 | 40 | 50 | 55 |
- | | | | | |
|--------|----|-----|-----|-----|
| x | 0 | 100 | 300 | 600 |
| $g(x)$ | 50 | 100 | 150 | 200 |
- | | | | | | |
|--------|---|---|---|---|---|
| t | 1 | 2 | 3 | 4 | 5 |
| $g(t)$ | 5 | 4 | 5 | 4 | 5 |
- | | | | | |
|--------|----|----|----|----|
| x | -3 | -1 | 0 | 3 |
| $j(x)$ | 5 | 1 | -1 | -7 |

9.

γ	9	8	7	6	5
$p(\gamma)$	42	52	62	72	82

In Exercises 10–13, identify the vertical intercept and the slope, and explain their meanings in practical terms.

- The population of a town can be represented by the formula $P(t) = 54.25 - \frac{2}{7}t$, where $P(t)$ represents the population, in thousands, and t represents the time, in years, since 1970.
- A stalactite grows according to the formula $L(t) = 17.75 + \frac{1}{250}t$, where $L(t)$ represents the length of the stalactite, in inches, and t represents the time, in years, since the stalactite was first measured.
- The profit, in dollars, of selling n items is given by $P(n) = 0.98n - 3000$.
- A phone company charges according to the formula $C(n) = 29.99 + 0.05n$, where n is the number of minutes, and $C(n)$ is the monthly phone charge, in dollars.

Problems

- Table 1.25 shows the cost C , in dollars, of selling x cups of coffee per day from a cart.
 - Using the table, show that the relationship appears to be linear.
 - Plot the data in the table.
 - Find the slope of the line. Explain what this means in the context of the given situation.
 - Why should it cost \$50 to serve zero cups of coffee?

Table 1.25

x	0	5	10	50	100	200
C	50.00	51.25	52.50	62.50	75.00	100.00

- Table 1.26 gives the proposed fine $r = f(v)$ to be imposed on a motorist for speeding, where v is the motorist's speed and 55 mph is the speed limit.
 - Decide whether f appears to be linear.
 - What would the rate of change represent in practical terms for the motorist?
 - Plot the data points.

Table 1.26

v (mph)	60	65	70	75	80	85
r (dollars)	75	100	125	150	175	200

- In 2003, the number, N , of cases of SARS (Severe Acute Respiratory Syndrome) reported in Hong Kong¹⁵ was initially approximated by $N = 78.9 + 30.1t$, where t is the number of days since March 17. Interpret the constants 78.9 and 30.1.
- A new Toyota RAV4 costs \$23,500. The car's value depreciates linearly to \$18,823 in three years time.¹⁶ Write a formula which expresses its value, V , in terms of its age, t , in years.
- In 2012, the population of a town was 21,510 and growing by 63 people per year. Find a formula for P , the town's population, in terms of t , the number of years since 2012.
- A flight costs \$10,000 to operate, regardless of the number of passengers. Each ticket costs \$127. Express profit, π , as a linear function of the number of passengers, n , on the flight.

¹⁵World Health Organization, www.who.int/csr/sars/country/en, accessed September, 2005

¹⁶http://www.motortrend.com/used_cars/11/toyota/rav4/pricing/, accessed January 2013

20. Owners of an inactive quarry in Australia have decided to resume production. They estimate that it will cost them \$10,000 per month to maintain and insure their equipment and that monthly salaries will be \$30,000. It costs \$800 to mine a ton of rocks. Write a formula that expresses the total cost each month, c , as a function of r , the number of tons of rock mined per month.
21. In each case, graph a linear function with the given rate of change. Label and put scales on the axes.
- Increasing at 2.1 inches/day
 - Decreasing at 1.3 gallons/mile
22. A small café sells coffee for \$3.50 per cup. On average, it costs the café \$0.50 to make a cup of coffee (for grounds, hot water, filters). The café also has a fixed daily cost of \$450 (for rent, wages, utilities).
- Let R , C , and P be the café's daily revenue, costs, and profit, respectively, for selling x cups of coffee in a day. Find formulas for R , C , and P as functions of x . [Hint: The revenue, R , is the total amount of money that the café brings in. The cost, C , includes the fixed daily cost as well as the cost for all x cups of coffee sold. P is the café's profit after costs have been accounted for.]
 - Plot P against x . For what x -values is the graph of P below the x -axis? Above the x -axis? Interpret your results.
 - Interpret the slope and both intercepts of your graph in practical terms.
23. Table 1.27 gives the area and perimeter of a square as a function of the length of its side.
- From the table, decide if either area or perimeter could be a linear function of side length.
 - From the data make two graphs, one showing area as a function of side length, the other showing perimeter as a function of side length. Connect the points.
 - If you find a linear relationship, give its corresponding rate of change and interpret its significance.

Table 1.27

Length of side	0	1	2	3	4	5	6
Area of square	0	1	4	9	16	25	36
Perimeter of square	0	4	8	12	16	20	24

24. Make two tables, one comparing the radius of a circle to its area, the other comparing the radius of a circle to its circumference. Repeat parts (a), (b), and (c) from Problem 23, this time comparing radius with circumference, and radius with area.

¹⁷www.census.gov/ipc/www/idbsusum.html, accessed January 12, 2006.

¹⁸Hugo Beltrami of St. Francis Xavier University and David Chapman of the University of Utah posted this data at <http://geophysics.stfx.ca/public/borehole/borehole.html>, accessed November 10, 2005.

Table 1.28

Year	1950	1960	1970	1980	1990	2000
Population of country A	8.2	9.8	12.4	15.1	14.7	23.9
Population of country B	7.5	9.9	12.5	14.9	17.2	19.2

26. Table 1.29 gives the average temperature, T , at a depth d , in a borehole in Belleterre, Quebec.¹⁸ Evaluate $\Delta T/\Delta d$ on the following intervals, and explain what your answers tell you about borehole temperature.
- $25 \leq d \leq 150$
 - $25 \leq d \leq 75$
 - $100 \leq d \leq 200$

Table 1.29

d , depth (m)	25	50	75	100
T , temp ($^{\circ}\text{C}$)	5.50	5.20	5.10	5.10
d , depth (m)	125	150	175	200
T , temp ($^{\circ}\text{C}$)	5.30	5.50	5.75	6.00
d , depth (m)	225	250	275	300
T , temp ($^{\circ}\text{C}$)	6.25	6.50	6.75	7.00

27. Table ?? gives the temperature-depth profile, $T = f(d)$, in a borehole in Belleterre, Quebec, where T is the average temperature at a depth d .
- Could f be linear?
 - Graph f . What do you notice about the graph for $d \geq 150$?
 - What can you say about the average rate of change of f for $d \geq 150$?

28. A company finds that there is a linear relationship between the amount of money that it spends on advertising and the number of units it sells. If it spends no money on advertising, it sells 300 units. For each additional \$5000 spent, an additional 20 units are sold.
- If x is the amount of money that the company spends on advertising, find a formula for y , the number of units sold as a function of x .
 - How many units does the firm sell if it spends \$25,000 on advertising? \$50,000?
 - How much advertising money must be spent to sell 700 units?
 - What is the slope of the line you found in part (a)? Give an interpretation of the slope that relates units sold and advertising costs.
29. Tuition cost T (in dollars) for part-time students at Stonewall College is given by $T = 300 + 200C$, where C represents the number of credits taken.
- Find the tuition cost for eight credits.
 - How many credits were taken if the tuition was \$1700?
 - Make a table showing costs for taking from one to twelve credits. For each value of C , give both the tuition cost, T , and the cost per credit, T/C . Round to the nearest dollar.
 - Which of these values of C has the smallest cost per credit?
 - What does the 300 represent in the formula for T ?
 - What does the 200 represent in the formula for T ?
30. The summit of Africa's largest peak, Mt. Kilimanjaro, consists of the northern and southern ice fields and the Furtwangler glacier. An article in the Proceedings of the National Academy of Sciences¹⁹ indicates that in 2000 ($t = 0$) the area of the ice cover at the peak of Mt. Kilimanjaro was approximately 1951 m². By 2007, the area had shrunk to approximately 1555 m².
- If this decline is modeled by a linear function, find $A = f(t)$, the equation of the ice-cover area as a function of time. Explain what the slope and A -intercept mean in terms of the ice cover.
 - Evaluate $f(11)$.
- If this model is correct, when would you expect the ice cover to disappear?
31. When each of the following equations are written in the form $y = b + mx$, the result is $y = 5 + 4x$. Find the constants r, s, k, j in these equations.
- $y = 2r + x\sqrt{s}$
 - $y = \frac{1}{k} - (j - 1)x$.
32. Graph the following function in the window $-10 \leq x \leq 10, -10 \leq y \leq 10$. Is this graph a line? Explain.
- $$y = -x \left(\frac{x - 1000}{900} \right)$$
33. Graph $y = 2x + 400$ using the window $-10 \leq x \leq 10, -10 \leq y \leq 10$. Describe what happens, and how you can fix it by using a better window.
34. Graph $y = 200x + 4$ using the window $-10 \leq x \leq 10, -10 \leq y \leq 10$. Describe what happens and how you can fix it by using a better window.
35. Figure 1.28 shows the graph of $y = x^2/1000 + 5$ in the window $-10 \leq x \leq 10, -10 \leq y \leq 10$. Discuss whether this is a linear function.

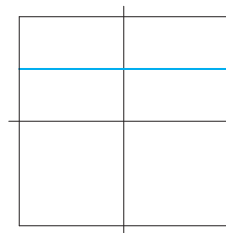

Figure 1.28

1.4 FORMULAS FOR LINEAR FUNCTIONS

To find a formula for a linear function we find values for the slope, m , and the vertical intercept, b , in the formula $y = b + mx$.

Finding a Formula for a Linear Function from a Table of Data

If a table of data represents a linear function, we first calculate m and then determine b .

¹⁹<http://www.pnas.org/content/early/2009/10/30/0906029106.full.pdf+html>, accessed November 27, 2009.

Example 1 A grapefruit is thrown into the air. Its velocity, v , is a linear function of t , the time since it was thrown. A positive velocity indicates the grapefruit is rising and a negative velocity indicates it is falling. Check that the data in Table 1.30 corresponds to a linear function. Find a formula for v in terms of t .

Table 1.30 Velocity of a grapefruit t seconds after being thrown into the air

t , time (sec)	1	2	3	4
v , velocity (ft/sec)	48	16	-16	-48

Solution Figure 1.29 shows the data in Table 1.30. The points appear to fall on a line. To check that the velocity function is linear, calculate the rates of change of v and see that they are constant. From time $t = 1$ to $t = 2$, we have

$$\text{Average rate of change of velocity with time} = \frac{\Delta v}{\Delta t} = \frac{16 - 48}{2 - 1} = -32.$$

For the next second, from $t = 2$ to $t = 3$, we have

$$\text{Average rate of change} = \frac{\Delta v}{\Delta t} = \frac{-16 - 16}{3 - 2} = -32.$$

You can check that the rate of change from $t = 3$ to $t = 4$ is also -32 .

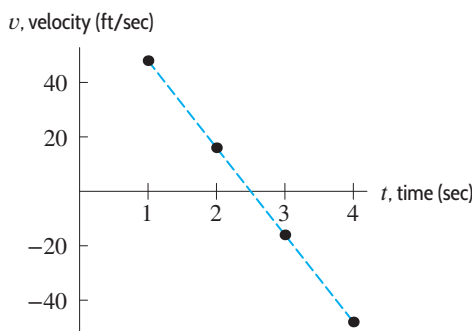

Figure 1.29: Velocity of a grapefruit is a linear function of time

A formula for v is of the form $v = b + mt$. Since m is the rate of change, we have $m = -32$ so $v = b - 32t$. The initial velocity (at $t = 0$) is represented by b . We are not given the value of v when $t = 0$, but we can use any data point to calculate b . For example, $v = 48$ when $t = 1$, so

$$48 = b - 32 \cdot 1,$$

which gives

$$b = 80.$$

Thus, a formula for the velocity is $v = 80 - 32t$.

What does the rate of change, m , in Example 1 tell us about the grapefruit? Think about the units:

$$m = \frac{\Delta v}{\Delta t} = \frac{\text{Change in velocity}}{\text{Change in time}} = \frac{-32 \text{ ft/sec}}{1 \text{ sec}} = -32 \text{ ft/sec per second.}$$

The value of m , -32 ft/sec per second, tells us that the grapefruit's velocity is decreasing by 32 ft/sec for every second that goes by. We say the grapefruit is accelerating at -32 ft/sec per second. (The units ft/sec per second are often written ft/sec^2 . Negative acceleration is also called deceleration.²⁰)

²⁰The notation ft/sec^2 is shorthand for ft/sec per second; it does not mean a "square second" in the same way that areas are measured in square feet or square meters.

Finding a Formula for a Linear Function from a Graph

We can calculate the slope, m , of a linear function using two points on its graph. Having found m , we can use either of the points to calculate b , the vertical intercept.

Example 2 Figure 1.30 shows oxygen consumption as a function of heart rate (that is, pulse) for two people.

- Assuming linearity, find formulas for these two functions.
- Interpret the slope of each graph in terms of oxygen consumption.

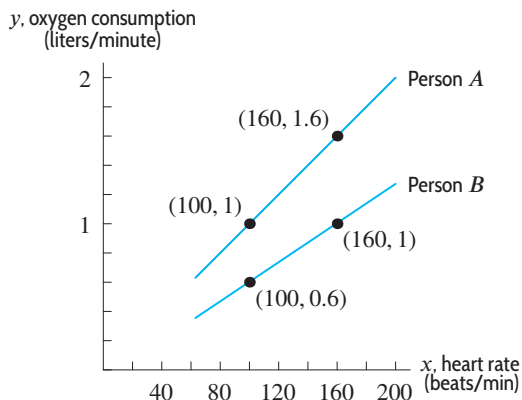

Figure 1.30: Oxygen consumption of two people running on treadmills

Solution (a) Let x be heart rate and let y be oxygen consumption. Since we are assuming linearity, $y = b + mx$. The two points on person A's line, $(100, 1)$ and $(160, 1.6)$, give

$$\text{Slope of A's line} = m = \frac{\Delta y}{\Delta x} = \frac{1.6 - 1}{160 - 100} = 0.01.$$

Thus $y = b + 0.01x$. To find b , use the fact that $y = 1$ when $x = 100$:

$$1 = b + 0.01(100)$$

$$1 = b + 1$$

$$b = 0,$$

so $y = 0.01x$. Alternatively, b can be found using the fact that $x = 160$ if $y = 1.6$.

For person B, we again begin with the formula $y = b + mx$. In Figure 1.30, two points on B's line are $(100, 0.6)$ and $(160, 1)$, so

$$\text{Slope of B's line} = m = \frac{\Delta y}{\Delta x} = \frac{1 - 0.6}{160 - 100} = \frac{0.4}{60} \approx 0.0067.$$

To find b , use the fact that $y = 1$ when $x = 160$:

$$1 = b + (0.4/60) \cdot 160$$

$$1 = b + 1.067$$

$$b = -0.067.$$

Thus, for person B, we have $y = -0.067 + 0.0067x$.

- (b) The slope for person A is $m = 0.01$, so

$$m = \frac{\text{Change in oxygen consumption}}{\text{Change in heart rate}} = \frac{\text{Change in liters/min}}{\text{Change in beats/min}} = 0.01 \frac{\text{liters}}{\text{heartbeat}}.$$

Every additional heartbeat (per minute) for person A translates to an additional 0.01 liters (per minute) of oxygen consumed.

The slope for person B is $m = 0.0067$. Thus, for every additional beat (per minute), person B consumes an additional 0.0067 liter of oxygen (per minute). Since the slope for person B is smaller than for person A , person B consumes less additional oxygen than person A for the same increase in pulse.

What do the y -intercepts of the functions in Example 2 say about oxygen consumption? Often the y -intercept of a function is a starting value. In this case, the y -intercept would be the oxygen consumption of a person whose pulse is zero (i.e. $x = 0$). Since a person running on a treadmill must have a pulse, in this case it makes no sense to interpret the y -intercept this way. The formula for oxygen consumption is useful only for realistic values of the pulse.

Finding a Formula for a Linear Function from a Verbal Description

Sometimes the verbal description of a linear function is less straightforward than those we saw in Section 1.3. Consider the following example.

Example 3 We have \$48 to spend on soda and chips for a party. A six-pack of soda costs \$6 and a bag of chips costs \$4. The number of six-packs we can afford, y , is a function of the number of bags of chips we decide to buy, x .

- Find an equation relating x and y .
- Graph the equation. Interpret the intercepts and the slope in the context of the party.

Solution (a) If we spend all \$48 on soda and chips, then we have the following equation:

$$\text{Amount spent on chips} + \text{Amount spent on soda} = \$48.$$

If we buy x bags of chips at \$4 per bag, then the amount spent on chips is $4x$. Similarly, if we buy y six-packs of soda at \$6 per six-pack, then the amount spent on soda is $6y$. Thus,

$$4x + 6y = 48.$$

We can solve for y , giving

$$6y = 48 - 4x$$

$$y = 8 - \frac{2}{3}x.$$

This is a linear function with slope $m = -2/3$ and y -intercept $b = 8$.

- The graph of this function is a discrete set of points, since the number of bags of chips and the number of six-packs of soda must be (nonnegative) integers.

To find the y -intercept, we set $x = 0$, giving

$$4 \cdot 0 + 6y = 48.$$

So $6y = 48$, giving $y = 8$.

Substituting $y = 0$ gives the x -intercept,

$$4x + 6 \cdot 0 = 48.$$

So $4x = 48$, giving $x = 12$. Thus the points $(0, 8)$ and $(12, 0)$ are on the graph.

The point $(0, 8)$ indicates that we can buy 8 six-packs of soda if we buy no chips. The point $(12, 0)$ indicates that we can buy 12 bags of chips if we buy no soda. The other points on the line describe affordable options between these two extremes. For example, the point $(6, 4)$ is on the line, because

$$4 \cdot 6 + 6 \cdot 4 = 48.$$

This means that if we buy 6 bags of chips, we can afford 4 six-packs of soda.

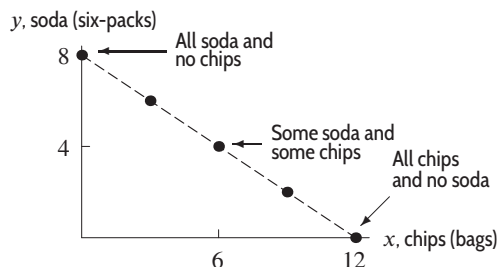

Figure 1.31: Relation between the number of six-packs, y , and the number of bags of chips, x

The points marked in Figure 1.31 represent affordable options. All affordable options lie on or below the line $4x + 6y = 48$. Not all points on the line are affordable options. For example, suppose we purchase one six-pack of soda for \$6. That leaves \$42 to spend on chips, meaning we would have to buy 10.5 bags of chips, which is not possible. Therefore, the point $(10.5, 1)$ is not an option, although it is a point on the line $4x + 6y = 48$.

To interpret the slope, notice that

$$m = \frac{\Delta y}{\Delta x} = \frac{\text{Change in number of six-packs}}{\text{Change in number of bags of chips}},$$

so the units of m are six-packs of soda per bags of chips. The fact that $m = -2/3$ means that for each additional 3 bags of chips purchased, we can purchase 2 fewer six-packs of soda. This occurs because 2 six-packs cost \$12, the same as 3 bags of chips. Thus, $m = -2/3$ is the rate at which the amount of soda we can buy decreases as we buy more chips.

Alternative Forms for the Equation of a Line

In Example 3, the equation $2x + 3y = 24$ represents a linear relationship between x and y even though the equation is not in the form $y = b + mx$. The following equations represent lines.

- The *slope-intercept form* is
 $y = b + mx$ where m is the slope and b is the y -intercept.
- The *point-slope form* is
 $y - y_0 = m(x - x_0)$ where m is the slope and (x_0, y_0) is a point on the line.
- The *standard form* is
 $Ax + By + C = 0$ where A , B , and C are constants.

If we know the slope of a line and the coordinates of a point on the line, it is often convenient to use the point-slope form of the equation.

Example 4 Use the point-slope form to find the equation of the line for the oxygen consumption of person A in Example 2.

Solution In Example 2, we found the slope of person A 's line to be $m = 0.01$. Since the point $(100, 1)$ lies on the line, the point-slope form gives the equation

$$y - 1 = 0.01(x - 100).$$

To check that this gives the same equation we got in Example 2, we multiply out and simplify:

$$\begin{aligned} y - 1 &= 0.01x - 1 \\ y &= 0.01x. \end{aligned}$$

Alternatively, we could have used the point $(160, 1.6)$ instead of $(100, 1)$, giving

$$y - 1.6 = 0.01(x - 160).$$

Multiplying out again gives $y = 0.01x$.

Equations of Horizontal and Vertical Lines

The slope m of a line $y = b + mx$ gives the rate of change of y with respect to x . What about a line with slope $m = 0$? If the rate of change of a quantity is zero, then the quantity does not change. Thus, if the slope of a line is zero, the value of y must be constant. Such a line is horizontal.

Example 5 Explain why the equation $y = 4$ represents a horizontal line and the equation $x = 4$ represents a vertical line.

Solution The equation $y = 4$ represents a linear function with slope $m = 0$. To see this, notice that this equation can be rewritten as $y = 4 + 0 \cdot x$. Thus, the value of y is 4 no matter what the value of x is. See Figure 1.32. Similarly, the equation $x = 4$ means that x is 4 no matter what the value of y is. Every point on the line in Figure 1.33 has x equal to 4, so this line is the graph of $x = 4$.

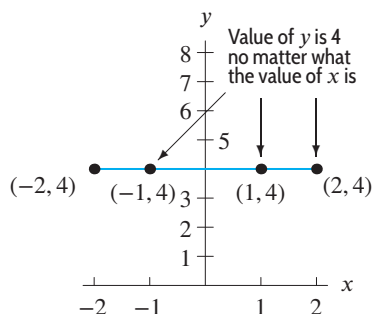

Figure 1.32: The horizontal line $y = 4$ has slope 0

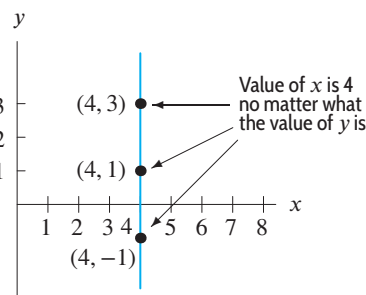

Figure 1.33: The vertical line $x = 4$ has an undefined slope

What is the slope of a vertical line? Figure 1.33 shows three points, $(4, -1)$, $(4, 1)$, and $(4, 3)$ on a vertical line. Calculating the slope, gives

$$m = \frac{\Delta y}{\Delta x} = \frac{3 - 1}{4 - 4} = \frac{2}{0}.$$

The slope is undefined because the denominator, Δx , is 0. The slope of every vertical line is undefined for the same reason. All the x -values on such a line are equal, so Δx is 0, and the denominator of the expression for the slope is 0. A vertical line is not the graph of a function, since it fails the vertical line test. It does not have an equation of the form $y = b + mx$.

In summary,

For any constant k :

- The graph of the equation $y = k$ is a horizontal line and its slope is zero.
- The graph of the equation $x = k$ is a vertical line and its slope is undefined.

Slopes of Parallel and Perpendicular Lines

Figure 1.34 shows two parallel lines. These lines are parallel because they have equal slopes.

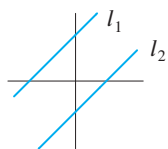

Figure 1.34: Parallel lines: l_1 and l_2 have equal slopes

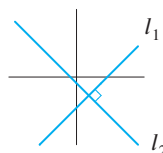

Figure 1.35: Perpendicular lines: Slopes of l_1 and l_2 are negative reciprocals of each other

What about perpendicular lines? Two perpendicular lines are graphed in Figure 1.35. We can see that if one line has a positive slope, then any perpendicular line must have a negative slope. In fact, we show that if l_1 and l_2 are two perpendicular lines with slopes, m_1 and m_2 , then m_1 is the negative reciprocal of m_2 . If m_1 and m_2 are not zero, we have the following result:

Let l_1 and l_2 be two lines having slopes m_1 and m_2 , respectively. Then:

- These lines are parallel if and only if $m_1 = m_2$.
- These lines are perpendicular if and only if $m_1 = -\frac{1}{m_2}$.

In addition, any two horizontal lines are parallel and $m_1 = m_2 = 0$. Any two vertical lines are parallel and m_1 and m_2 are undefined. A horizontal line is perpendicular to a vertical line. See Figures 1.36–1.38.

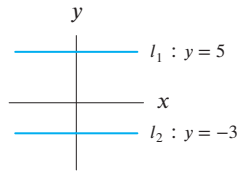

Figure 1.36: Any two horizontal lines are parallel

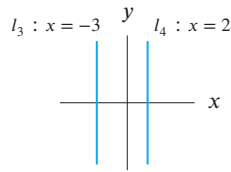

Figure 1.37: Any two vertical lines are parallel

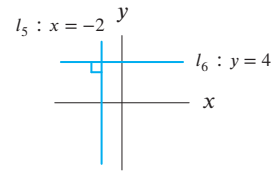

Figure 1.38: A horizontal line and a vertical line are perpendicular

Justification of Formula for Slopes of Perpendicular Lines

Figure 1.39 shows l_1 and l_2 , two perpendicular lines with slopes m_1 and m_2 . Neither line is horizontal or vertical, so m_1 and m_2 are both defined and nonzero. We will show that

$$m_2 = -\frac{1}{m_1}.$$

Using right triangle ΔPQR with side lengths a and b , we see that

$$m_1 = \frac{b}{a}.$$

Rotating ΔPQR by 90° about the point P produces triangle ΔPST . Using ΔPST , we see that

$$m_2 = -\frac{a}{b} = -\frac{1}{b/a} = -\frac{1}{m_1}.$$

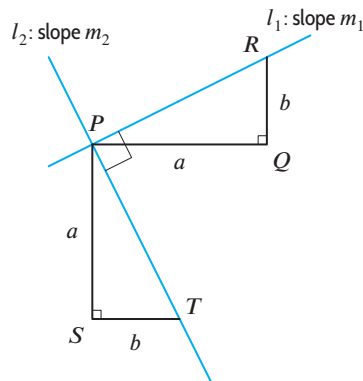

Figure 1.39: Perpendicular lines

Exercises and Problems for Section 1.4

Skill Refresher

Solve the equations in Exercises S1–S5.

- S1. $y - 5 = 21$
 S2. $2x - 5 = 13$
 S3. $2x - 5 = 4x - 9$
 S4. $17 - 28y = 13y + 24$
 S5. $\frac{5}{3}(y + 2) = \frac{1}{2} - y$

Exercises

Find formulas for the linear functions in Exercises 1–8.

- Slope -4 and x -intercept 7
- Slope 3 and y -intercept 8
- Passes through the points $(-1, 5)$ and $(2, -1)$
- Slope $2/3$ and passes through the point $(5, 7)$
- Has x -intercept 3 and y -intercept -5
- Slope 0.1 , passes through $(-0.1, 0.02)$
- Function f has $f(0.3) = 0.8$ and $f(0.8) = -0.4$
- Function f has $f(-2) = 7$ and $f(3) = -3$

Exercises 9–15 give data from a linear function. Find a formula for the function.

9.

Year, t	0	1	2
Value of computer, $\$V = f(t)$	2000	1500	1000

10.

Price per bottle, p (\$)	0.50	0.75	1.00
Number of bottles sold, $q = f(p)$	1500	1000	500

11.

Temperature, $y = f(x)$ ($^{\circ}\text{C}$)	0	5	20
Temperature, x ($^{\circ}\text{F}$)	32	41	68

12.

Temperature, $y = f(x)$, ($^{\circ}\text{R}$)	459.7	469.7	489.7
Temperature, x ($^{\circ}\text{F}$)	0	10	30



In Exercises S6–S10, solve for the indicated variable.

- S6. $I = Prt$, for P .
 S7. $C = \frac{5}{9}(F - 32)$, for F .
 S8. $C = 2\pi r$, for r .
 S9. $ab + ax = c - ax$, for x .
 S10. $by - d = ay + c$, for y .

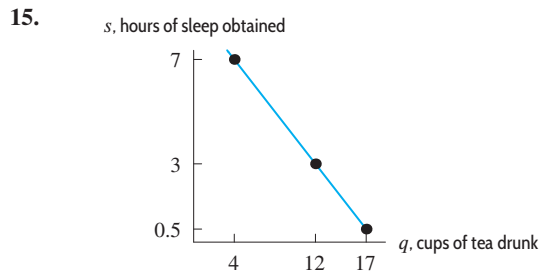
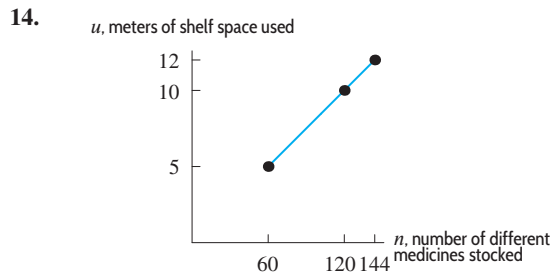

In Exercises 16–24, if possible rewrite the equation in slope-intercept form, $y = b + mx$.

16. $5(x + y) = 4$ 17. $3x + 5y = 20$
 18. $0.1y + x = 18$ 19. $5x - 3y + 2 = 0$
 20. $y - 0.7 = 5(x - 0.2)$ 21. $y = 5$
 22. $3x + 2y + 40 = x - y$ 23. $x = 4$
 24. $\frac{x + y}{7} = 3$

In Exercises 25–30, is the function linear? If so, rewrite it in slope-intercept form.

25. $g(w) = -\frac{1 - 12w}{3}$ 26. $F(P) = 13 - \frac{2^{-1}}{4}P$
 27. $j(s) = 3s^{-1} + 7$ 28. $C(r) = 2\pi r$
 29. $h(x) = 3^x + 12$ 30. $f(x) = m^2x + n^2$

In Exercises 31–36, are the lines perpendicular? Parallel? Neither?

31. $y = 5x - 7$; $y = 5x + 8$
 32. $y = 4x + 3$; $y = 13 - \frac{1}{4}x$

33. $y = 2x + 3$; $y = 2x - 7$
 34. $y = 4x + 7$; $y = \frac{1}{4}x - 2$
 35. $f(q) = 12q + 7$; $g(q) = \frac{1}{12}q + 96$
 36. $2y = 16 - x$; $4y = -8 - 2x$

Problems

Find formulas for the linear functions in Problems 37–40.

37. The graph of f contains $(-3, -8)$ and $(5, -20)$.
 38. $g(100) = 2000$ and $g(400) = 3800$
 39. $P = h(t)$ gives the size of a population that begins with 12,000 members and grows by 225 members each year.
 40. The graph of h intersects the graph of $y = x^2$ at $x = -2$ and $x = 3$.
 41. (a) By hand, graph $y = 3$ and $x = 3$.
 (b) Can the equations in part (a) be written in slope-intercept form?
 42. Find the equation of the line parallel to $3x + 5y = 6$ and passing through the point $(0, 6)$.
 43. Find the equation of the line passing through the point $(2, 1)$ and perpendicular to the line $y = 5x - 3$.
 44. Find the equations of the lines parallel to and perpendicular to the line $y + 4x = 7$, and through the point $(1, 5)$.
 45. In Table 1.31, data for two functions f and g are given. One of the functions is linear, and the other is not.
 (a) Which of the two functions is linear? Explain how you know.
 (b) Find the equation of the linear function. Write your answer in slope-intercept form.

Table 1.31

x	1	1.5	2	2.5	3
$f(x)$	-1.22	-0.64	-0.06	0.52	1.10
$g(x)$	9.71	4.86	2.43	1.22	0.61

46. Line l is given by $y = 3 - \frac{2}{3}x$ and point P has coordinates $(6, 5)$.
 (a) Find the equation of the line containing P and parallel to l .
 (b) Find the equation of the line containing P and perpendicular to l .
 (c) Graph the equations in parts (a) and (b).
 47. An empty champagne bottle is tossed from a hot-air balloon. Its upward velocity is measured every second and recorded in Table 1.32.
 (a) Describe the motion of the bottle in words. What do negative values of v represent?

- (b) Find a formula for v in terms of t .
 (c) Explain the physical significance of the slope of your formula.
 (d) Explain the physical significance of the t -axis and v -axis intercepts.

Table 1.32

t (sec)	0	1	2	3	4	5
v (ft/sec)	40	8	-24	-56	-88	-120

Table 1.33 gives the cost, $C(n)$, of producing a certain good as a linear function of n , the number of units produced. Use the table to answer Problems 48–50.

Table 1.33

n (units)	100	125	150	175
$C(n)$ (dollars)	11000	11125	11250	11375

48. Evaluate the following expressions. Give economic interpretations for each.
 (a) $C(175)$ (b) $C(175) - C(150)$
 (c) $\frac{C(175) - C(150)}{175 - 150}$
 49. Estimate $C(0)$. What is the economic significance of this value?
 50. The *fixed cost* of production is the cost incurred before any goods are produced. The *unit cost* is the cost of producing an additional unit. Find a formula for $C(n)$ in terms of n , given that
 Total cost = Fixed cost + Unit cost · Number of units
 51. John wants to buy a dozen rolls. The local bakery sells sesame and poppy-seed rolls for the same price.
 (a) Make a table of all the possible combinations of rolls if he buys a dozen, where s is the number of sesame seed rolls and p is the number of poppy-seed rolls.
 (b) Find a formula for p as a function of s .
 (c) Graph this function.

52. In a college meal plan you pay a membership fee; then all your meals are at a fixed price per meal.
- If 90 meals cost \$1005 and 140 meals cost \$1205, write a linear function that describes the cost of a meal plan, C , in terms of the number of meals, n .
 - What is the cost per meal and what is the membership fee?
 - Find the cost for 120 meals.
 - Find n in terms of C .
 - Use part (d) to determine the maximum number of meals you can buy on a budget of \$1285.

53. The solid waste generated each year in the cities of the US is increasing.²¹ The solid waste generated, in millions of tons, was 88.1 in 1960 and 249.9 in 2010. The trend appears linear during this time.

- Construct a formula for the amount of municipal solid waste generated in the US by finding the equation of the line through these two points.
- Use this formula to predict the amount of municipal solid waste generated in the US, in millions of tons, in the year 2020.

54. The demand for gasoline can be modeled as a linear function of price. If the price of gasoline is $p = \$3.10$ per gallon, the quantity demanded in a fixed period is $q = 65$ gallons. If the price rises to \$3.50 per gallon, the quantity demanded falls to 45 gallons in that period.

- Find a formula for q in terms of p .
- Explain the economic significance of the slope of your formula.
- Explain the economic significance of the q -axis and p -axis intercepts.

55. Find a formula for the linear function $h(t)$ whose graph intersects the graph of $j(t) = 30(0.2)^t$ at $t = -2$ and $t = 1$.

56. Find the equation of line l in Figure 1.40.

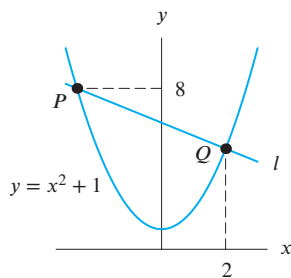

Figure 1.40

57. Find the equation of the line l , shown in Figure 1.41, if its slope is $m = 4$.

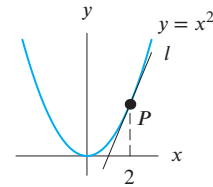

Figure 1.41

58. Find an equation for the line l in Figure 1.42 in terms of the constant A and values of the function f .

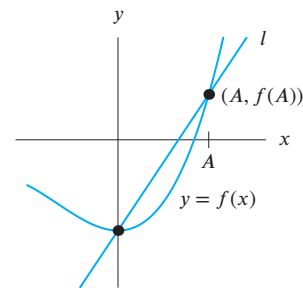

Figure 1.42

59. A dose-response function can be used to describe the increase in risk associated with the increase in exposure to various hazards. For example, the risk of contracting lung cancer depends, among other things, on the number of cigarettes a person smokes per day. This risk can be described by a linear dose-response function. For example, it is known that smoking 10 cigarettes per day increases a person's probability of contracting lung cancer by a factor of 25, while smoking 20 cigarettes a day increases the probability by a factor of 50.

- Find a formula for $i(x)$, the increase in the probability of contracting lung cancer for a person who smokes x cigarettes per day as compared to a non-smoker.
- Evaluate $i(0)$.
- Interpret the slope of the function i .

60. Wire is sold by gauge size, where the diameter of the wire is a decreasing linear function of gauge. Gauge 2 wire has a diameter of 0.2656 inches and gauge 8 wire has a diameter of 0.1719 inches. Find the diameter for wires of gauge 12.5 and gauge 0. What values of the gauge do not make sense in this model?

²¹http://www.epa.gov/osw/nonhaz/municipal/pubs/msw_2010_rev_factsheet.pdf, accessed January, 2013.

61. You can type four pages in 50 minutes and nine pages in an hour and forty minutes.
- Find a linear function for the number of pages typed, p , as a function of time, t . If time is measured in minutes, what values of t make sense in this example?
 - How many pages can be typed in two hours?
 - Interpret the slope of the function in practical terms.
 - Use the result in part (a) to solve for time as a function of the number of pages typed.
 - How long does it take to type a 15-page paper?
 - Write a short paragraph explaining why it is useful to know both of the formulas obtained in part (a) and part (d).

In Problems 62–63, write the functions in slope-intercept form. Identify the values of b and m .

62. $v(s) = \pi x^2 - 3xr - 4rs - s\sqrt{x}$

63. $w(r) = \pi x^2 - 3xr - 4rs - s\sqrt{x}$

64. The development time, t , of an organism is the number of days required for the organism to mature, and the development rate is defined as $r = 1/t$. In cold-blooded organisms such as insects, the development rate depends on temperature: the colder it is, the longer the organism takes to develop. For such organisms, the degree-day model²² assumes that the development rate r is a linear function of temperature H (in °C):

$$r = b + kH.$$

- According to the degree-day model, there is a minimum temperature H_{\min} below which an organism never matures. Find a formula for H_{\min} in terms of the constants b and k .
- Define S as $S = (H - H_{\min})t$, where S is the number of degree-days. That is, S is the number of days t times the number of degrees between H and H_{\min} . Use the formula for r to show that S is a constant. In other words, find a formula for S that does not involve H . Your formula will involve k .
- A certain organism requires $t = 25$ days to develop at a constant temperature of $H = 20^\circ\text{C}$ and has

$H_{\min} = 15^\circ\text{C}$. Using the fact that S is a constant, how many days does it take for this organism to develop at a temperature of 25°C ?

- In part (c) we assumed that the temperature H is constant throughout development. If the temperature varies from day to day, the number of degree-days can be accumulated until they total S , at which point the organism completes development. For instance, suppose on the first day the temperature is $H = 20^\circ\text{C}$ and that on the next day it is $H = 22^\circ\text{C}$. Then for these first two days

Total number of degree days

$$= (20 - 15) \cdot 1 + (22 - 15) \cdot 1 = 12.$$

Based on Table 1.34, on what day does the organism reach maturity?

Table 1.34

Day	1	2	3	4	5	6	7	8	9	10	11	12
H (°C)	20	22	27	28	27	31	29	30	28	25	24	26

- (Continuation of Problem 64.) Table 1.35 gives the development time t (in days) for an insect as a function of temperature H (in °C).
- Find a linear formula for r , the development rate, in terms of H .
- Find the value of S , the number of degree-days required for the organism to mature.

Table 1.35

H , °C	20	22	24	26	28	30
t , days	14.3	12.5	11.1	10.0	9.1	8.3

1.5 MODELING WITH LINEAR FUNCTIONS

Interpreting the Parameters of a Linear Function

The slope-intercept form for a linear function is $y = b + mx$, where b is the y -intercept and m is the slope. The parameters b and m can be used to compare linear functions.

²²Information drawn from a web site created by Dr. Alexei A. Sharov at the Virginia Polytechnic Institute, <http://www.ento.vt.edu/sharov/PopEcol/popecol.html>, accessed September 2002.

Example 1 With time, t , in years, the populations of four towns, P_A , P_B , P_C and P_D , are given by the following formulas:

$$P_A = 20,000 + 1600t, \quad P_B = 50,000 - 300t, \quad P_C = 650t + 45,000, \quad P_D = 15,000(1.07)^t.$$

- (a) Which populations are represented by linear functions?
 (b) Describe in words what each linear model tells you about that town's population. Of the towns that grow linearly, which town starts out with the most people? Which is growing fastest?

Solution

- (a) The populations of towns A , B , and C are represented by linear functions because they are written in the form $P = b + mt$. Town D 's population does not grow linearly since its formula, $P_D = 15,000(1.07)^t$, cannot be expressed in the form $P_D = b + mt$.
 (b) For town A , we have

$$P_A = \underbrace{20,000}_b + \underbrace{1600}_m \cdot t,$$

so $b = 20,000$ and $m = 1600$. This means that in year $t = 0$, town A has 20,000 people. It grows by 1600 people per year.

For town B , we have

$$P_B = \underbrace{50,000}_b + \underbrace{(-300)}_m \cdot t,$$

so $b = 50,000$ and $m = -300$. This means that town B starts with 50,000 people. The negative slope indicates that the population is decreasing at the rate of 300 people per year.

For town C , we have

$$P_C = \underbrace{45,000}_b + \underbrace{650}_m \cdot t,$$

so $b = 45,000$ and $m = 650$. This means that town C begins with 45,000 people and grows by 650 people per year.

Town B starts out with the most people, 50,000, but town A , with a rate of change of 1600 people per year, grows the fastest of the three towns that grow linearly.

The Effect of the Parameters on the Graph of a Linear Function

The graph of a linear function is a line. Changing the values of b and m gives different members of the family of linear functions. In summary:

Let $y = b + mx$. Then the graph of y against x is a line.

- The y -intercept, b , tells us where the line crosses the y -axis.
- If the slope, m , is positive, the line climbs from left to right. If the slope, m , is negative, the line falls from left to right.
- The slope, m , tells us how fast the line is climbing or falling.
- The larger the magnitude of m (either positive or negative), the steeper the graph of f .

- Example 2**
- Graph the three linear functions P_A , P_B , P_C from Example 1 and show how to identify the values of b and m from the graph.
 - Graph P_D from Example 1 and explain how the graph shows P_D is not a linear function.

Solution (a) Figure 1.43 gives graphs of the three functions:

$$P_A = 20,000 + 1600t, \quad P_B = 50,000 - 300t, \quad \text{and} \quad P_C = 45,000 + 650t.$$

The values of b identified in Example 1 tell us the vertical intercepts. Figure 1.43 shows that the graph of P_A crosses the P -axis at $P = 20,000$, the graph of P_B crosses at $P = 50,000$, and the graph of P_C crosses at $P = 45,000$.

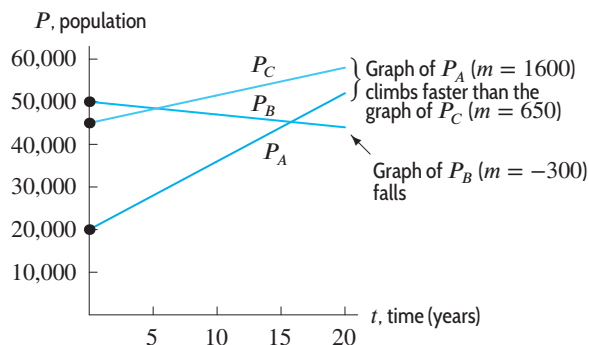

Figure 1.43: Graphs of three linear functions, P_A , P_B , and P_C , showing starting values and rates of climb

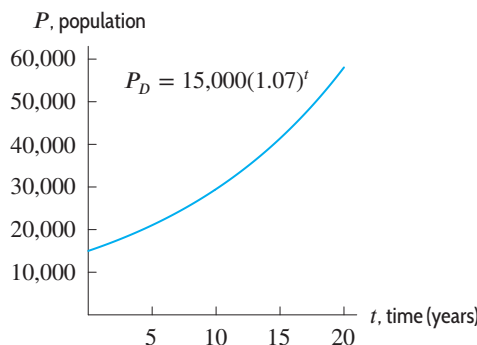

Figure 1.44: Graph of $P_D = 15,000(1.07)^t$ is not a line

Notice that the graphs of P_A and P_C are both climbing and that P_A climbs faster than P_C . This corresponds to the fact that the slopes of these two functions are positive ($m = 1600$ for P_A and $m = 650$ for P_C) and the slope of P_A is larger than the slope of P_C .

The graph of P_B falls when read from left to right, indicating that population decreases over time. This corresponds to the fact that the slope of P_C is negative ($m = -300$).

- (b) Figure 1.44 gives a graph of P_D . Since it is not a line, P_D is not a linear function.

Intersection of Two Lines

The point (x, y) at which two lines intersect satisfies the equations for both lines. Thus, to find this point, we solve the equations simultaneously.²³ When modeling real phenomena, the point of intersection often has a practical meaning.

- Example 3** The cost, in dollars, of renting a car for a day from three different rental agencies and driving it d miles is given by the following functions:

$$C_1 = 0.50d, \quad C_2 = 30 + 0.20d, \quad C_3 = 50 + 0.10d.$$

- For each agency, describe the rental agreement in words and graph the cost function. Use one set of axes for all three functions.
- For what driving distance does Agency 1 cost the same as Agency 2? If you drive 50 miles or less, which agency is cheapest?
- How do you determine which agency provides the cheapest car rental for any given driving distance?

²³The algebra in this section is reviewed in the Skills Refresher on page 62.

- Solution (a) See Figure 1.45. Agency 1 charges \$50 plus \$0.10 per mile driven. Agency 2 charges \$30 plus \$0.20 per mile. Agency 3 charges \$0.50 per mile driven.

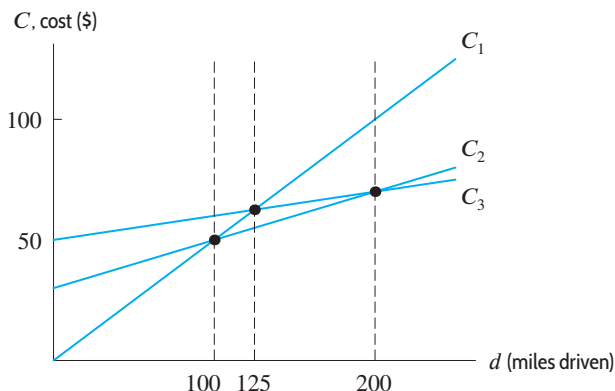

Figure 1.45: Cost of driving a car d miles when renting from three different agencies

- (b) The costs for Agency 1 and Agency 2 are equal when the graphs of their cost functions intersect. To find the intersection point, we set the cost functions equal, $C_1 = C_2$, and solve for d :

$$\begin{aligned} 0.50d &= 30 + 0.20d \\ 0.50d - 0.20d &= 30 \\ 0.30d &= 30 \\ d &= 100. \end{aligned}$$

So, if we drive 100 miles, the rental cost is the same for Agency 1 and Agency 2, as Figure 1.45 shows.

Figure 1.45 also shows that the graph of C_1 is below the graph of C_2 for $d < 100$. This means that it is cheaper to rent from Agency 1 than from Agency 2 if we drive less than 100 miles. For $d < 100$, the graph of C_1 is also below the graph of C_3 , so renting from Agency 1 is the cheapest option if we drive 50 miles or less.

- (c) Which agency is cheapest depends on how far we drive. If we are not driving far, Agency 1 may be cheapest because it only charges for miles driven and has no other fees. If we want to drive a long way, Agency 3 may be cheapest (even though it charges \$50 up front) because it has the lowest per-mile rate.

Figure 1.45 and part (b) show that for d up to 100 miles, Agency 1 costs the least.

For d between 100 and about 200 miles, Figure 1.45 suggests the values of C_2 are less than the values of C_1 and C_3 . To find the exact value of d where C_2 and C_3 intersect, we solve the equation $C_2 = C_3$:

$$\begin{aligned} 30 + 0.20d &= 50 + 0.10d \\ 0.10d &= 20 \\ d &= 200. \end{aligned}$$

Thus Agency 2 is cheapest when we drive between 100 and 200 miles.

For d more than 200 miles, the values of C_3 are less than the values of C_1 and C_2 , meaning Agency 3 is cheapest for large distances—as expected since C_3 has the lowest per-mile rate.

Notice that the point where C_1 and C_3 intersect is not important for deciding which agency is the cheapest: C_2 still has the lowest cost value where C_1 and C_3 intersect.

Linear Inequalities in Two Variables

We now see how to solve problems using linear inequalities rather than linear equations.²⁴

Example 4 The temperature at the base of a mountain is 90°F and drops by 5°F for every thousand-foot increase in elevation. On what part of the mountain is the temperature cooler than 40°F?

Solution Since the temperature, T , drops at a constant rate as the elevation, h , increases, if T is in degrees Fahrenheit and h is in thousands of feet from the base of the mountain, we have

$$T = 90 - 5h.$$

We want to know for what values of h we have $90 - 5h < 40$.

One way to solve the inequality is to subtract 40 from each side of the inequality to obtain

$$50 - 5h < 0,$$

and then add $5h$ to each side to get

$$50 < 5h.$$

Dividing each side by 5 gives

$$10 < h.$$

This means that the temperature is below 40° at any point more than 10,000 feet above the base of the mountain.

A second approach is to subtract 90 from each side of $90 - 5h < 40$ to get

$$-5h < -50.$$

At this point, we divide each side of the inequality by -5 . Since -5 is negative, this division switches the direction of the inequality, giving

$$h > 10.$$

Note that if we forget to switch the direction of the inequality, we get the incorrect solution $h < 10$, suggesting that the temperature is cooler than 40°F below the 10,000-foot line. However, the temperature is cooler near the top of the mountain, not near the bottom.

Example 5 When people consume more calories than required, they gain weight; when they consume fewer calories than required, they lose weight. For an active 20-year-old, six-foot-tall man weighing w pounds, the Harris-Benedict equation²⁵ states that the number of calories, C , needed daily to maintain weight is $C = 1321 + 9.44w$.

(a) The points satisfying $C = 1321 + 9.44w$ lie on a line. If the w -axis is horizontal, the points satisfying

$$C > 1321 + 9.44w \quad \text{or} \quad C < 1321 + 9.44w$$

lie above or below the line. Which of these two inequalities does the point $w = 170$, $C = 3500$ satisfy? Is the point above or below the line? How about the point $w = 200$, $C = 3000$?

- (b) Explain what your answers to part (a) mean in the context of weight and caloric intake.
 (c) Graph the set of all points that satisfy the inequality $C < 1321 + 9.44w$. What does this region represent in terms of calories and weight?
 (d) Sketch the region where $C \leq 3000$ and $C > 1321 + 9.44w$. What does this region represent in terms of calories and weight?

²⁴Methods for solving linear inequalities are included in the Skills Refresher on page 62.

²⁵*The Harris Benedict equation reevaluated.* A.M. Roza and H.M. Shizgal. American Journal of Clinical Nutrition. Vol. 40, No. 1 (July 1984): 168-182.

Solution (a) To determine which inequality is satisfied, we substitute the value of w into the expression $1321 + 9.44w$ and compare the result with the value of C .

If $w = 170$, $C = 3500$, substituting w gives $1321 + 9.44 \cdot 170 = 2925.8$. Since $C > 2925.8$, we have

$$C > 1321 + 9.44w. \quad \text{Thus, the point } (170, 3500) \text{ is above the line.}$$

If $w = 200$, $C = 3000$, substituting w gives $1321 + 9.44 \cdot 200 = 3209$. Since $C < 3209$, we have

$$C < 1321 + 9.44w. \quad \text{Thus, the point } (200, 3000) \text{ is below the line.}$$

(b) A man weighing 170 pounds who eats 3500 calories per day is eating more calories than needed, so he will gain weight. On the other hand, a man weighing 200 pounds who eats 3000 calories daily will lose weight, because he is eating fewer calories than needed.

(c) Figure 1.46 shows the line $C = 1321 + 9.44w$, the point $(170, 3500)$ above the line and the point $(200, 3000)$ below the line.

The points satisfying $C < 1321 + 9.44w$ are those whose C -coordinates are lower than $1321 + 9.44w$; that is, all the points below the line. The region represents all of the combinations of weights and caloric intakes at which an active, 6-foot-tall, 20 year-old man loses weight.

Note that the line itself is not included in the region, since on this line C is equal to, not less than, $1321 + 9.44w$. We use a dashed line to indicate this.

(d) The region, shaded in Figure 1.47, shows the combinations of weights and calories—up to 3000 calories—for which an active 6-foot, 20 year-old man gains weight.

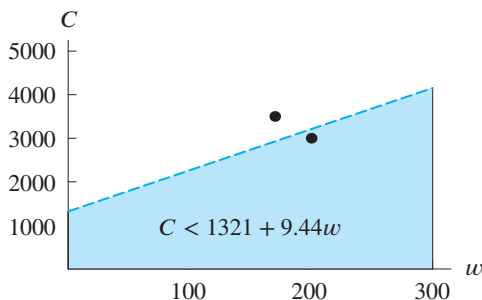

Figure 1.46: Shaded region is solution to $C < 1321 + 9.44w$

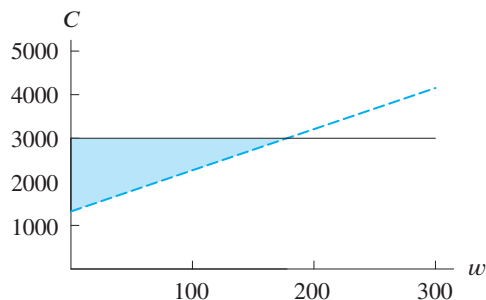

Figure 1.47: Shaded region is $C \leq 3000$ and $C < 1321 + 9.44w$

Exercises and Problems for Section 1.5

Skill Refresher

In Exercises S1–S6, solve the equations simultaneously if possible.

S1.
$$\begin{cases} x + y = 3 \\ y = 5 \end{cases}$$

S2.
$$\begin{cases} x + y = 3 \\ x - y = 5 \end{cases}$$

S3.
$$\begin{cases} x + y = 2 \\ 2x + 2y = 7 \end{cases}$$

S4.
$$\begin{cases} y = x - 3 \\ 2y - 2x = -6 \end{cases}$$

S5.
$$\begin{cases} 2x - y = 10 \\ x + 2y = 15 \end{cases}$$

S6.
$$\begin{cases} 2(x + y) = 3 \\ x = y + 3(x - 5) \end{cases}$$

Determine the points of intersection for Exercises S7–S8.

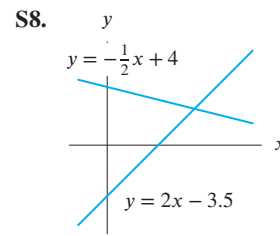
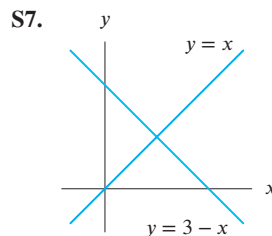

Exercises

1. Without using a calculator, match the equations (a) – (f) to the graphs (I) – (VI).

- (a) $y = -2.72x$ (b) $y = 0.01 + 0.001x$
- (c) $y = 27.9 - 0.1x$ (d) $y = 0.1x - 27.9$
- (e) $y = -5.7 - 200x$ (f) $y = x/3.14$

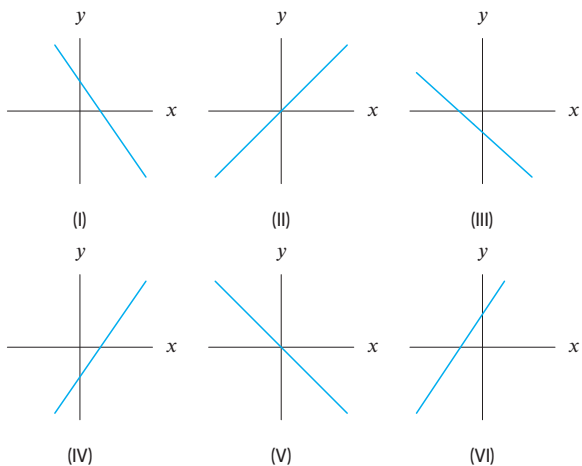

2. Without a calculator, match the equations (a)–(g) to the graphs (I)–(VII).

- (a) $y = x - 5$ (b) $-3x + 4 = y$
- (c) $5 = y$ (d) $y = -4x - 5$
- (e) $y = x + 6$ (f) $y = x/2$
- (g) $5 = x$

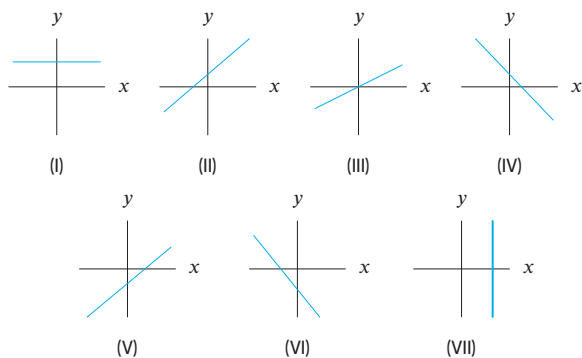

3. Figure 1.48 gives lines A, B, C, D, and E. Without a calculator, match each line to f, g, h, u or v:

- $f(x) = 20 + 2x$
- $g(x) = 20 + 4x$
- $h(x) = 2x - 30$
- $u(x) = 60 - x$
- $v(x) = 60 - 2x$

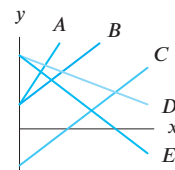

Figure 1.48

4. Without a calculator, match the following functions to the lines in Figure 1.49:

- $f(x) = 5 + 2x$
- $g(x) = -5 + 2x$
- $h(x) = 5 + 3x$
- $j(x) = 5 - 2x$
- $k(x) = 5 - 3x$

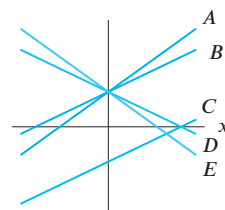
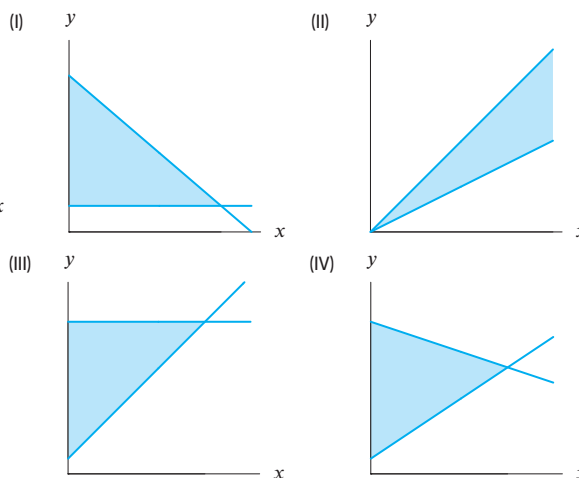

Figure 1.49

5. Without a calculator, match the systems of inequalities (a)–(d) to the graphs (I)–(IV). Give reasons.

- (a) $y \geq x$ and $y \leq 2x$ (b) $y \geq 1+2x$ and $y \leq 10-x$
- (c) $y \geq 2$ and $y \leq 12-2x$ (d) $y \geq 3x+1$ and $y \leq 10$



Problems

- 6. Sketch five different functions in the family $y = -2 - ax$ for $a < 0$.
- 7. Estimate the slope of the line in Figure 1.50 and find an approximate equation for the line.

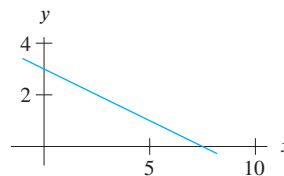

Figure 1.50

8. Find the equation of the line l_2 in Figure 1.52.

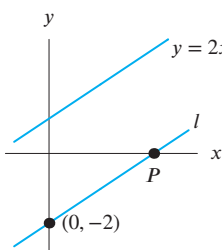

Figure 1.51

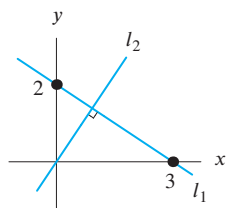

Figure 1.52

9. Line l in Figure 1.51 is parallel to the line $y = 2x + 1$. Find the coordinates of the point P .
10. The cost of a Frigbox refrigerator is \$950, and it depreciates \$50 each year. The cost of an Arctic Air refrigerator is \$1200, and it depreciates \$100 per year.
- If a Frigbox and an Arctic Air are bought at the same time, when do the two refrigerators have equal value?
 - If both refrigerators continue to depreciate at the same rates, what happens to the values of the refrigerators in 20 years' time? What does this mean?
11. You need to rent a car and compare the charges of three different companies. Company A charges 20 cents per mile plus \$20 per day. Company B charges 10 cents per mile plus \$35 per day. Company C charges \$70 per day with no mileage charge.
- Find formulas for the cost of driving cars rented from companies A , B , and C , in terms of x , the distance driven in miles in one day.
 - Graph the costs for each company for $0 \leq x \leq 500$. Put all three graphs on the same set of axes.
 - What do the slope and the vertical intercept tell you in this situation?
 - Use the graph in part (b) to find under what circumstances company A is the cheapest. What about Company B ? Company C ? Explain why your results make sense.

Solve Problems 12–15 by setting up a linear inequality.

12. A dog requires 1300 calories per day. A cup of dry dog food has 350 calories. The dog has already eaten a can of wet food, containing 400 calories. How many cups of dry food, n , can it eat before exceeding its daily caloric limit?
13. Blood alcohol concentration (BAC) is often used as a measure of intoxication.²⁶ For a 180-pound man, the BAC increases linearly by 0.02% for every drink taken in a one-hour period. If at the start of the hour he has a BAC of $B = 0.01\%$, how many drinks, n , can he have during the hour while remaining below the legal limit of 0.08%?

²⁶http://en.wikipedia.org/wiki/Blood_alcohol_content#cite_ref-4, accessed February 8, 2013.

²⁷http://en.wikipedia.org/wiki/Blood_alcohol_content#cite_ref-4, accessed February 8, 2013.

14. For a 180-pound man, blood alcohol concentration (BAC) decreases linearly by 0.015% every hour if he does not consume any further drinks.²⁷ If at the start of the hour he has a BAC of $B = 0.13\%$, how many hours, t , must he wait before his BAC falls below the legal limit of 0.08%?

15. A car's fuel economy is 30 mpg. A warning light is displayed if the remaining distance that can be driven before the car runs out of gas drops below 50 miles. Initially the car has 10 gallons of gas. How many gallons, g , can be used before the warning light comes on?

16. Broadway Cabs and City Cars are two competing taxi companies in a small town. The cost in dollars of a cab ride of d miles is $C_1 = 2.5 + 2.6d$ for Broadway Cabs and $C_2 = 4 + 2.45d$ for City Cars.

- Describe in words the fare breakdown for each company.
- Determine the conditions under which Broadway Cabs is cheaper than City Cars.
- You need a ride to the airport, which is 12 miles from your house. To get the lowest fare, which company should you call and how much will it cost?

17. Assume A , B , C are constants with $A \neq 0$, $B \neq 0$. Consider the equation

$$Ax + By = C.$$

- Show that $y = f(x)$ is linear. State the slope and the x - and y -intercepts of $f(x)$.
- Graph $y = f(x)$, labeling the x - and y -intercepts in terms of A , B , and C , assuming

(i) $A > 0, B > 0, C > 0$

(ii) $A > 0, B > 0, C < 0$

(iii) $A > 0, B < 0, C > 0$

18. Fill in the missing coordinates for the points in the following figures.

- The triangle in Figure 1.53.
- The parallelogram in Figure 1.54.

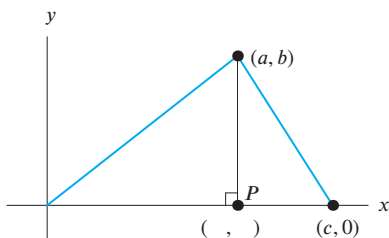

Figure 1.53

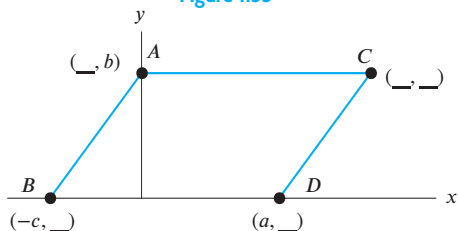

Figure 1.54

19. Fill in the missing coordinates in Figure 1.55. Write an equation for the line connecting the two points.

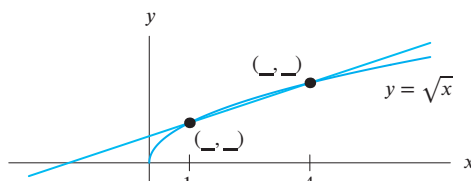

Figure 1.55

20. Using the window $-10 \leq x \leq 10$, $-10 \leq y \leq 10$, graph $y = x$, $y = 10x$, $y = 100x$, and $y = 1000x$.
- Explain what happens to the graphs of the lines as the slopes become large.
 - Write an equation of a line that passes through the origin and is horizontal.
21. Graph $y = x + 1$, $y = x + 10$, and $y = x + 100$ in the window $-10 \leq x \leq 10$, $-10 \leq y \leq 10$.
- Explain what happens to the graph of a line, $y = b + mx$, as b becomes large.
 - Write a linear equation whose graph cannot be seen in the window $-10 \leq x \leq 10$, $-10 \leq y \leq 10$ because all its y -values are less than the y -values shown.
22. The graphical interpretation of the slope is that it shows steepness. Using a calculator or a computer, graph the function $y = 2x - 3$ in the following windows:
- $-10 \leq x \leq 10$ by $-10 \leq y \leq 10$

- $-10 \leq x \leq 10$ by $-100 \leq y \leq 100$
- $-10 \leq x \leq 10$ by $-1000 \leq y \leq 1000$
- Write a sentence about how steepness is related to the window being used.

23. A circle of radius 2 is centered at the origin and goes through the point $(-1, \sqrt{3})$.
- Find an equation for the line through the origin and the point $(-1, \sqrt{3})$.
 - Find an equation for the tangent line to the circle at $(-1, \sqrt{3})$. [Hint: A tangent line is perpendicular to the radius at the point of tangency.]
24. Find an equation for the altitude through point A of the triangle ABC , where A is $(-4, 5)$, B is $(-3, 2)$, and C is $(9, 8)$. [Hint: The altitude of a triangle is perpendicular to the base.]
25. Two lines are given by $y = b_1 + m_1x$ and $y = b_2 + m_2x$, where b_1 , b_2 , m_1 , and m_2 are constants.
- What conditions are imposed on b_1 , b_2 , m_1 , and m_2 if the two lines have no points in common?
 - What conditions are imposed on b_1 , b_2 , m_1 , and m_2 if the two lines have all points in common?
 - What conditions are imposed on b_1 , b_2 , m_1 , and m_2 if the two lines have exactly one point in common?
 - What conditions are imposed on b_1 , b_2 , m_1 , and m_2 if the two lines have exactly two points in common?

In Problems 26–27, what is true about the constant β in the following linear equation if its graph has the given property?

$$y = \frac{x}{\beta - 3} + \frac{1}{6 - \beta}.$$

26. Positive slope, positive y -intercept.
27. Perpendicular to the line $y = (\beta - 7)x - 3$.
28. A theater manager graphed weekly profits as a function of the number of patrons and found that the relationship was linear. One week the profit was \$11,328 when 1324 patrons attended. Another week 1529 patrons produced a profit of \$13,275.50.
- Find a formula for weekly profit, y , as a function of the number of patrons, x .
 - Interpret the slope and the y -intercept.
 - What is the break-even point (the number of patrons for which there is zero profit)?
 - Find a formula for the number of patrons as a function of profit.
 - If the weekly profit was \$17,759.50, how many patrons attended the theater?

29. In economics, the *demand* for a product is the amount of that product that consumers are willing to buy at a given price. The quantity demanded of a product usually decreases if the price of that product increases. Suppose that a company believes there is a linear relationship between the demand for its product and its price. The company knows that when the price of its product was \$3 per unit, the quantity demanded weekly was 500 units, and that when the unit price was raised to \$4, the quantity demanded weekly dropped to 300 units. Let D represent the quantity demanded weekly at a unit price of p dollars.
- Calculate D when $p = 5$. Interpret your result.
 - Find a formula for D in terms of p .
 - The company raises the price of the good and the new quantity demanded weekly is 50 units. What is the new price?
 - Give an economic interpretation of the slope of the function you found in part (b).
 - Find D when $p = 0$. Find p when $D = 0$. Give economic interpretations of both these results.
30. In economics, the *supply* of a product is the quantity of that product suppliers are willing to provide at a given price. In theory, the quantity supplied of a product increases if the price of that product increases. Suppose that there is a linear relationship between the quantity supplied, S , of the product described in Problem 29 and its price, p . The quantity supplied weekly is 100 when the price is \$2 and the quantity supplied rises by 50 units when the price rises by \$0.50.
- Find a formula for S in terms of p .
 - Interpret the slope of your formula in economic terms.
 - Is there a price below which suppliers will not provide this product?
- (d) The *market clearing price* is the price at which supply equals demand. According to theory, the free-market price of a product is its market clearing price. Using the demand function from Problem 29, find the market clearing price for this product.
31. When economists graph demand or supply equations, they place quantity on the horizontal axis and price on the vertical axis.
- On the same set of axes, graph the demand and supply equations you found in Problems 29 and 30, with price on the vertical axis.
 - Indicate how you could estimate the market clearing price from your graph.
32. The cholesterol ratio²⁸ is used by many doctors to measure the quantity of the total cholesterol T in the body, measured in milligrams per deciliter of blood (mg/dl), relative to the quantity of good cholesterol G , also measured in mg/dl. In order to minimize risk of cholesterol-related illnesses, the good cholesterol level should always exceed $T/5$ but never be less than $G = 40$.
- Which of the following pairs of T and G values satisfy the inequality $G > T/5$?
 - $T = 100, G = 38$
 - $T = 220, G = 42$
 - $T = 240, G = 60$
 - Which of the pairs in part (a) satisfy the inequality $G > 40$?
 - What do your answers to parts (a) and (b) mean in terms of cholesterol levels?
 - With T on the horizontal axis, graph all the points that satisfy both the inequalities $G > T/5$ and $G > 40$. What do the points in this region represent?

1.6 FITTING LINEAR FUNCTIONS TO DATA

When real data are collected in the laboratory or the field, they are often subject to experimental error. Even if there is an underlying linear relationship between two quantities, real data may not fit this relationship perfectly. However, even if a data set does not perfectly conform to a linear function, we may still be able to use a linear function to help us analyze the data.

Laboratory Data: The Viscosity of Motor Oil

The viscosity of a liquid, or its resistance to flow, depends on the liquid's temperature. Pancake syrup is a familiar example: straight from the refrigerator, it pours very slowly. When warmed on the stove, its viscosity decreases and it becomes quite runny.

The viscosity of motor oil is a measure of its effectiveness as a lubricant in the engine of a car. Thus, the effect of engine temperature is an important determinant of motor-oil performance. Table 1.36 gives the viscosity, v , of motor oil as measured in the lab at different temperatures, T .

²⁸http://www.heart.org/HEARTORG/Conditions/Cholesterol/AboutCholesterol/What-Your-Cholesterol-Levels-Mean_UCM_305562_Article.jsp, accessed February 20, 2014

Table 1.36 The measured viscosity, v , of motor oil as a function of the temperature, T

T , temperature ($^{\circ}\text{F}$)	v , viscosity ($\text{lbs}\cdot\text{sec}/\text{in}^2$)
160	28
170	26
180	24
190	21
200	16
210	13
220	11
230	9

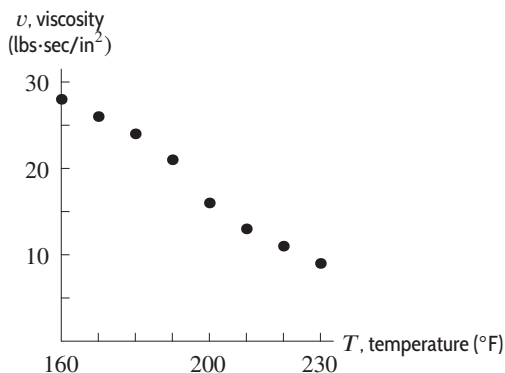

Figure 1.56: The viscosity data from Table 1.36

The *scatter plot* of the data in Figure 1.56 shows that the viscosity of motor oil decreases, approximately linearly, as its temperature rises. To find a formula relating viscosity and temperature, we fit a line to these data points.

Fitting the best line to a set of data is called *linear regression*. One way to fit a line is to draw a line “by eye.” Alternatively, many computer programs and calculators compute regression lines. Figure 1.57 shows the data from Table 1.36 together with the computed regression line,

$$v = 75.6 - 0.293T.$$

Notice that none of the data points lies exactly on the regression line, although it fits the data well.

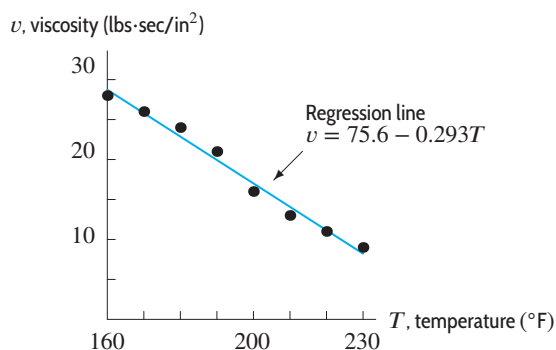

Figure 1.57: A graph of the viscosity data from Table 1.36, together with a regression line (provided by a calculator)

The Assumptions Involved In Finding a Regression Line

When we find a regression line for the data in Table 1.36, we are assuming that the value of v is related to the value of T . However, there may be experimental errors in our measurements. For example, if we measure viscosity twice at the same temperature, we may get two slightly different values. Alternatively, something besides engine temperature could be affecting the oil’s viscosity (the oil pressure, for example). Thus, even if we assume that the temperature readings are exact, the viscosity readings include some degree of uncertainty.

Interpolation and Extrapolation

The formula for viscosity can be used to make predictions. Suppose we want to know the viscosity of motor oil at $T = 196^{\circ}\text{F}$. The formula gives

$$v = 75.6 - 0.293 \cdot 196 \approx 18.2 \text{ lb} \cdot \text{sec}/\text{in}^2.$$

To see that this is a reasonable estimate, compare it to the entries in Table 1.36. At 190°F , the measured viscosity was 21, and at 200°F , it was 16; the predicted viscosity of 18.2 is between 16 and 21. See Figure 1.58. Of course, if we measured the viscosity at $T = 196^\circ\text{F}$ in the lab, we might not get exactly 18.2.

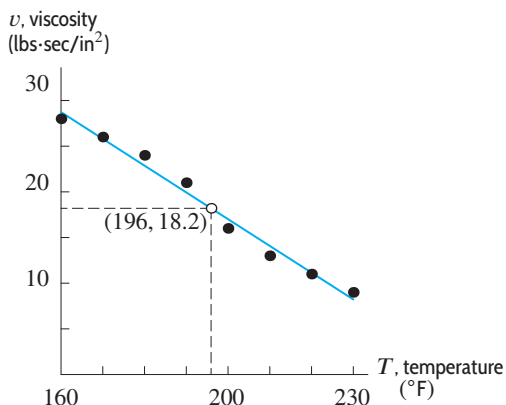

Figure 1.58: Regression line used to predict the viscosity at 196°F

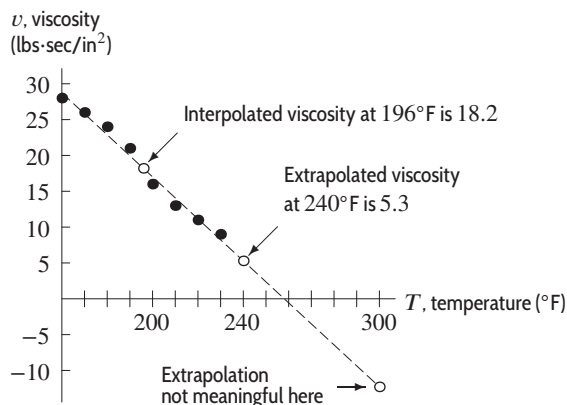

Figure 1.59: The data from Table 1.36 together with the predicted viscosity at $T = 196^\circ\text{F}$, $T = 240^\circ\text{F}$, and $T = 300^\circ\text{F}$

Since the temperature $T = 196^\circ\text{F}$ is between two temperatures for which v is known (190°F and 200°F), the estimate of 18.2 is said to be an *interpolation*. If instead we estimate the value of v at a temperature outside the values for T in Table 1.36, our estimate is called an *extrapolation*.

Example 1 Predict the viscosity of motor oil at 240°F and at 300°F .

Solution At $T = 240^\circ\text{F}$, the formula for the regression line predicts that the viscosity of motor oil is

$$v = 75.6 - 0.293 \cdot 240 = 5.3 \text{ lb} \cdot \text{sec}/\text{in}^2.$$

This is reasonable. Figure 1.59 shows that the predicted point—represented by an open circle on the graph—is consistent with the trend in the data points from Table 1.36.

On the other hand, at $T = 300^\circ\text{F}$ the regression-line formula gives

$$v = 75.6 - 0.293 \cdot 300 = -12.3 \text{ lb} \cdot \text{sec}/\text{in}^2.$$

This is unreasonable because viscosity cannot be negative. To understand what went wrong, notice that in Figure 1.59, the open circle representing the point $(300, -12.3)$ is far from the plotted data points. By making a prediction at 300°F , we have assumed—incorrectly—that the trend observed in laboratory data extended as far as 300°F .

In general, interpolation tends to be more reliable than extrapolation because we are making a prediction on an interval we already know something about instead of making a prediction beyond the limits of our knowledge.

How Regression Works

How does a calculator or computer decide which line fits the data best? We assume that the value of y is related to the value of x , although other factors could influence y as well. Thus, we assume that

we can pick the value of x exactly but that the value of y may be only partially determined by this x -value.

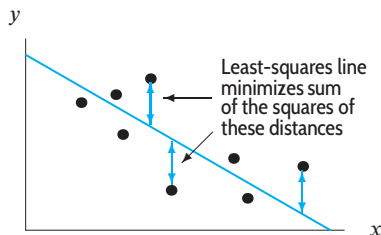

Figure 1.60: A given set of data and the corresponding least-squares regression line

One way to fit a line to the data is shown in Figure 1.60. The line shown was chosen to minimize the sum of the squares of the vertical distances between the data points and the line. Such a line is called a *least-squares line*. There are formulas which a calculator or computer uses to calculate the slope, m , and the y -intercept, b , of the least-squares line.

Correlation

When a computer or calculator calculates a regression line, it also gives a *correlation coefficient*, r . This number lies between -1 and $+1$ and measures how well a particular regression line fits the data. If $r = 1$, the data lie exactly on a line of positive slope. If $r = -1$, the data lie exactly on a line of negative slope. If r is close to 0 , the data may be completely scattered, or there may be a nonlinear relationship between the variables. (See Figure 1.61.)

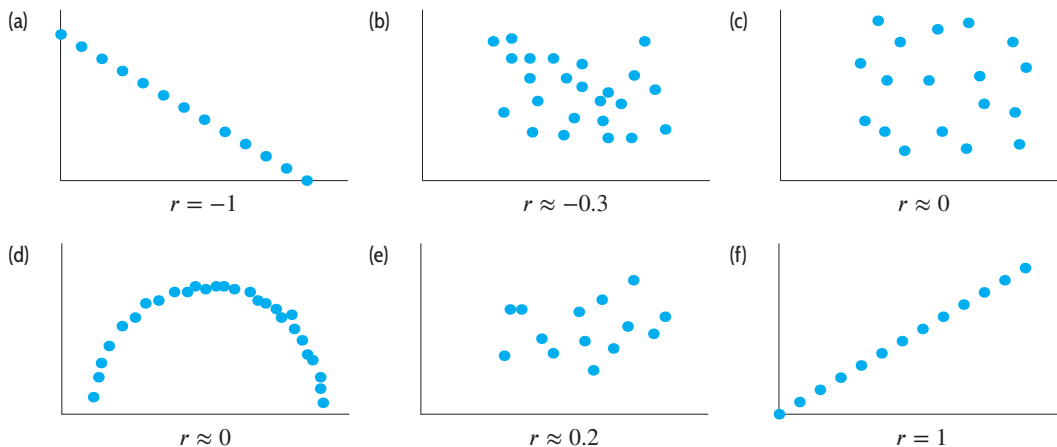

Figure 1.61: Various data sets and correlation coefficients

Example 2 The correlation coefficient for the viscosity data in Table 1.36 on page 47 is $r \approx -0.99$. The fact that r is negative tells us that the regression line has negative slope. The fact that r is close to -1 tells us that the regression line fits the data well.

The Differences Between Relation, Correlation, and Causation

It is important to understand that a high correlation (either positive or negative) between two quantities does *not* imply causation. For example, there is a high correlation between children's reading

level and shoe size.²⁹ However, large feet do not cause a child to read better (or vice versa). Larger feet and improved reading ability are both a consequence of growing older.

Notice also that a correlation of 0 does not imply that there is no relationship between x and y . For example, in Figure 1.61(d) there is a relationship between x and y -values, while Figure 1.61(c) exhibits no apparent relationship. Both data sets have a correlation coefficient of $r \approx 0$. Thus a correlation of $r = 0$ usually implies there is no linear relationship between x and y , but this does not mean there is no relationship at all.

Exercises and Problems for Section 1.6

In Problems 1–6, is the given value of r reasonable? Give a reason for your answer.

1. $r = 1$

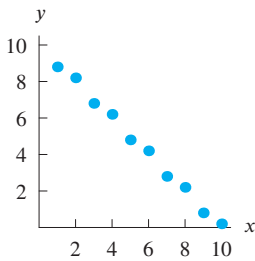

2. $r = 0.7$

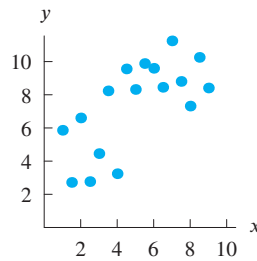

x	1	2	3	4	5
y	3.8	3.2	1.8	1.2	-0.2

6. $r = 0.3$

x	1	2	3	4	5
y	3.477	5.531	14.88	5.924	8.049

3. $r = 0.9$

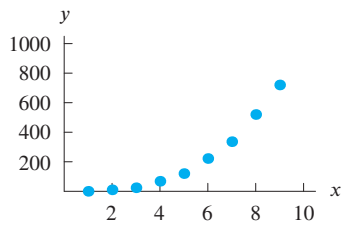

4. $r = -0.9$

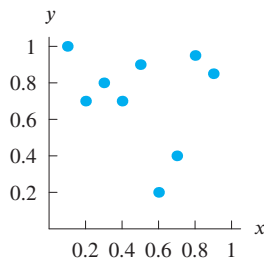

7. Match the r values with scatter plots in Figure 1.62.

$$r = -0.98, \quad r = -0.5, \quad r = -0.25,$$

$$r = 0, \quad r = 0.7, \quad r = 1.$$

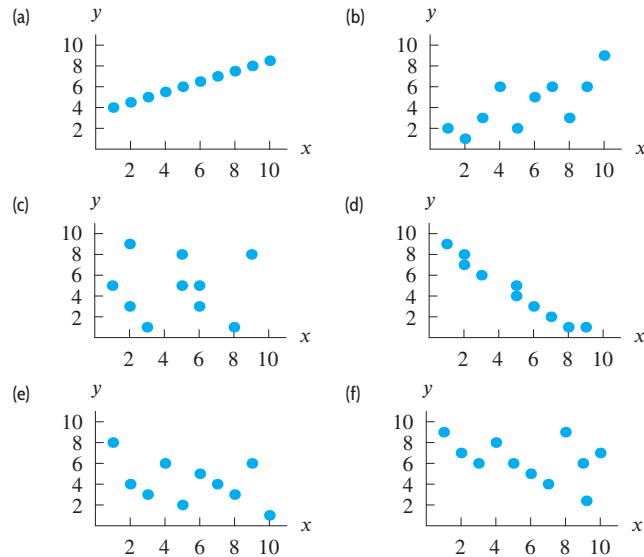

Figure 1.62

²⁹From *Statistics*, 2nd edition, by David Freedman, Robert Pisani, Roger Purves, Ani Adhikari, p. 142 (New York: W.W. Norton, 1991).

8. Table 1.37 shows the number of calories burned per minute by a person walking at 3 mph.
- Make a scatter plot of this data.
 - Draw a regression line by eye.
 - Roughly estimate the correlation coefficient by eye.

Table 1.37

Body weight (lb)	100	120	150	170	200	220
Calories	2.7	3.2	4.0	4.6	5.4	5.9

9. The manager of a small nature park found the regression line for the weekly profits, p in dollars, as a function of the number of visitors, n , was $p = 4n - 2200$.
- How much profit is predicted if 700 people visit the park in a week?
 - Explain the meaning of the slope of the regression line in the context of this problem. Include units.
 - Explain the meaning of the vertical intercept of the regression line in the context of this problem. Include units.
 - How many weekly visitors does the park need if it is not to lose money?
10. An ecologist tracked 290 topi that were born in 2004. The number of topi, T , living each subsequent year is recorded in Table 1.38.
- Make a scatter plot of this data. Let $t = 0$ represent 2004.
 - Draw by eye a line of good fit and estimate its equation. (Round the coefficients to integers.)
 - Use a calculator or computer to find the equation of the least squares line. (Round the coefficients to integers.)
 - Interpret the slope and each intercept of the line.
 - Interpret the correlation between the year and the number of topi born in 2004 that are still alive.

Table 1.38

Year	2004	2005	2006	2007	2008	2009	2010	2011	2012
Topi	290	288	268	206	140	90	64	44	8

11. Students in a chemistry lab are measuring the volume and mass of samples of distilled water and salt water. The results are in Tables 1.39 and 1.40.
- Make scatter plots of the data, with volume on the horizontal axis.
 - Find the lines of best fit for each data set and graph them together with the scatter plot.

- What are the units of the slopes of the lines? Interpret the slopes in the context of the problem.
- What do the slopes tell you about the difference between distilled water and salt water?

Table 1.39 Distilled water

Volume (ml)	20	40	60	80	100
Mass (grams)	19	41	58	82	97

Table 1.40 Salt water

Volume (ml)	20	40	60	80	100
Mass (grams)	22	44.5	63	89	109

12. The rate of oxygen consumption, in microliters per gram per hour, for Colorado potato beetles increases with temperature.³⁰ See Table 1.41.
- Make a scatter plot of this data.
 - Draw an estimated regression line by eye.
 - Use a calculator or computer to find the equation of the regression line. Round constants in the equation to the nearest integer.
 - Interpret the slope and each intercept of the regression equation.
 - Interpret the correlation between temperature and oxygen rate.

Table 1.41

°C	10	15	20	25	30
Oxygen consumption rate	90	125	200	300	375

13. Table 1.42 gives the data on hand strength collected from college freshman using a grip meter.
- Make a scatter plot of these data treating the strength of the preferred hand as the independent variable.
 - Draw a line on your scatter plot that is a good fit for these data and use it to find an approximate equation for the regression line.
 - Using a graphing calculator or computer, find the equation of the least squares line.
 - What would the predicted grip strength in the non-preferred hand be for a student with a preferred hand strength of 37?
 - Discuss interpolation and extrapolation using specific examples in relation to this regression line.

³⁰Adapted from R. E. Rieckes and G. L. Miller, *Ecology*, 4th ed. W. H. Freeman, New York, 1999.

- (f) Discuss why r , the correlation coefficient, is both positive and close to 1.
- (g) Why do the points tend to cluster into two groups on your scatter plot?

Table 1.42 Hand strength for 20 students in kilograms

Preferred	28	27	45	20	40	47	28	54	52	21
Nonpreferred	24	26	43	22	40	45	26	46	46	22
Preferred	53	52	49	45	39	26	25	32	30	32
Nonpreferred	47	47	41	44	33	20	27	30	29	29

14. Table 1.43 shows men's and women's world records for swimming distances from 50 meters to 1500 meters.³¹

- (a) What values would you add to Table 1.43 to represent the time taken by both men and women to swim 0 meters?
- (b) Plot men's time against distance, with time t in seconds on the vertical axis and distance d in meters on the horizontal axis. It is claimed that a straight line models this behavior well. What is the equation for that line? What does its slope represent? On the same graph, plot women's time against distance and

find the equation of the straight line that models this behavior well. Is this line steeper or flatter than the men's line? What does that mean in terms of swimming? What are the values of the vertical intercepts? Do these values have a practical interpretation?

- (c) On another graph plot the women's times against the men's times, with women's times, w , on the vertical axis and men's times, m , on the horizontal axis. It should look linear. How could you have predicted this linearity from the equations you found in part (b)? What is the slope of this line and how can it be interpreted? A newspaper reporter claims that the women's records are about 8% slower than the men's. Do the facts support this statement? What is the value of the vertical intercept? Does this value have a practical interpretation?

Table 1.43 Men's and women's world swimming records

Distance (m)	50	100	200	400	800	1500
Men (sec)	21.64	47.84	104.06	220.08	458.65	874.56
Women (sec)	24.13	53.62	116.64	243.85	496.22	952.10

CHAPTER SUMMARY

• Functions

Definition: a rule which takes certain numbers as inputs and assigns to each input exactly one output number.

Function notation, $y = f(x)$.

Use of vertical line test.

• Average Rate of Change

Average rate of change of $Q = f(t)$ on $a \leq t \leq b$ is

$$\frac{\Delta Q}{\Delta t} = \frac{f(b) - f(a)}{b - a}.$$

Increasing, decreasing functions; identifying from average rate of change.

• Linear Functions

Value of y changes at constant rate.

Tables for linear functions.

• Formulas for Linear Functions

Slope-intercept form: $y = b + mx$.

Point-slope form: $y - y_0 = m(x - x_0)$.

Standard form: $Ax + By + C = 0$.

• Properties of Linear Functions

Interpretation of slope, vertical and horizontal intercepts.

Intersection of lines: Solution of equations.

Horizontal and vertical lines.

Parallel lines: $m_1 = m_2$.

Perpendicular lines: $m_1 = -\frac{1}{m_2}$.

• Fitting Lines to Data

Linear regression; correlation. Interpolation, extrapolation; dangers of extrapolation.

REVIEW EXERCISES AND PROBLEMS FOR CHAPTER ONE

Exercises

1. (a) Suppose x and y are the coordinates of a point on the circle $x^2 + y^2 = 1$. Is y a function of x ? Why or why not?
- (b) Suppose x and y are the coordinates of a point on the part of the circle $x^2 + y^2 = 1$ that is above the x -axis. Is y a function of x ? Why or why not?

³¹Data from *The World Almanac and Book of Facts: 2006*, World Almanac Education Group, Inc., New York, 2006.

2. (a) Is the area, A , of a square a function of the length of one of its sides, s ?
 (b) Is the area, A , of a rectangle a function of the length of one of its sides, s ?
3. (a) Which of the graphs in Figure 1.63 represent y as a function of x ? (Note that an open circle indicates a point that is not included in the graph; a solid dot indicates a point that is included in the graph.)

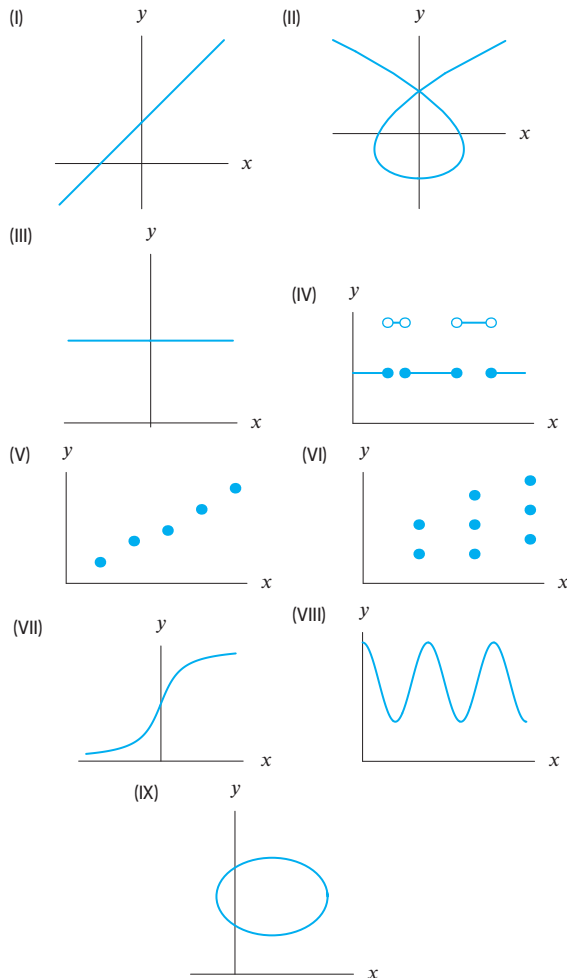

Figure 1.63

- (b) Which of the graphs in Figure 1.63 could represent the following situations? Give reasons.
- SAT Math score versus SAT Verbal score for a small number of students.
 - Total number of daylight hours as a function of the day of the year, shown over a period of several years.

- (c) Among graphs (I)–(IX) in Figure 1.63, find two that could give the cost of train fare as a function of the time of day. Explain the relationship between cost and time for both choices.
4. (a) Make a table of values for $f(x) = 10/(1 + x^2)$ for $x = 0, 1, 2, 3$.
 (b) What x -value gives the largest $f(x)$ value in your table? How could you have predicted this before doing any calculations?
5. Table 1.44 shows data for two populations (in hundreds) for five different years. Find the average rate of change per year of each population over the following intervals.
- 1995 to 2005
 - 2000 to 2012
 - 1995 to 2012

Table 1.44

Year	1995	1997	2000	2005	2012
P_1	53	64	75	86	97
P_2	85	81	77	73	69

6. The following tables represent the relationship between the button number, N , that you push, and the snack, S , delivered by three different vending machines.³²
- One of these vending machines is not a good one to use, because S is not a function of N . Which one?
 - For which vending machine(s) is S a function of N ?
 - For which of the vending machines is N not a function of S ?

Vending Machine #1		Vending Machine #2	
N	S	N	S
1	M&Ms	1	M&Ms or dried fruit
2	pretzels	2	pretzels or Hershey's
3	dried fruit		
4	Hershey's	3	Snickers or fat-free cookies
5	fat-free cookies		
6	Snickers		

Vending Machine #3	
N	S
1	M&Ms
2	M&Ms
3	pretzels
4	dried fruit
5	Hershey's
6	Hershey's
7	fat-free cookies
8	Snickers
9	Snickers

³²For each N , vending machine #2 dispenses one or the other product at random.

7. Figure 1.64 shows the average monthly temperature in Albany, New York, over a twelve-month period. (January is month 1.)

- (a) Make a table showing average temperature as a function of the month of the year.
- (b) What is the warmest month in Albany?
- (c) Over what interval of months is the temperature increasing? Decreasing?

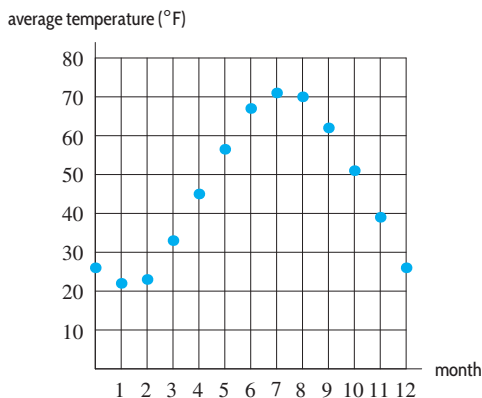

Figure 1.64

8. In 1947, Jesse Owens, the US gold medal track star of the 1930s and 1940s, ran a 100-yard race against a horse. The race, “staged” in Havana, Cuba, is filled with controversy; some say Owens received a head start, others claim the horse was drugged. Owens himself revealed some years later that the starting gun was placed next to the horse’s ear, causing the animal to rear and remain at the gate for a few seconds. Figure 1.65 depicts speeds measured against time for the race.

- (a) How fast were Owens and the horse going at the end of the race?
- (b) When were the participants both traveling at the same speed?

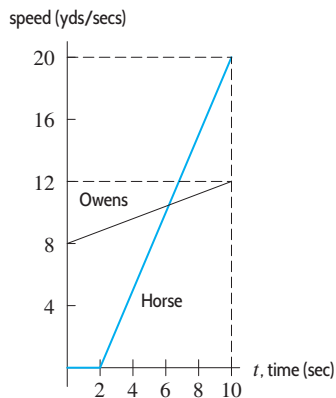

Figure 1.65

In Exercises 9–10, could the table represent a linear function?

9.

λ	1	2	3	4	5
$q(\lambda)$	2	4	8	16	32

 10.

t	3	6	9	12	15
$a(t)$	2	4	6	8	10

Exercises 11–13 give data from a linear function. Find a formula for the function.

11.

x	200	230	300	320	400
$g(x)$	70	68.5	65	64	60

12.

t	1.2	1.3	1.4	1.5
$f(t)$	0.736	0.614	0.492	0.37

13.

t	5.2	5.3	5.4	5.5
$f(t)$	73.6	61.4	49.2	37

14. Without a calculator, match the functions (a)–(c) to the graphs (i)–(iii).

- (a) $f(x) = 3x + 1$
- (b) $g(x) = -2x + 1$
- (c) $h(x) = 1$

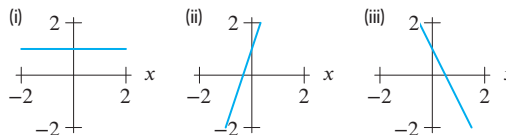

In Exercises 15–16, which line has the greater

- (a) Slope?
- (b) y-intercept?

15. $y = 7 + 2x$, $y = 8 - 15x$

16. $y = 5 - 2x$, $y = 7 - 3x$

Are the lines in Exercises 17–20 perpendicular? Parallel? Neither?

17. $y = 5x + 2$; $y = 2x + 5$

18. $y = 14x - 2$; $y = -\frac{1}{14}x + 2$

19. $y = 3x + 3$; $y = -\frac{1}{3}x + 3$

20. $7y = 8 + 21x$; $9y = 77 - 3x$

Problems

In Problems 21–23, use Table 1.45, which gives values of $v = r(s)$, the eyewall wind profile of a typical hurricane.³³ The eyewall of a hurricane is the band of clouds that surrounds the eye of the storm. The eyewall wind speed v (in mph) is a function of the height above the ground s (in meters).

Table 1.45

s	0	100	200	300	400	500
v	90	110	116	120	121	122
s	600	700	800	900	1000	1100
v	121	119	118	117	116	115

21. Evaluate and interpret $r(300)$.
22. At what altitudes does the eyewall wind speed appear to equal or exceed 116 mph?
23. At what height is the eyewall wind speed greatest?
24. You are looking at the graph of y , a function of x .
 - (a) What is the maximum number of times that the graph can intersect the y -axis? Explain.
 - (b) Can the graph intersect the x -axis an infinite number of times? Explain.
25. A bug starts out ten feet from a light, flies closer to the light, then farther away, then closer than before, then farther away. Finally the bug hits the bulb and flies off. Sketch the distance of the bug from the light as a function of time.
26. Although there were 20 women in the Senate in 2013, the first woman ever elected to the Senate was Hattie Wyatt Caraway of Arkansas. She was appointed to fill the vacancy caused by the death of her husband, then won election in 1932, was reelected in 1938, and served until 1945. Table 1.46 shows the number of female senators at the beginning of the first session of each Congress.³⁴
 - (a) Is the number of female senators a function of the Congress's number, c ? Explain.
 - (b) Is the Congress's number a function of the number of female senators? Explain.
 - (c) Let $S(c)$ represent the number of female senators serving in the c^{th} Congress. What does the statement $S(110) = 16$ mean?
 - (d) Evaluate and interpret $S(112)$.
27. A light is turned off for several hours. It is then turned on. After a few hours it is turned off again. Sketch the light bulb's temperature as a function of time.
28. According to Charles Osgood, CBS news commentator, it takes about one minute to read 15 double-spaced typewritten lines on the air.³⁵
 - (a) Construct a table showing the time Charles Osgood is reading on the air in seconds as a function of the number of double-spaced lines read for 0, 1, 2, ..., 10 lines. From your table, how long does it take Charles Osgood to read 9 lines?
 - (b) Plot this data on a graph with the number of lines on the horizontal axis.
 - (c) From your graph, estimate how long it takes Charles Osgood to read 9 lines. Estimate how many lines Charles Osgood can read in 30 seconds.
 - (d) Construct a formula which relates the time T to n , the number of lines read.
29. The distance between Cambridge and Wellesley is 10 miles. A person walks part of the way at 5 miles per hour, then jogs the rest of the way at 8 mph. Find a formula that expresses the total amount of time for the trip, $T(d)$, as a function of d , the distance walked.
30. A cylindrical can is closed at both ends and its height is twice its radius. Express its surface area, S , as a function of its radius, r . [Hint: The surface of a can consists of a rectangle plus two circular disks.]
31. A lawyer does nothing but sleep and work during a day. There are 1440 minutes in a day. Write a linear function relating minutes of sleep, s , to minutes of work, w .

For the functions in Problems 32–34:

- (a) Find the average rate of change between the points
 - (i) $(-1, f(-1))$ and $(3, f(3))$
 - (ii) $(a, f(a))$ and $(b, f(b))$
 - (iii) $(x, f(x))$ and $(x + h, f(x + h))$
- (b) What pattern do you see in the average rate of change between the three pairs of points?

32. $f(x) = 5x - 4$

33. $f(x) = \frac{1}{2}x + \frac{5}{2}$

34. $f(x) = x^2 + 1$

 Table 1.46 Female senators, S , in Congress c

c	98	100	102	104	106	108	110	112	113
S	2	2	2	8	9	14	16	17	20

³³Data from the National Hurricane Center, www.nhc.noaa.gov/aboutwindprofile.shtml, accessed October 7, 2004.

³⁴http://www.cawp.rutgers.edu/fast_facts/levels_of_office/Congress-Current.php, accessed February 15, 2014

³⁵T. Parker, *Rules of Thumb* (Boston: Houghton Mifflin, 1983).

35. The population, $P(t)$, in millions, of a country in year t , is given by the formula $P(t) = 22 + 0.3t$.
- Construct a table of values for $t = 0, 10, 20, \dots, 50$.
 - Plot the points you found in part (a).
 - What is the country's initial population?
 - What is the average rate of change of the population, in millions of people/year?
36. A woodworker sells rocking horses. His start-up costs, including tools, plans, and advertising, total \$5000. Labor and materials for each horse cost \$350.
- Calculate the woodworker's total cost, C , to make 1, 2, 5, 10, and 20 rocking horses. Graph C against n , the number of rocking horses that he carves.
 - Find a formula for C in terms of n .
 - What is the rate of change of the function C ? What does the rate of change tell us about the woodworker's expenses?
37. Outside the US, temperature readings are usually given in degrees Celsius; inside the US, they are often given in degrees Fahrenheit. The exact conversion from Celsius, C , to Fahrenheit, F , uses the formula

$$F = \frac{9}{5}C + 32.$$

An approximate conversion is obtained by doubling the temperature in Celsius and adding 30° to get the equivalent Fahrenheit temperature.

- Write a formula using C and F to express the approximate conversion.
 - How far off is the approximation if the Celsius temperature is $-5^\circ, 0^\circ, 15^\circ, 30^\circ$?
 - For what temperature (in Celsius) does the approximation agree with the actual formula?
38. Find a formula for the line intersecting the graph of $f(x)$ at $x = 1$ and $x = 3$, where

$$f(x) = \frac{10}{x^2 + 1}.$$

39. Find the equation of the line l in Figure 1.66. The shapes under the line are squares.

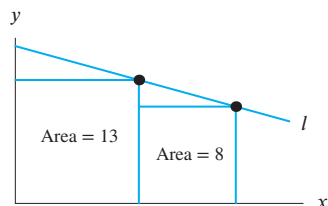
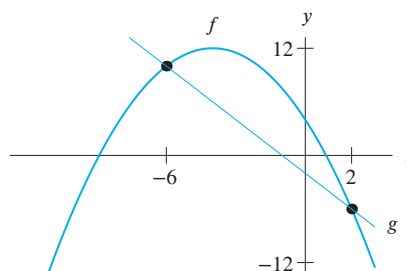

Figure 1.66

40. A bullet is shot straight up into the air from ground level. After t seconds, the velocity of the bullet, in meters per second, is approximated by the formula

$$v = f(t) = 1000 - 9.8t.$$

- Evaluate the following: $f(0), f(1), f(2), f(3), f(4)$. Compile your results in a table.
 - Describe in words what is happening to the speed of the bullet. Discuss why you think this is happening.
 - Evaluate and interpret the slope and both intercepts of $f(t)$.
 - The gravitational field near the surface of Jupiter is stronger than that near the surface of the earth, which, in turn, is stronger than the field near the surface of the moon. How is the formula for $f(t)$ different for a bullet shot from Jupiter's surface? From the moon?
41. Describe a linear (or nearly linear) relationship that you have encountered outside the classroom. Determine the rate of change and interpret it in practical terms.
42. The figure gives graphs of g , a linear function, and of $f(x) = 12 - 0.5(x + 4)^2$. Find a possible formula for g .



43. Write in slope-intercept form and identify the values of b and m :

$$f(r) = rx^3 + 3rx^2 + 2r + 4sx + 7s + 3.$$

44. Find an equation for the line intersecting the graph of f at $x = -2$ and $x = 5$ given that $f(x) = 2 + \frac{3}{x+5}$.
45. A business consultant works 10 hours a day, 6 days a week. She divides her time between meetings with clients and meetings with co-workers. A client meeting requires 3 hours while a co-worker meeting requires 2 hours. Let x be the number of co-worker meetings the consultant holds during a given week. If y is the number of client meetings for which she has time remaining, then y is a function of x . Assume this relationship is linear and that meetings can be split up and continued on different days.
- Graph the relationship between y and x . [Hint: Consider the maximum number of client and co-worker meetings that can be held.]

- (b) Find a formula for y as a function of x .
- (c) Explain what the slope and the x - and y -intercepts represent in the context of the consultant's meeting schedule.
- (d) A change is made so that co-worker meetings take 90 minutes instead of 2 hours. Graph this situation. Describe those features of this graph that have changed from the one sketched in part (a) and those that have remained the same.

46. You start 60 miles east of Pittsburgh and drive east at a constant speed of 50 miles per hour. (Assume that the road is straight and permits you to do this.) Find a formula for d , your distance from Pittsburgh, as a function of t , the number of hours of travel.
47. Find a formula for the line parallel to the line $y = 20 - 4x$ and containing the point $(3, 12)$.
48. Find the equation of the linear function g whose graph is perpendicular to the line $5x - 3y = 6$; the two lines intersect at $x = 15$.
49. Find the coordinates of point P in Figure 1.67.

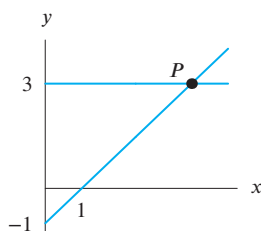

Figure 1.67

50. A cell phone company offers three different “pay as you go” daily cell phone plans.
- Plan A charges \$0.25 per minute.
 - Plan B charges \$.99 per day plus \$0.10 per minute.
 - Plan C charges a fixed rate of \$1.99 per day.
- Let Y_A, Y_B, Y_C represent the daily charges using plans A, B, and C, respectively. Let x be the number of minutes per day spent on the phone.
- (a) Find formulas for Y_A, Y_B, Y_C as functions of x .
- (b) Figure 1.68 shows the functions in part (a). Which function corresponds to which graph?³⁶
- (c) Find the x -values for which plan B is cheapest.

³⁶Actual charges are typically rounded up to the last minute.

³⁷Adapted from “Graphing Henry Aaron’s home-run output” by H. Ringel, *The Physics Teacher*, January 1974, page 43.

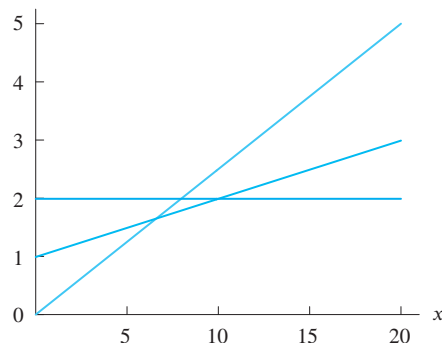

Figure 1.68

51. A commission is a payment made to an employee based on a percentage of sales made. For example, car salespeople earn commission on the selling price of a car. In parts (a)–(d), explain how to choose between the options for different levels of sales.
- (a) A weekly salary of \$100 or a weekly salary of \$50 plus 10% commission.
- (b) A weekly salary of \$175 plus 7% commission or a weekly salary of \$175 plus 8% commission.
- (c) A weekly salary of \$145 plus 7% commission or a weekly salary of \$165 plus 7% commission.
- (d) A weekly salary of \$225 plus 3% commission or a weekly salary of \$180 plus 6% commission.
52. Table 1.47 shows the IQ of ten students and the number of hours of TV each watches per week.
- (a) Make a scatter plot of the data.
- (b) By eye, make a rough estimate of the correlation coefficient.
- (c) Use a calculator or computer to find the least squares regression line and the correlation coefficient. Your values should be correct to four decimal places.

Table 1.47

IQ	110	105	120	140	100	125	130	105	115	110
TV	10	12	8	2	12	10	5	6	13	3

53. For 35 years, major league baseball Hall of Fame member Henry “Hank” Aaron held the record for the greatest number of career home runs. His record was broken by Barry Bonds in 2007. Table 1.48 shows Aaron’s cumulative yearly record³⁷ from the start of his career, 1954, until 1973.
- (a) Plot Aaron’s cumulative number of home runs H on the vertical axis, and the time t in years along the horizontal axis, where $t = 1$ corresponds to 1954.

- (b) By eye, draw a straight line that fits these data well and find its equation.
- (c) Use a calculator or computer to find the equation of the regression line for these data. What is the correlation coefficient, r , to 4 decimal places? To 3 decimal places? What does this tell you?
- (d) What does the slope of the regression line mean in terms of Henry Aaron's home-run record?
- (e) From your answer to part (d), how many home runs do you estimate Henry Aaron hit in each of the years 1974, 1975, 1976, and 1977? If you were told that Henry Aaron retired at the end of the 1976 season, would this affect your answers?

Table 1.48 Henry Aaron's cumulative home-run record, H , from 1954 to 1973, with t in years since 1953

t	1	2	3	4	5	6	7	8	9	10
H	13	40	66	110	140	179	219	253	298	342
t	11	12	13	14	15	16	17	18	19	20
H	366	398	442	481	510	554	592	639	673	713

54. The graph of a linear function $y = f(x)$ passes through the two points $(a, f(a))$ and $(b, f(b))$, where $a < b$ and $f(a) < f(b)$.
- (a) Graph the function labeling the two points.
 - (b) Find the slope of the line in terms of f , a , and b .
55. Let $f(x) = 0.003 - (1.246x + 0.37)$.
- (a) Calculate the following average rates of change:
 - (i) $\frac{f(2) - f(1)}{2 - 1}$
 - (ii) $\frac{f(1) - f(2)}{1 - 2}$
 - (iii) $\frac{f(3) - f(4)}{3 - 4}$
 - (b) Rewrite $f(x)$ in the form $f(x) = b + mx$.

Write the linear function $y = -3 - x/2$ in the forms given in Problems 56–57, assuming all constants are positive.

56. $y = \frac{p}{p-1} - r^2x$ 57. $y = \frac{x+k}{z}$

58. You spend c dollars on x apples and y bananas. In Figure 1.69, line l gives y as a function of x .
- (a) If apples cost p dollars each and bananas cost q dollars each, label the x - and y -intercepts of l . [Note: Your labels will involve the constants p , q or c .]
 - (b) What is the slope of l ?

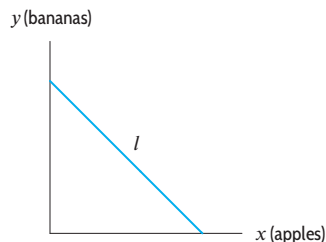

Figure 1.69: Axes not necessarily to scale

59. The apples in Problem 58 cost more than bananas, so $p > q$. Which of the two lines, l_1 or l_2 , in Figure 1.70 could represent $y = f(x)$?

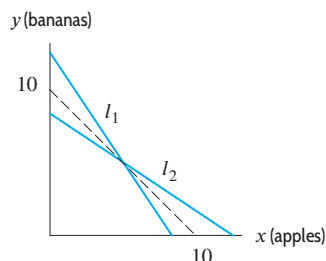

Figure 1.70

60. Many people think that hair growth is stimulated by haircuts. In fact, there is no difference in the rate hair grows after a haircut, but there *is* a difference in the rate at which hair's ends break off. A haircut eliminates dead and split ends, thereby slowing the rate at which hair breaks. However, even with regular haircuts, hair will not grow to an indefinite length. The average life cycle of human scalp hair is 3-5 years, after which the hair is shed.³⁸
- Judy trims her hair once a year, when its growth is slowed by split ends. She cuts off just enough to eliminate dead and split ends, and then lets it grow another year. After 5 years, she realizes her hair won't grow any longer. Graph the length of her hair as a function of time. Indicate when she receives her haircuts.
61. Academics have suggested that loss of worker productivity can result from sleep deprivation. An article in the September 26, 1993, *New York Times* quotes David Poltrack, the senior vice president for planning and research at CBS, as saying that seven million Americans are staying up an hour later than usual to watch talk show host David Letterman. The article goes on to quote Timothy Monk, a professor at the University of Pittsburgh School of Medicine, as saying, "... my hunch is that the effect [on productivity due to sleep deprivation among

³⁸*Britannica Micropaedia*, vol. 5 (Chicago: Encyclopaedia Britannica, Inc., 1989).

this group] would be in the area of a 10 percent decrement.” The article next quotes Robert Solow, a Nobel prize-winning professor of economics at MIT, who suggests the following procedure to estimate the impact that this loss in productivity will have on the US economy—an impact he dubbed “the Letterman loss.” First, Solow says, we find the percentage of the work force who watch the program. Next, we determine this group’s contribution to the gross domestic product (GDP). Then we reduce the group’s contribution by 10% to account for the loss in productivity due to sleep deprivation. The amount of this reduction is “the Letterman loss.”

- (a) The article estimated that the GDP is \$6.325 trillion, and that 7 million Americans watch the show. Assume that the nation’s work force is 118 million people and that 75% of David Letterman’s audience belongs to this group. What percentage of the work force is in Dave’s audience?
 - (b) What percent of the GDP would be expected to come from David Letterman’s audience? How much money would they have contributed if they had not watched the show?
 - (c) How big is “the Letterman loss”?
62. Judging from the graph of $y = f(x)$ in the figure, find a possible formula for the line intersecting it at $x = -2\pi$ and $x = 3\pi$.

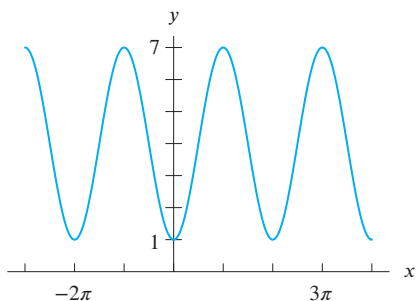

Problems 63–65 refer to Table 1.49, which describes a *boustrophedonic pairing function*.³⁹ We can use this table to list all the positive roots of the positive integers, such as $\sqrt{2}, \sqrt{3}, \sqrt[3]{2}, \sqrt[3]{3}, \sqrt[4]{2}, \sqrt[4]{3}, \dots$, without omitting any. If n is an entry in the table, we let c stand for the column number and r the row number of the entry and define the function g by

$$g(n) = c^{1/r}.$$

For instance, if $n = 6$, then $c = 2$ and $r = 3$ so we have $g(6) = 2^{1/3}$, or $\sqrt[3]{2}$.

³⁹The term *boustrophedonic* means “as the ox turns,” as oxen do when plowing: Notice how the entries in the table, 1, 2, 3, 4, . . . , turn back and forth, like an ox plowing a field.

⁴⁰http://en.wikipedia.org/wiki/ISO_216, accessed January 30, 2008. Note that the actual sizes of A-series paper are rounded to the nearest millimeter.

Table 1.49

	1	2	3	4	5	6	...
1	1	2	9	10	25	26	...
2	4	3	8	11	24	27	...
3	5	6	7	12	23	28	...
4	16	15	14	13	22	29	...
5	17	18	19	20	21	30	...
6	36	35	34	33	32	31	...
⋮	⋮	⋮	⋮	⋮	⋮	⋮	⋮

- 63. Evaluate $g(22)$.
 - 64. Evaluate $g(54)$.
65. Find a solution to $g(n) = \sqrt{3}$. Is this solution unique? Explain your reasoning.

Problems 66–67 are about the A-series of paper. Many countries use A4 paper, which is different from the 8.5 by 11 inch paper used in the US.⁴⁰ Two sheets of A4 paper, if laid side by side (not end to end), are the same size as one sheet of A3 paper. Likewise, two sheets of A3 are the same as one sheet of A2, and so on. See Figure 1.71. Each sheet in the series has the same proportions, length to width, and the largest sheet, A0, has an area of exactly 1 m².

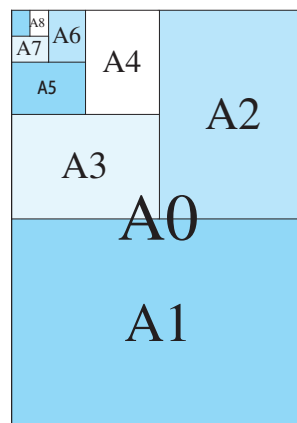

Figure 1.71

66. Let $f(n)$ be the area in cm^2 of the size n sheet in the A-series, so that $f(1)$ is the area of A1 paper, $f(2)$ of A2 paper, and so on. Since 1 m equals 100 cm, we know that $f(0) = (100 \text{ cm})^2 = 10,000 \text{ cm}^2$. Complete the table of values of f .

Table 1.50

n	0	1	2	3	4	5
$f(n)$	10,000					

67. We know that A1 paper has the same proportions (length over width) as A0. Further, the length of A1 paper is the same as the width W of A0, and the width of A1 is half the length L of A0. (See Figure 1.71.)

- (a) Find a formula for L in terms of W . What does your formula tell you about the shape of A-series paper? How does the shape compare to US letter paper?
- (b) Given that A4 paper has area 625 cm^2 , find its width and height.

STRENGTHEN YOUR UNDERSTANDING

Are the statements in Problems 1–54 true or false? Give an explanation for your answer.

- $Q = f(t)$ means Q is equal to f times t .
- A function must be defined by a formula.
- If $P = f(x)$ then P is called the dependent variable.
- Independent variables are always denoted by the letter x or t .
- It is possible for two quantities to be related and yet neither be a function of the other.
- A function is a rule that takes certain values as inputs and assigns to each input value exactly one output value.
- It is possible for a table of values to represent a function.
- If Q is a function of P , then P is a function of Q .
- The graph of a circle is not the graph of a function.
- If $n = f(A)$ is the number of angels that can dance on the head of a pin whose area is A square millimeters, then $f(10) = 100$ tells us that 10 angels can dance on the head of a pin whose area is 100 square millimeters.
- Average speed can be computed by dividing the distance traveled by the time elapsed.
- The average rate of change of a function Q with respect to t over an interval can be symbolically represented as $\frac{\Delta t}{\Delta Q}$.
- If $y = f(x)$ and as x increases, y increases, then f is an increasing function.
- If f is a decreasing function, then the average rate of change of f on any interval is negative.
- The average rate of change of a function over an interval is the slope of a line connecting two points of the graph of the function.
- The average rate of change of $y = 3x - 4$ between $x = 2$ and $x = 6$ is 7.
- The average rate of change of $f(x) = 10 - x^2$ between $x = 1$ and $x = 2$ is the ratio $\frac{10 - 2^2 - 10 - 1^2}{2 - 1}$.
- If $y = x^2$ then the slope of the line connecting the point $(2, 4)$ to the point $(3, 9)$ is the same as the slope of the line connecting the point $(-2, 4)$ to the point $(-3, 9)$.
- A linear function can have different rates of change over different intervals.
- The graph of a linear function is a straight line.
- If a line has the equation $3x + 2y = 7$, then the slope of the line is 3.
- A table of values represents a linear function if

$$\frac{\text{Change in output}}{\text{Change in input}} = \text{constant}.$$
- If a linear function is decreasing, then its slope is negative.
- If $y = f(x)$ is linear and its slope is negative, then in the expression $\frac{\Delta y}{\Delta x}$ either Δx or Δy is negative, but not both.
- A linear function can have a slope that is zero.
- If a line has slope 2 and y -intercept -3 , then its equation may be written $y = -3x + 2$.
- The line $3x + 5y = 7$ has slope $3/5$.
- A line that goes through the point $(-2, 3)$ and whose slope is 4 has the equation $y = 4x + 5$.
- The line $4x + 3y = 52$ intersects the x -axis at $x = 13$.
- If $f(x) = -2x + 7$ then $f(2) = 3$.
- The line that passes through the points $(1, 2)$ and $(4, -10)$ has slope 4.
- The linear equation $y - 5 = 4(x + 1)$ is equivalent to the equation $y = 4x + 6$.
- The line $y - 4 = -2(x + 3)$ goes through the point $(4, -3)$.
- The line whose equation is $y = 3 - 7x$ has slope -7 .
- The line $y = -5x + 8$ intersects the y -axis at $y = 8$.
- The equation $y = -2 - \frac{2}{3}x$ represents a linear function.

37. The lines $y = 8 - 3x$ and $-2x + 16y = 8$ both cross the y -axis at $y = 8$.
38. The graph of $f(x) = 6$ is a line whose slope is six.
39. The lines $y = -\frac{4}{5}x + 7$ and $4x - 5y = 8$ are parallel.
40. The lines $y = 7 + 9x$ and $y - 4 = -\frac{1}{9}(x + 5)$ are perpendicular.
41. The lines $y = -2x + 5$ and $y = 6x - 3$ intersect at the point $(1, 3)$.
42. If two lines never intersect then their slopes are equal.
43. The equation of a line parallel to the y -axis could be $y = -\frac{3}{4}$.
44. A line parallel to the x -axis has slope zero.
45. The slope of a vertical line is undefined.
46. Fitting the best line to a set of data is called linear regression.
47. The process of estimating a value within the range for which we have data is called interpolation.
48. Extrapolation tends to be more reliable than interpolation.
49. If two quantities have a high correlation then one quantity causes the other.
50. If the correlation coefficient is zero, there is not a relationship between the two quantities.
51. A correlation coefficient can have a value of $-\frac{3}{7}$.
52. A value of a correlation coefficient is always between negative and positive 1.
53. A correlation coefficient of one indicates that all the data points lie on a straight line.
54. A regression line is also referred to as a least squares line.

SKILLS REFRESHER FOR CHAPTER ONE: LINEAR EQUATIONS AND THE COORDINATE PLANE

Solving Linear Equations

To solve a linear equation, we isolate the variable.

Example 1 Solve $22 + 1.3t = 31.1$ for t .

Solution We subtract 22 from both sides. Since $31.1 - 22 = 9.1$, we have

$$1.3t = 9.1.$$

We divide both sides by 1.3, so

$$t = \frac{9.1}{1.3} = 7.$$

Example 2 Solve $3 - [5.4 + 2(4.3 - x)] = 2 - (0.3x - 0.8)$ for x .

Solution We begin by clearing the innermost parentheses on each side. Using the distributive law, this gives

$$3 - [5.4 + 8.6 - 2x] = 2 - 0.3x + 0.8.$$

Then

$$\begin{aligned} 3 - 14 + 2x &= 2 - 0.3x + 0.8 \\ 2.3x &= 13.8, \\ x &= 6. \end{aligned}$$

Example 3 Solve $ax = c + bx$ for x . Assume $a \neq b$.

Solution To solve for x , we first get all the terms involving x on the left side by subtracting bx from both sides

$$ax - bx = c.$$

Factoring on the left, $ax - bx = (a - b)x$, enables us to solve for x by dividing both sides by $(a - b)$:

$$\begin{aligned} x(a - b) &= c \\ x &= \frac{c}{(a - b)}. \end{aligned}$$

Since $a \neq b$, division by $(a - b)$ is possible.

Example 4 Solve for q if $p^2q + r(-q - 1) = 4(p + r)$.

Solution We first collect all the terms containing q on the left side of the equation.

$$\begin{aligned} p^2q - rq - r &= 4p + 4r \\ p^2q - rq &= 4p + 5r. \end{aligned}$$

To solve for q , we factor and then divide by the coefficient of q .

$$\begin{aligned} q(p^2 - r) &= 4p + 5r \\ q &= \frac{4p + 5r}{p^2 - r}. \end{aligned}$$

Solving Exactly Versus Solving Approximately

Some equations can be solved exactly, often by using algebra. For example, the equation $7x - 1 = 0$ has the exact solution $x = 1/7$. Other equations can be hard or even impossible to solve exactly. However, it is often possible, and sometimes easier, to find an approximate solution to an equation by using a graph or a numerical method on a calculator. The equation $7x - 1 = 0$ has the approximate solution $x \approx 0.14$ (since $1/7 = 0.142857 \dots$). We use the sign \approx , meaning approximately equal, when we want to emphasize that we are making an approximation.

Solving Linear Inequalities

We can solve a linear inequality like we solve a linear equation, performing operations on both sides of the inequality to isolate the variable. Recall that, when we multiply or divide both sides of an inequality by a positive number, the direction of the inequality does not change. However, multiplying or dividing both sides by a negative number switches the direction of the inequality.

Example 5 Solve the inequalities

- (a) $10 + 0.2d \leq 30$
 (b) $10 + 0.3y < 0.1y$.

Solution (a) We first subtract 10 from each side of the inequality to get

$$0.2d \leq 20.$$

Dividing both sides of the inequality by 0.2 does not switch the direction, so we have

$$d \leq \frac{20}{0.2}.$$

Thus the solution is $d \leq 100$, all values of d smaller than or equal to 100.

(b) We first subtract $0.3y$ from each side of the inequality to get

$$10 < -0.2y$$

Dividing both sides of the inequality by -0.2 switches the direction of the inequality, so we get

$$\frac{10}{-0.2} > y$$

Thus the solution is $-50 > y$, all values of y smaller than -50 .

Example 6 Solve the inequality $ax + k \geq bx$ for x if $a < b$.

Solution We begin by subtracting ax from each side to obtain $k \geq bx - ax$. Since x is common factor of the terms on the right side, we can rewrite this expression as a product,

$$k \geq (b - a)x.$$

We now divide each side of the inequality by $b - a$. Since we are given that $a < b$, we know that $b - a > 0$, so dividing both sides by $b - a$ does not switch the direction of the inequality. Thus we have

$$\frac{k}{b - a} \geq x.$$

Therefore, the solution of the inequality is $x \leq k/(b - a)$.

Systems of Linear Equations

To solve for two unknowns, we must have two equations—that is, two relationships between the unknowns. Similarly, three unknowns require three equations, and n unknowns (n an integer) require n equations. The group of equations is known as a *system* of equations. To solve the system, we find the *simultaneous* solutions to all equations in the system.

We can solve these equations either by *substitution* (see Example 7) or by *elimination* (see Example 8).

Example 7 Solve for x and y in the following system of equations using substitution.

$$\begin{cases} y + \frac{x}{2} = 3 \\ 2(x + y) = 1 - y \end{cases}$$

Solution Solving the first equation for y , we write $y = 3 - x/2$. Substituting for y in the second equation gives

$$2\left(x + \left(3 - \frac{x}{2}\right)\right) = 1 - \left(3 - \frac{x}{2}\right).$$

Then

$$\begin{aligned} 2x + 6 - x &= -2 + \frac{x}{2} \\ x + 6 &= -2 + \frac{x}{2} \\ 2x + 12 &= -4 + x \\ x &= -16. \end{aligned}$$

Using $x = -16$ in the first equation to find the corresponding y , we have

$$\begin{aligned} y - \frac{16}{2} &= 3 \\ y &= 3 + 8 = 11. \end{aligned}$$

Thus, the solution that simultaneously solves both equations is $x = -16, y = 11$.

Example 8 Solve for x and y in the following system of equations using elimination.

$$\begin{cases} 8x - 5y = 11 \\ -2x + 10y = -1. \end{cases}$$

Solution To eliminate y , we observe that if we multiply the first equation by 2, the coefficients of y are -10 and 10 :

$$\begin{cases} 16x - 10y = 22 \\ -2x + 10y = -1. \end{cases}$$

Adding these two equations gives

$$\begin{aligned} 14x &= 21 \\ x &= 3/2. \end{aligned}$$

We can substitute this value for x in either of the original equations to find y . For example,

$$\begin{aligned} 8\left(\frac{3}{2}\right) - 5y &= 11 \\ 12 - 5y &= 11 \\ -5y &= -1 \\ y &= 1/5 \end{aligned}$$

Thus, the solution is $x = 3/2$, $y = 1/5$.

Intersection of Two Lines

The coordinates of the point of intersection of two lines satisfy the equations of both lines. Thus, the point can be found by solving the equations simultaneously.

Example 9 Find the point of intersection of the lines $y = 3 - \frac{2}{3}x$ and $y = -4 + \frac{3}{2}x$.

Solution Since the y -values of the two lines are equal at the point of intersection, we have

$$-4 + \frac{3}{2}x = 3 - \frac{2}{3}x.$$

Notice that we have converted a pair of equations into a single equation by eliminating one of the two variables. This equation can be simplified by multiplying both sides by 6:

$$\begin{aligned} 6\left(-4 + \frac{3}{2}x\right) &= 6\left(3 - \frac{2}{3}x\right) \\ -24 + 9x &= 18 - 4x \\ 13x &= 42 \\ x &= \frac{42}{13}. \end{aligned}$$

We can find the corresponding y -value using either equation:

$$\text{First equation: } y = 3 - \frac{2}{3} \cdot \frac{42}{13} = \frac{11}{13}$$

$$\text{Second equation: } y = -4 + \frac{3}{2} \cdot \frac{42}{13} = \frac{11}{13}$$

We see that the point of intersection, $(\frac{42}{13}, \frac{11}{13}) = (3.2308, 0.8462)$, satisfies both equations. The lines and their point of intersection are shown in Figure 1.72.

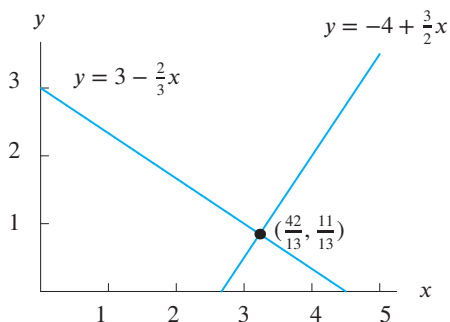

Figure 1.72: Intersection of lines is solution to simultaneous equations

Exercises on Skills for Chapter 1

Solve the equations in Exercises 1–12.

1. $3x = 15$

2. $-2y = 12$

3. $4z = 22$

4. $x + 3 = 10$

5. $w - 23 = -34$

6. $7 - 3y = -14$

7. $13t + 2 = 47$

8. $0.5x - 3 = 7$

9. $3t - \frac{2(t-1)}{3} = 4$

10. $2(r+5) - 3 = 3(r-8) + 21$

11. $B - 4[B - 3(1 - B)] = 42$

12. $1.06s - 0.01(248.4 - s) = 22.67s$

In Exercises 13–22, solve for the indicated variable.

13. $A = l \cdot w$, for l .

14. $l = l_0 + \frac{k}{2}w$, for w .

15. $h = v_0 t + \frac{1}{2}at^2$, for a .

16. $3xy + 1 = 2y - 5x$, for y .

17. $u(v+2) + w(v-3) = z(v-1)$, for v .

18. $S = \frac{rL - a}{r - 1}$, for r .

19. $\frac{a - cx}{b + dx} + a = 0$, for x .

20. $\frac{At - B}{C - B(1 - 2t)} = 3$, for t .

21. $y'y^2 + 2xyy' = 4y$, for y' .

22. $2x - (xy' + yy') + 2yy' = 0$, for y' .

In Exercises 23–32, solve the inequalities.

23. $800 + 3n < 500 + 5n$

24. $7z - 2 > 3z + 5$

25. $3 - 2.1x < 5 - 0.1x$

26. $4 - 0.2t \leq 11 + 0.3t$

27. $12 - 9k \geq 7 - 14k$

- 28. $2y \geq 6 + 5.32y$
- 29. $1 + 0.02y \leq 0.001y$
- 30. $3(5 - t) > 4(t - 3)$
- 31. $0.5(t - 4) < 0.3(t - 7)$
- 32. $5(x + 0.2) \geq x - 3$
- 33. Solve for x in the inequality

$$ax - b > a + 3x.$$

Assume a and b are constants where

- (a) a is larger than 10.
- (b) a is negative.

In Problems 34–36 solve the inequality for x . Assume a and b are constants, and $a < 0$.

- 34. $5ax + a < 6x$
- 35. $3x + 2b < b - 5x + a$
- 36. $ax + 2b > x + 5$

In Exercises 37–41, solve the systems of equations for x and y .

- 37. $\begin{cases} 3x - 2y = 6 \\ y = 2x - 5 \end{cases}$
- 38. $\begin{cases} x = 7y - 9 \\ 4x - 15y = 26 \end{cases}$
- 39. $\begin{cases} 2x + 3y = 7 \\ y = -\frac{3}{5}x + 6 \end{cases}$
- 40. $\begin{cases} 3x - y = 17 \\ -2x - 3y = -4 \end{cases}$
- 41. $\begin{cases} ax + y = 2a \\ x + ay = 1 + a^2 \end{cases}$

Determine the points of intersection for Exercises 42–43.

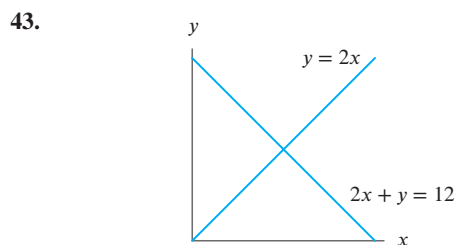
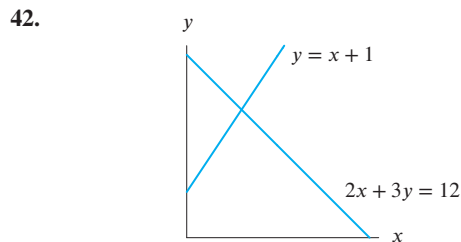

In Exercises 44–49, find the point of intersection of the given lines. Sketch and label a graph that illustrates your solution.

- 44. $y = 20 - 3x$ and $y = 50 - 5x$
- 45. $y = 2 + 0.3x$ and $y = -5 - 0.5x$
- 46. $y = -40 - 3x$ and $30 - 5x$
- 47. $y = 0.1x - 0.397$ and $y = 0.2x - 0.394$
- 48. $y = 3x - 20$ and $y = 0.2x - 4$
- 49. $y = 3000 + 18x$ and $y = 4000 + 37x$

The figures in Exercises 50–51 are parallelograms. Find the coordinates of the labeled point(s).

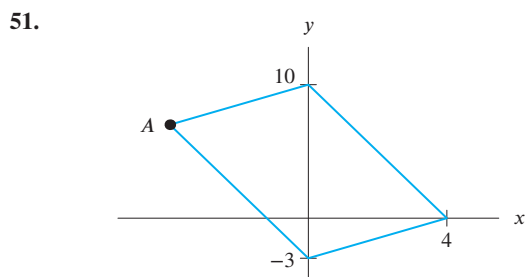
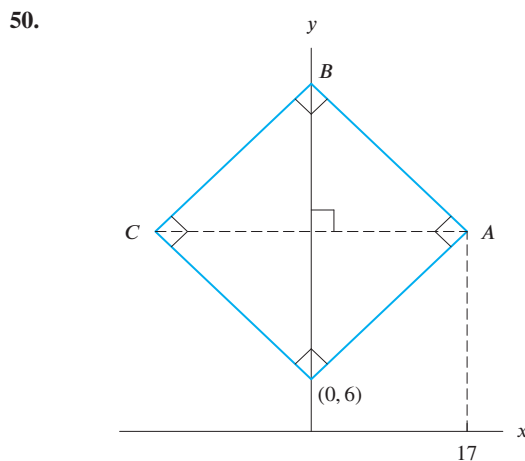

The figures in Exercises 52–55 contain a semicircle with the center marked. Find the coordinates of A, a point on the diameter, and B, an extreme point (highest, lowest, or farthest to the right).

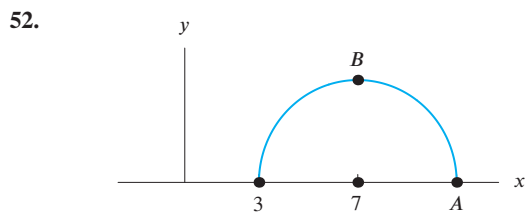

53.

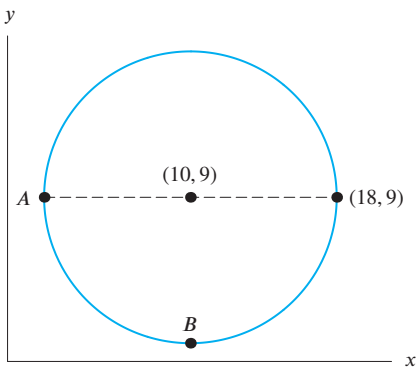

54.

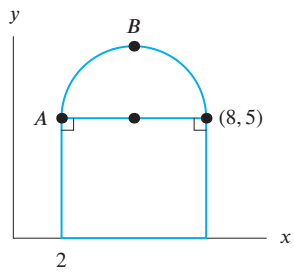

55.

