

Chapter 1

Exploring the Interface

Before you can start to use the new capabilities of the AutoCAD® 2021 software, you must become familiar with the basics. If you're completely new to AutoCAD, you'll want to read this first chapter carefully. It introduces you to many basic operations of AutoCAD, such as opening and closing files, getting a close-up look at part of a drawing, and changing a drawing. If you're familiar with earlier versions of AutoCAD, you should review this chapter anyway to get acquainted with the features that you haven't already used.

AutoCAD 2021 offers updates that cover a wide range of features.

The Trim and Extend commands have been enhanced with quick mode that automatically selects all objects to trim/extend to. The Revision Cloud command now requires only one distance entry for arc length. The new Breakatpoint command will break objects with one point selection. The new quick mode for the Measuregeom command will give you the 2D area of a closed object with one click. There is a new Drawing History Support feature when signed into your Autodesk account and storing files in certain cloud-based services. Graphics performance when executing pans, zooms, and regenerations has been enhanced. The enhanced Blocks palette allows users to access blocks anywhere any time from any drawing. The Xref Compare feature allows you to compare files that are referenced seeing how they are different.

Before you begin the exercises in this chapter, make sure that you have loaded the sample files from this book's web page at www.wiley.com/go/masteringautocad2021. See the introduction for details. If you have purchased the e-book version, please see the introduction for instructions on how to download the sample files.

IN THIS CHAPTER, YOU WILL LEARN TO

- ◆ Use the AutoCAD window
- ◆ Get a closer look with the Zoom command
- ◆ Save a file as you work
- ◆ Make changes and open multiple files

Taking a Guided Tour

First, you'll get a chance to familiarize yourself with the AutoCAD screen and how you communicate with AutoCAD. As you do the exercises in this chapter, you'll also get a feel for how to

work with this book. Don't worry about understanding or remembering everything you see in this chapter. You'll get plenty of opportunities to probe the finer details of the program as you work through the later chapters. To help you remember the material, we have included a brief set of questions at the end of each chapter. For now, just enjoy your first excursion into AutoCAD.

AUTOCAD REFERENCES IN THIS BOOK

In this chapter and throughout the rest of the book, when we say AutoCAD, we mean both AutoCAD and AutoCAD LT[®]. Some topics apply only to AutoCAD. In those situations, you'll see an icon indicating that the topic applies only to AutoCAD and not to AutoCAD LT. If you're using AutoCAD LT 2021, these icons can help you focus on the topics that are more relevant to your work by letting you skim over items that do not apply.

AutoCAD 2021 is designed to run on Windows 8.1 with Update KB2919355, and Windows 10 version 1903 or higher. This book was written using AutoCAD 2021 running on Windows 10.

Launching AutoCAD

If you've already installed AutoCAD (see Appendix B, "Installing and Setting Up AutoCAD") and are ready to jump in and take a look, proceed with the following steps to launch the program:

1. Choose Start. Navigate through the Programs lists until you reach AutoCAD 2021. Open the list of AutoCAD 2021 options by clicking the down arrow and then select AutoCAD 2021.

You can also double-click the AutoCAD 2021 icon on your Windows Desktop. AutoCAD LT users will use AutoCAD LT 2021 in place of AutoCAD 2021.

The AutoCAD Start tab appears, offering options to open existing drawings or to create a new drawing. You may also see a notification area and an account connection area.

2. Click the Start Drawing thumbnail in the left side of the view under "Get Started" (see Figure 1.1).

The AutoCAD window displays a blank default document named Drawing1.dwg. If there are any other palettes on the screen, close them for now. Instructions will be given to open any palettes that are required.

If you're using the trial version, you'll see the Product License Activation window before step 2. This window shows you the number of days you have left in the trial version. You can also activate the product here if you purchase a license. Click the Try button to continue opening the program. Now let's look at the AutoCAD window in detail. Don't worry if it seems like a lot of information. You don't have to memorize it, but by looking at all of the parts, you'll be aware of what is available in a general way.

FIGURE 1.1
The Start tab offers easy access to previous work.

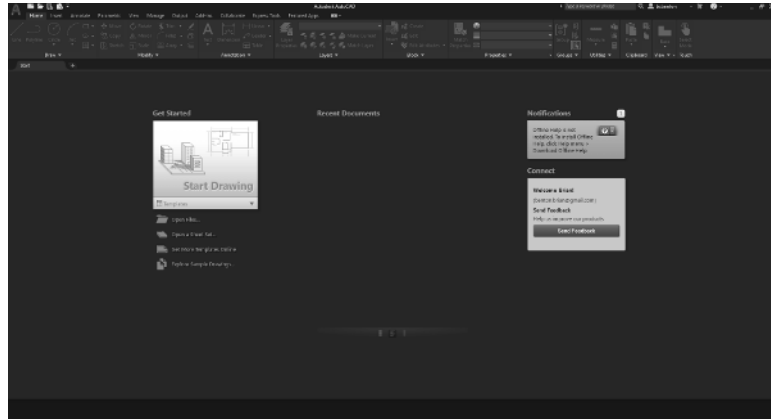

The AutoCAD Window

Certification
Objective

The AutoCAD program window is divided into several parts:

- ◆ Application menu
- ◆ Quick Access toolbar
- ◆ InfoCenter
- ◆ Ribbon
- ◆ Drawing tabs
- ◆ Drawing area
- ◆ UCS icon (User Coordinate System icon)
- ◆ Viewport controls
- ◆ ViewCube®
- ◆ Navigation bar
- ◆ Command window
- ◆ Status bar

Figure 1.2 shows a typical layout of the AutoCAD program window. You can organize the AutoCAD window into any arrangement you want and save it as a *workspace*. You can save and recall a workspace at any time using the Workspace Switching tool in the Quick Access toolbar. (You'll learn more about this tool in the next chapter.) The default workspace in Figure 1.2 is called the Drafting & Annotation workspace, and it is one of several workspaces built into AutoCAD.

FIGURE 1.2
A typical arrangement of the elements in the AutoCAD window

Application menu
Quick access toolbar
Drawing tabs

Help and Information Area
Ribbon
UCS

Viewport Controls
Status Bar
Command Window

Drawing Area
ViewCube
Navigation Bar

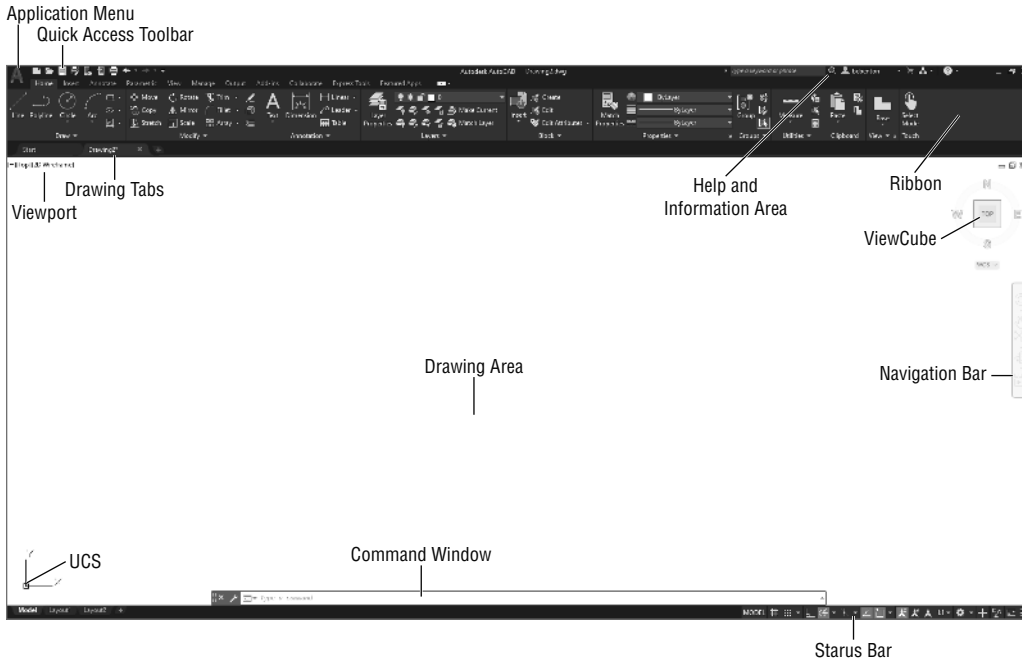

AUTOCAD FOR 3D

For 3D modeling work, AutoCAD offers the 3D Modeling workspace and 3D drawing templates. The combination of these two features can make AutoCAD look like a very different program, but beneath the different appearance, the underlying program is the same. You'll learn more about workspaces and templates later in this chapter and in Chapter 24, "Customizing the Workspace Environment, Linetypes, and Hatch Patterns." Part 4 of this book shows you the 3D features and tools of AutoCAD in more detail.

In the upper-left corner of the AutoCAD program window, the red AutoCAD icon displays the Application menu, which offers a set of options not directly related to drawing; we'll elaborate on this menu in the next section. The Quick Access toolbar at the top of the drawing area (shown in Figure 1.3) includes the basic file-handling functions, which you find in nearly all Windows programs. The Help and Information Area is the AutoCAD online help facility; you'll learn more about it in Chapter 2, "Creating Your First Drawing." The Ribbon uses icons to provide nearly all of the commands that you'll need; you'll learn more about it in the section "Using the Ribbon" later in this chapter.

FIGURE 1.3

The Quick Access toolbar, featuring basic Windows file-handling functions, appears above the Ribbon. Quick Access Toolbar Help and Information Area Ribbon Tabs Ribbon Panels Ribbon Panel Title Bars

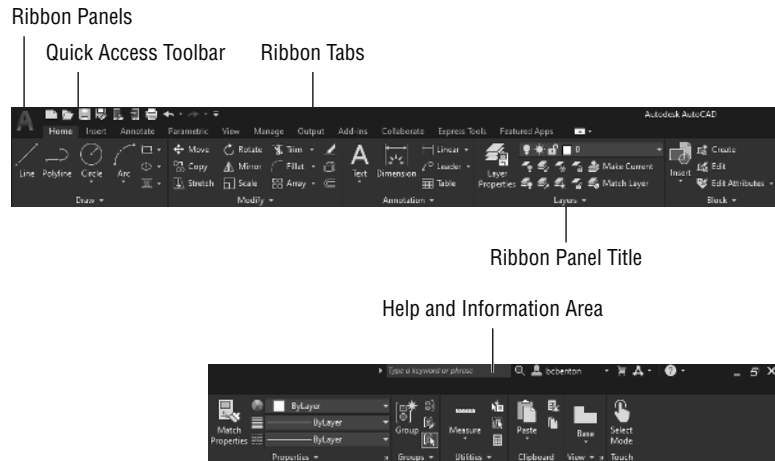

The drawing area occupies most of the screen. Everything you draw appears in this area. As you move your mouse around, crosshairs appear to move within the drawing area. This is the drawing cursor that lets you point to locations in the drawing area. You'll get your first chance to work with the drawing area later in the section "Picking Points in the Drawing Area."

Just above the drawing area are the Drawing tabs that let you create new drawings or switch between open drawings in a way similar to web browsers. Notice the X in the active tab, which lets you close the current drawing, and the plus icon just to the right of the tab(s), which lets you create a new drawing or open an existing one. When you click the plus icon, a new drawing tab appears that you can save as a new file. Right-click the plus icon and a context menu opens that offers you the option to open an existing drawing or to create a new one in the form of an additional tab by using a template.

If you hover over the Drawing tab, you'll see preview images of the model space and layout space of the drawing. You'll learn more about model space and layout space later in this chapter.

Within the drawing area, you see several items along the side and in the corners. The UCS icon appears in the lower-left corner. You'll learn more about the UCS icon in a moment. In the upper-right corner, you see the ViewCube. The ViewCube is primarily for 3D modeling, and we look at those techniques in Chapter 20, "Creating 3D Drawings." You'll also see a Navigation bar along the right edge of the AutoCAD window. This bar offers tools that you can use to get around in your drawing. Basic tools like Zoom and Pan can be found here as well as some advanced tools for viewing 3D models.

The Viewport controls in the upper-left corner of the drawing area offer menu options to control 3D and 2D views and visual styles, and they duplicate some of the functions of the ViewCube. You'll explore the Viewport controls when you delve into 3D modeling in Chapter 23, "Exploring 3D Mesh and Surface Modeling."

Just below the drawing area in the lower-left corner are the Model and Layout tabs. These tabs enable you to switch quickly between different types of views called the *model space* and *layout space* views. You'll get to see firsthand how these views work in a section called "Working with AutoCAD" later in this chapter.

The Command window (which might also be referred to as the command-line interface or Command prompt), located just below the drawing area, gives you feedback about the AutoCAD commands as you use them. You can move and resize this window just as you move and resize other display components. The Command window can be placed in a docked position, as shown in Figure 1.4, by dragging it into the status bar. We'll elaborate on the Command window in the section "Working in the Command Window" later in this chapter.

FIGURE 1.4

The Command window and the status bar
UCS Icon
Model and Layout Tabs
Command Window
Status Bar

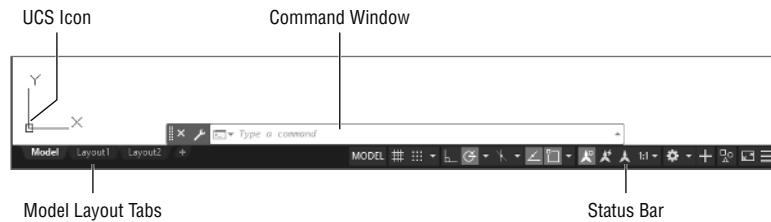

Below the Command window is the status bar (also shown in Figure 1.4). The status bar gives you information at a glance about the state of the drawing. The tools in the status bar offer aids to the drafting process.

Using the Application Menu

Certification
Objective

The Application menu offers tools to help you manage your AutoCAD files. It is basically the File pull-down menu from earlier versions of AutoCAD. Try it to see how it works:

1. Click the Application menu icon in the upper-left corner of the AutoCAD window. A list of options appears.

2. Move the cursor slowly down the list of options in the left column. As you highlight the options, additional options appear in a column to the right.
3. Highlight the Export option to see the various formats available for export (see Figure 1.5).

FIGURE 1.5

The Export option in the Application menu showing the list of export options



The Application menu also gives you a convenient way to find recently used files or to get to a file you already have open. If you move your cursor away from the list of options to the left in the Application menu, you'll see Recent Documents in the upper-left portion of the menu. You'll also see two icon tools, named Open Documents and Recent Documents (see Figure 1.6).

The Open Documents option lets you quickly change from one open file to another when you are viewing your files full-screen. The Recent Documents option displays a list of documents on which you've recently worked.

You can use the View tool in the upper-right portion of the Application menu to select the way the list of files is displayed in a manner similar to the way you would use the Windows Explorer View option. You can click this icon and select Small Images to have the list display the files with thumbnail images of their content. Hover over a filename, and you will see a tool tip that displays a larger thumbnail of the drawing.



Figure 1.6

The Open Documents
and Recent Documents
tools
Open Documents
Recent Documents
List of Recent Documents

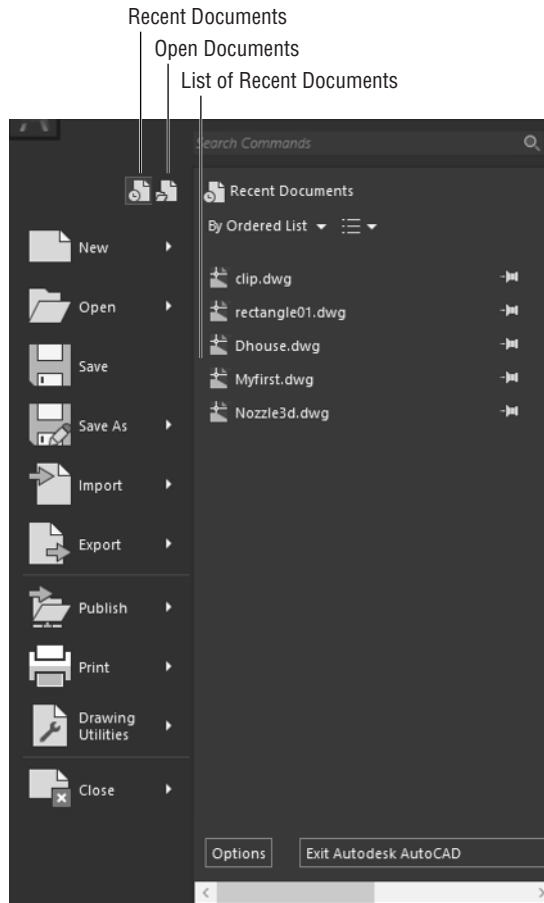

Using the Ribbon

Certification
Objective

The most prominent feature in the AutoCAD window, besides the drawing area, is the Ribbon (see Figure 1.7). This is where you'll be selecting tools to draw, edit, or perform other functions. The Ribbon contains a set of panels representing groups of tools and features. The name of each Ribbon panel is found in its title bar at the bottom of the panel. Tabs that appear above the Ribbon panels further organize them. Each tool in the Ribbon offers a tool tip and cue card that provides a short description to help you understand what the tool icon represents.

If you see only the Ribbon tabs, click the arrowhead button in the Ribbon Control tool. If you don't even see the tabs, type **Ribbon**↵.

Move the arrow cursor onto one of the Ribbon panel tools and leave it there for a moment; you'll see a tool tip appear just below the cursor. Hold the cursor there a bit longer and the tool tip changes to give you even more information about the tool.

In most cases, you'll be able to guess what each tool does by looking at its icon. The icon with an arc in the Draw Ribbon panel, for instance, indicates that the tool draws arcs; the one with the circle shows that the tool draws circles; and so on. For further clarification, the tool tip gives you the name of the tool.



FIGURE 1.7

A typical cue card from a
Ribbon panel tool
Ribbon Tabs
Ribbon Panels
Ribbon Panel Title Bars
Tool Name
Description/Tutorial
Keyboard Command
Equivalent
Context-Sensitive Help

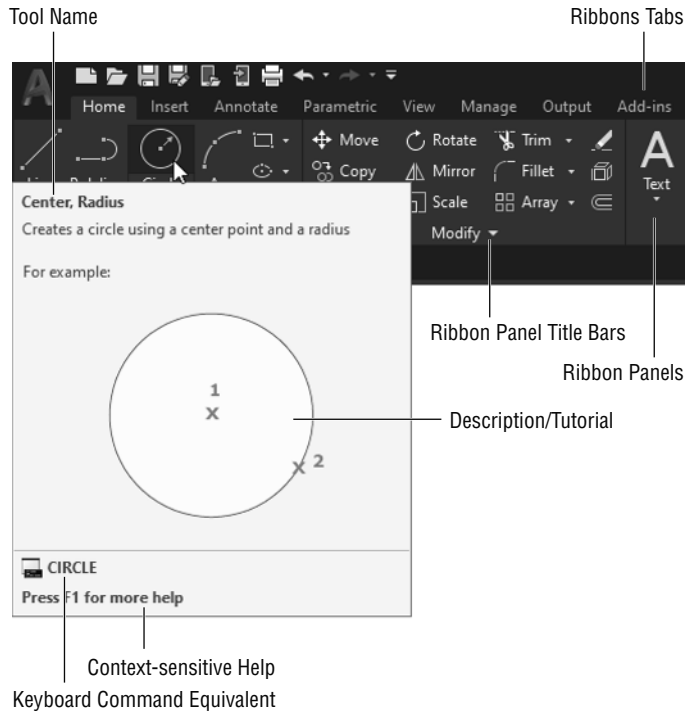

COMMUNICATING WITH THE COMMAND WINDOW AND DYNAMIC INPUT DISPLAY

AutoCAD is the perfect servant: It does everything you tell it to do and no more. You communicate with AutoCAD by using tools and menu options, which invoke AutoCAD commands. A *command* is a single-word instruction you give to AutoCAD telling it to do something, such as draw a line (the Line tool in the Home tab's Draw panel) or erase an object (the Erase tool in the Home tab's Modify panel). Whenever you invoke a command, either by typing it or by selecting an option or tool, AutoCAD responds by presenting messages to you in the Command window and the Dynamic Input display or by displaying a dialog box. The Dynamic Input display is the display of information that appears at the cursor and consists of messages, dimensions, and coordinates.

The messages in the Command window, or in the Dynamic Input display, often tell you what to do next, or they may display a list of available options. A single command often presents a series of messages that you answer to complete the command. These messages serve as an aid to new users who need a little help. If you ever get lost while using a command or forget what you're supposed to do, look at the Command window for clues. As you become more comfortable with AutoCAD, you'll find that you won't need to refer to these messages as frequently.

You can also right-click to display a set of options that relate directly to your current activity. For example, if you right-click before picking the first point for the Rectangle command, a set of options appears displaying the same options that are listed in the Command prompt along with some additional options.

Finally, the Dynamic Input display allows you to enter dimensional data of objects as you draw them. Besides echoing the command-line messages, the Dynamic Input display shows temporary dimensions, coordinates, and angles of objects that you're drawing and editing. As you enter coordinate or angle values through the keyboard, they appear in the Dynamic Input display. You can easily turn the Dynamic Input display on or off by clicking the Dynamic Input tool when it is visible in the status bar or by setting the Dynmode command to 0 for off or 3 for on. When the Dynamic Input display is turned off, your keyboard input appears only in the Command window.

As a new user, you'll find these tool tips helpful because they show you the name of the tool and a brief description of how to use it. Typically, when we ask you to select a tool, we'll use the name shown in the tool tip to help you identify the tool. In the case of a tool with flyouts, the tool name changes under different conditions. For those tools, we'll use a general description to identify the tool. You'll learn more about flyouts a bit later in this chapter (see the section "Understanding Flyouts").

As you work through this book, we'll ask you to select tools from the Ribbon panels. You'll often be asked to switch between different tabs to select tools from other sets of panels. To make the process simpler to read, we'll use a somewhat abbreviated description of a tool's location. For example, for the Line tool we'll say, "Click the Line tool in the Home tab's Draw panel." For the Move tool, we'll say, "Click the Move tool in the Home tab's Modify panel."

EXPANDING HIDDEN PANELS

Certification
Objective

In addition to the visible tools, some buttons are hidden from view. You can expand many of the Ribbon panels to select more of them. If you see an arrowhead to the right of a panel's title bar, you can click the title bar to expand the panel (see Figure 1.8). The panel expands to reveal additional tools. If you move the cursor to the drawing area, the expanded panel shrinks to its original size. You can also click the pushpin icon in the expanded panel title bar to lock the panel in its open position.

Figure 1.8

The arrowhead in the panel title bar tells you that additional tools are available.

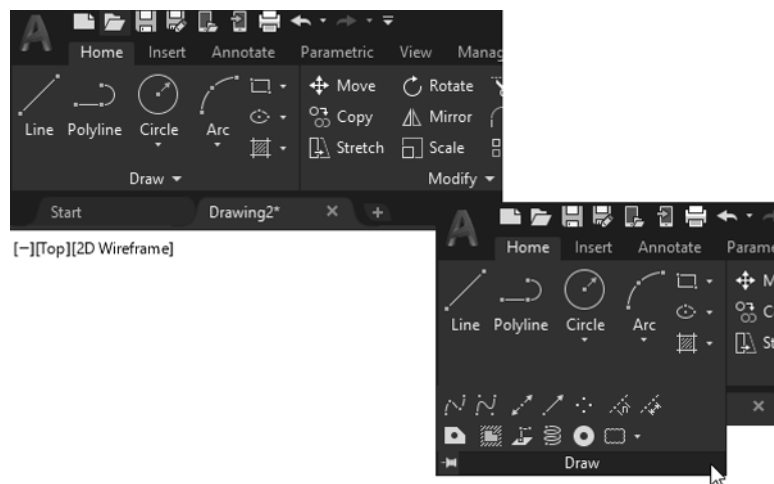

From now on, we'll refer to the location of additional tools as the expanded panel. For example, we'll say, "Click the Ray tool in the expanded Draw panel" when we want you to select the Ray tool.

If you are working on a smaller screen with low resolution, some of the Ribbon panels to the far right may look different from what you are shown in this book. On a low-resolution screen, AutoCAD will automatically reduce the size of the panels to the right of the Ribbon so that they show only their title (see Figure 1.9).

Figure 1.9

The Layers, Block, Properties, Groups, Utilities, Clipboard, and View panels are reduced to single icons with a smaller AutoCAD window.

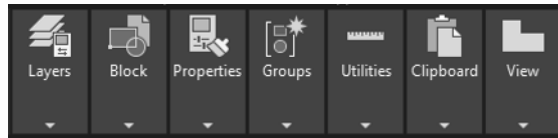

To see the tools, hover over the panel (see Figure 1.10).

Figure 1.10

Hover over the panel to see the tools.

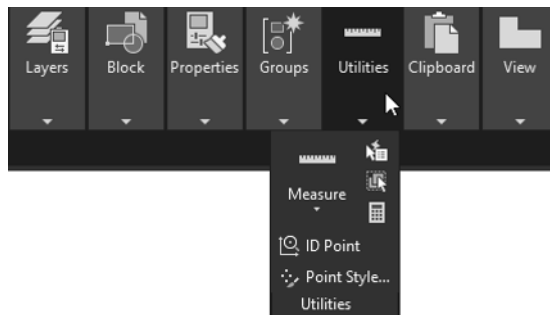

Finally, the Workspace drop-down menu in the Quick Access toolbar may be hidden from view in a low-resolution display. If you don't see these options in your AutoCAD window, click the double arrowhead icon to the far right of the Quick Access toolbar to reveal it. If you still don't see the Workspace menu, click the downward-pointing arrow icon at the far-right end of the Quick Access toolbar and select Workspace. See "Can't Find the Tool or Panel We're Discussing?" later in this chapter for more on "missing" interface items.

UNDERSTANDING FLYOUTS

The *flyouts* are one more feature that you'll want to know about. Flyouts are similar to expanded panels because you can click an arrowhead to gain access to additional tools. Unlike a whole panel, however, flyouts give you access to different methods for using a particular tool. For example, AutoCAD lets you draw circles in several ways, so it offers a flyout for the Circle tool in the Home tab's Draw panel. If you click the arrowhead below the Circle icon in the Draw panel, you'll see additional tools for drawing circles (see Figure 1.11).

Figure 1.11
Flyouts

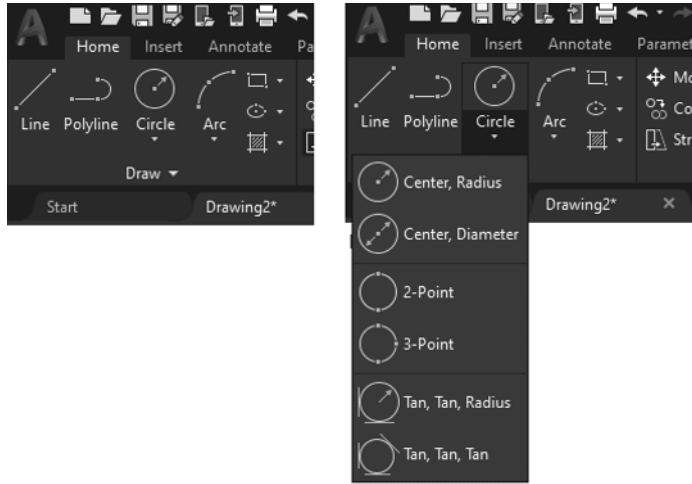

If you select a tool option from a flyout, that option becomes the default tool for the icon you chose. For example, when you hover your cursor over the Circle icon in the Draw panel, the tool tip shows “Center, Radius” for the tool’s name. If you click the arrowhead below the Center, Radius tool and select 2-Point, then 2-Point becomes the default tool and you’ll see “2-Point” for the name of the tool in the tool tip (see Figure 1.12).

Figure 1.12
The tool with a flyout will change to the last tool used.

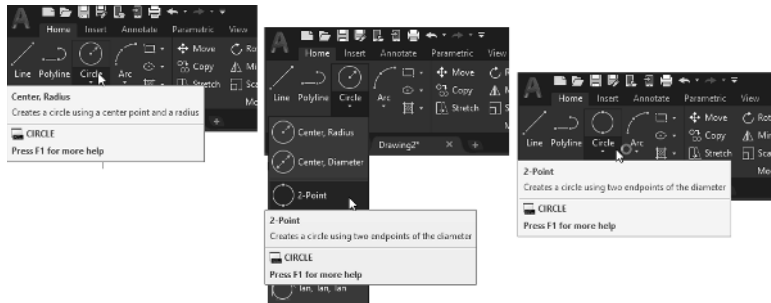

GENERAL TOOL NAMES VS. TOOL TIP NAMES

Because the tool tip for tools with flyouts can change, describing them by name can be a bit problematic. The name may have changed based on the last tool you used from a flyout. For this reason, if a tool has a flyout, we’ll refer to it by a general name that is related to the set of tools contained within it rather than by the tool tip name. For example, we’ll call the circle icon tool the Circle tool rather than the Center, Radius tool.

Circle tool

TOOLS VS. THE KEYBOARD

Throughout this book, you'll be told to select tools from the Ribbon panels to invoke commands. For new and experienced users alike, the Ribbon panels offer an easy-to-remember method for accessing commands. If you're an experienced AutoCAD user, you can type commands directly from the keyboard. Most of the keyboard commands you know and love still work as they did before.

Many tools and commands have *aliases*. Aliases are one-, two-, or three-letter abbreviations of a command name. As you become more proficient with AutoCAD, you may find these aliases helpful. As you work through this book, the shortcuts will be identified for your reference.

Finally, if you're feeling adventurous, you can create your own aliases and keyboard shortcuts for executing commands by adding them to the AutoCAD support files. Chapter 24 discusses how to customize menus, Ribbon panels, toolbars, and keyboard shortcuts.

Picking Points in the Drawing Area

Now that you've seen the general layout of AutoCAD, take a look at the coordinate readout and the drawing cursor to get a sense of how the parts of the AutoCAD screen work together:

1. Move the cursor around in the drawing area.

As you move it, notice how the coordinate readout changes to tell you the cursor's location. It shows the coordinates in an X, Y, Z format. If the coordinates are not shown on the status bar,

- a. Click the customization tool at the bottom-right corner of the AutoCAD window.
- b. Click the Coordinates option check mark.

The coordinate readout will then be visible. The Customization tool looks like three horizontal bars. See "Can't Find the Tool or Panel We're Discussing?" later in this chapter for more information.

2. Place the cursor in the middle of the drawing area and click the left mouse button.
3. Move the cursor and a rectangle follows.

This is a *window selection*; you'll learn more about this window in Chapter 2. You also see a coordinate readout following the cursor and the message Specify opposite corner or. This display at the cursor is called the *Dynamic Input display*. You'll learn more about it a little later in this chapter (see Figure 1.13).

Figure 1.13
The Dynamic Input display cursor

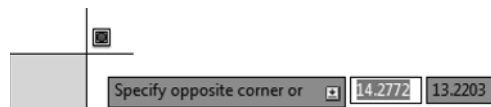

4. Move the cursor a bit in any direction and then click the left mouse button again.
Notice that the window selection disappears, as does the Dynamic Input display.

5. Try picking several more points in the drawing area.

Notice that, as you click, you alternately start and end a window selection. If you happen to click and drag, you will see a lasso selection (see “Click and Drag to Lasso Objects” in Chapter 2 for more on the lasso selection method).

If you happen to click the right mouse button, a context menu appears. A right-click frequently opens a menu containing options that are *context sensitive*. This means the contents of the menu depend on the location where you right-click as well as the command that is active at the time. If there are no appropriate options at the time of the right-click, AutoCAD treats the right-click as an Enter (↵) keystroke. You’ll learn more about these options as you progress through the book. For now, if you happen to open this menu by accident, press the Esc key to close it.

Using the UCS Icon

In the lower-left corner of the drawing area, you see an L-shaped line. This is the *User Coordinate System (UCS)* icon, which tells you your orientation in the drawing. This icon becomes helpful as you start to work with complex 2D drawings and 3D models. The X and Y indicate the x- and y-axes of your drawing. Chapter 21, “Using Advanced 3D Features,” discusses this icon in detail. For now, you can use it as a reference to tell you the direction of the axes, just be sure to avoid clicking and dragging the icon itself.

IF YOU CAN’T FIND THE UCS ICON

The UCS icon can be turned on and off, so if you’re on someone else’s system and you don’t see the icon or it doesn’t look like it does in this chapter, don’t panic. See Chapter 21 for more information.



Working in the Command Window

As mentioned earlier, at the bottom of the screen, just above the status bar, is a small horizontal window called the *Command window*. Here AutoCAD displays responses to your input while you’re using a command. By default, it shows one line of text. This line shows the current responses to your command input as well as command options. As you work through a command, you’ll see more responses, with earlier responses scrolling upward in faded text. You can view text that has scrolled out of sight by clicking the up-pointing arrowhead at the far right of the Command window.

Right now, the command line displays the words “Type a command” in a box (see Figure 1.4, earlier in this chapter). This tells you that AutoCAD is waiting for a command. When you click a point in the drawing area, you see the message `Specify opposite corner or [Fence/WPolygon/CPolygon]:`. At the same time, the cursor starts to draw a window selection that disappears when you click another point. The same message appears in the Dynamic Input display at the cursor.

As a new user, pay special attention to messages displayed in the Command window and the Dynamic Input display because this is how AutoCAD communicates with you. Besides giving you messages, the Command window records your activity within AutoCAD. You can use the scroll bar to the right of the Command window to review previous messages. You can also enlarge the window for a better view. (Chapter 2 discusses these components in more detail.)

Now let's look at the AutoCAD window components in detail.

THE COMMAND WINDOW AND DYNAMIC INPUT DISPLAY

The Command window and the Dynamic Input display allow AutoCAD to provide text feedback on your actions. You can think of these features as a chat window for communicating with AutoCAD—as you enter commands, AutoCAD responds with messages. As you become more familiar with AutoCAD, you may find that you don't need to rely on the Command window and Dynamic Input display as much. For new and casual users, however, the Command window and Dynamic Input display can be helpful in understanding what steps to take as you work.

Working with AutoCAD

Now that you've been introduced to the AutoCAD interface, you're ready to try using a few AutoCAD commands. First you'll open a sample file and make a few modifications to it. In the process, you'll become familiar with common methods of operation in AutoCAD.

Opening an Existing File

In this exercise, you'll get a chance to see and use a typical Select File dialog box.

Before you start, make sure that you have installed the sample files for this book from the book's web page. See the introduction for instructions on how to find the sample files.

To start, you'll open an existing file:



1. In the Drawing tab at the top left of the drawing area, click the Close icon to the far right of the tab.

A message appears, asking whether you want to save the changes you've made to the current drawing. Click No.



2. In the Start tab, click the Open Files option just below the Start Drawing icon in the left column.

The Select File dialog box opens. This is a typical Windows file dialog box with an added twist: In the large Preview box on the right, you can preview a drawing before you open it, thereby saving time while searching for files. To the left is a panel known as the Places list, in which you can find frequently used locations on your computer or the Internet (see Figure 1.14).

If you don't see a Preview box in the Select File dialog box, click the word *Views* in the upper-right corner and select Preview from the list that appears. Note that the Select File dialog box can be resized if you need to view more of your drawing list.

Figure 1.14
The Select File dialog box

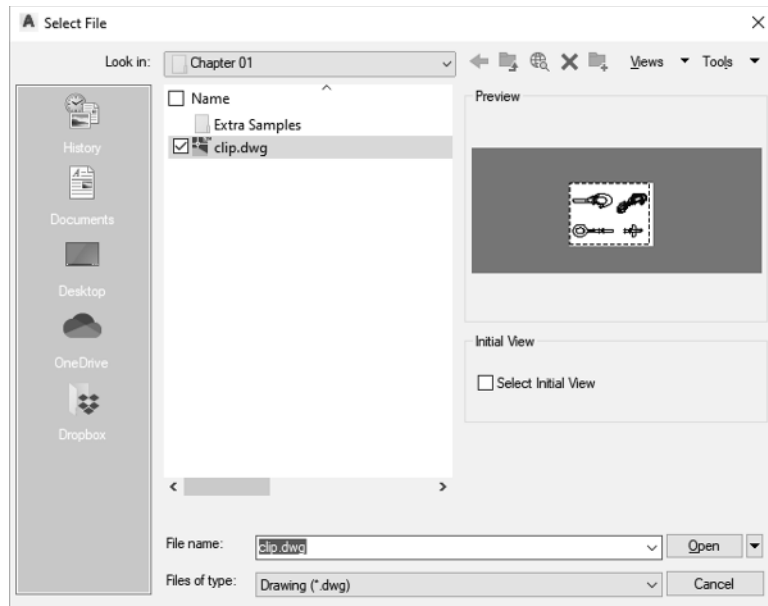

3. In the Select File dialog box, open the Look In drop-down list and locate the Chapter 1 folder of the Mastering AutoCAD 2019 sample files. (You may need to scroll through the list to find it.)
4. Move the arrow cursor to the clip.dwg file and click it.

Notice that the clip.dwg filename now appears in the File Name text box below the file list. The Preview box also now shows a thumbnail image of the file. Be aware that a thumbnail may not show for files from older versions of AutoCAD.

5. Click the Open button at the bottom of the Select File dialog box. AutoCAD opens the clip.dwg file, as shown in Figure 1.15.

The clip.dwg file opens to display a *layout* view of the drawing. A layout is a type of view in which you lay out different views of your drawing in preparation for printing. You can tell you are in a layout view by the white area bordered by a gray background. This white area represents your drawing on a printed page. This view is like a print preview.

Also note that the AutoCAD window's title bar displays the name of the drawing. The name is also displayed in the Drawing tab. This offers easy identification of the file.

This particular file contains both 2D drawings and a 3D model of a typical locking clip. The layout view shows top, front, and right-side views as well as an isometric view.

Getting a Closer Look

One of the most frequently used commands is Zoom, which gives you a closer look at part of your drawing. This command offers a variety of ways to control your view. In this section, you'll enlarge a portion of the clip drawing to get a more detailed look. You use a *zoom window* to tell AutoCAD which area you want to enlarge.

Figure 1.15

The Layout1 view of the clip.dwg file

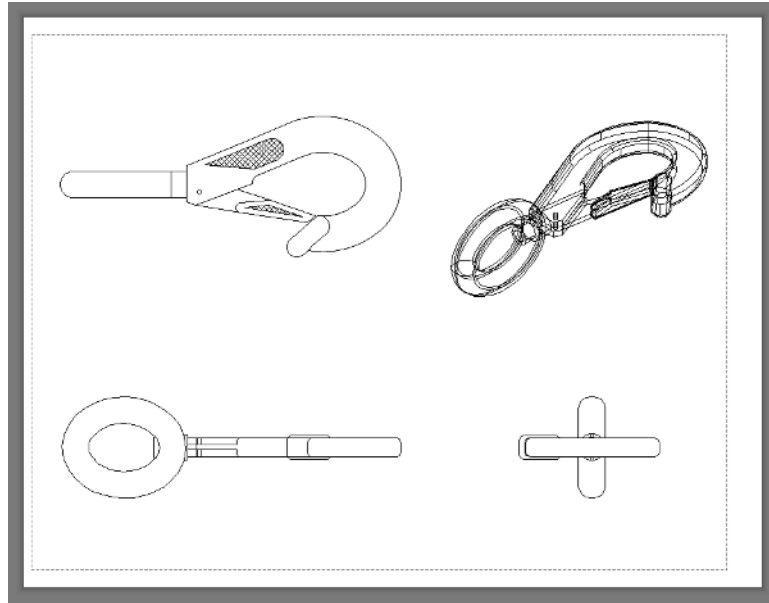

You'll start by switching to a model space view of the drawing. The model space view places you in a workspace where you do most of your drawing creation and editing. Follow these steps:

1. Hover over the Clip tab at the top left of the drawing area (see the left panel in Figure 1.16).

You'll see two preview icons showing the model space on the left and the layout space on the right. If you hover over the model space image, the drawing area will temporarily change to show you the full view of the model space.

Figure 1.16

Hover over the Drawing tab, and click the model space image (left).

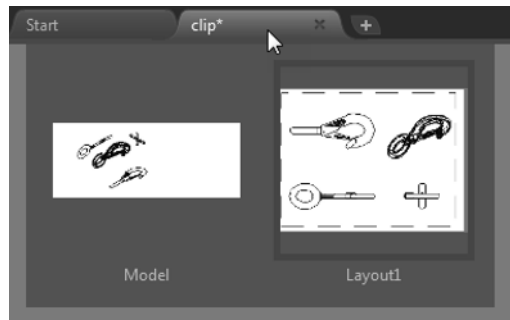

2. Click the image on the left showing the model space (see Figure 1.16).

Your view changes to show the full 3D model with the 2D representations of the model (see Figure 1.17). You can also click the Model tab below the drawing area (see the right panel in Figure 1.16) to accomplish the same change from the layout space to the model space.

Figure 1.17
3D model with 2D
representations
of the model

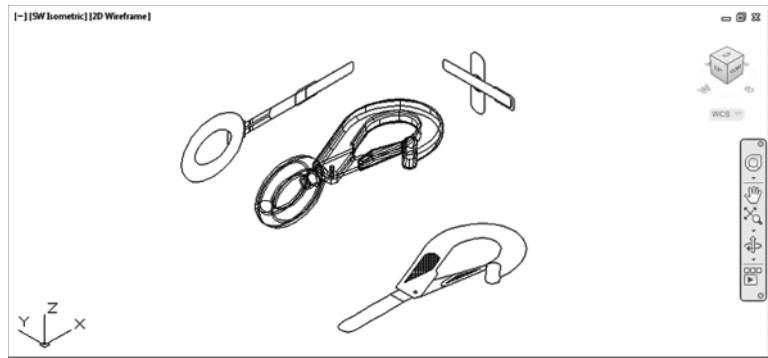

3. Type **PLAN**↵↵.

Your display changes to a two-dimensional view looking down on the drawing, as shown in Figure 1.18.

Figure 1.18
Placing the zoom
window around the clip

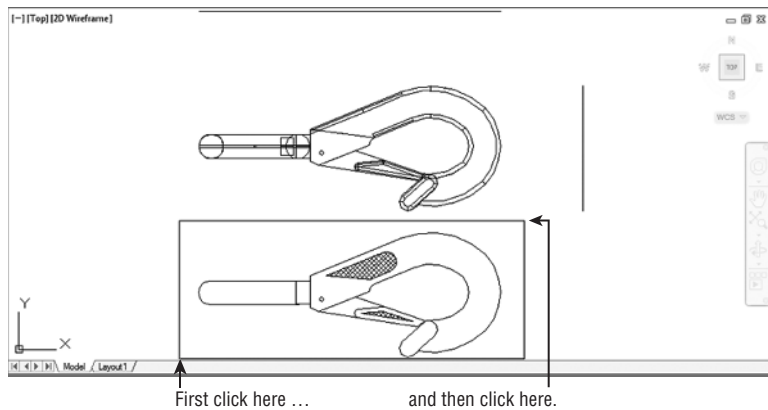

4. Click the Zoom Window tool from the Zoom flyout in the Navigation bar (see Figure 1.19). Remember that to open the flyout, you need to click the arrowhead next to or below the tool.

You can also click the Window tool from the Zoom flyout in the View tab's Navigate panel (see Figure 1.20) or type the command **Z**↵**W**↵. If you don't see the Navigate panel, right-click in the Ribbon and choose Show Panels > Navigate.

The Dynamic Input display shows the Specify first corner: prompt. (Look at the image in Figure 1.18.)

- 5.** Move the crosshair cursor to a location similar to the one shown in the figure labeled "First click here" and then left-click.
- 6.** Move the cursor, and the rectangle appears with one corner fixed on the point you just picked; the other corner follows the cursor.

The Dynamic Input display now shows the Specify opposite corner: prompt.

Figure 1.19

Choosing the Zoom Window tool from the Zoom flyout in the Navigation bar

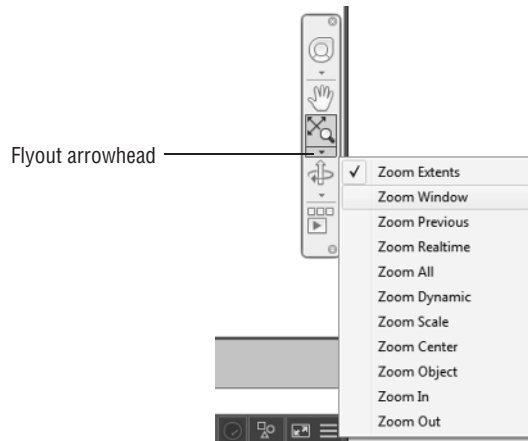
**Figure 1.20**

The Zoom flyout and Window tool in the View tab's Navigate panel

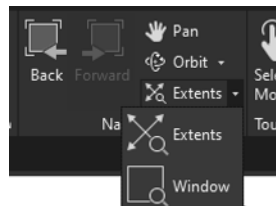

7. Position the other corner of the zoom window so that it encloses the lower image of the clip, as shown in Figure 1.18, and left-click the mouse again. The clip enlarges to fill the screen.

In this exercise, you used the Window option of the Zoom command to define an area to enlarge for your close-up view. You saw how AutoCAD prompts you to indicate first one corner of the window selection and then the other. These messages are helpful for first-time users of AutoCAD. You'll use the Window option frequently—not just to define views but also to select objects for editing.

Getting a close-up view of your drawing is crucial to working accurately, but you'll often want to return to a previous view to get the overall picture. To do so, choose Zoom Previous from the Zoom flyout in the Navigation bar (see Figure 1.21). You may also type `Z↵P↵`.

Figure 1.21

The Zoom Previous option



Do this now and the previous view appears. Click Zoom Previous again, and the view showing the entire clip returns to the screen.

You can quickly enlarge or reduce your view by using the Zoom Realtime option of the Zoom command. Follow these steps to change your view with Zoom Realtime:

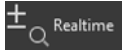

1. Click the Zoom Realtime option from the Navigation bar's Zoom flyout. You can also type **Z↵**.
2. Place the Zoom Realtime cursor slightly above the center of the drawing area and then click and drag downward. Your view zooms out to show more of the drawing.
3. While still holding the left mouse button, move the cursor upward. Your view zooms in and enlarges.
4. When you have a view similar to the one shown in Figure 1.22, release the mouse button.

Don't worry if you don't get *exactly* the same view as the figure. This is just for practice.

Figure 1.22

The final view you want to achieve in step 3 of the exercise

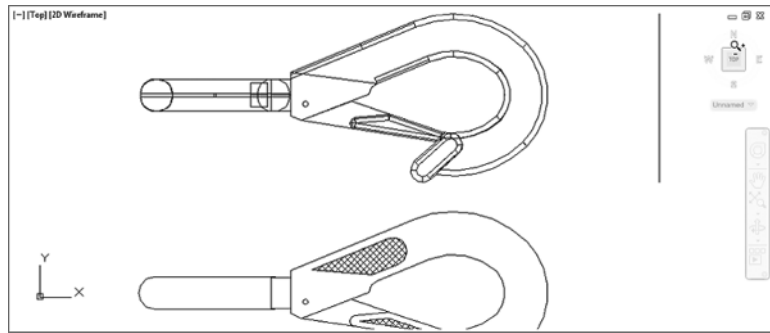

5. You're still in Zoom Realtime mode. Click and drag the mouse again to see how you can further adjust your view.
6. To exit, either select another command besides Zoom or Pan or press the Esc key twice.

If you prefer, you can use the wheel on your mouse to zoom and pan over your view. Roll the wheel to zoom in and out, or click and drag the wheel to pan. Be aware that Zoom Realtime offers finer control over the amount of magnification than does the mouse wheel.

As you can see from this exercise, you have a wide range of options for viewing your drawings just by using a few tools. These tools are all you need to control the display of 2D drawings.

Saving a File as You Work

It's a good idea to save your file periodically as you work on it. As with any Windows program, you can save it under its original name (click the Save tool on the Quick Access toolbar) or under a different name (choose Save As from the Application menu or the Quick Access toolbar), thereby creating a new file.

By default, AutoCAD automatically saves your work at 10-minute intervals under a name that is a combination of the current filename plus a number and that ends with the `.sv$` filename extension. This is known as the *Automatic Save* feature. Using settings in the Options dialog box or system variables, you can change the name of the autosaved file and control the time between autosaves or, for the reckless, disable it entirely. See "The Open And Save Tab" in Appendix B for details.

“I CAN’T FIND MY AUTOMATIC SAVES!”

AutoCAD’s Automatic Save feature places those files in this location by default: `C:\Users\USERNAME\appdata\local\temp\`. Different users on the same computer will have their files saved in a unique folder. You can find the exact location for your system by typing **Savefilepath**↵ at the Command prompt.

This file location is often set as a hidden folder, so you may need to set up Windows Explorer to display hidden folders before you can get to the Automatic Save file. You can also specify a different location for the Automatic Save files. See Appendix B for information on how to locate hidden files and specify a location for your files.

Making Changes

You’ll frequently make changes to your drawings. One of the primary advantages of AutoCAD is the ease with which you can make modifications. The following exercise shows you a typical sequence of operations involved in changing a drawing:

1. Use the Save As option in the Application menu to save the current `clip.dwg` file under the name **MyFirst**. For convenience, you can save your files in the My Documents folder.
2. From the Home tab’s Modify panel, click the Erase tool.



Notice that the cursor has turned into a small square. This square is called the *pickbox*. You also see **Select objects:** in the Command window and the Dynamic Input display. This message helps remind new users what to do.

3. Move the pickbox over the drawing, placing it on various parts of the clip. Don’t click anything yet.

Notice that as you hover your cursor over objects with the pickbox, they’re grayed out and a red X appears by the cursor. This helps you see the objects that the pickbox will select and erase should you click the left mouse button.

4. Place the pickbox on the crosshatch pattern of the clip (see Figure 1.23) and click.

The crosshatch turns a light gray. The pickbox and the **Select objects:** prompt remain, indicating that you can continue to select objects.

Figure 1.23
Erasing a portion
of the clip

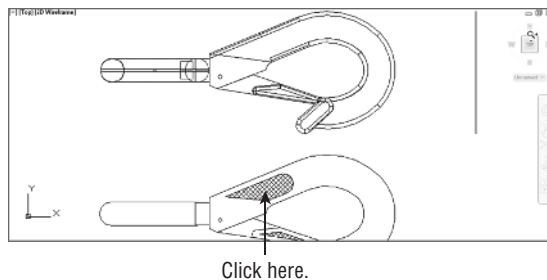

5. Press ↵. The crosshatch disappears. You’ve just erased a part of the drawing.

In this exercise, first you issued the Erase command, and then you selected an object by using a pickbox to click it. The pickbox tells you that you must select items on the screen, and it shows you what you're about to select by highlighting objects as you hover the cursor over them. Once you've clicked an object or a set of objects, press \leftarrow to move on to the next step. This sequence of steps is common to many of the commands you'll work with in AutoCAD.

You can also click an object or a set of objects and then press the Delete key.

Working with Multiple Files

You can have multiple documents open at the same time in AutoCAD. This feature can be especially helpful if you want to exchange parts of drawings between files or if you want another file open for reference. Try the following exercise to see how multiple documents work in AutoCAD:

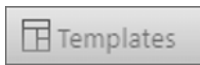

1. In the Start tab, locate the Templates option at the bottom of the Start Drawing icon and click it (see Figure 1.24).

Figure 1.24

Click the Templates option below the Start Drawing icon.



2. Select `acad.dwt` from the drop-down list.
3. Go to the Ribbon and, in the View tab's Interface panel, click Tile Vertically to get a view of both drawing files and the Start tab.
4. Click the minimize button in the upper-right corner of the Start tab window and then click Tile Vertically in the Interface panel again to get a better view of the two drawings.

When you create a new file in AutoCAD, you're actually opening a copy of a *template file*, as you saw in step 1. A template file is a blank file that is set up for specific drawing types. The `acad.dwt` file is a generic template set up for Imperial measurements. Another template file, called `acadiso.dwt`, is a generic template useful for metric measurements. Other templates are set up for specific drawing-sheet sizes and measurement systems. You'll learn more about templates in Chapter 6, "Editing and Reusing Data to Work Efficiently."

Next let's try drawing a rectangle to see how AutoCAD behaves while drawing objects:



1. Making sure that you have the newly created drawing as the active window, click the Rectangle tool in the Home tab's Draw panel, as shown in Figure 1.25.

Figure 1.25

Click the Rectangle tool in the Draw panel.

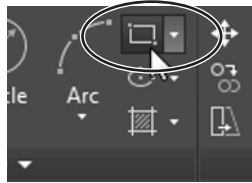

Notice that the Command window now shows the following prompt:

```
Specify first corner point or
[Chamfer/Elevation/Fillet/Thickness/Width]:
```

AutoCAD is asking you to select the first corner for the rectangle, and in brackets, it's offering a few options of which you can take advantage at this point in the command. Don't worry about those options right now. You'll have an opportunity to learn about command options in Chapter 2. You also see the same prompt, minus the bracketed options, in the Dynamic Input display at the cursor. You can view the command options at the cursor by pressing the down arrow key on your keyboard.

2. Click a point roughly in the lower-left corner of the drawing area, as shown in Figure 1.26. Now as you move your mouse, a rectangle follows the cursor, with one corner fixed at the position you just selected.

You also see the following prompt in the Command window, with a similar prompt in the Dynamic Input display:

```
Specify other corner point or [Area/Dimensions/Rotation]:
```

3. Click another point anywhere in the upper-right region of the drawing area, but avoid getting too close to the ViewCube (see Figure 1.27). A rectangle appears.
4. If you happen to accidentally open the ViewCube context menu, press Escape once and you will be able to position the corner.

You'll learn more about the different cursor shapes and what they mean in Chapter 2.

Let's try copying objects between these two files.

5. Click in the window with the clip drawing to make it active.
6. Click Zoom All from the Zoom flyout of the Navigation bar to get an overall view of the drawing (see Figure 1.28). You can also double-click the scroll wheel on your mouse to perform a Zoom Extents, which is similar to Zoom All.

Figure 1.26
Selecting the first point
of a rectangle

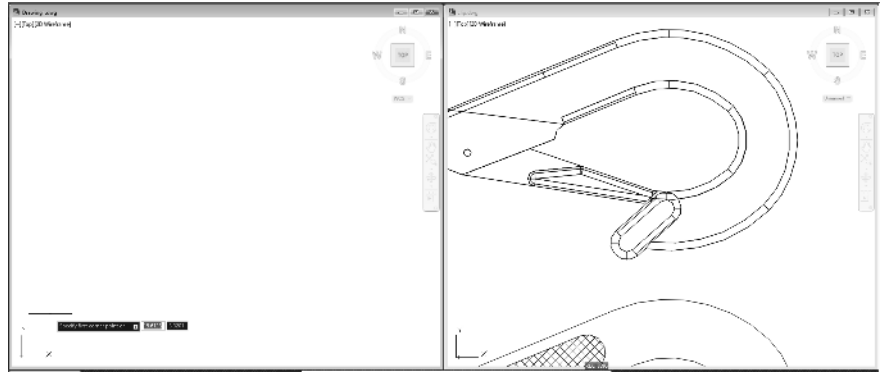

Figure 1.27
After you've selected the
first point of the
rectangle, you'll see a
rectangle follow the
motion of your mouse.

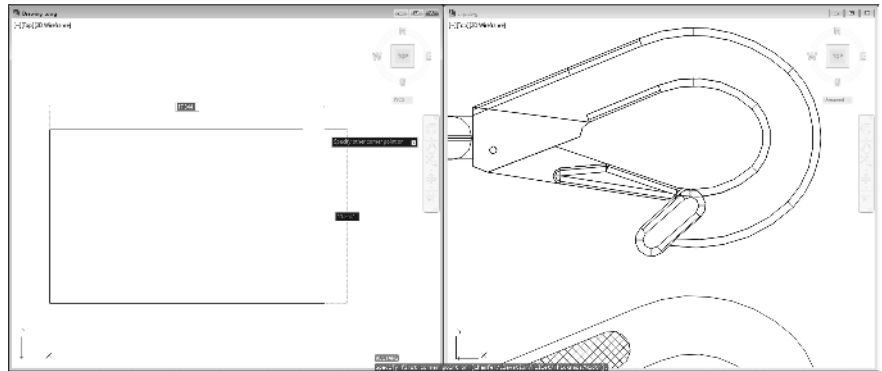
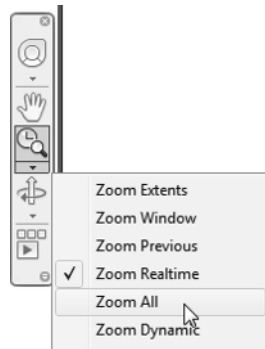

Figure 1.28

The Zoom All option gives you an overall view of your drawing.



7. Click the 2D version of the clip at the bottom of the drawing to select it.

A dot appears at the center of the clip, and a rectangle encloses it. You may find that some parts of the drawing within the rectangle have not been highlighted. If this happens, just click them in addition to the main clip drawing. The dot is called a *grip*; you'll learn more about grips in the next chapter (see Figure 1.29).

Figure 1.29

Grip shown in the 2D drawing

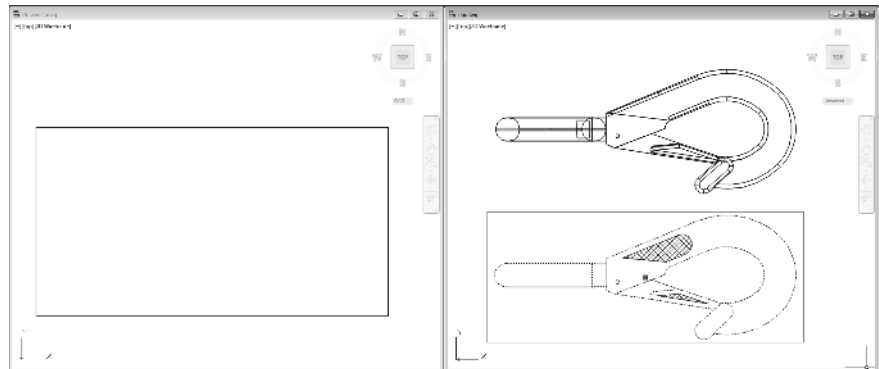

8. Right-click, select Clipboard, and then select Copy. You can also press Ctrl+C to invoke the Windows Copy To Clipboard shortcut.
9. Click inside the other drawing window to make it active.
10. Right-click, select Clipboard, and then select Paste. You can also press Ctrl+V to invoke the Windows Paste From Clipboard shortcut. The Specify Insertion Point prompt appears.

11. Click inside the rectangle. The clip appears at the cursor in the new drawing.
12. Save your `myfirst.dwg` file for future reference.

You can close the new drawing without saving it. You may have to maximize the Start tab, which will still be minimized at the bottom of the screen. This ends the exercises for this chapter.

LOSE THE NAVIGATION BAR?

If for some reason the Navigation bar is not visible, you can find it on the View tab's Viewport Tools panel. Click the Navigation Bar tool. The tool will highlight in blue, and the Navigation bar will appear. You can also type `Navbar` at the command line and choose one of the two options (On/Off). This panel also shows the tool to display the UCS icon and ViewCube if they also get misplaced.

Note that you've had two files open at once. You can have as many files open as you want as long as your computer has adequate memory to accommodate them. Also note that having larger files opened could affect performance, as well as files with images in them. You can control the individual document windows as you would any window, using the window control buttons in the upper-right corner of the drawing area.

Adding a Predrawn Symbol with the Tool Palettes

In the preceding exercise, you saw how you could easily copy an object from one file to another by using the standard Windows Cut and Paste feature. AutoCAD offers several tool palettes that enable you to click and drag predrawn objects into your drawing.

You can open the tool palettes by clicking the Tool Palettes button on the View tab's Palettes panel, as shown in Figure 1.30.

Figure 1.30
Open the Tool Palettes tool from the View tab.

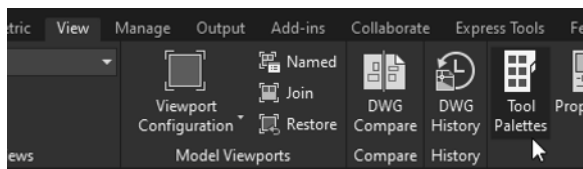

Once the tool palettes are open, you can select a tab containing the predrawn objects you want to use and then click the specific object you want to add. The object appears at the cursor, ready for you to select a location (see Figure 1.31).

Figure 1.31

The tool palettes offer predrawn symbols that you can easily place in your drawings.

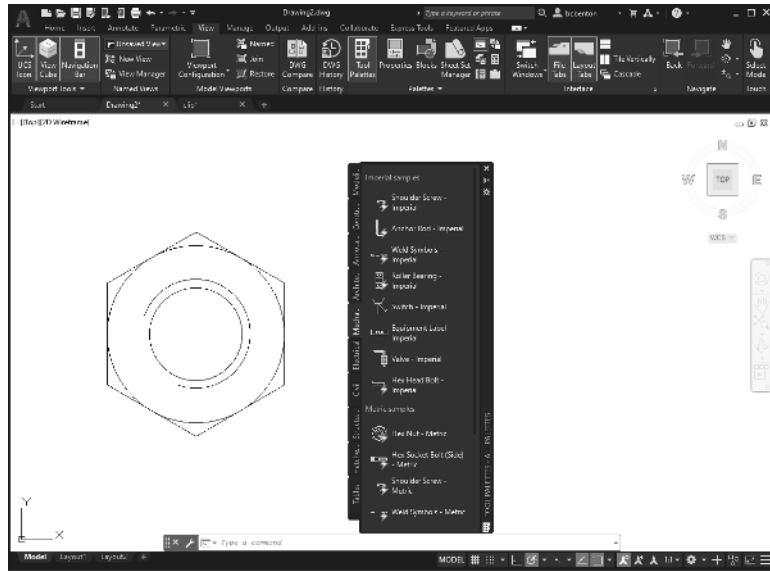

In addition to predrawn objects, the tool palettes offer a way to add hatch patterns and other components quickly to your drawing. They're great tools to help you manage your library of custom, predrawn symbols. Chapter 25, "Managing and Sharing Your Drawings," shows you how to use and customize the tool palettes.

CAN'T FIND THE TOOL OR PANEL WE'RE DISCUSSING?

The AutoCAD interface is easy to customize, and sometimes tools and options are hidden from view due to changes other users have made or as a result of changes from our review software to the final release version. If you don't see a tool or icon we're asking you to use in this or other chapters, here are a few places to check:

Quick Access Toolbar If you don't see an icon in the Quick Access toolbar, you can click the Customize Quick Access Toolbar drop-down arrow at the right end of the toolbar to open a list of additional Quick Access toolbar options.



Options that already appear in the toolbar show a check mark next to their name in the menu. Click the option that you want to have visible in the toolbar to make it visible. Clicking an option that shows a check mark will hide that option from the toolbar.

Status Bar Items missing from the status bar can be found by clicking the Customization tool in the lower-right corner of the AutoCAD window.



This opens a menu of tools that can be added to the status bar. Just as with the Quick Access toolbar, items that already appear in the status bar will display a check mark in the menu next to their name. If you need to check and uncheck multiple options, you can turn on the Lock UI option in the list. Lock UI keeps the menu open after you make a selection.

Ribbon If a Ribbon panel or Ribbon tab is missing, you can right-click in the Ribbon panel to open a menu that offers a list of available panels and tabs.

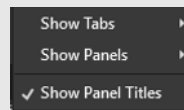

If you select the Show Tabs option, you will see a list of all of the tabs that are available for the current workspace. If you select the Show Panels option, you will see a list of panels that are available for the current Ribbon tab.

USC Icon, ViewCube, and Navigation Bar Some of the more useful panels in the AutoCAD interface can be turned on and off through tools in the Ribbon. The UCS icon, ViewCube, and Navigation bar can be controlled through tools in the View tab's Viewport Tools panel.



Reset AutoCAD to the Default Settings Finally, if your version of AutoCAD looks completely different from what you see here, you can reset your AutoCAD profile to the default settings:

1. Type **OPTIONS** ↵.
2. In the Options dialog box, select the Profiles tab at the upper right.
3. Click the Reset button in the right-hand column.
4. Click OK to exit the Options dialog box.

See “The Profiles Tab” in Appendix B for more information on how to save and restore the way AutoCAD is set up. Note that AutoCAD LT 2021 does not have a Profiles tab.

The Bottom Line

Use the AutoCAD® window. AutoCAD® is a typical Windows graphics program that makes use of menus, toolbars, Ribbon panels, and palettes. If you've used other Windows programs, you'll see at least a few familiar tools.

Master It Name the components of the AutoCAD interface that you can use to select a function.

Get a closer look with the Zoom command. One of the first things that you'll want to learn is how to manipulate your views. The Zoom command is a common tool in graphics programs.

Master It Name at least two ways of zooming into a view.

Save a file as you work. Nothing is more frustrating than having a network connection issue that causes you to lose hours of work. It's a good idea to save your work frequently. AutoCAD offers an Automatic Save feature that can be a lifesaver if you happen to forget to save your files.

Master It How often does the AutoCAD Automatic Save feature save your drawing?

Make changes and open multiple files. AutoCAD, similarly to other programs, can operate with multiple files opened simultaneously.

Master It With two drawings open, how can you copy parts of one drawing into the other?

