



The animation techniques and special effects used in the film *Avengers: Infinity War* rely on computers and mathematical concepts such as trigonometry and vectors. Such mathematical concepts will be useful throughout this book in our discussion of physics.

Lifestyle pictures/Alamy Stock Photo

Introduction and Mathematical Concepts

1.1 The Nature of Physics

Physics is the most basic of the sciences, and it is at the very root of subjects like chemistry, engineering, astronomy, and even biology. The discipline of physics has developed over many centuries, and it continues to evolve. It is a mature science, and its laws encompass a wide scope of phenomena that range from the formation of galaxies to the interactions of particles in the nuclei of atoms. Perhaps the most visible evidence of physics in everyday life is the eruption of new applications that have improved our quality of life, such as new medical devices, and advances in computers and high-tech communications.

The exciting feature of physics is its capacity for predicting how nature will behave in one situation on the basis of experimental data obtained in another situation. Such predictions place physics at the heart of modern technology and, therefore, can have a tremendous

LEARNING OBJECTIVES

After reading this module, you should be able to...

- 1.1** Describe the fundamental nature of physics.
- 1.2** Describe different systems of units.
- 1.3** Solve unit conversion problems.
- 1.4** Solve trigonometry problems.
- 1.5** Distinguish between vectors and scalars.
- 1.6** Solve vector addition and subtraction problems by graphical methods.
- 1.7** Calculate vector components.
- 1.8** Solve vector addition and subtraction problems using components.

impact on our lives. Rocketry and the development of space travel have their roots firmly planted in the physical laws of Galileo Galilei (1564–1642) and Isaac Newton (1642–1727). The transportation industry relies heavily on physics in the development of engines and the design of aerodynamic vehicles. Entire electronics and computer industries owe their existence to the invention of the transistor, which grew directly out of the laws of physics that describe the electrical behaviors of solids. The telecommunications industry depends extensively on electromagnetic waves, whose existence was predicted by James Clerk Maxwell (1831–1879) in his theory of electricity and magnetism. The medical profession uses X-ray, ultrasonic, and magnetic resonance methods for obtaining images of the interior of the human body, and physics lies at the core of all of these. Perhaps the most widespread impact in modern technology is that due to the laser. Fields ranging from space exploration to medicine benefit from this incredible device, which is a direct application of the principles of atomic physics.

Because physics is so fundamental, it is a required course for students in a wide range of major areas. We welcome you to the study of this fascinating topic. You will learn how to see the world through the “eyes” of physics and to reason as a physicist does. In the process, you will learn how to apply physics principles to a wide range of problems. We hope that you will come to recognize that physics has important things to say about your environment.

1.2 Units

Physics experiments involve the measurement of a variety of quantities, and a great deal of effort goes into making these measurements as accurate and reproducible as possible. The first step toward ensuring accuracy and reproducibility is defining the units in which the measurements are made.

In this text, we emphasize the system of units known as **SI units**, which stands for the French phrase “Le Système International d’Unités.” By international agreement, this system employs the **meter** (m) as the unit of length, the **kilogram** (kg) as the unit of mass, and the **second** (s) as the unit of time. Two other systems of units are also in use, however. The CGS system utilizes the centimeter (cm), the gram (g), and the second for length, mass, and time, respectively, and the BE or British Engineering system (the gravitational version) uses the foot (ft), the slug (sl), and the second. **Table 1.1** summarizes the units used for length, mass, and time in the three systems.

Originally, the meter was defined in terms of the distance measured along the earth’s surface between the north pole and the equator. Eventually, a more accurate measurement standard was needed, and by international agreement the meter became the distance between two marks on a bar of platinum–iridium alloy (see **Figure 1.1**) kept at a temperature of 0 °C. Today, to meet further demands for increased accuracy, the meter is defined as the distance that light travels in a vacuum in a time of 1/299 792 458 second. This definition arises because the speed of light is a universal constant that is defined to be 299 792 458 m/s.

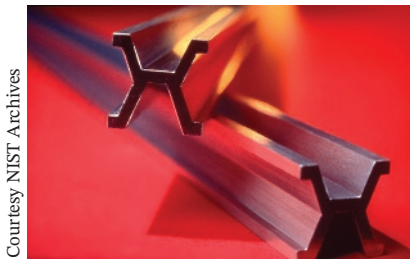

Courtesy NIST Archives

FIGURE 1.1 The standard platinum–iridium meter bar.

TABLE 1.1 Units of Measurement

	System		
	SI	CGS	BE
Length	Meter (m)	Centimeter (cm)	Foot (ft)
Mass	Kilogram (kg)	Gram (g)	Slug (sl)
Time	Second (s)	Second (s)	Second (s)

The definition of a kilogram as a unit of mass has also undergone changes over the years. As Chapter 4 discusses, the mass of an object indicates the tendency of the object to continue in motion with a constant velocity. Originally, the kilogram was expressed in terms of a specific amount of water. Since 1879, and until very recently, one kilogram was defined to be the mass of a standard cylinder of platinum–iridium alloy, like the one in **Figure 1.2**. Currently, one kilogram is defined in terms of two other **base** units (see below)—the meter and the second, which are based on fixed fundamental constants of nature. The kilogram is defined by setting Planck’s constant h exactly equal to $6.62607015 \times 10^{-34} \text{ J} \cdot \text{s}$. We will see in Section 29.2 that Planck’s constant is important in the field of quantum mechanics. This new definition of the kilogram took effect on May 20, 2019.

As with the units for length and mass, the present definition of the second as a unit of time is different from the original definition. Originally, the second was defined according to the average time for the earth to rotate once about its axis, one day being set equal to 86 400 seconds. The earth’s rotational motion was chosen because it is naturally repetitive, occurring over and over again. Today, we still use a naturally occurring repetitive phenomenon to define the second, but of a very different kind. We use the electromagnetic waves emitted by cesium-133 atoms in an atomic clock like that in **Figure 1.3**. One second is defined as the time needed for 9 192 631 770 wave cycles to occur.*

The units for length, mass, and time, along with a few other units that will arise later, are regarded as **base** SI units. The word “base” refers to the fact that these units are used along with various laws to define additional units for other important physical quantities, such as force and energy. The units for such other physical quantities are referred to as **derived** units, since they are combinations of the base units. Derived units will be introduced from time to time, as they arise naturally along with the related physical laws.

The value of a quantity in terms of base or derived units is sometimes a very large or very small number. In such cases, it is convenient to introduce larger or smaller units that are related to the normal units by multiples of ten. **Table 1.2** summarizes the prefixes that are used to denote multiples of ten. For example, 1000 or 10^3 meters are referred to as 1 kilometer (km), and 0.001 or 10^{-3} meter is called 1 millimeter (mm). Similarly, 1000 grams and 0.001 gram are referred to as 1 kilogram (kg) and 1 milligram (mg), respectively. Appendix A contains a discussion of scientific notation and powers of ten, such as 10^3 and 10^{-3} .

1.3 The Role of Units in Problem Solving

The Conversion of Units

Since any quantity, such as length, can be measured in several different units, it is important to know how to convert from one unit to another. For instance, the foot can be used to express the distance between the two marks on the standard platinum–iridium meter bar. There are 3.281 feet in one meter, and this number can be used to convert from meters to feet, as the following example demonstrates.

*See Chapter 16 for a discussion of waves in general and Chapter 24 for a discussion of electromagnetic waves in particular.

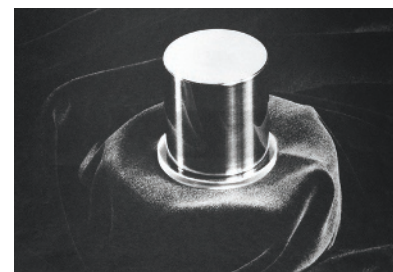

Science Source

FIGURE 1.2 The standard platinum–iridium kilogram is kept at the International Bureau of Weights and Measures in Sèvres, France. This copy of it was assigned to the United States in 1889 and is housed at the National Institute of Standards and Technology.

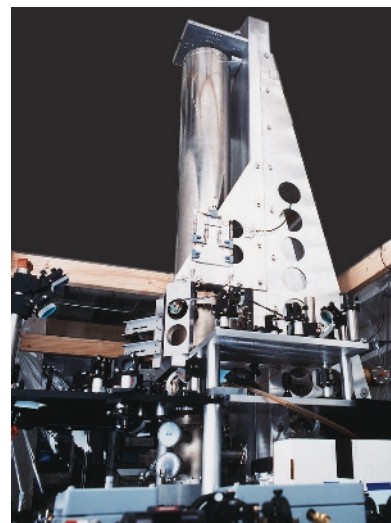

Geoffrey Wheeler

FIGURE 1.3 This atomic clock, the NIST-F1, keeps time with an uncertainty of about one second in sixty million years.

TABLE 1.2 Standard Prefixes Used to Denote Multiples of Ten

Prefix	Symbol	Factor ^a
tera	T	10^{12}
giga	G	10^9
mega	M	10^6
kilo	k	10^3
hecto	h	10^2
deka	da	10^1
deci	d	10^{-1}
centi	c	10^{-2}
milli	m	10^{-3}
micro	μ	10^{-6}
nano	n	10^{-9}
pico	p	10^{-12}
femto	f	10^{-15}

^aAppendix A contains a discussion of powers of ten and scientific notation.

EXAMPLE 1 | The World's Highest Waterfall

The highest waterfall in the world is Angel Falls in Venezuela, with a total drop of 979.0 m (see **Figure 1.4**). Express this drop in feet.

Reasoning When converting between units, we write down the units explicitly in the calculations and treat them like any algebraic quantity. In particular, we will take advantage of the following algebraic fact: Multiplying or dividing an equation by a factor of 1 does not alter an equation.

Solution Since 3.281 feet = 1 meter, it follows that $(3.281 \text{ feet}) / (1 \text{ meter}) = 1$. Using this factor of 1 to multiply the equation “Length = 979.0 meters,” we find that

$$\text{Length} = (979.0 \text{ m})(1) = (979.0 \text{ meters}) \left(\frac{3.281 \text{ feet}}{1 \text{ meter}} \right) = \boxed{3212 \text{ feet}}$$

The colored lines emphasize that the units of meters behave like any algebraic quantity and cancel when the multiplication is performed, leaving only the desired unit of feet to describe the answer. In this regard, note that 3.281 feet = 1 meter also implies that $(1 \text{ meter}) / (3.281 \text{ feet}) = 1$. However, we chose not to multiply by a factor of 1 in this form, because the units of meters would not have canceled.

A calculator gives the answer as 3212.099 feet. Standard procedures for significant figures, however, indicate that the answer should be rounded off to four significant figures, since the value of 979.0 meters is accurate to only four significant figures. In this regard, the “1 meter” in the denominator does not limit the significant figures of the answer, because this number is precisely one meter by definition of the conversion factor. Appendix B contains a review of significant figures.



Androni Canela/AGE Fotostock

FIGURE 1.4 Angel Falls in Venezuela is the highest waterfall in the world.

Problem-Solving Insight In any conversion, if the units do not combine algebraically to give the desired result, the conversion has not been carried out properly.

With this in mind, the next example stresses the importance of writing down the units and illustrates a typical situation in which several conversions are required.

EXAMPLE 2 | **BIO** The World's Fastest Land Animal

The cheetah can accelerate for a short time to a top speed of 75 miles/hour, making it the fastest animal on land (see **Figure 1.5**). Express 75 miles/hour in meters/second.

Reasoning As in Example 1, it is important to write down the units explicitly in the calculations and treat them like any

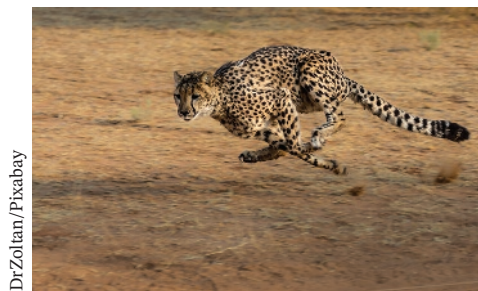

Dr.Zoltan/Pixabay

FIGURE 1.5 The cheetah is the world's fastest land animal.

algebraic quantity. Here, we take advantage of two well-known relationships—namely, 5280 feet = 1 mile and 3600 seconds = 1 hour. As a result, $(5280 \text{ feet}) / (1 \text{ mile}) = 1$ and $(3600 \text{ seconds}) / (1 \text{ hour}) = 1$. In our solution we will use the fact that multiplying and dividing by these factors of unity does not alter an equation.

Solution Multiplying and dividing by factors of unity, we find the cheetah's speed in feet per second as shown here:

$$\begin{aligned} \text{Speed} &= \left(75 \frac{\text{miles}}{\text{hour}} \right) (1)(1) = \\ &= \left(75 \frac{\text{miles}}{\text{hour}} \right) \left(\frac{5280 \text{ feet}}{1 \text{ mile}} \right) \left(\frac{1 \text{ hour}}{3600 \text{ seconds}} \right) = 110 \frac{\text{feet}}{\text{second}} \end{aligned}$$

To convert feet into meters, we use the fact that $(1 \text{ meter}) / (3.281 \text{ feet}) = 1$:

$$\begin{aligned} \text{Speed} &= \left(110 \frac{\text{feet}}{\text{second}} \right) (1) = \\ &= \left(110 \frac{\text{feet}}{\text{second}} \right) \left(\frac{1 \text{ meter}}{3.281 \text{ feet}} \right) = \boxed{34 \frac{\text{meters}}{\text{second}}} \end{aligned}$$

In addition to their role in guiding the use of conversion factors, units serve a useful purpose in solving problems. They can provide an internal check to eliminate errors, if they are carried along during each step of a calculation and treated like any algebraic factor.

Problem-Solving Insight In particular, remember that only quantities with the same units can be added or subtracted.

Thus, at one point in a calculation, if you find yourself adding 12 miles to 32 kilometers, stop and reconsider. Either miles must be converted into kilometers or kilometers must be converted into miles before the addition can be carried out. A collection of useful conversion factors is given on the page facing the inside of the front cover.

The reasoning strategy that we have followed in Examples 1 and 2 for converting between units is outlined as follows:

REASONING STRATEGY Converting Between Units

1. In all calculations, write down the units explicitly.
2. Treat all units as algebraic quantities. In particular, when identical units are divided, they are eliminated algebraically.
3. Use the conversion factors located on the page facing the inside of the front cover of the textbook. Be guided by the fact that multiplying or dividing an equation by a factor of 1 does not alter the equation. For instance, the conversion factor of 3.281 feet = 1 meter might be applied in the form $(3.281 \text{ feet})/(1 \text{ meter}) = 1$. This factor of 1 would be used to multiply an equation such as “Length = 5.00 meters” in order to convert meters to feet.
4. Check to see that your calculations are correct by verifying that the units combine algebraically to give the desired unit for the answer. Only quantities with the same units can be added or subtracted.

Sometimes an equation is expressed in a way that requires specific units to be used for the variables in the equation. In such cases it is important to understand why only certain units can be used in the equation, as the following example illustrates.

EXAMPLE 3 | **BIO** The Physics of the Body Mass Index

The body mass index (BMI) takes into account your mass in kilograms (kg) and your height in meters (m) and is defined as follows:

$$\text{BMI} = \frac{\text{Mass in kg}}{(\text{Height in m})^2}$$

However, the BMI is often computed using the weight* of a person in pounds (lb) and his or her height in inches (in.). Thus, the expression for the BMI incorporates these quantities, rather than the mass in kilograms and the height in meters. Starting with the definition above, determine the expression for the BMI that uses pounds and inches.

Reasoning We will begin with the BMI definition and work separately with the numerator and the denominator. We will determine the mass in kilograms that appears in the numerator from the weight in pounds by using the fact that 1 kg corresponds to 2.205 lb. Then, we will determine the height in meters that appears in the denominator from the height in inches with the aid of the facts that $1 \text{ m} = 3.281 \text{ ft}$ and $1 \text{ ft} = 12 \text{ in.}$ These conversion factors are located on the page facing the inside of the front cover of the text.

Solution Since 1 kg corresponds to 2.205 lb, the mass in kilograms can be determined from the weight in pounds in the following way:

$$\text{Mass in kg} = (\text{Weight in lb}) \left(\frac{1 \text{ kg}}{2.205 \text{ lb}} \right)$$

Since $1 \text{ ft} = 12 \text{ in.}$ and $1 \text{ m} = 3.281 \text{ ft}$, we have

$$\text{Height in m} = (\text{Height in in.}) \left(\frac{1 \text{ ft}}{12 \text{ in.}} \right) \left(\frac{1 \text{ m}}{3.281 \text{ ft}} \right)$$

Substituting these results into the numerator and denominator of the BMI definition gives

$$\begin{aligned} \text{BMI} &= \frac{\text{Mass in kg}}{(\text{Height in m})^2} = \frac{(\text{Weight in lb}) \left(\frac{1 \text{ kg}}{2.205 \text{ lb}} \right)}{(\text{Height in in.})^2 \left(\frac{1 \text{ ft}}{12 \text{ in.}} \right)^2 \left(\frac{1 \text{ m}}{3.281 \text{ ft}} \right)^2} \\ &= \left(\frac{1 \text{ kg}}{2.205 \text{ lb}} \right) \left(\frac{12 \text{ in.}}{1 \text{ ft}} \right)^2 \left(\frac{3.281 \text{ ft}}{1 \text{ m}} \right)^2 \frac{(\text{Weight in lb})}{(\text{Height in in.})^2} \end{aligned}$$

$$\text{BMI} = \left(703.0 \frac{\text{kg} \cdot \text{in.}^2}{\text{lb} \cdot \text{m}^2} \right) \frac{(\text{Weight in lb})}{(\text{Height in in.})^2}$$

For example, if your weight and height are 180 lb and 71 in., your body mass index is 25 kg/m^2 . The BMI can be used to assess approximately whether your weight is normal for your height (see [Table 1.3](#)).

TABLE 1.3 The Body Mass Index

BMI (kg/m^2)	Evaluation
Below 18.5	Underweight
18.5–24.9	Normal
25.0–29.9	Overweight
30.0–39.9	Obese
40 and above	Morbidly obese

*Weight and mass are different concepts, and the relationship between them will be discussed in Section 4.7.

Dimensional Analysis

We have seen that many quantities are denoted by specifying both a number and a unit. For example, the distance to the nearest telephone may be 8 meters, or the speed of a car might be 25 meters/second. Each quantity, according to its physical nature, requires a certain *type* of unit. Distance must be measured in a length unit such as meters, feet, or miles, and a time unit will not do. Likewise, the speed of an object must be specified as a length unit divided by a time unit. In physics, the term **dimension** is used to refer to the physical nature of a quantity and the type of unit used to specify it. Distance has the dimension of length, which is symbolized as [L], while speed has the dimensions of length [L] divided by time [T], or [L/T]. Many physical quantities can be expressed in terms of a combination of fundamental dimensions such as length [L], time [T], and mass [M]. Later on, we will encounter certain other quantities, such as temperature, which are also fundamental. A fundamental quantity like temperature cannot be expressed as a combination of the dimensions of length, time, mass, or any other fundamental dimension.

Dimensional analysis is used to check mathematical relations for the consistency of their dimensions. As an illustration, consider a car that starts from rest and accelerates to a speed v in a time t . Suppose we wish to calculate the distance x traveled by the car but are not sure whether the correct relation is $x = \frac{1}{2}vt^2$ or $x = \frac{1}{2}vt$. We can decide by checking the quantities on both sides of the equals sign to see whether they have the same dimensions. If the dimensions are not the same, the relation is incorrect. For $x = \frac{1}{2}vt^2$, we use the dimensions for distance [L], time [T], and speed [L/T] in the following way:

$$x = \frac{1}{2}vt^2$$

Dimensions

$$[L] \stackrel{?}{=} \left[\frac{L}{T}\right][T]^2 = [L][T]$$

Dimensions cancel just like algebraic quantities, and pure numerical factors like $\frac{1}{2}$ have no dimensions, so they can be ignored. The dimension on the left of the equals sign does not match those on the right, so the relation $x = \frac{1}{2}vt^2$ cannot be correct. On the other hand, applying dimensional analysis to $x = \frac{1}{2}vt$, we find that

$$x = \frac{1}{2}vt$$

Dimensions

$$[L] \stackrel{?}{=} \left[\frac{L}{T}\right][T] = [L]$$

Problem-Solving Insight You can check for errors that may have arisen during algebraic manipulations by performing a dimensional analysis on the final expression.

The dimension on the left of the equals sign matches that on the right, so this relation is dimensionally correct. If we know that one of our two choices is the right one, then $x = \frac{1}{2}vt$ is it. In the absence of such knowledge, however, dimensional analysis cannot identify the correct relation. It can only identify which choices *may be* correct, since it does not account for numerical factors like $\frac{1}{2}$ or for the manner in which an equation was derived from physics principles.

Check Your Understanding

(The answers are given at the end of the book.)

- (a) Is it possible for two quantities to have the same dimensions but different units?
(b) Is it possible for two quantities to have the same units but different dimensions?

2. You can always add two numbers that have the same units (such as 6 meters + 3 meters). Can you always add two numbers that have the same dimensions, such as two numbers that have the dimensions of length [L]?
3. The following table lists four variables, along with their units:

Variable	Units
x	Meters (m)
v	Meters per second (m/s)
t	Seconds (s)
a	Meters per second squared (m/s ²)

These variables appear in the following equations, along with a few numbers that have no units. In which of the equations are the units on the left side of the equals sign consistent with the units on the right side?

$$\begin{array}{ll} \text{(a)} \quad x = vt & \text{(d)} \quad v = at + \frac{1}{2}at^3 \\ \text{(b)} \quad x = vt + \frac{1}{2}at^2 & \text{(e)} \quad v^3 = 2ax^2 \\ \text{(c)} \quad v = at & \text{(f)} \quad t = \sqrt{\frac{2x}{a}} \end{array}$$

4. In the equation $y = c^n at^2$ you wish to determine the integer value (1, 2, etc.) of the exponent n . The dimensions of y , a , and t are known. It is also known that c has no dimensions. Can dimensional analysis be used to determine n ?

1.4 Trigonometry

Scientists use mathematics to help them describe how the physical universe works, and trigonometry is an important branch of mathematics. Three trigonometric functions are utilized throughout this text. They are the sine, the cosine, and the tangent of the angle θ (Greek theta), abbreviated as $\sin \theta$, $\cos \theta$, and $\tan \theta$, respectively. These functions are defined below in terms of the symbols given along with the right triangle in **Interactive Figure 1.6**.

DEFINITION OF SIN θ , COS θ , AND TAN θ

$$\sin \theta = \frac{h_o}{h} \quad (1.1)$$

$$\cos \theta = \frac{h_a}{h} \quad (1.2)$$

$$\tan \theta = \frac{h_o}{h_a} \quad (1.3)$$

h = length of the hypotenuse of a right triangle

h_o = length of the side opposite the angle θ

h_a = length of the side adjacent to the angle θ

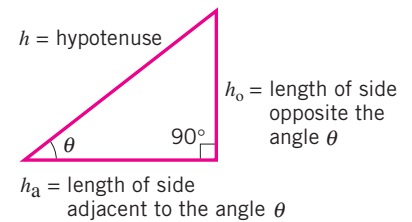

INTERACTIVE FIGURE 1.6 A right triangle.

The sine, cosine, and tangent of an angle are numbers without units, because each is the ratio of the lengths of two sides of a right triangle. Example 4 illustrates a typical application of Equation 1.3.

EXAMPLE 4 | Using Trigonometric Functions

On a sunny day, a tall building casts a shadow that is 67.2 m long. The angle between the sun's rays and the ground is $\theta = 50.0^\circ$, as **Figure 1.7** shows. Determine the height of the building.

Reasoning We want to find the height of the building. Therefore, we begin with the colored right triangle in **Figure 1.7** and identify the height as the length h_o of the side opposite the angle θ . The length of the shadow is the length h_a of the side that is adjacent to the angle θ . The ratio of the length of the opposite side to the length of the adjacent side is the tangent of the angle θ , which can be used to find the height of the building.

Solution We use the tangent function in the following way, with $\theta = 50.0^\circ$ and $h_a = 67.2$ m:

$$\tan \theta = \frac{h_o}{h_a} \quad (1.3)$$

$$h_o = h_a \tan \theta = (67.2 \text{ m})(\tan 50.0^\circ) = (67.2 \text{ m})(1.19) = \boxed{80.0 \text{ m}}$$

The value of $\tan 50.0^\circ$ is found by using a calculator.

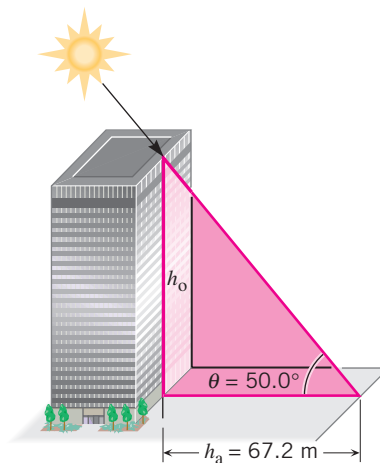

FIGURE 1.7 From a value for the angle θ and the length h_a of the shadow, the height h_o of the building can be found using trigonometry.

The sine, cosine, or tangent may be used in calculations such as that in Example 4, depending on which side of the triangle has a known value and which side is asked for.

Problem-Solving Insight However, the choice of which side of the triangle to label h_o (opposite) and which to label h_a (adjacent) can be made only after the angle θ is identified.

Often the values for two sides of the right triangle in **Interactive Figure 1.6** are available, and the value of the angle θ is unknown. The concept of **inverse trigonometric functions** plays an important role in such situations. Equations 1.4–1.6 give the inverse sine, inverse cosine, and inverse tangent in terms of the symbols used in the drawing. For instance, Equation 1.4 is read as “ θ equals the angle whose sine is h_o/h .”

$$\theta = \sin^{-1}\left(\frac{h_o}{h}\right) \quad (1.4)$$

$$\theta = \cos^{-1}\left(\frac{h_a}{h}\right) \quad (1.5)$$

$$\theta = \tan^{-1}\left(\frac{h_o}{h_a}\right) \quad (1.6)$$

The use of -1 as an exponent in Equations 1.4–1.6 *does not mean* “take the reciprocal.” For instance, $\tan^{-1}(h_o/h_a)$ does not equal $1/\tan(h_o/h_a)$. Another way to express the inverse trigonometric functions is to use arc sin, arc cos, and arc tan instead of \sin^{-1} , \cos^{-1} , and \tan^{-1} . Example 5 illustrates the use of an inverse trigonometric function.

EXAMPLE 5 | Using Inverse Trigonometric Functions

A lakefront drops off gradually at an angle θ , as **Figure 1.8** indicates. For safety reasons, it is necessary to know how deep the lake is at various distances from the shore. To provide some information about the depth, a lifeguard rows straight out from the shore a distance of 14.0 m and drops a weighted fishing line. By measuring the length of the line, the lifeguard determines the depth to be 2.25 m. **(a)** What is the value of θ ? **(b)** What would be the depth d of the lake at a distance of 22.0 m from the shore?

Reasoning Near the shore, the lengths of the opposite and adjacent sides of the right triangle in **Figure 1.8** are $h_o = 2.25$ m and $h_a = 14.0$ m, relative to the angle θ . Having made this identification, we can use the inverse tangent to find the angle in part (a). For part (b) the opposite and adjacent sides farther from the shore become $h_o = d$ and $h_a = 22.0$ m. With the value for θ obtained in part (a), the tangent function can be used to find the unknown depth. Considering the way in which the lake bottom

drops off in **Figure 1.8**, we expect the unknown depth to be greater than 2.25 m.

Solution (a) Using the inverse tangent given in Equation 1.6, we find that

$$\theta = \tan^{-1}\left(\frac{h_o}{h_a}\right) = \tan^{-1}\left(\frac{2.25 \text{ m}}{14.0 \text{ m}}\right) = \boxed{9.13^\circ}$$

(b) With $\theta = 9.13^\circ$, the tangent function given in Equation 1.3 can be used to find the unknown depth farther from the shore, where $h_o = d$ and $h_a = 22.0 \text{ m}$. Since $\tan \theta = h_o/h_a$, it follows that

$$h_o = h_a \tan \theta$$

$$d = (22.0 \text{ m})(\tan 9.13^\circ) = \boxed{3.54 \text{ m}}$$

which is greater than 2.25 m, as expected.

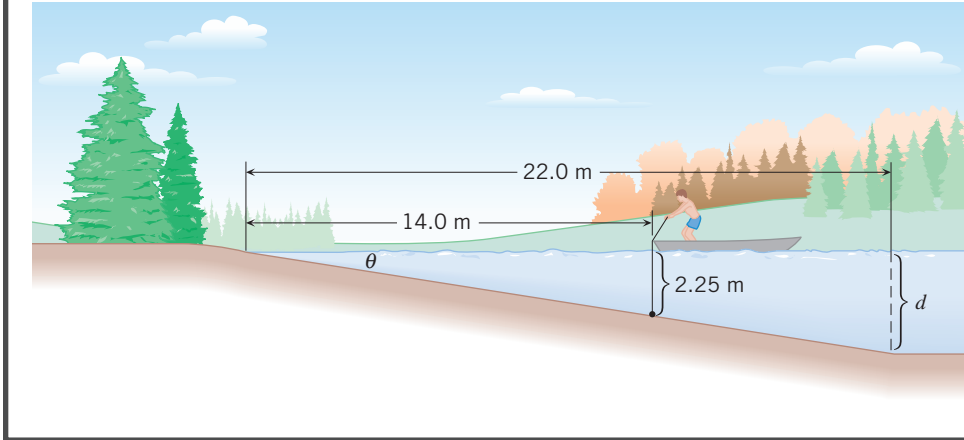

FIGURE 1.8 If the distance from the shore and the depth of the water at any one point are known, the angle θ can be found with the aid of trigonometry. Knowing the value of θ is useful, because then the depth d at another point can be determined.

The right triangle in **Interactive Figure 1.6** provides the basis for defining the various trigonometric functions according to Equations 1.1–1.3. These functions always involve an angle and two sides of the triangle. There is also a relationship among the lengths of the three sides of a right triangle. This relationship is known as the **Pythagorean theorem** and is used often in this text.

PYTHAGOREAN THEOREM

The square of the length of the hypotenuse of a right triangle is equal to the sum of the squares of the lengths of the other two sides:

$$h^2 = h_o^2 + h_a^2 \quad (1.7)$$

1.5 Scalars and Vectors

The volume of water in a swimming pool might be 50 cubic meters, or the winning time of a race could be 11.3 seconds. In cases like these, only the size of the numbers matters. In other words, *how much* volume or time is there? The 50 specifies the amount of water in units of cubic meters, while the 11.3 specifies the amount of time in seconds. Volume and time are examples of scalar quantities. A **scalar quantity** is one that can be described with a single number (including any units) giving its size or magnitude. Some other common scalars are temperature (e.g., 20°C) and mass (e.g., 85 kg).

While many quantities in physics are scalars, there are also many that are not, and for these quantities the magnitude tells only part of the story. Consider **Figure 1.9**, which depicts a car that has moved 2 km along a straight line from start to finish. When describing the motion, it is incomplete to say that “the car moved a distance of 2 km.” This statement would indicate only that the car ends up somewhere on a circle whose center is at the starting point and whose radius is 2 km. A complete description must include the direction along with the distance, as in the statement “the car moved a distance of 2 km in a direction 30° north of east.” A quantity that deals inherently with *both magnitude and direction* is called a **vector quantity**. Because direction is an important characteristic of vectors, arrows are used to represent them; *the direction of the arrow gives the direction of the vector*. The colored arrow in **Figure 1.9**, for example, is called the **displacement vector**, because it shows how the car is displaced from its starting point. Chapter 2 discusses this particular vector.

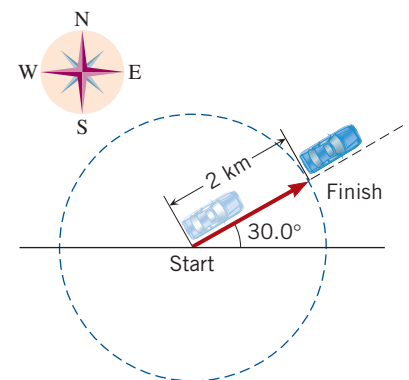

FIGURE 1.9 A vector quantity has a magnitude and a direction. The colored arrow in this drawing represents a displacement vector.

The length of the arrow in **Figure 1.9** represents the magnitude of the displacement vector. If the car had moved 4 km instead of 2 km from the starting point, the arrow would have been drawn twice as long. **By convention, the length of a vector arrow is proportional to the magnitude of the vector.**

In physics there are many important kinds of vectors, and the practice of using the length of an arrow to represent the magnitude of a vector applies to each of them. All forces, for instance, are vectors. In common usage a force is a push or a pull, and the direction in which a force acts is just as important as the strength or magnitude of the force. The magnitude of a force is measured in SI units called newtons (N). An arrow representing a force of 20 newtons is drawn twice as long as one representing a force of 10 newtons.

The fundamental distinction between scalars and vectors is the characteristic of direction. Vectors have it, and scalars do not. Conceptual Example 6 helps to clarify this distinction and explains what is meant by the “direction” of a vector.

CONCEPTUAL EXAMPLE 6 | Vectors, Scalars, and the Role of Plus and Minus Signs

There are places where the temperature is $+20\text{ }^{\circ}\text{C}$ at one time of the year and $-20\text{ }^{\circ}\text{C}$ at another time. Do the plus and minus signs that signify positive and negative temperatures imply that temperature is a vector quantity? **(a)** Yes **(b)** No

Reasoning A hallmark of a vector is that there is both a magnitude and a physical direction associated with it, such as 20 meters due east or 20 meters due west.

Answer (a) is incorrect. The plus and minus signs associated with $+20\text{ }^{\circ}\text{C}$ and $-20\text{ }^{\circ}\text{C}$ do not convey a physical direction, such as due east or due west. Therefore, temperature cannot be a vector quantity.

Answer (b) is correct. On a thermometer, the algebraic signs simply mean that the temperature is a number less than or greater than zero on the temperature scale being used and have nothing to do with east, west, or any other physical direction. Temperature, then, is not a vector. It is a scalar, and scalars can sometimes be negative.

Often, for the sake of convenience, quantities such as volume, time, displacement, velocity, and force are represented in physics by symbols. In this text, we write vectors in boldface symbols (**this is boldface**) with arrows above them* and write scalars in italic symbols (*this is italic*). Thus, a displacement vector is written as “ $\vec{\mathbf{A}} = 750\text{ m}$, due east,” where the $\vec{\mathbf{A}}$ is a boldface symbol. By itself, however, separated from the direction, the magnitude of this vector is a scalar quantity. Therefore, the magnitude is written as “ $A = 750\text{ m}$,” where the A is an italic symbol without an arrow.

Check Your Understanding

(The answer is given at the end of the book.)

5. Which of the following statements, if any, involves a vector? **(a)** I walked 2 miles along the beach. **(b)** I walked 2 miles due north along the beach. **(c)** I jumped off a cliff and hit the water traveling at 17 miles per hour. **(d)** I jumped off a cliff and hit the water traveling straight down at a speed of 17 miles per hour. **(e)** My bank account shows a negative balance of -25 dollars.

1.6

Vector Addition and Subtraction

Addition

Often it is necessary to add one vector to another, and the process of addition must take into account both the magnitude and the direction of the vectors. The simplest situation occurs when the vectors point along the same direction—that is, when they are colinear,

*Vectors are also sometimes written in other texts as boldface symbols without arrows above them.

as in **Figure 1.10**. Here, a car first moves along a straight line, with a displacement vector \vec{A} of 275 m, due east. Then the car moves again in the same direction, with a displacement vector \vec{B} of 125 m, due east. These two vectors add to give the total displacement vector \vec{R} , which would apply if the car had moved from start to finish in one step. The symbol \vec{R} is used because the total vector is often called the **resultant vector**. With the tail of the second arrow located at the head of the first arrow, the two lengths simply add to give the length of the total displacement. This kind of vector addition is identical to the familiar addition of two scalar numbers ($2 + 3 = 5$) and can be carried out here only because the vectors point along the same direction. In such cases we add the individual magnitudes to get the magnitude of the total, knowing in advance what the direction must be. Formally, the addition is written as follows:

$$\begin{aligned}\vec{R} &= \vec{A} + \vec{B} \\ \vec{R} &= 275 \text{ m, due east} + 125 \text{ m, due east} = 400 \text{ m, due east}\end{aligned}$$

Perpendicular vectors are frequently encountered, and **Figure 1.11** indicates how they can be added. This figure applies to a car that first travels with a displacement vector \vec{A} of 275 m, due east, and then with a displacement vector \vec{B} of 125 m, due north. The two vectors add to give a resultant displacement vector \vec{R} . Once again, the vectors to be added are arranged in a tail-to-head fashion, and the resultant vector points from the tail of the first to the head of the last vector added. The resultant displacement is given by the vector equation

$$\vec{R} = \vec{A} + \vec{B}$$

The addition in this equation cannot be carried out by writing $R = 275 \text{ m} + 125 \text{ m}$, because the vectors have different directions. Instead, we take advantage of the fact that the triangle in **Figure 1.11** is a right triangle and use the Pythagorean theorem (Equation 1.7). According to this theorem, the magnitude of \vec{R} is

$$R = \sqrt{(275 \text{ m})^2 + (125 \text{ m})^2} = 302 \text{ m}$$

The angle θ in **Figure 1.11** gives the direction of the resultant vector. Since the lengths of all three sides of the right triangle are now known, $\sin \theta$, $\cos \theta$, or $\tan \theta$ can be used to determine θ . Noting that $\tan \theta = B/A$ and using the inverse trigonometric function, we find that:

$$\theta = \tan^{-1}\left(\frac{B}{A}\right) = \tan^{-1}\left(\frac{125 \text{ m}}{275 \text{ m}}\right) = 24.4^\circ$$

Thus, the resultant displacement of the car has a magnitude of 302 m and points north of east at an angle of 24.4° . This displacement would bring the car from the start to the finish in **Figure 1.11** in a single straight-line step.

When two vectors to be added are not perpendicular, the tail-to-head arrangement does not lead to a right triangle, and the Pythagorean theorem cannot be used. **Figure 1.12a** illustrates such a case for a car that moves with a displacement \vec{A} of 275 m, due east, and then with a displacement \vec{B} of 125 m, in a direction 55.0° north of west. As usual, the resultant displacement vector \vec{R} is directed from the tail of the first to the head of the last vector added. The vector addition is still given according to

$$\vec{R} = \vec{A} + \vec{B}$$

However, the magnitude of \vec{R} is not $R = A + B$, because the vectors \vec{A} and \vec{B} do not have the same direction, and neither is it $R = \sqrt{A^2 + B^2}$, because the vectors are not perpendicular, so the Pythagorean theorem does not apply. Some other means must be used to find the magnitude and direction of the resultant vector.

One approach uses a graphical technique. In this method, a diagram is constructed in which the arrows are drawn tail to head. The lengths of the vector arrows are drawn to scale, and the angles are drawn accurately (with a protractor, perhaps). Then the length of the arrow representing the resultant vector is measured with a ruler. This length is converted to the magnitude of the resultant vector by using the scale factor with which

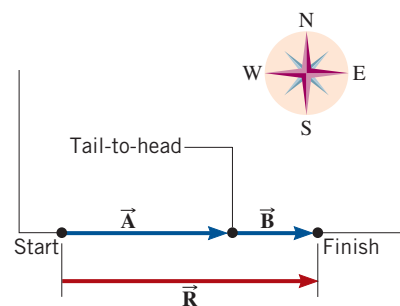

FIGURE 1.10 Two colinear displacement vectors \vec{A} and \vec{B} add to give the resultant displacement vector \vec{R} .

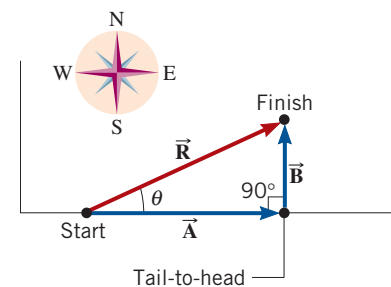
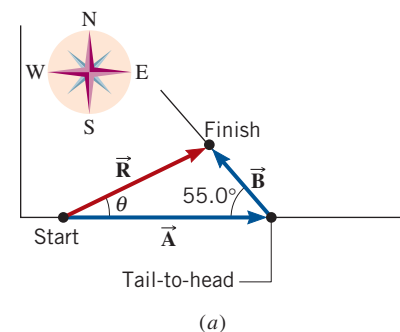
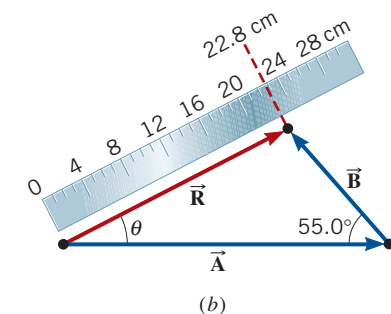

FIGURE 1.11 The addition of two perpendicular displacement vectors \vec{A} and \vec{B} gives the resultant vector \vec{R} .



(a)



(b)

FIGURE 1.12 (a) The two displacement vectors \vec{A} and \vec{B} are neither colinear nor perpendicular, but even so they add to give the resultant vector \vec{R} . (b) In one method for adding them together, a graphical technique is used.

the drawing is constructed. In **Figure 1.12b**, for example, a scale of one centimeter of arrow length for each 10.0 m of displacement is used, and it can be seen that the length of the arrow representing \vec{R} is 22.8 cm. Since each centimeter corresponds to 10.0 m of displacement, the magnitude of \vec{R} is 228 m. The angle θ , which gives the direction of \vec{R} , can be measured with a protractor to be $\theta = 26.7^\circ$ north of east.

Subtraction

The subtraction of one vector from another is carried out in a way that depends on the following fact. *When a vector is multiplied by -1 , the magnitude of the vector remains the same, but the direction of the vector is reversed.* Conceptual Example 7 illustrates the meaning of this statement.

CONCEPTUAL EXAMPLE 7 | Multiplying a Vector by -1

Consider two vectors described as follows:

1. A woman climbs 1.2 m up a ladder, so that her displacement vector \vec{D} is 1.2 m, upward along the ladder, as in **Figure 1.13a**.
2. A man is pushing with 450 N of force on his stalled car, trying to move it eastward. The force vector \vec{F} that he applies to the car is 450 N, due east, as in **Figure 1.14a**.

What are the physical meanings of the vectors $-\vec{D}$ and $-\vec{F}$?

- (a) $-\vec{D}$ points upward along the ladder and has a magnitude of -1.2 m; $-\vec{F}$ points due east and has a magnitude of -450 N.
 (b) $-\vec{D}$ points downward along the ladder and has a magnitude of -1.2 m; $-\vec{F}$ points due west and has a magnitude of -450 N.

- (c) $-\vec{D}$ points downward along the ladder and has a magnitude of 1.2 m; $-\vec{F}$ points due west and has a magnitude of 450 N.

Reasoning A displacement vector of $-\vec{D}$ is $(-1)\vec{D}$. The presence of the (-1) factor reverses the direction of the vector, but does not change its magnitude. Similarly, a force vector of $-\vec{F}$ has the same magnitude as the vector \vec{F} but has the opposite direction.

Answer (a) and (b) are incorrect. While scalars can sometimes be negative, magnitudes of vectors are never negative.

Answer (c) is correct. The vectors $-\vec{D}$ and $-\vec{F}$ have the same magnitudes as \vec{D} and \vec{F} , but point in the opposite direction, as indicated in **Figures 1.13b** and **1.14b**.

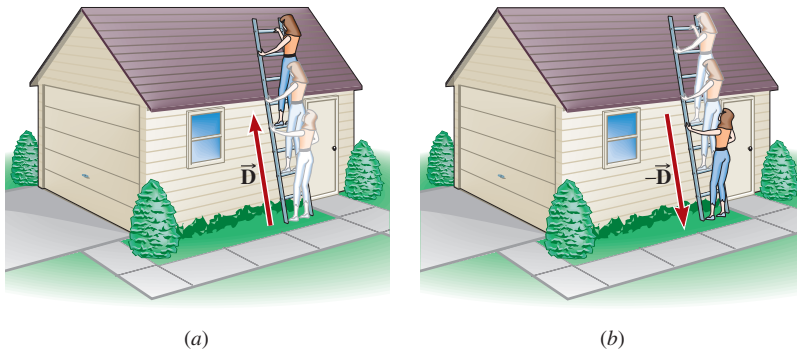

FIGURE 1.13 (a) The displacement vector for a woman climbing 1.2 m up a ladder is \vec{D} . (b) The displacement vector for a woman climbing 1.2 m down a ladder is $-\vec{D}$.

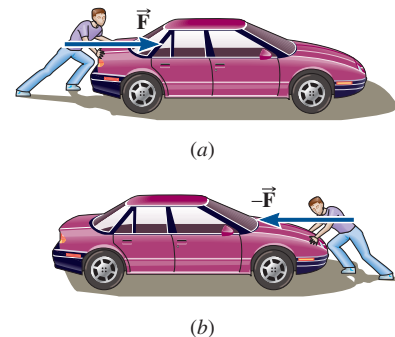

FIGURE 1.14 (a) The force vector for a man pushing on a car with 450 N of force in a direction due east is \vec{F} . (b) The force vector for a man pushing on a car with 450 N of force in a direction due west is $-\vec{F}$.

In practice, vector subtraction is carried out exactly like vector addition, except that one of the vectors added is multiplied by a scalar factor of -1 . To see why, look at the two vectors \vec{A} and \vec{B} in **Figure 1.15a**. These vectors add together to give a third vector \vec{C} , according to $\vec{C} = \vec{A} + \vec{B}$. Therefore, we can calculate vector \vec{A} as $\vec{A} = \vec{C} - \vec{B}$, which is an example of vector subtraction. However, we can also write this result as $\vec{A} = \vec{C} + (-\vec{B})$ and treat it as vector addition. **Figure 1.15b** shows how to calculate vector \vec{A} by adding the vectors \vec{C} and $-\vec{B}$. Notice that vectors \vec{C} and $-\vec{B}$ are arranged tail to head and that any suitable method of vector addition can be employed to determine \vec{A} .

Check Your Understanding

(The answers are given at the end of the book.)

- Two vectors \vec{A} and \vec{B} are added together to give a resultant vector \vec{R} : $\vec{R} = \vec{A} + \vec{B}$. The magnitudes of \vec{A} and \vec{B} are 3 m and 8 m, respectively, but the vectors can have any orientation. What are (a) the maximum possible value and (b) the minimum possible value for the magnitude of \vec{R} ?
- Can two nonzero perpendicular vectors be added together so their sum is zero?
- Can three or more vectors with unequal magnitudes be added together so their sum is zero?
- In preparation for this question, review Conceptual Example 7. Vectors \vec{A} and \vec{B} satisfy the vector equation $\vec{A} + \vec{B} = 0$. (a) How does the magnitude of \vec{B} compare with the magnitude of \vec{A} ? (b) How does the direction of \vec{B} compare with the direction of \vec{A} ?
- Vectors \vec{A} , \vec{B} , and \vec{C} satisfy the vector equation $\vec{A} + \vec{B} = \vec{C}$, and their magnitudes are related by the scalar equation $A^2 + B^2 = C^2$. How is vector \vec{A} oriented with respect to vector \vec{B} ?
- Vectors \vec{A} , \vec{B} , and \vec{C} satisfy the vector equation $\vec{A} + \vec{B} = \vec{C}$, and their magnitudes are related by the scalar equation $A + B = C$. How is vector \vec{A} oriented with respect to vector \vec{B} ?

1.7 The Components of a Vector

Vector Components

Suppose a car moves along a straight line from start to finish, as in **Figure 1.16**, the corresponding displacement vector being \vec{r} . The magnitude and direction of the vector \vec{r} give the distance and direction traveled along the straight line. However, the car could also arrive at the finish point by first moving due east, turning through 90° , and then moving due north. This alternative path is shown in the drawing and is associated with the two displacement vectors \vec{x} and \vec{y} . The vectors \vec{x} and \vec{y} are called the x vector component and the y vector component of \vec{r} .

Vector components are very important in physics and have two basic features that are apparent in **Figure 1.16**. One is that the components add together to equal the original vector:

$$\vec{r} = \vec{x} + \vec{y}$$

The components \vec{x} and \vec{y} , when added vectorially, convey exactly the same meaning as does the original vector \vec{r} : they indicate how the finish point is displaced relative to the starting point. The other feature of vector components that is apparent in **Figure 1.16** is that \vec{x} and \vec{y} are not just any two vectors that add together to give the original vector \vec{r} : they are perpendicular vectors. This perpendicularity is a valuable characteristic, as we will soon see.

Any type of vector may be expressed in terms of its components, in a way similar to that illustrated for the displacement vector in **Figure 1.16**. **Interactive Figure 1.17** shows an arbitrary vector \vec{A} and its vector components \vec{A}_x and \vec{A}_y . The components are drawn parallel to convenient x and y axes and are perpendicular. They add vectorially to equal the original vector \vec{A} :

$$\vec{A} = \vec{A}_x + \vec{A}_y$$

There are times when a drawing such as **Interactive Figure 1.17** is not the most convenient way to represent vector components, and **Figure 1.18** presents an alternative method. The disadvantage of this alternative is that the tail-to-head arrangement of \vec{A}_x and \vec{A}_y is missing, an arrangement that is a nice reminder that \vec{A}_x and \vec{A}_y add together to equal \vec{A} .

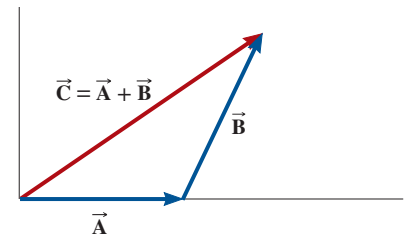

(a)

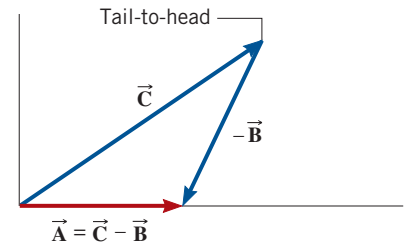

(b)

FIGURE 1.15 (a) Vector addition according to $\vec{C} = \vec{A} + \vec{B}$. (b) Vector subtraction according to $\vec{A} = \vec{C} - \vec{B} = \vec{C} + (-\vec{B})$.

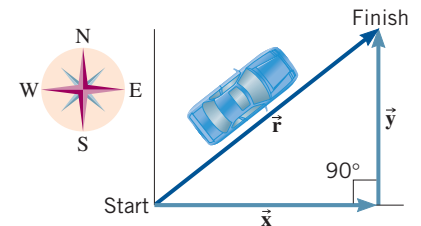
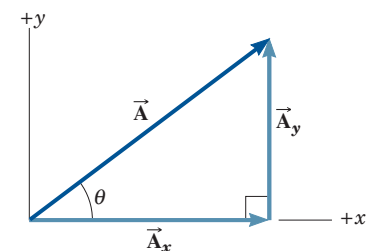

FIGURE 1.16 The displacement vector \vec{r} and its vector components \vec{x} and \vec{y} .



INTERACTIVE FIGURE 1.17 An arbitrary vector \vec{A} and its vector components \vec{A}_x and \vec{A}_y .

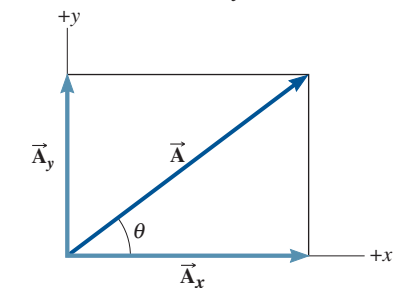

FIGURE 1.18 This alternative way of drawing the vector \vec{A} and its vector components is completely equivalent to that shown in **Interactive Figure 1.17**.

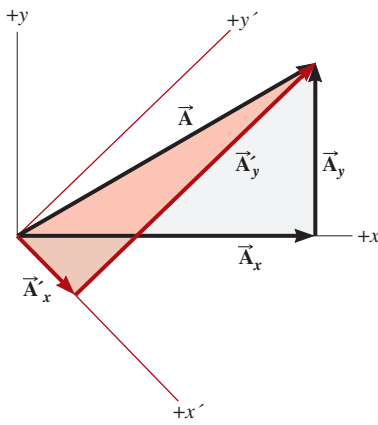

FIGURE 1.19 The vector components of the vector depend on the orientation of the axes used as a reference.

The definition that follows summarizes the meaning of vector components:

DEFINITION OF VECTOR COMPONENTS

In two dimensions, the vector components of a vector \vec{A} are two perpendicular vectors \vec{A}_x and \vec{A}_y that are parallel to the x and y axes, respectively, and add together vectorially according to $\vec{A} = \vec{A}_x + \vec{A}_y$.

Problem-Solving Insight In general, the components of any vector can be used in place of the vector itself in any calculation where it is convenient to do so.

The values calculated for vector components depend on the orientation of the vector relative to the axes used as a reference. **Figure 1.19** illustrates this fact for a vector \vec{A} by showing two sets of axes, one set being rotated clockwise relative to the other. With respect to the black axes, vector \vec{A} has perpendicular vector components \vec{A}_x and \vec{A}_y ; with respect to the colored rotated axes, vector \vec{A} has different vector components \vec{A}'_x and \vec{A}'_y . The choice of which set of components to use is purely a matter of convenience.

Scalar Components

It is often easier to work with the **scalar components**, A_x and A_y (note the italic symbols), rather than the vector components \vec{A}_x and \vec{A}_y . Scalar components are positive or negative numbers (with units) that are defined as follows: The scalar component A_x has a magnitude equal to that of \vec{A}_x and is given a positive sign if \vec{A}_x points along the $+x$ axis and a negative sign if \vec{A}_x points along the $-x$ axis. The scalar component A_y is defined in a similar manner. The following table shows an example of vector and scalar components:

Vector Components	Scalar Components	Unit Vectors
$\vec{A}_x = 8$ meters, directed along the $+x$ axis	$A_x = +8$ meters	$\vec{A}_x = (+8 \text{ meters})\hat{x}$
$\vec{A}_y = 10$ meters, directed along the $-y$ axis	$A_y = -10$ meters	$\vec{A}_y = (-10 \text{ meters})\hat{y}$

In this text, when we use the term “component,” we will be referring to a scalar component, unless otherwise indicated.

Another method of expressing vector components is to use unit vectors. A **unit vector** is a vector that has a magnitude of 1, but no dimensions. We will use a caret (^) to distinguish it from other vectors. Thus,

\hat{x} is a dimensionless unit vector of length 1 that points in the positive x direction, and

\hat{y} is a dimensionless unit vector of length 1 that points in the positive y direction.

These unit vectors are illustrated in **Figure 1.20**. With the aid of unit vectors, the vector components of an arbitrary vector \vec{A} can be written as $\vec{A}_x = A_x\hat{x}$ and $\vec{A}_y = A_y\hat{y}$, where A_x and A_y are its scalar components (see the drawing and the third column of the table above). The vector \vec{A} is then written as $\vec{A} = A_x\hat{x} + A_y\hat{y}$.

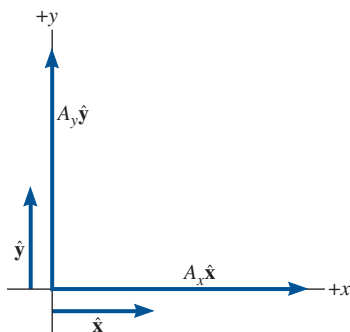

FIGURE 1.20 The dimensionless unit vectors \hat{x} and \hat{y} have magnitudes equal to 1, and they point in the $+x$ and $+y$ directions, respectively. Expressed in terms of unit vectors, the vector components of the vector \vec{A} are $A_x\hat{x}$ and $A_y\hat{y}$.

Resolving a Vector into Its Components

If the magnitude and direction of a vector are known, it is possible to find the components of the vector. The process of finding the components is called “resolving the vector into its components.” As Example 8 illustrates, this process can be carried out with the aid of trigonometry, because the two perpendicular vector components and the original vector form a right triangle.

EXAMPLE 8 | Finding the Components of a Vector

A displacement vector \vec{r} has a magnitude of $r = 175$ m and points at an angle of 50.0° relative to the x axis in **Figure 1.21**. Find the x and y components of this vector.

Reasoning We will base our solution on the fact that the triangle formed in **Figure 1.21** by the vector \vec{r} and its components \vec{x} and \vec{y} is a right triangle. This fact enables us to use the trigonometric sine and cosine functions, as defined in Equations 1.1 and 1.2.

Problem-Solving Insight You can check to see whether the components of a vector are correct by substituting them into the Pythagorean theorem in order to calculate the magnitude of the original vector.

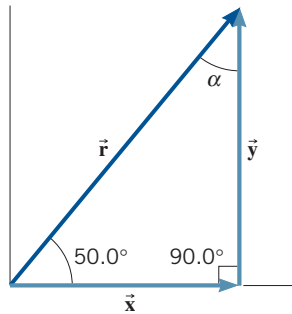

FIGURE 1.21 The x and y components of the displacement vector \vec{r} can be found using trigonometry.

Solution The y component can be obtained using the 50.0° angle and Equation 1.1, $\sin \theta = y/r$:

$$y = r \sin \theta = (175 \text{ m})(\sin 50.0^\circ) = \boxed{134 \text{ m}}$$

In a similar fashion, the x component can be obtained using the 50.0° angle and Equation 1.2, $\cos \theta = x/r$:

$$x = r \cos \theta = (175 \text{ m})(\cos 50.0^\circ) = \boxed{112 \text{ m}}$$

Math Skills Either acute angle of a right triangle can be used to determine the components of a vector. The choice of angle is a matter of convenience. For instance, instead of the 50.0° angle, it is also possible to use the angle α in **Figure 1.21**. Since $\alpha + 50.0^\circ = 90.0^\circ$, it follows that $\alpha = 40.0^\circ$. The solution using α yields the same answers as the solution using the 50.0° angle:

$$\cos \alpha = \frac{y}{r}$$

$$y = r \cos \alpha = (175 \text{ m})(\cos 40.0^\circ) = \boxed{134 \text{ m}}$$

$$\sin \alpha = \frac{x}{r}$$

$$x = r \sin \alpha = (175 \text{ m})(\sin 40.0^\circ) = \boxed{112 \text{ m}}$$

Since the vector components and the original vector form a right triangle, the Pythagorean theorem can be applied to check the validity of calculations such as those in Example 8. Thus, with the components obtained in Example 8, the theorem can be used to verify that the magnitude of the original vector is indeed 175 m, as given initially:

$$r = \sqrt{(112 \text{ m})^2 + (134 \text{ m})^2} = 175 \text{ m}$$

It is possible for one of the components of a vector to be zero. This does not mean that the vector itself is zero, however.

Problem-Solving Insight For a vector to be zero, every vector component must individually be zero.

Thus, in two dimensions, saying that $\vec{A} = \mathbf{0}$ is equivalent to saying that $\vec{A}_x = \mathbf{0}$ and $\vec{A}_y = \mathbf{0}$. Or, stated in terms of scalar components, if $\vec{A} = \mathbf{0}$, then $A_x = 0$ and $A_y = 0$.

Problem-Solving Insight Two vectors are equal if, and only if, they have the same magnitude and direction.

Thus, if one displacement vector points east and another points north, they are *not* equal, even if each has the same magnitude of 480 m. In terms of vector components, two vectors \vec{A} and \vec{B} are equal if, and only if, each vector component of one is equal to the corresponding vector component of the other. In two dimensions, if $\vec{A} = \vec{B}$, then $\vec{A}_x = \vec{B}_x$ and $\vec{A}_y = \vec{B}_y$. Alternatively, using scalar components, we write that $A_x = B_x$ and $A_y = B_y$.

Check Your Understanding

(The answers are given at the end of the book.)

12. Which of the following displacement vectors (if any) are equal?

Variable	Magnitude	Direction
\vec{A}	100 m	30° north of east
\vec{B}	100 m	30° south of west
\vec{C}	50 m	30° south of west
\vec{D}	100 m	60° east of north

13. Two vectors, \vec{A} and \vec{B} , are shown in **CYU Figure 1.1**. (a) What are the signs (+ or -) of the scalar components, A_x and A_y , of the vector \vec{A} ? (b) What are the signs of the scalar components, B_x and B_y , of the vector \vec{B} ? (c) What are the signs of the scalar components, R_x and R_y , of the vector \vec{R} , where $\vec{R} = \vec{A} + \vec{B}$?

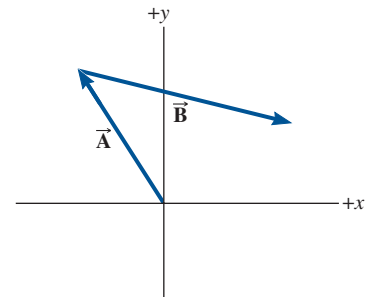

CYU FIGURE 1.1

14. Are two vectors with the same magnitude necessarily equal?

15. The magnitude of a vector has doubled, its direction remaining the same. Can you conclude that the magnitude of each component of the vector has doubled?

16. The tail of a vector is fixed to the origin of an x, y axis system. Originally the vector points along the $+x$ axis and has a magnitude of 12 units. As time passes, the vector rotates counterclockwise. What are the sizes of the x and y components of the vector for the following rotational angles? (a) 90° (b) 180° (c) 270° (d) 360°

17. A vector has a component of zero along the x axis of a certain axis system. Does this vector necessarily have a component of zero along the x axis of another (rotated) axis system?

1.8 Addition of Vectors by Means of Components

The components of a vector provide the most convenient and accurate way of adding (or subtracting) any number of vectors. For example, suppose that vector \vec{A} is added to vector \vec{B} . The resultant vector is \vec{C} , where $\vec{C} = \vec{A} + \vec{B}$. **Interactive Figure 1.22a** illustrates this vector addition, along with the x and y vector components of \vec{A} and \vec{B} . In part *b* of the drawing, the vectors \vec{A} and \vec{B} have been removed, because we can use the vector components of these vectors in place of them. The vector component \vec{B}_x has been shifted downward and arranged tail to head with vector component \vec{A}_x . Similarly, the vector component \vec{A}_y has been shifted to the right and arranged tail to head with the vector component \vec{B}_y . The x components are colinear and add together to give the x component of the resultant vector \vec{C} . In like fashion, the y components are colinear and add together to give the y component of \vec{C} . In terms of scalar components, we can write

$$C_x = A_x + B_x \quad \text{and} \quad C_y = A_y + B_y$$

The vector components \vec{C}_x and \vec{C}_y of the resultant vector form the sides of the right triangle shown in **Interactive Figure 1.22c**. Thus, we can find the magnitude of \vec{C} by using the Pythagorean theorem:

$$C = \sqrt{C_x^2 + C_y^2}$$

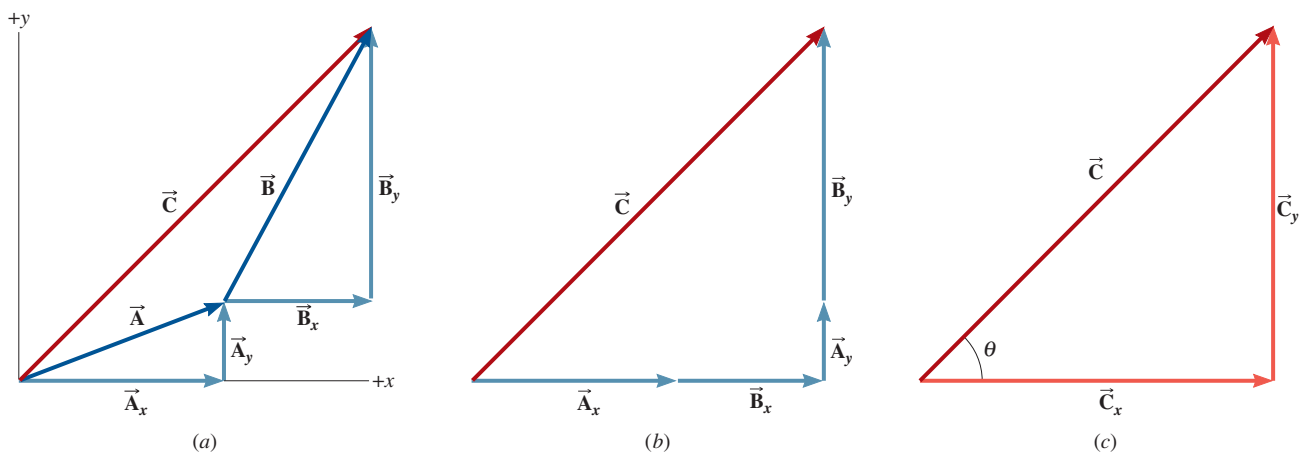

INTERACTIVE FIGURE 1.22 (a) The vectors \vec{A} and \vec{B} add together to give the resultant vector \vec{C} .

The x and y components of \vec{A} and \vec{B} are also shown. (b) The drawing illustrates that $\vec{C}_x = \vec{A}_x + \vec{B}_x$ and $\vec{C}_y = \vec{A}_y + \vec{B}_y$. (c) Vector \vec{C} and its components form a right triangle.

The angle θ that \vec{C} makes with the x axis is given by $\theta = \tan^{-1}(C_y/C_x)$. Example 9 illustrates how to add several vectors using the component method.

Analyzing Multiple-Concept Problems

EXAMPLE 9 | The Component Method of Vector Addition

A jogger runs 145 m in a direction 20.0° east of north (displacement vector \vec{A}) and then 105 m in a direction 35.0° south of east (displacement vector \vec{B}). Using components, determine the magnitude and direction of the resultant vector \vec{C} for these two displacements.

Reasoning Figure 1.23 shows the vectors \vec{A} and \vec{B} , assuming that the y axis corresponds to the direction due north. The vectors are arranged in a tail-to-head fashion, with the resultant vector \vec{C} drawn from the tail of \vec{A} to the head of \vec{B} . The components of the vectors are also shown in the figure. Since \vec{C} and its components form a right triangle (red in the drawing), we will use the Pythagorean theorem and trigonometry to express the magnitude and directional angle θ for \vec{C} in terms of its components. The components of \vec{C} will then be obtained from the components of \vec{A} and \vec{B} and the data given for these two vectors.

Knowns and Unknowns The data for this problem are listed in the table that follows:

Description	Symbol	Value	Comment
Magnitude of vector \vec{A}		145 m	
Direction of vector \vec{A}		20.0° east of north	See Figure 1.23.
Magnitude of vector \vec{B}		105 m	
Direction of vector \vec{B}		35.0° south of east	See Figure 1.23.
Unknown Variable			
Magnitude of resultant vector	C	?	
Direction of resultant vector	θ	?	

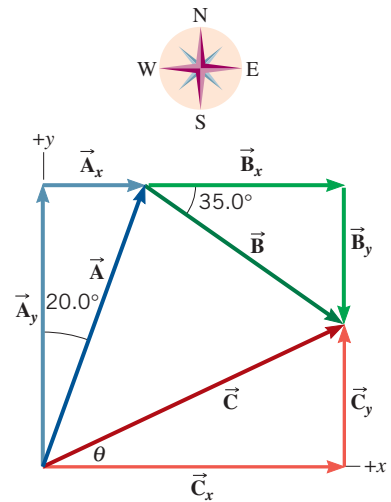

FIGURE 1.23 The vectors \vec{A} and \vec{B} add together to give the resultant vector \vec{C} . The vector components of \vec{A} and \vec{B} are also shown. The resultant vector \vec{C} can be obtained once its components have been found.

Modeling the Problem

STEP 1 Magnitude and Direction of \vec{C} In Figure 1.23 the vector \vec{C} and its components \vec{C}_x and \vec{C}_y form a right triangle, as the red arrows show. Applying the Pythagorean theorem to this right triangle shows that the magnitude of \vec{C} is given by Equation 1a at the right. From the red triangle it also follows that the directional angle θ for the vector \vec{C} is given by Equation 1b at the right.

$$C = \sqrt{C_x^2 + C_y^2} \quad (1a)$$

$$\theta = \tan^{-1}\left(\frac{C_y}{C_x}\right) \quad (1b)$$

STEP 2 Components of \vec{C} Since vector \vec{C} is the resultant of vectors \vec{A} and \vec{B} , we have $\vec{C} = \vec{A} + \vec{B}$ and can write the scalar components of \vec{C} as the sum of the scalar components of \vec{A} and \vec{B} :

$$C_x = A_x + B_x \quad \text{and} \quad C_y = A_y + B_y$$

These expressions can be substituted into Equations 1a and 1b for the magnitude and direction of \vec{C} , as shown at the right.

$$C = \sqrt{C_x^2 + C_y^2} \quad (1a)$$

$$\begin{cases} C_x = A_x + B_x \\ C_y = A_y + B_y \end{cases} \quad (2)$$

$$\theta = \tan^{-1}\left(\frac{C_y}{C_x}\right) \quad (1b)$$

$$\begin{cases} C_x = A_x + B_x \\ C_y = A_y + B_y \end{cases} \quad (2)$$

Solution Algebraically combining the results of each step, we find that

$$\begin{aligned} C &\stackrel{\text{STEP 1}}{=} \sqrt{C_x^2 + C_y^2} \stackrel{\text{STEP 2}}{=} \sqrt{(A_x + B_x)^2 + (A_y + B_y)^2} \\ \theta &\stackrel{\text{STEP 1}}{=} \tan^{-1}\left(\frac{C_y}{C_x}\right) \stackrel{\text{STEP 2}}{=} \tan^{-1}\left(\frac{A_y + B_y}{A_x + B_x}\right) \end{aligned}$$

To use these results we need values for the individual components of \vec{A} and \vec{B} . Referring to **Figure 1.23**, we find these values to be

$$A_x = (145 \text{ m}) \sin 20.0^\circ = 49.6 \text{ m} \quad \text{and}$$

$$A_y = (145 \text{ m}) \cos 20.0^\circ = 136 \text{ m}$$

$$B_x = (105 \text{ m}) \cos 35.0^\circ = 86.0 \text{ m} \quad \text{and}$$

$$B_y = -(105 \text{ m}) \sin 35.0^\circ = -60.2 \text{ m}$$

Note that the component B_y is negative, because \vec{B}_y points downward, in the negative y direction in the drawing. Substituting these values into the results for C and θ gives

$$C = \sqrt{(A_x + B_x)^2 + (A_y + B_y)^2}$$

$$= \sqrt{(49.6 \text{ m} + 86.0 \text{ m})^2 + (136 \text{ m} - 60.2 \text{ m})^2} = \boxed{155 \text{ m}}$$

$$\theta = \tan^{-1} \left(\frac{A_y + B_y}{A_x + B_x} \right)$$

$$= \tan^{-1} \left(\frac{136 \text{ m} - 60.2 \text{ m}}{49.6 \text{ m} + 86.0 \text{ m}} \right) = \boxed{29^\circ}$$

Math Skills According to the definitions given in Equations 1.1 and 1.2, the sine and cosine functions are $\sin \phi = \frac{h_o}{h}$ and $\cos \phi = \frac{h_a}{h}$, where h_o is the length of the side of a right triangle that is opposite the angle ϕ , h_a is the length of the side adjacent to the angle ϕ , and h is the length of the hypotenuse (see **Figure 1.24a**). Applications of the sine and cosine functions to determine the scalar components of a vector occur frequently. In such applications we begin by identifying the angle ϕ . **Figure 1.24b** shows the relevant portion of **Figure 1.23** and indicates that $\phi = 20.0^\circ$ for the vector \vec{A} . In this case we have $h_o = A_x$, $h_a = A_y$, and $h = A = 145 \text{ m}$; it follows that

$$\sin 20.0^\circ = \frac{h_o}{h} = \frac{A_x}{A} \quad \text{or} \quad A_x = A \sin 20.0^\circ = (145 \text{ m}) \sin 20.0^\circ = 49.6 \text{ m}$$

$$\cos 20.0^\circ = \frac{h_a}{h} = \frac{A_y}{A} \quad \text{or} \quad A_y = A \cos 20.0^\circ = (145 \text{ m}) \cos 20.0^\circ = 136 \text{ m}$$

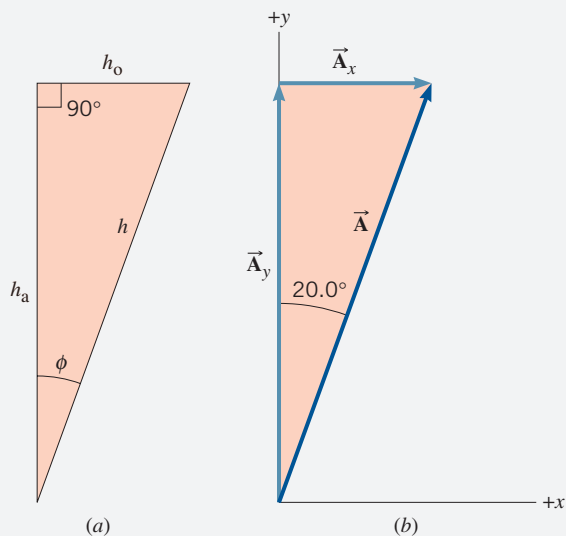
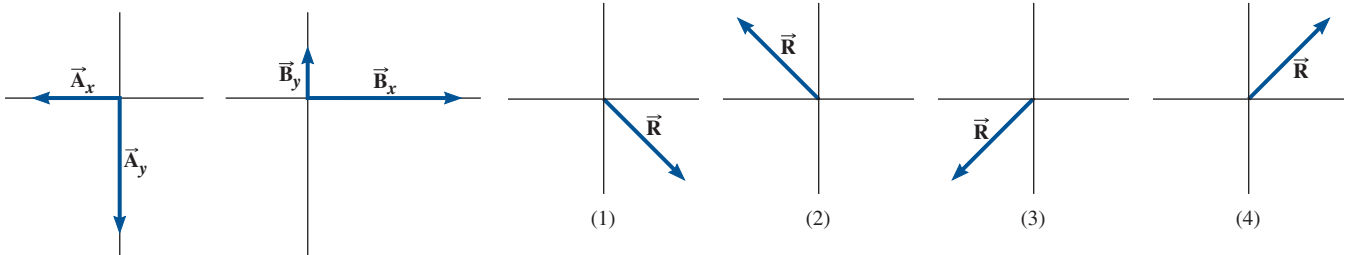

FIGURE 1.24 Math Skills drawing.

Check Your Understanding

(The answer is given at the end of the book.)

18. Two vectors, \vec{A} and \vec{B} , have vector components that are shown (to the same scale) in **CYU Figure 1.2**. The resultant vector is labeled \vec{R} . Which drawing shows the correct vector sum of $\vec{A} + \vec{B}$? (a) 1, (b) 2, (c) 3, (d) 4



CYU FIGURE 1.2

In later chapters we will often use the component method for vector addition. For future reference, the main features of the reasoning strategy used in this technique are summarized below.

REASONING STRATEGY The Component Method of Vector Addition

1. For each vector to be added, determine the x and y components relative to a conveniently chosen x, y coordinate system. Be sure to take into account the directions of the components by using plus and minus signs to denote whether the components point along the positive or negative axes.
2. Find the algebraic sum of the x components, which is the x component of the resultant vector. Similarly, find the algebraic sum of the y components, which is the y component of the resultant vector.
3. Use the x and y components of the resultant vector and the Pythagorean theorem to determine the magnitude of the resultant vector.
4. Use the inverse sine, inverse cosine, or inverse tangent function to find the angle that specifies the direction of the resultant vector.

EXAMPLE 10 | BIO Multi-joint Movements

Figure 1.25 shows an example of a multi-joint movement involving the shoulder and elbow joints. The view from above shows a person holding a ball in a position that involves both shoulder flexion and elbow extension. Vector \vec{A} represents the position of the elbow joint relative to the shoulder joint, and vector \vec{B} represents the position of the ball relative to the elbow joint. Use the component method of vector addition and the angles given in the figure to find the magnitude and direction (θ) of vector \vec{C} , which represents the position of the ball relative to the shoulder joint. The magnitude of vector \vec{A} is 35.6 cm, and the magnitude of vector \vec{B} is 31.2 cm. The angle θ is measured relative to a vertical anatomical plane known as the frontal or coronal plane.

Reasoning Similar to Example 9, the vectors \vec{A} and \vec{B} in **Figure 1.25** are drawn tail-to-head. Thus, the resultant vector $\vec{C} = \vec{A} + \vec{B}$. The components of vector \vec{C} will be obtained from the components of vectors \vec{A} and \vec{B} . Once C_x and C_y are known, we can calculate the magnitude of vector \vec{C} using the Pythagorean theorem. The directional angle θ will be determined from the components of vector \vec{C} .

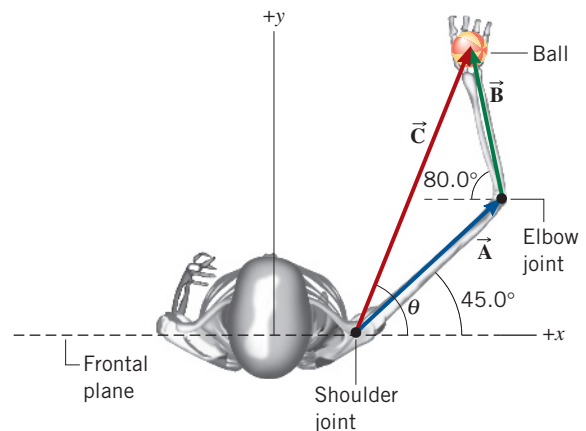

FIGURE 1.25 Top view of a multi-joint movement involving the shoulder and elbow joints. The vectors \vec{A} and \vec{B} add together to give the resultant vector \vec{C} , which represents the position vector of the ball with respect to the shoulder joint. The resultant vector \vec{C} can be obtained, once its components are determined.

Solution Applying the component method of vector addition, we know that $C_x = A_x + B_x$, and $C_y = A_y + B_y$. From **Figure 1.25**, we see that $A_x = (35.6 \text{ cm}) \cos 45^\circ = 25.2 \text{ cm}$, $B_x = -(31.2) \cos 80^\circ = -5.42 \text{ cm}$, $A_y = (35.6 \text{ cm}) \sin 45^\circ = 25.2 \text{ cm}$, and $B_y = (31.2 \text{ cm}) \sin 80^\circ = 30.7 \text{ cm}$. Therefore, $C_x = 25.2 \text{ cm} + (-5.42 \text{ cm}) = 19.8 \text{ cm}$, and $C_y = 25.2 \text{ cm} + 30.7 \text{ cm} = 55.9 \text{ cm}$. The magnitude of vector \vec{C} is now found by the Pythagorean theorem:

$C = \sqrt{C_x^2 + C_y^2} = \sqrt{(19.8 \text{ cm})^2 + (55.9 \text{ cm})^2} = \boxed{59.3 \text{ cm}}$ The directional angle θ is found by using the tangent function:

$$\theta = \tan^{-1}\left(\frac{C_y}{C_x}\right) = \tan^{-1}\left(\frac{55.9 \text{ cm}}{19.8 \text{ cm}}\right) = \boxed{70.5^\circ}$$

Concept Summary

1.2 Units The SI system of units includes the meter (m), the kilogram (kg), and the second (s) as the base units for length, mass, and time, respectively. One meter is the distance that light travels in a vacuum in a time of $1/299\,792\,458$ second. One kilogram is the mass of a standard cylinder of platinum–iridium alloy kept at the International Bureau of Weights and Measures. One second is the time for a certain type of electromagnetic wave emitted by cesium-133 atoms to undergo $9\,192\,631\,770$ wave cycles.

1.3 The Role of Units in Problem Solving To convert a number from one unit to another, multiply the number by the ratio of the two units. For instance, to convert 979 meters to feet, multiply 979 meters by the factor (3.281 foot/1 meter).

The dimension of a quantity represents its physical nature and the type of unit used to specify it. Three such dimensions are length [L], mass [M], time [T]. Dimensional analysis is a method for checking mathematical relations for the consistency of their dimensions.

1.4 Trigonometry The sine, cosine, and tangent functions of an angle θ are defined in terms of a right triangle that contains θ , as in Equations 1.1–1.3, where h_o and h_a are, respectively, the lengths of the sides opposite and adjacent to the angle θ , and h is the length of the hypotenuse.

$$\sin \theta = \frac{h_o}{h} \quad (1.1)$$

$$\cos \theta = \frac{h_a}{h} \quad (1.2)$$

$$\tan \theta = \frac{h_o}{h_a} \quad (1.3)$$

The inverse sine, inverse cosine, and inverse tangent functions are given in Equations 1.4–1.6.

$$\theta = \sin^{-1}\left(\frac{h_o}{h}\right) \quad (1.4)$$

$$\theta = \cos^{-1}\left(\frac{h_a}{h}\right) \quad (1.5)$$

$$\theta = \tan^{-1}\left(\frac{h_o}{h_a}\right) \quad (1.6)$$

The Pythagorean theorem states that the square of the length of the hypotenuse of a right triangle is equal to the sum of the squares of the lengths of the other two sides, according to Equation 1.7.

$$h^2 = h_o^2 + h_a^2 \quad (1.7)$$

1.5 Scalars and Vectors A scalar quantity is described by its size, which is also called its magnitude. A vector quantity has both a magnitude and a direction. Vectors are often represented by arrows, the length of the arrow being proportional to the magnitude of the vector and the direction of the arrow indicating the direction of the vector.

1.6 Vector Addition and Subtraction One procedure for adding vectors utilizes a graphical technique, in which the vectors to be added are arranged in a tail-to-head fashion. The resultant vector is drawn from the tail of the first vector to the head of the last vector. The subtraction of a vector is treated as the addition of a vector that has been multiplied by a scalar factor of -1 . Multiplying a vector by -1 reverses the direction of the vector.

1.7 The Components of a Vector In two dimensions, the vector components of a vector \vec{A} are two perpendicular vectors \vec{A}_x and \vec{A}_y that are parallel to the x and y axes, respectively, and that add together vectorially so that $\vec{A} = \vec{A}_x + \vec{A}_y$. The scalar component A_x has a magnitude that is equal to that of \vec{A}_x and is given a positive sign if \vec{A}_x points along the $+x$ axis and a negative sign if \vec{A}_x points along the $-x$ axis. The scalar component A_y is defined in a similar manner.

Two vectors are equal if, and only if, they have the same magnitude and direction. Alternatively, two vectors are equal in two dimensions if the x vector components of each are equal and the y vector components of each are equal. A vector is zero if, and only if, each of its vector components is zero.

1.8 Addition of Vectors by Means of Components If two vectors \vec{A} and \vec{B} are added to give a resultant \vec{C} such that $\vec{C} = \vec{A} + \vec{B}$, then $C_x = A_x + B_x$ and $C_y = A_y + B_y$, where C_x , A_x , and B_x are the scalar components of the vectors along the x direction, and C_y , A_y , and B_y are the scalar components of the vectors along the y direction.

Focus on Concepts

Additional questions are available for assignment in WileyPLUS.

Section 1.6 Vector Addition and Subtraction

1. During a relay race, runner A runs a certain distance due north and then hands off the baton to runner B, who runs for the same distance in a direction south of east. The two displacement vectors \vec{A} and \vec{B} can be added together to give a resultant vector \vec{R} . Which drawing correctly shows the resultant vector? (a) 1 (b) 2 (c) 3 (d) 4

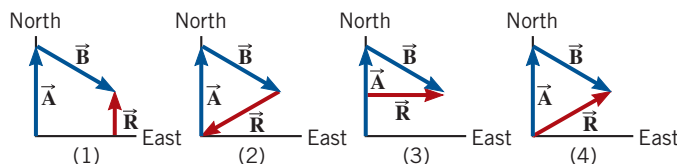

QUESTION 1

2. How is the magnitude R of the resultant vector \vec{R} in the drawing related to the magnitudes A and B of the vectors \vec{A} and \vec{B} ?

Online

- (a) The magnitude of the resultant vector \vec{R} is equal to the sum of the magnitudes of \vec{A} and \vec{B} , or $R = A + B$.
 (b) The magnitude of the resultant vector \vec{R} is greater than the sum of the magnitudes of \vec{A} and \vec{B} , or $R > A + B$.
 (c) The magnitude of the resultant vector \vec{R} is less than the sum of the magnitudes of \vec{A} and \vec{B} , or $R < A + B$.

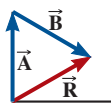

QUESTION 2

3. The first drawing shows three displacement vectors, \vec{A} , \vec{B} , and \vec{C} , which are added in a tail-to-head fashion. The resultant vector is labeled \vec{R} . Which of the following drawings shows the correct resultant vector for $\vec{A} + \vec{B} - \vec{C}$? (a) 1 (b) 2 (c) 3

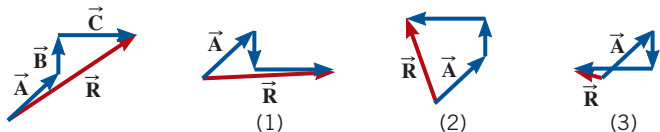

QUESTION 3

4. The first drawing shows the sum of three displacement vectors, \vec{A} , \vec{B} , and \vec{C} . The resultant vector is labeled \vec{R} . Which of the following drawings shows the correct resultant vector for $\vec{A} - \vec{B} - \vec{C}$? (a) 1 (b) 2 (c) 3



QUESTION 4

Section 1.7 The Components of a Vector

5. A person is jogging along a straight line, and her displacement is denoted by the vector \vec{A} in the drawings. Which drawing represents the correct vector components, \vec{A}_x and \vec{A}_y , for the vector \vec{A} ? (a) 1 (b) 2 (c) 3 (d) 4

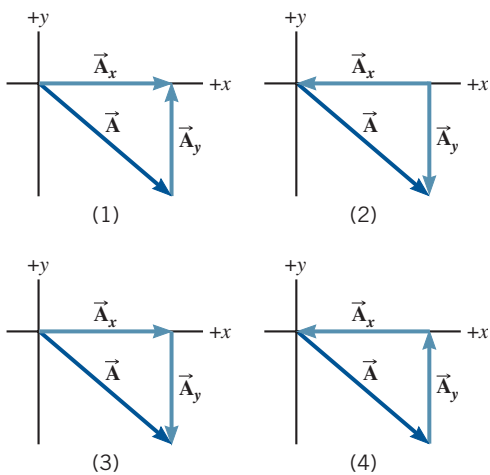

QUESTION 5

6. A person drives a car for a distance of 450.0 m. The displacement \vec{A} of the car is illustrated in the drawing. What are the scalar components of this displacement vector?
 (a) $A_x = 0$ m and $A_y = +450.0$ m
 (b) $A_x = 0$ m and $A_y = -450.0$ m
 (c) $A_x = +450.0$ m and $A_y = +450.0$ m
 (d) $A_x = -450.0$ m and $A_y = 0$ m
 (e) $A_x = -450.0$ m and $A_y = +450.0$ m

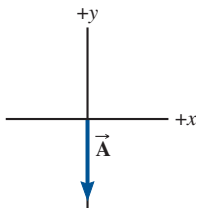

QUESTION 6

7. Drawing a shows a displacement vector \vec{A} (450.0 m along the $-y$ axis). In this x, y coordinate system the scalar components are $A_x = 0$ m and $A_y = -450.0$ m. Suppose that the coordinate system is rotated counterclockwise by 35.0° , but the magnitude (450.0 m) and direction of vector \vec{A} remain unchanged, as in drawing

- b. What are the scalar components, $A_{x'}$ and $A_{y'}$, of the vector \vec{A} in the rotated x', y' coordinate system?

- (a) $A_{x'} = -369$ m and $A_{y'} = -258$ m
 (b) $A_{x'} = +369$ m and $A_{y'} = -258$ m
 (c) $A_{x'} = +258$ m and $A_{y'} = +369$ m
 (d) $A_{x'} = +258$ m and $A_{y'} = -369$ m
 (e) $A_{x'} = -258$ m and $A_{y'} = -369$ m

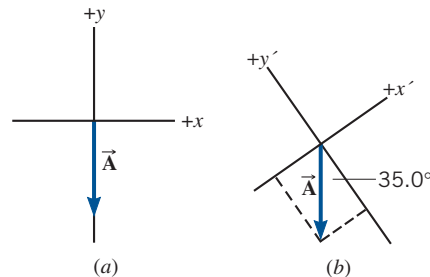

QUESTION 7

8. Suppose the vectors \vec{A} and \vec{B} in the drawing have magnitudes of 6.0 m and are directed as shown. What are A_x and B_x , the scalar components of \vec{A} and \vec{B} along the x axis?

A_x	B_x
(a) $+(6.0 \text{ m}) \cos 35^\circ = +4.9 \text{ m}$	$-(6.0 \text{ m}) \cos 35^\circ = -4.9 \text{ m}$
(b) $+(6.0 \text{ m}) \sin 35^\circ = +3.4 \text{ m}$	$-(6.0 \text{ m}) \cos 35^\circ = -4.9 \text{ m}$
(c) $-(6.0 \text{ m}) \cos 35^\circ = -4.9 \text{ m}$	$+(6.0 \text{ m}) \sin 35^\circ = +3.4 \text{ m}$
(d) $-(6.0 \text{ m}) \cos 35^\circ = -4.9 \text{ m}$	$+(6.0 \text{ m}) \cos 35^\circ = +4.9 \text{ m}$
(e) $-(6.0 \text{ m}) \sin 35^\circ = -3.4 \text{ m}$	$+(6.0 \text{ m}) \sin 35^\circ = +3.4 \text{ m}$

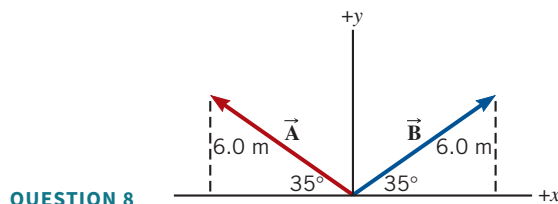

QUESTION 8

Section 1.8 Addition of Vectors by Means of Components

9. Drawing a shows two vectors \vec{A} and \vec{B} , and drawing b shows their components. The scalar components of these vectors are as follows:

$$A_x = -4.9 \text{ m} \quad A_y = +3.4 \text{ m}$$

$$B_x = +4.9 \text{ m} \quad B_y = +3.4 \text{ m}$$

- When the vectors \vec{A} and \vec{B} are added, the resultant vector is \vec{R} , so that $\vec{R} = \vec{A} + \vec{B}$. What are the values of R_x and R_y , the x and y components of \vec{R} ?

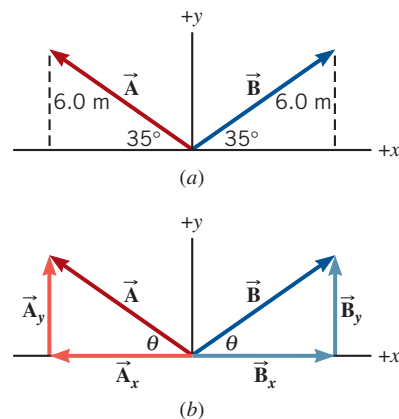

QUESTION 9

10. The displacement vectors \vec{A} and \vec{B} , when added together, give the resultant vector \vec{R} , so that $\vec{R} = \vec{A} + \vec{B}$. Use the data in the drawing to find the magnitude R of the resultant vector and the angle θ that it makes with the $+x$ axis.

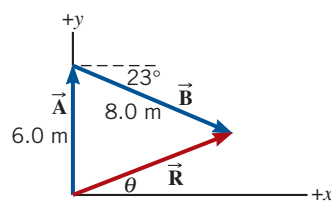

QUESTION 10

Problems

Online

Additional questions are available for assignment in WileyPLUS.

- | | |
|-------------------------------------|-----------------------------------|
| SSM Student Solutions Manual | BIO Biomedical application |
| MMH Problem-solving help | E Easy |
| GO Guided Online Tutorial | M Medium |
| V-HINT Video Hints | H Hard |
| CHALK Chalkboard Videos | WS Worksheet |
| | T Team Problem |

Section 1.2 Units

Section 1.3 The Role of Units in Problem Solving

- E GO** A student sees a newspaper ad for an apartment that has 1330 square feet (ft^2) of floor space. How many square meters of area are there?
- E** Bicyclists in the Tour de France reach speeds of 34.0 miles per hour (mi/h) on flat sections of the road. What is this speed in (a) kilometers per hour (km/h) and (b) meters per second (m/s)?
- E SSM** Vesna Vulovic survived the longest fall on record without a parachute when her plane exploded and she fell 6 miles, 551 yards. What is this distance in meters?
- E** Suppose a man's scalp hair grows at a rate of 0.35 mm per day. What is this growth rate in feet per century?
- E** Given the quantities $a = 9.7 \text{ m}$, $b = 4.2 \text{ s}$, $c = 69 \text{ m/s}$, what is the value of the quantity $d = a^3/(cb^2)$?
- E** Consider the equation $v = \frac{1}{3}zx^t$. The dimensions of the variables v , x , and t are $[L]/[T]$, $[L]$, and $[T]$, respectively. The numerical factor 3 is dimensionless. What must be the dimensions of the variable z , such that both sides of the equation have the same dimensions? Show how you determined your answer.
- E SSM** A bottle of wine known as a magnum contains a volume of 1.5 liters. A bottle known as a jeroboam contains 0.792 U.S. gallons. How many magnums are there in one jeroboam?
- E** The CGS unit for measuring the viscosity of a liquid is the poise (P): $1 \text{ P} = 1 \text{ g}/(\text{s} \cdot \text{cm})$. The SI unit for viscosity is the $\text{kg}/(\text{s} \cdot \text{m})$. The viscosity of water at 0°C is $1.78 \times 10^{-3} \text{ kg}/(\text{s} \cdot \text{m})$. Express this viscosity in poise.
- E** The amount of water on the Earth's surface is 326 million trillion gallons, or 3.26×10^{20} gallons. If all of this water was placed in a sphere, what would be the radius of this sphere in m? Compare this to the radius of the Moon ($1.74 \times 10^6 \text{ m}$).
- M GO CHALK** A partly full paint can has 0.67 U.S. gallons of paint left in it. (a) What is the volume of the paint in cubic meters? (b) If all the remaining paint is used to coat a wall evenly (wall area = 13 m^2), how thick is the layer of wet paint? Give your answer in meters.

- M SSM CHALK** A spring is hanging down from the ceiling, and an object of mass m is attached to the free end. The object is pulled down, thereby stretching the spring, and then released. The object oscillates up and down, and the time T required for one complete up-and-down oscillation is given by the equation $T = 2\pi\sqrt{m/k}$, where k is known as the spring constant. What must be the dimension of k for this equation to be dimensionally correct?

Section 1.4 Trigonometry

- E** You are driving into St. Louis, Missouri, and in the distance you see the famous Gateway to the West arch. This monument rises to a height of 192 m. You estimate your line of sight with the top of the arch to be 2.0° above the horizontal. Approximately how far (in kilometers) are you from the base of the arch?
- E SSM** A highway is to be built between two towns, one of which lies 35.0 km south and 72.0 km west of the other. What is the shortest length of highway that can be built between the two towns, and at what angle would this highway be directed with respect to due west?
- E GO** A hill that has a 12.0% grade is one that rises 12.0 m vertically for every 100.0 m of distance in the horizontal direction. At what angle is such a hill inclined above the horizontal?
- E GO** The corners of a square lie on a circle of diameter $D = 0.35 \text{ m}$. Each side of the square has a length L . Find L .
- E GO** The drawing shows a person looking at a building on top of which an antenna is mounted. The horizontal distance between the person's eyes and the building is 85.0 m. In part a the person is looking at the base of the antenna, and his line of sight makes an angle of 35.0° with the horizontal. In part b the person is looking at the top of the antenna, and his line of sight makes an angle of 38.0° with the horizontal. How tall is the antenna?

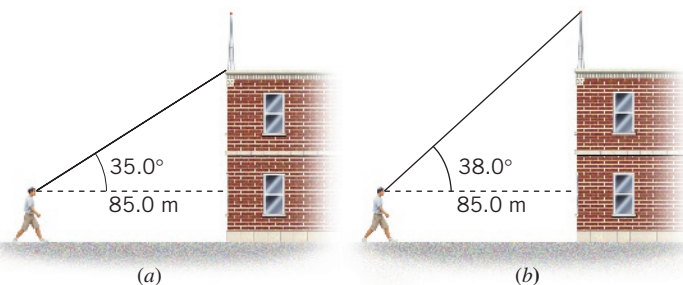

PROBLEM 16

- E CHALK** The two hot-air balloons in the drawing are 48.2 and 61.0 m above the ground. A person in the left balloon observes that the right balloon is 13.3° above the horizontal. What is the horizontal distance x between the two balloons?

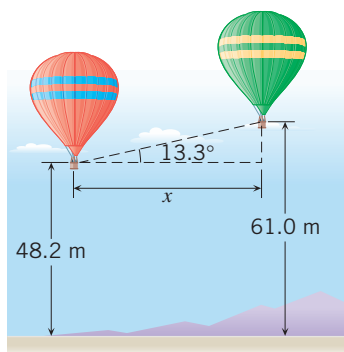

PROBLEM 17

18. **M MMH** The drawing shows sodium and chloride ions positioned at the corners of a cube that is part of the crystal structure of sodium chloride (common table salt). The edges of the cube are each 0.281 nm (1 nm = 1 nanometer = 10^{-9} m) in length. What is the value of the angle θ in the drawing?

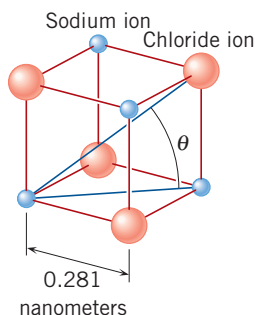

PROBLEM 18

19. **M GO** A person is standing at the edge of the water and looking out at the ocean (see the drawing). The height of the person's eyes above the water is $h = 1.6$ m, and the radius of the earth is $R = 6.38 \times 10^6$ m. (a) How far is it to the horizon? In other words, what is the distance d from the person's eyes to the horizon? (Note: At the horizon the angle between the line of sight and the radius of the earth is 90° .) (b) Express this distance in miles.

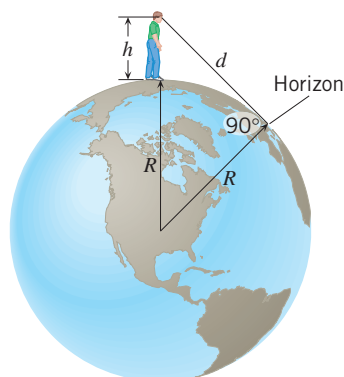

PROBLEM 19

20. **M SSM** Three deer, A, B, and C, are grazing in a field. Deer B is located 62 m from deer A at an angle of 51° north of west. Deer C is located 77° north of east relative to deer A. The distance between deer B and C is 95 m. What is the distance between deer A and C? (Hint: Consider the law of cosines given in Appendix E.)

21. **H** An aerialist on a high platform holds on to a trapeze attached to a support by an 8.0-m cord. (See the drawing.) Just before he jumps off the platform, the cord makes an angle of 41° with the vertical. He jumps, swings down, then back up, releasing the trapeze at the instant it is 0.75 m below its initial height. Calculate the angle θ that the trapeze cord makes with the vertical at this instant.

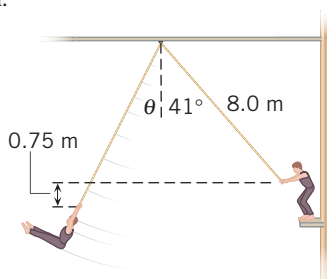

PROBLEM 21

Section 1.6 Vector Addition and Subtraction

22. **E SSM** (a) Two workers are trying to move a heavy crate. One pushes on the crate with a force \vec{A} , which has a magnitude of 445 newtons and is directed due west. The other pushes with a force \vec{B} , which has a magnitude of 325 newtons and is directed due north. What are the magnitude and direction of the resultant force $\vec{A} + \vec{B}$ applied to the crate? (b) Suppose that the second worker applies a force $-\vec{B}$ instead of \vec{B} . What then are the magnitude and direction of the resultant force $\vec{A} - \vec{B}$ applied to the crate? In both cases express the direction relative to due west.

23. **E** A force vector \vec{F}_1 points due east and has a magnitude of 200 newtons. A second force \vec{F}_2 is added to \vec{F}_1 . The resultant of the two vectors has a magnitude of 400 newtons and points along the east/west line. Find the magnitude and direction of \vec{F}_2 . Note that there are two answers.

24. **E SSM** Consider the following four force vectors:

$$\vec{F}_1 = 50.0 \text{ newtons, due east}$$

$$\vec{F}_2 = 10.0 \text{ newtons, due east}$$

$$\vec{F}_3 = 40.0 \text{ newtons, due west}$$

$$\vec{F}_4 = 30.0 \text{ newtons, due west}$$

Which two vectors add together to give a resultant with the smallest magnitude, and which two vectors add to give a resultant with the largest magnitude? In each case specify the magnitude and direction of the resultant.

25. **E GO** Vector \vec{A} has a magnitude of 63 units and points due west, while vector \vec{B} has the same magnitude and points due south. Find the magnitude and direction of (a) $\vec{A} + \vec{B}$ and (b) $\vec{A} - \vec{B}$. Specify the directions relative to due west.

26. **E** Two bicyclists, starting at the same place, are riding toward the same campground by two different routes. One cyclist rides 1080 m due east and then turns due north and travels another 1430 m before reaching the campground. The second cyclist starts out by heading due north for 1950 m and then turns and heads directly toward the campground. (a) At the turning point, how far is the second cyclist from the campground? (b) In what direction (measured relative to due east) must the second cyclist head during the last part of the trip?

27. **E GO** The drawing shows a triple jump on a checkerboard, starting at the center of square A and ending on the center of square B. Each side of a square measures 4.0 cm. What is the magnitude of the displacement of the colored checker during the triple jump?

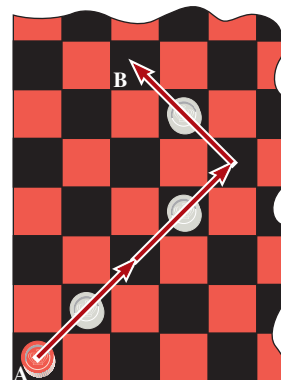

PROBLEM 27

28. **E** Given the vectors \vec{P} and \vec{Q} shown on the grid, sketch and calculate the magnitudes of the vectors (a) $\vec{M} = \vec{P} + \vec{Q}$ and (b) $\vec{K} = 2\vec{P} - \vec{Q}$. Use the tail-to-head method and express the magnitudes in centimeters with the aid of the grid scale shown in the drawing.

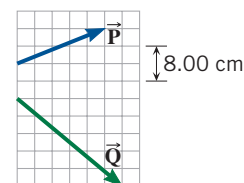

PROBLEM 28

29. **M MMH CHALK** Vector \vec{A} has a magnitude of 12.3 units and points due west. Vector \vec{B} points due north. (a) What is the magnitude of \vec{B} if $\vec{A} + \vec{B}$ has a magnitude of 15.0 units? (b) What is the direction of $\vec{A} + \vec{B}$ relative to due west? (c) What is the magnitude of \vec{B} if $\vec{A} - \vec{B}$ has a magnitude of 15.0 units? (d) What is the direction of $\vec{A} - \vec{B}$ relative to due west?

30. **M SSM** A car is being pulled out of the mud by two forces that are applied by the two ropes shown in the drawing. The dashed line in the drawing bisects the 30.0° angle. The magnitude of the force applied by each rope is 2900 newtons. Arrange the force vectors tail to head and use the graphical technique to answer the following questions. (a) How much force would a single rope need to apply to accomplish the same effect as the two forces added together? (b) How would the single rope be directed relative to the dashed line?

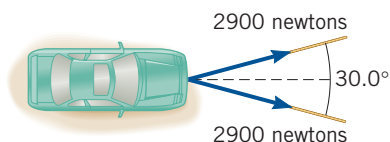

PROBLEM 30

31. **M GO** A jogger travels a route that has two parts. The first is a displacement \vec{A} of 2.50 km due south, and the second involves a displacement \vec{B} that points due east. (a) The resultant displacement $\vec{A} + \vec{B}$ has a magnitude of 3.75 km. What is the magnitude of \vec{B} , and what is the direction of $\vec{A} + \vec{B}$ relative to due south? (b) Suppose that $\vec{A} - \vec{B}$ had a magnitude of 3.75 km. What then would be the magnitude of \vec{B} , and what is the direction of $\vec{A} - \vec{B}$ relative to due south?

32. **M** At a picnic, there is a contest in which hoses are used to shoot water at a beach ball from three directions. As a result, three forces act on the ball, \vec{F}_1 , \vec{F}_2 , and \vec{F}_3 (see the drawing). The magnitudes of \vec{F}_1 and \vec{F}_2 are $F_1 = 50.0$ newtons and $F_2 = 90.0$ newtons. Using a scale drawing and the graphical technique, determine (a) the magnitude of \vec{F}_3 and (b) the angle θ such that the resultant force acting on the ball is zero.

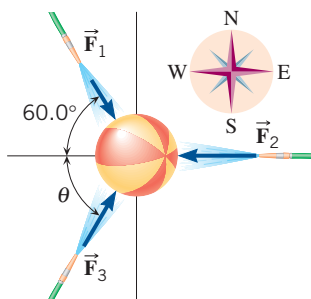

PROBLEM 32

Section 1.7 The Components of a Vector

33. **E GO** A force vector has a magnitude of 575 newtons and points at an angle of 36.0° below the positive x axis. What are (a) the x scalar component and (b) the y scalar component of the vector?

34. **E SSM** Vector \vec{A} points along the $+y$ axis and has a magnitude of 100.0 units. Vector \vec{B} points at an angle of 60.0° above the $+x$ axis and has a magnitude of 200.0 units. Vector \vec{C} points along the $+x$ axis and has a magnitude of 150.0 units. Which vector has (a) the largest x component and (b) the largest y component?

35. **E** Soccer player #1 is 8.6 m from the goal (see the drawing). If she kicks the ball directly into the net, the ball has a displacement labeled \vec{A} . If, on the other hand, she first kicks it to player #2, who then kicks it into the net, the ball undergoes two successive displacements, \vec{A}_y and \vec{A}_x . What are the magnitudes and directions of \vec{A}_x and \vec{A}_y ?

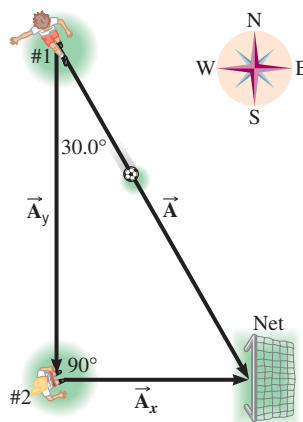

PROBLEM 35

36. **E GO** The components of vector \vec{A} are A_x and A_y (both positive), and the angle that it makes with respect to the positive x axis is θ . Find the angle θ if the components of the displacement vector \vec{A} are (a) $A_x = 12$ m and $A_y = 12$ m, (b) $A_x = 17$ m and $A_y = 12$ m, and (c) $A_x = 12$ m and $A_y = 17$ m.

37. **E** During takeoff, an airplane climbs with a speed of 180 m/s at an angle of 34° above the horizontal. The speed and direction of the airplane constitute a vector quantity known as the velocity. The sun is shining directly overhead. How fast is the shadow of the plane moving along the ground? (That is, what is the magnitude of the horizontal component of the plane's velocity?)

38. **E SSM** The x vector component of a displacement vector \vec{r} has a magnitude of 125 m and points along the negative x axis. The y vector component has a magnitude of 184 m and points along the negative y axis. Find the magnitude and direction of \vec{r} . Specify the direction with respect to the negative x axis.

39. **E** Your friend has slipped and fallen. To help her up, you pull with a force \vec{F} , as the drawing shows. The vertical component of this force is 130 newtons, and the horizontal component is 150 newtons. Find (a) the magnitude of \vec{F} and (b) the angle θ .

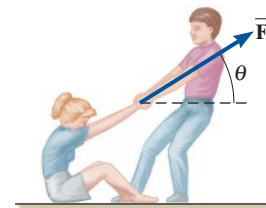

PROBLEM 39

40. **M GO** Two racing boats set out from the same dock and speed away at the same constant speed of 101 km/h for half an hour (0.500 h), the blue boat headed 25.0° south of west, and the green boat headed 37.0° south of west. During this half hour (a) how much farther west does the blue boat travel, compared to the green boat, and (b) how much farther south does the green boat travel, compared to the blue boat? Express your answers in km.

41. **M SSM MMH CHALK** The magnitude of the force vector \vec{F} is 82.3 newtons. The x component of this vector is directed along the $+x$ axis and has a magnitude of 74.6 newtons. The y component points along the $+y$ axis. (a) Find the direction of \vec{F} relative to the $+x$ axis. (b) Find the component of \vec{F} along the $+y$ axis.

Section 1.8 Addition of Vectors by Means of Components

42. **E SSM** Consult Multiple-Concept Example 9 in preparation for this problem. A golfer, putting on a green, requires three strokes to "hole the ball." During the first putt, the ball rolls 5.0 m due east. For the second putt, the ball travels 2.1 m at an angle of 20.0° north of east. The third putt is 0.50 m due north. What displacement (magnitude and direction relative to due east) would have been needed to "hole the ball" on the very first putt?

43. **E CHALK** The three displacement vectors in the drawing have magnitudes of $A = 5.00$ m, $B = 5.00$ m, and $C = 4.00$ m. Find the resultant (magnitude and directional angle) of the three vectors by means of the component method. Express the directional angle as an angle above the positive or negative x axis.

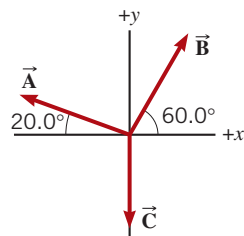

PROBLEM 43

44. **E MMH** Multiple-Concept Example 9 reviews the concepts that play a role in this problem. Two forces are applied to a tree stump to pull it out of the ground. Force \vec{F}_A has a magnitude of 2240 newtons and points 34.0° south of east, while force \vec{F}_B has a magnitude of 3160 newtons and points due south. Using the component method, find the magnitude and direction of the resultant force $\vec{F}_A + \vec{F}_B$ that is applied to the stump. Specify the direction with respect to due east.

45. **E GO** A baby elephant is stuck in a mud hole. To help pull it out, game keepers use a rope to apply a force \vec{F}_A , as part *a* of the drawing shows. By itself, however, force \vec{F}_A is insufficient. Therefore, two additional forces \vec{F}_B and \vec{F}_C are applied, as in part *b* of the drawing. Each of these additional forces has the same magnitude F . The magnitude of the resultant force acting on the elephant in part *b* of the drawing is k times larger than that in part *a*. Find the ratio F/F_A when $k = 2.00$.

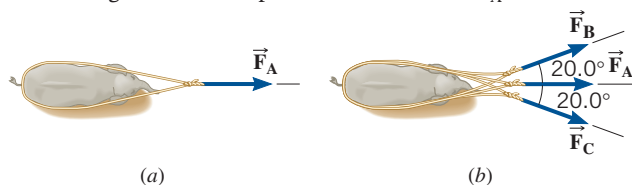

PROBLEM 45

46. **E** Displacement vector \vec{A} points due east and has a magnitude of 2.00 km. Displacement vector \vec{B} points due north and has a magnitude of 3.75 km. Displacement vector \vec{C} points due west and has a magnitude of 2.50 km. Displacement vector \vec{D} points due south and has a magnitude of 3.00 km. Find the magnitude and direction (relative to due west) of the resultant vector $\vec{A} + \vec{B} + \vec{C} + \vec{D}$.

47. **E** Multiple-Concept Example 9 provides background pertinent to this problem. The magnitudes of the four displacement vectors shown in the drawing are $A = 16.0$ m, $B = 11.0$ m, $C = 12.0$ m, and $D = 26.0$ m. Determine the magnitude and directional angle for the resultant that occurs when these vectors are added together.

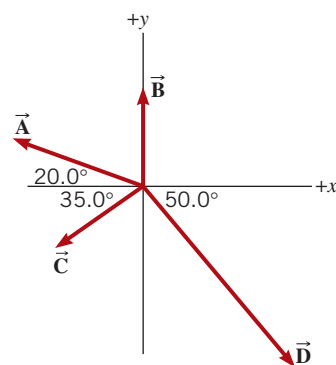

PROBLEM 47

48. **M GO** Two geological field teams are working in a remote area. A global positioning system (GPS) tracker at their base camp shows the location of the first team as 38 km away, 19° north of west, and the second team as 29 km away, 35° east of north. When the first team uses its GPS to check the position of the second team, what does the GPS give for the second team's (a) distance from them and (b) direction, measured from due east?

49. **M SSM** A sailboat race course consists of four legs, defined by the displacement vectors \vec{A} , \vec{B} , \vec{C} , and \vec{D} , as the drawing indicates. The magnitudes of the first three vectors are $A = 3.20$ km, $B = 5.10$ km, and $C = 4.80$ km. The finish line of the course coincides with the starting line. Using the data in the drawing, find the distance of the fourth leg and the angle θ .

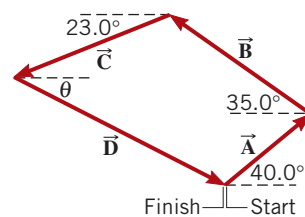

PROBLEM 49

50. **M** Multiple-Concept Example 9 deals with the concepts that are important in this problem. A grasshopper makes four jumps. The displacement vectors are (1) 27.0 cm, due west; (2) 23.0 cm, 35.0° south of west; (3) 28.0 cm, 55.0° south of east; and (4) 35.0 cm, 63.0° north of east. Find the magnitude and direction of the resultant displacement. Express the direction with respect to due west.

51. **M** The route followed by a hiker consists of three displacement vectors \vec{A} , \vec{B} , and \vec{C} . Vector \vec{A} is along a measured trail and is 1550 m in a direction 25.0° north of east. Vector \vec{B} is not along a measured trail, but the hiker uses a compass and knows that the direction is 41.0° east of south. Similarly, the direction of vector \vec{C} is 35.0° north of west. The hiker ends up back where she started. Therefore, it follows that the resultant displacement is zero, or $\vec{A} + \vec{B} + \vec{C} = \mathbf{0}$. Find the magnitudes of (a) vector \vec{B} and (b) vector \vec{C} .

Additional Problems

Online

52. **E** A monkey is chained to a stake in the ground. The stake is 3.00 m from a vertical pole, and the chain is 3.40 m long. How high can the monkey climb up the pole?

53. **M** A car drives from its initial position for 150 km in a direction that is 20° north of east and stops. The car then drives due north for 125 km and stops again. After the car comes to rest the second time, what is the displacement (a) magnitude and (b) direction of the car from its initial position? State your direction relative to due East.

54. **E** An ocean liner leaves New York City and travels 18.0° north of east for 155 km. How far east and how far north has it gone? In other words, what are the magnitudes of the components of the ship's displacement vector in the directions (a) due east and (b) due north?

55. **E GO** A pilot flies her route in two straight-line segments. The displacement vector \vec{A} for the first segment has a magnitude of 244 km and a direction 30.0° north of east. The displacement vector \vec{B} for the second segment has a magnitude of 175 km and a direction

due west. The resultant displacement vector is $\vec{R} = \vec{A} + \vec{B}$ and makes an angle θ with the direction due east. Using the component method, find the magnitude of \vec{R} and the directional angle θ .

56. **M SSM** Vector \vec{A} has a magnitude of 6.00 units and points due east. Vector \vec{B} points due north. (a) What is the magnitude of \vec{B} , if the vector $\vec{A} + \vec{B}$ points 60.0° north of east? (b) Find the magnitude of $\vec{A} + \vec{B}$.

57. **M GO** Three forces act on an object, as indicated in the drawing. Force \vec{F}_1 has a magnitude of 21.0 newtons (21.0 N) and is directed 30.0° to the left of the $+y$ axis. Force \vec{F}_2 has a magnitude of 15.0 N and points along the $+x$ axis. What must be the magnitude and direction (specified by the angle θ in the drawing) of the third force \vec{F}_3 such that the vector sum of the three forces is 0 N?

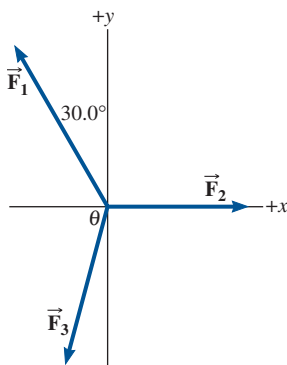

PROBLEM 57

58. **M CHALK** You live in the building on the left in the drawing, and a

friend lives in the other building. The two of you are having a discussion about the heights of the buildings, and your friend claims that the height of his building is more than 1.50 times the height of yours. To resolve the issue you climb to the roof of your building and estimate that your line of sight to the top edge of the other building makes an angle of 21° above the horizontal, whereas your line of sight to the base of the other building makes an angle of 52° below the horizontal. Determine the ratio of the height of the taller building to the height of the shorter building. State whether your friend is right or wrong.

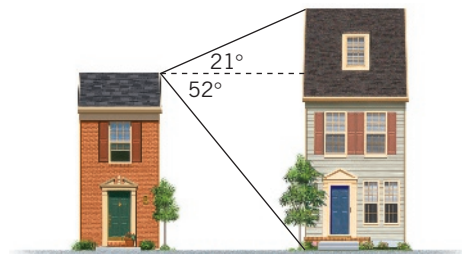

PROBLEM 58

Physics in Biology, Medicine, and Sports

59. **E BIO 1.3** Azelastine hydrochloride is an antihistamine nasal spray. A standard size container holds one fluid ounce (oz) of the liquid. You are searching for this medication in a European drugstore and are asked how many milliliters (mL) there are in one fluid ounce. Using the following conversion factors, determine the number of milliliters in a volume of one fluid ounce: 1 gallon (gal) = 128 oz, 3.785×10^{-3} cubic meters (m^3) = 1 gal, and $1 \text{ mL} = 10^{-6} m^3$.

60. **E BIO 1.3** The volume of liquid flowing per second is called the volume flow rate Q and has the dimensions of $[L]^3/[T]$. The flow rate of a liquid through a hypodermic needle during an injection can be estimated with the following equation:

$$Q = \frac{\pi R^n (P_2 - P_1)}{8\eta L}$$

The length and radius of the needle are L and R , respectively, both of which have the dimension $[L]$. The pressures at opposite ends of the needle are P_2 and P_1 , both of which have the dimensions of $[M]/\{[L][T]^2\}$. The symbol η represents the viscosity of the liquid and has the dimensions of $[M]/\{[L][T]\}$. The symbol π stands for pi and, like the number 8 and the exponent n , has no dimensions. Using dimensional analysis, determine the value of n in the expression for Q .

61. **E BIO 1.3** During their lifetime, a person will consume approximately 1.2×10^4 gallons of water. An Olympic-size swimming pool, which has a volume of 2.5 million liters (L), can provide a lifetime of water for how many people? Recall that 1 gallon (gal) = $3.785 \times 10^{-3} m^3$, and $1 \text{ mL} = 10^{-6} m^3$.

62. **E BIO 1.3** Deoxyribonucleic acid, or DNA, is a molecule composed of two chains that wrap around each other to form a double helix, as the figure shows. DNA carries the genetic information for the growth and development of all known organisms. If you were to uncoil all of the DNA chains in a human body and lay them end-to-end, they would stretch for a distance of $1.6 \times 10^{13} \text{ m}$. What is this

distance in miles? For comparison, the average distance from Earth to Pluto is about 3.7 billion miles.



PROBLEM 62

2.2–2.6 nm

PublicDomainPictures/Pixabay

63. **M BIO 1.3** An owl's keen eyesight is not the only ability that assists them in locating prey. They also have exceptional hearing. Take the barn owl, for example. Their entire head is designed to focus in on low frequency sounds. They have a dish-shaped face that collects and amplifies sound in much the same way a dish antenna collects electromagnetic signals from orbiting satellites (see images below). Their ears are hidden behind feathers on each side of their head behind their eyes. The position of their ear openings is not symmetrical, as their left ear is slightly higher than their right one. This asymmetry allows them to determine if a source of sound is above or below their line of sight. Furthermore, they use a technique known as *triangulation* to pinpoint the location of prey in front of them. Consider the distance between the owl's ears to correspond to the base of a triangle, with the long sides extending from each ear to a mouse located some distance away (see figure). If the mouse is directly in front of

the owl, then the time it takes the sound to travel from the mouse to its left and right ear will be the same. However, if the mouse is not directly in front, such as in the figure, then the sound will reach the owl's left and right ears at different times. The owl's auditory system is extremely sensitive to this time difference. In fact, it can detect a time difference between its left and right ear of 30 millionths of a second! The owl turns its head until the sound difference is eliminated, which indicates its prey is directly in front.



The figure shows an example of the mouse being located to the left of the owl's forward direction (dashed line). In this case, the sound created by the mouse would reach the owl's left ear a fraction of a second sooner than it reaches the right ear. Based on the information shown in the figure (not to scale) calculate the distance between the owl's ears (x).

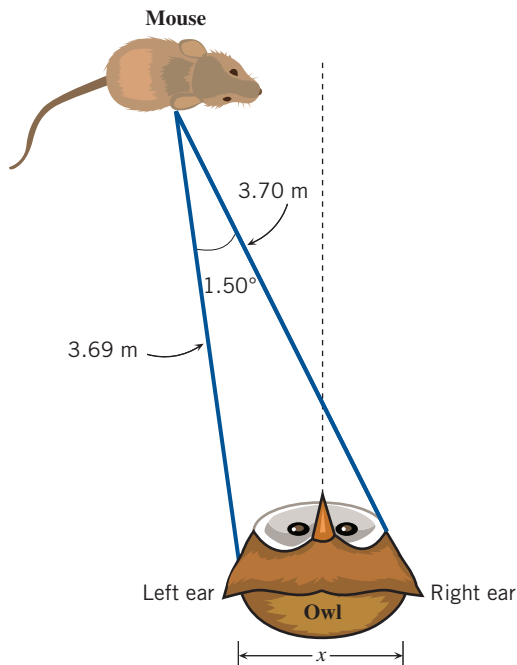

PROBLEM 63

64. **E BIO 1.3** The total surface area of the United States is $9.6 \times 10^6 \text{ km}^2$. Seventy-four percent of this land can support spiders. Given that there are approximately 5.0×10^4 spiders per acre, how many spiders are there in the United States? Recall that $1 \text{ acre} = 0.004 \text{ km}^2$.

65. **M BIO 1.4** Scoliosis is a common disease of the spine, where the spine is not straight, but forms an "S" or "C" shape while viewing a patient from the front. One of the most widely used indicators of scoliosis is a measurement of the Cobb angle (a), as it is a quantitative measure of the spinal curvature. The Cobb angle is calculated directly on X-ray radiographs of the spine (see photo). To determine the Cobb angle, the health professional must decide which two vertebrae are at each end of the deformity. They correspond to the two vertebrae that are rotated the most from a vertical position. In the following sample X-ray, these are shown with red arrows. Lines are then drawn (solid blue) along the endplates of these vertebrae until they intersect as shown, forming the Cobb angle a . In this example, an isosceles triangle is formed, where the two equivalent sides have a length h , and the third side has a length of $0.65h$. If the angle θ in the figure has a value of 38° , what is the value of the Cobb angle, a ?

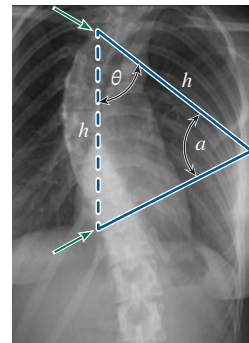

Case courtesy of A.Prof Frank Gaillard, Radiopaedia.org. rID: 49374

PROBLEM 65

Concepts and Calculations Problems

Online

This chapter has presented an introduction to the mathematics of trigonometry and vectors, which will be used throughout the text. In this section we apply some of the important features of this mathematics,

and review some concepts that can help in anticipating some of the characteristics of the numerical answers.

66. M CHALK The figure shows two displacement vectors \vec{A} and \vec{B} . Vector \vec{A} points at an angle of 22.0° above the x axis and has an unknown magnitude. Vector \vec{B} has an x component $B_x = 35.0$ m and has an unknown y component B_y . These two vectors are equal. *Concepts:* (i) What does the condition that vector \vec{A} equals \vec{B} imply about the magnitudes and directions of the vectors? (ii) What does the condition that vector \vec{A} equals \vec{B} imply about the x and y components of the vectors? *Calculations:* Find the magnitude of \vec{A} and the value of B_y .

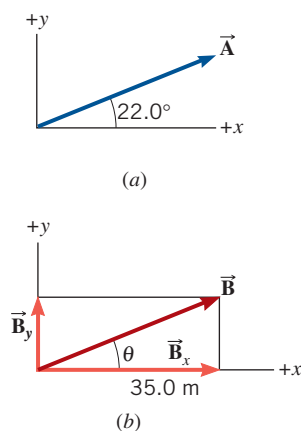

PROBLEM 66

67. M CHALK SSM The figure shows three displacement vectors \vec{A} , \vec{B} , and \vec{C} . These vectors are arranged in tail-to-head fashion, and they

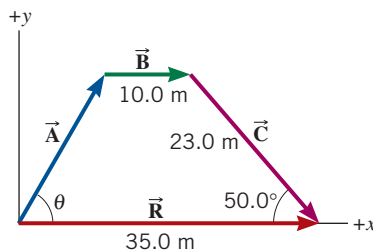

PROBLEM 67

add together to give a resultant displacement \vec{R} , which lies along the x axis. Note that the vector \vec{B} is parallel to the x axis. *Concepts:* (i) How is the magnitude of \vec{A} related to its scalar components A_x and A_y ? (ii) Do any of the vectors in the figure have a zero value for either their x or y components? (If so, which ones?) (iii) What does the fact that \vec{A} , \vec{B} , and \vec{C} add together to give \vec{R} tell you about the components of these vectors? *Calculations:* What is the magnitude of the vector \vec{A} and its directional angle θ ?

Team Problems

Online

68. E BIO WS T Recovering a Downed Eagle. You are on a road that runs east and west, and another member of your team is on the same road, 1.20 km east of you. Someone reported seeing an eagle strike a wire and eventually go down somewhere in a dense forest north of the road. Your objective is to rescue the downed eagle. The bird is fitted with a transmitter, and you have a detector that indicates that it is located at a distance of 6.00×10^2 m from you. The team member located 1.20 km east of you has a similar detector that indicates that the eagle is 9.00×10^2 m away from them. Note that neither detector gives directional information. **(a)** Assuming a straight-line path, determine the direction you must go in order to find the eagle. **(b)** Assuming you want to minimize your walking distance in the thick forest, how should you proceed? Find the minimum distance traveled in the forest.

69. E BIO WS T Focusing a Gamma Knife. A gamma knife is a medical device used to deliver high intensity radiation to a tumor inside the human body while minimizing damage to the surrounding tissue. The device directs multiple radiation beams through the same point (e.g., at the position of a tumor) so that the intensity in the volume where the beams intersect is extremely high. Suppose the position of a tumor relative to the origin of an xy coordinate system is represented by a vector of magnitude 32.5 cm that makes an angle of $\theta_0 = +76.4^\circ$ with respect to the $+x$ axis. If two radiation sources are located on the x axis at positions $x_1 = +10.7$ cm and $x_2 = -14.3$ cm, at what angles relative to the $+x$ axis must the radiation beams from these two sources be directed so that they intersect at the tumor?

70. M T The Waterfall. You and your team are exploring a river in South America when you come to the bottom of a tall waterfall. You estimate the cliff over which the water flows to be about 100 feet tall. You have to choose between climbing the cliff or backtracking and taking another route, but climbing the cliff would cut two hours off of your trip. There is only one experienced climber in the group: she would climb the cliff alone and drop a rope over the edge to lift supplies and allow the others to climb without packs. The climber estimates it will take her 45 minutes to get to the top. However, you

are concerned that the rope might be too short to reach the bottom of the cliff (it is exactly 30.0 m long). If it is too short, she'll have to climb back down (another 45 minutes) and you will be too far behind schedule to get to your destination before dark. As you contemplate how to determine whether the rope is long enough, you notice that the late afternoon shadow of the cliff grows as the sun descends over its edge. You suddenly remember your trigonometry. You measure the length of the shadow from the base of the cliff to the shadow's edge (144 ft), and the angle subtended between the base and top of the cliff measured from the shadow's edge. The angle is 38.1° . Do you send the climber, or start backtracking to take another route?

71. M T The Weather Monitor. Your South American expedition splits into two groups: one that stays at home base, and yours that goes off to set up a sensor that will monitor precipitation, temperature, and sunlight through the upcoming winter. The sensor must link up to a central communications system at base camp that simultaneously uploads the data from numerous sensors to a satellite. In order to set up and calibrate the sensor, you will have to communicate with base camp to give them specific location information. Unfortunately, the group's communication and navigation equipment has dwindled to walkie-talkies and a compass due to a river-raft mishap, which means your group must not exceed the range of the walkie-talkies (3.0 miles). However, you do have a laser rangefinder to help you measure distances as you navigate with the compass. After a few hours of hiking, you find the perfect plateau on which to mount the sensor. You have carefully mapped your path from base camp around lakes and other obstacles: 550.0 m West (W), 275 m S, 750.0 m W, 900.0 m NE, 800.0 m W, and 400.0 m 30.0° W of S. The final leg is due south, 2.20 km up a constant slope and ending at a plateau that is 320.0 m above the level of base camp. **(a)** How far are you from base camp? Will you be able to communicate with home base using the walkie-talkies? **(b)** What is the geographical direction from base camp to the sensor (expressed in the form θ° south of west, etc.)? **(c)** What is the angle of inclination from base camp to the detector?