

Water must be controlled in order to prevent leakage, which is the penetration of water through a building assembly. Water intrusion is the most common detailing problem encountered in buildings. For water to penetrate through a building assembly, three conditions must all occur at the same time:

1. There must be an opening through the assembly.
2. There must be water present at the opening.
3. There must be a force to move the water through the opening.

If any one of these three conditions is not met, water will not penetrate the assembly. In developing any exterior detail, therefore, the designer can pursue one or more of three strategies:

1. Try to eliminate openings in building assemblies.
2. Try to keep water away from openings in building assemblies.
3. Try to neutralize forces that move water through openings in building assemblies.

Complete success in any one of these three strategies will result in the complete elimination of water leaks, but in detailing it is sometimes necessary to pursue two of these strategies or even all three of them at the same time. This approach gives added security in case one of the strategies fails as a result of poor workmanship or building deterioration. Each of these strategies is considered briefly here with a corresponding list of detail patterns that relate to each. All of the patterns listed are explained later in this chapter.

1. Eliminating Openings in Building Assemblies

Every building is full of openings. A shingled roof has an opening under each shingle. A wall has cracks around windows and doors, and around joints between the units of material from which the wall is made. Additional cracks and holes may form as the building ages and deteriorates. The designer can attempt to eliminate all these openings by using preformed gaskets and sealants; however, this is an unreliable strategy for the life cycle performance of the building. Gaskets may not seal securely if they are the wrong size or resiliency, or if the surfaces they touch are rough or unclean. Sealants may fail to adhere properly if the materials to which they are applied are not scrupulously clean and properly primed, or if the installer does not compress the sealant fully into the seam. Both sealants and gaskets can deteriorate from weathering and

from the flexing and stretching they may undergo as the building ages. A building envelope that relies on sealants and gaskets alone for watertightness will leak sooner or later. Even a small defect in a sealant or gasket that is exposed to the weather can leak very large amounts of water, just as a small hole in a bathtub can create a very large puddle.

Sealants and preformed gaskets are still extremely useful as components of an overall strategy for making a building envelope watertight. Therefore, it is important to know how to detail sealant joints and gasket joints correctly and how to incorporate them into more complex schemes for controlling water penetration. The detail pattern that relates to eliminating openings in building assemblies is:

Sealant Joints and Gaskets (p. 36)

2. Keeping Water Away from Openings in Building Assemblies

There are a number of effective ways to keep water away from openings. Often it is useful to keep most water away from an opening simply to reduce the volume of water that must be dealt with at the opening itself. In many cases we can easily and securely keep all water away from an opening.

The detail patterns that relate to keeping water away from openings in building assemblies are the following:

Wash (p. 7)

Overlap (p. 12)

Overhang and Drip (p. 15)

Drain and Weep (p. 18)

Ventilated Cold Roof (p. 22)

Foundation Drainage (p. 24)

3. Neutralizing Forces That Move Water through Openings in Building Assemblies

There are five forces that can move water through an opening in a wall or a roof: (1) gravity, (2) surface tension, (3) capillary action, (4) momentum, and (5) air pressure differentials. In most cases, it is surprisingly easy to detail a building assembly so that all five of these forces are neutralized, and the most secure strategies for keeping water out of a building are based on this approach.

The force of gravity is neutralized by two previously encountered detail patterns useful in keeping water away from openings in buildings:

Wash (p. 7)

Overlap (p. 12)

Surface tension, a force that causes water to cling to the underside of a surface where it can run into an opening, is neutralized by:

Overhang and Drip (p. 15)

The patterns for neutralizing the other three forces are the following:

Moisture Break (p. 25)

Capillary Break (p. 26)

Labyrinth (p. 28)

Rainscreen Assembly and Pressure

Equalization (p. 29)

Upstand (p. 34)

The capillary break neutralizes capillary action. The labyrinth neutralizes momentum, and the rainscreen assembly and the upstand neutralize air pressure differentials. By combining these seven patterns in each exterior joint of a building, we can make a building entirely waterproof.

When conceived as a well-coordinated group, these features combine to form the water control layer of the building envelope. The designer should be able to draw an uninterrupted line in plan and section representing the water control layer. A building with a continuous water control layer is entirely waterproof.



Wash

A *wash* is the slope given to a surface to drain water away from vulnerable areas of a building. In general, every external, nearly horizontal surface of a building should have a wash. More permeable materials should have a steeper slope to shed water more quickly.

1. A window or door sill, whether made of stone, concrete, wood, or metal, always has a wash to keep water from accumulating next to the door or sash. A minimum slope for this type of wash is about 1 in. per foot (1:10 or 1:12). A steeper slope drains water faster and is more secure, because the more quickly water is removed from a surface, the less time it has to leak through. It is also more difficult for wind to drive water up a steeper slope.

2. The wash on this concrete chimney cap keeps water away from the vulnerable crack between the clay flue tile and the concrete. The slope should be at least 1:12. The outer edge of the cap should have a thickness of at least 3 in. (75 mm) to discourage cracking of the concrete, not the feather edge that is commonly used (see *Clean Edge*, Chapter 12). The cricket on the upslope side of the chimney consists of two washes that divert water around the shaft of the chimney.

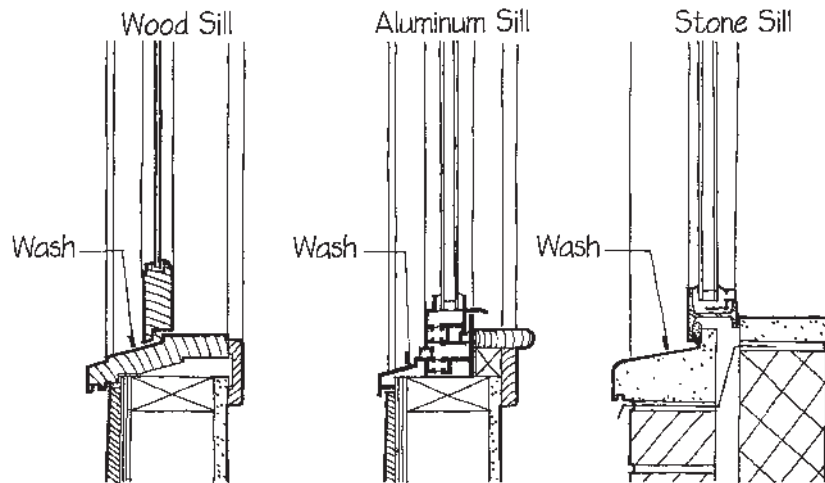

1. Washes on Window Sills

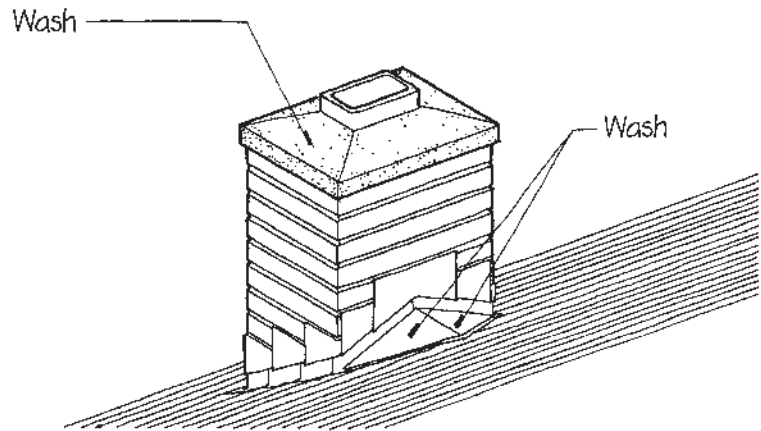

2. Wash on Chimney Cap and Cricket

3. The coping on a building parapet has a wash to keep standing water away from the seams in the parapet. Usually, the wash drains toward the roof to minimize water staining of building façades. The cant strip at the base of the parapet slopes steeply toward the roof membrane to direct water away from the joint between the parapet and the roof deck.

4. The bottom surface in a horizontal joint between wall panels should have a wash to drain water to the outside. Even if the joint will be closed at the outside face with sealant, the wash should be provided to discourage leaking if the sealant should fail.

5. The sloping roof is a special case of the wash. A shingled roof will not shed water unless it has a considerable slope. If the slope were too shallow, water would linger on the roof, flow around and under the shingles, and penetrate the gaps beneath. Each type of shingle material has its own recommended minimum slope. A slope steeper than the minimum is advisable on exposed sites where rain is often driven against the building by wind. A good rule of thumb is to avoid roof slopes less than 4:12. Wood shingles, asphalt shingles, and unsoldered metal roofing can function on a slope as shallow as 3:12 with a special underlayment (consult appropriate literature from trade associations or manufacturers for more information). Steeper slopes shed water faster and thus are less prone to problems; however, they may be more expensive because the roof area is increased, and workers will have greater difficulty moving about the steeper surface. Many roofing materials can be installed at a very steep slope, even on vertical surfaces.

6. So-called flat roofs are seldom flat. They are given a positive slope toward points where water is removed by roof drains or scuppers, because standing water on a roof can cause deterioration of the roof membrane and even structural collapse. The correct name for “flat” roofs, in fact, is “low-slope” roofs. These roof membranes may be exposed to the sky or may be covered with pavers, vegetated roof treatments, solar panels, and other permeable or discontinuous coverings. Drains in a low-slope roof should be located either at points of maximum structural deflection (usually the midspan of a beam or joist) or

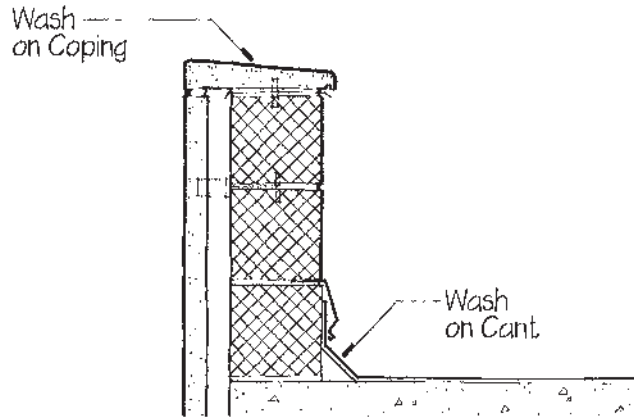

3. Washes at Parapet

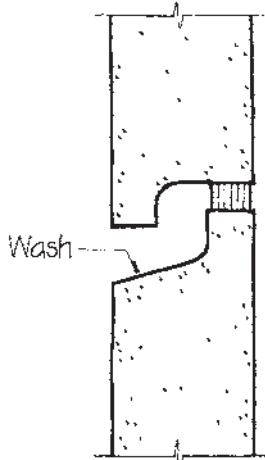

4. Horizontal Panel Joint

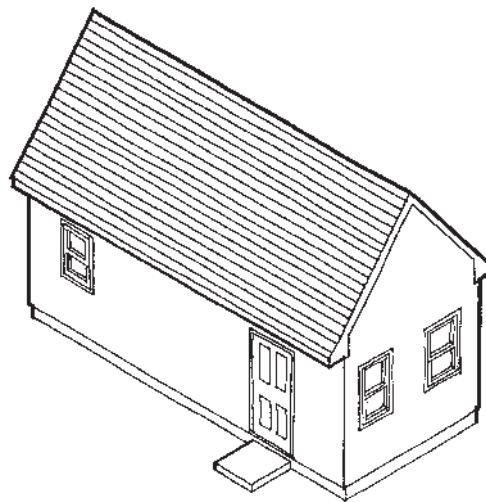

5. Sloping Roof

at low points purposely created by sloping the structure that supports the roof.

Tapered insulation or roof fill should be used if necessary to create an additional slope that will cause water to drain properly from a roof. If a drain is located at a point of maximum structural deflection, the minimum recommended slope for membrane roofs is ¼ in. per foot (1:50), and more slope than this is desirable. If a drain is located at a low point created by sloping a beam, the overall rise along the length of the beam should be at least twice the expected maximum deflection in the beam, plus another ¼ in. per foot (1:100) of the length of the beam, to be sure water cannot be trapped by the curvature of the beam. The detailer should work closely with the structural engineer to design a system of roof drainage that complies with these guidelines. This is especially important if the roof is composed of cambered elements such as precast concrete planks or beams.

It is desirable (and mandatory under some building codes) to provide a complete, independent set of auxiliary roof drains or scuppers to take over in case the primary drains become clogged with debris. The auxiliary drains or scuppers are usually located 2 in. (51 mm) higher in elevation than the primary drains and must be served by their own network of piping.

7. A rooftop terrace is usually drained through open joints between its dead-level paving stones or tiles. The water drops through the joints and is funneled to a system of roof drains by the low-slope roof membrane below. The same recommended slopes apply to this membrane as to any low-slope roof. The terrace paving is held level by small, adjustable-height pedestals that stand on the roof membrane and support the paving units at each intersection. These pedestals are marketed in several proprietary designs and are usually made of plastic.

Vegetated roofs – either extensive or intensive assemblies – are designed to retain some water and drain excess water slowly. The slope and drain considerations are similar to other low-slope roofs; however, the installation application is different. Because the roof or parapet drain serves an overflow function, the drain access is

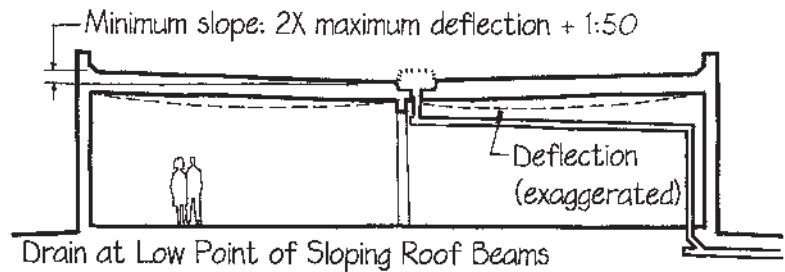
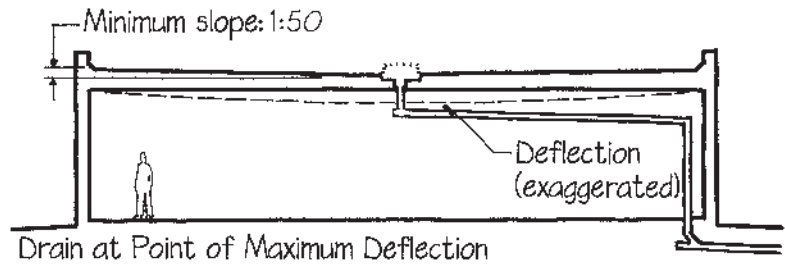
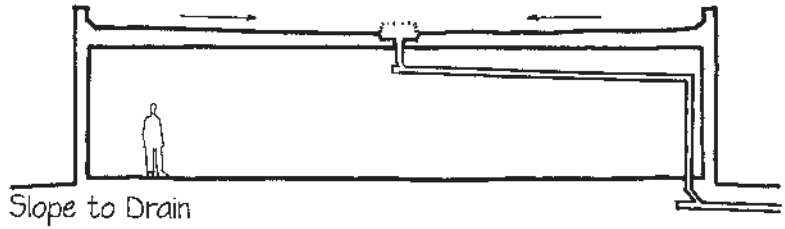

6. Low-Slope Roofs

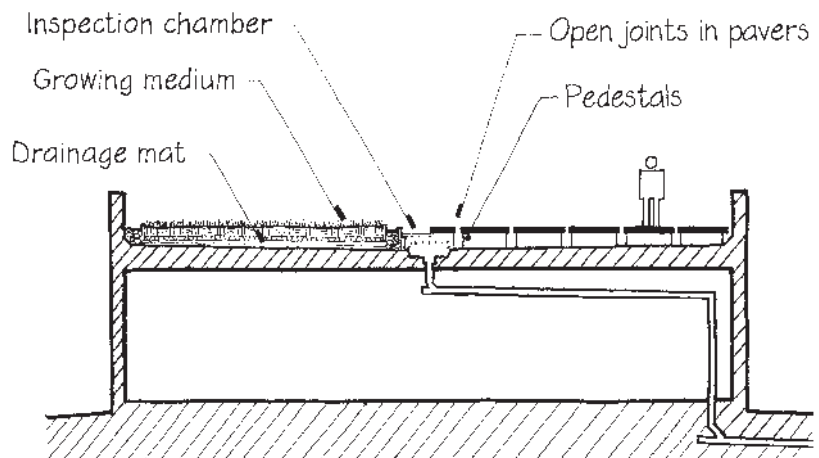

7. Vegetated Roof and Rooftop Terrace

located above the prescribed water line of the drainage and retention mat that serves as the vegetation substrate in the assembly. The drain is protected by a band of

gravel – which is itself separated from the vegetated areas by a profiled strip – and capped with an inspection chamber for routine maintenance operations. ▷

8. Another special case of the wash is indicated on architectural drawings by the note “pitch to drain.” The rain gutter at the eave of a roof is usually pitched (sloped) to drain water toward the nearest downspout. Common slopes used for gutters are 1/8 in. or 1/4 in. per foot (1:100 or 1:50). A steeper slope gives a greater capacity to handle water in a heavy rainstorm, and is recommended where precipitation volumes are large. Rainwater collected by gutters can continue to flow by gravity toward cisterns, planters, or vegetated surfaces, or it can be discharged into a stormwater collection system.



8. Pitched Gutter

9. An industrial or basement floor slab is often pitched toward floor drains to eliminate puddles of standing water. A rule-of-thumb pitch for slab drainage is 1/4 in. per foot (1:50), but to prevent puddles, this should be increased for surfaces that are not very flat, and can be decreased for very smooth surfaces. In the case of a floor or paving, however, pitches should not become too steep, or they will be awkward for pedestrians and vehicles to navigate.

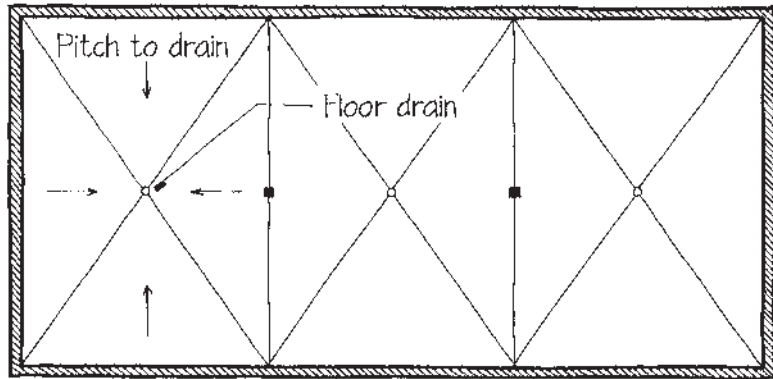

Plan View

Typical: 1:50

9. Floor Slab Pitched to Drain

10. If there is no interior floor drain, a residential garage floor is usually pitched so water dripping off a car will run under the garage door and out. Minimum pitch recommendations are the same as for industrial and basement slabs.

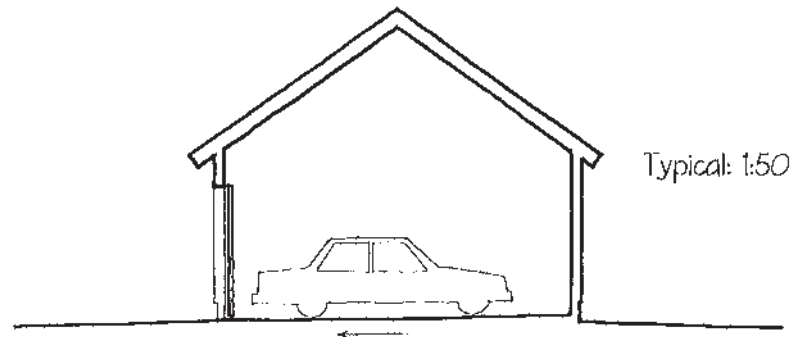

10. Slab Pitched to Drain

11. Roads, driveways, and walks are usually crowned, to shed water in both directions and to avoid puddling. The slope on each side of the crown should be at least 1:200. Parking lots should slope at least 1:100 to shed water, but not more than 5:100.

12. The ground surrounding a building should slope away from the building at a rate of at least 2:100 for at least 6 ft. (1.83 m). This helps keep water from puddling against the foundation and leaking into basements and crawl spaces.

A wash ensures that gravity will act to keep water away from an opening, but its action can be overcome by strong wind currents. Thus, a wash that is contained within a joint is often combined with an air barrier and a pressure equalization chamber to form a rainscreen joint (see *Rainscreen Assembly and Pressure Equalization*, later in this chapter). ■

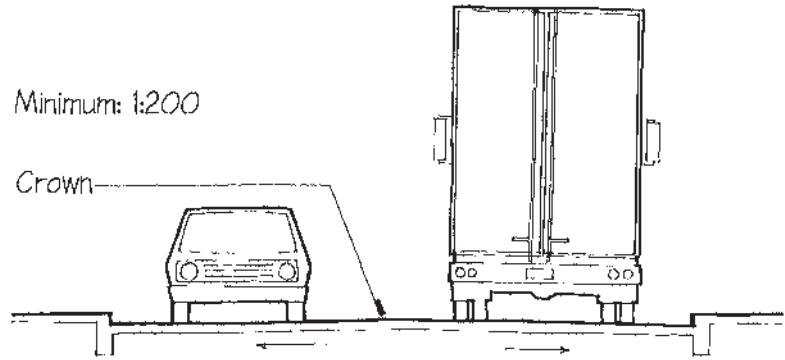

11. Crowned Roadway

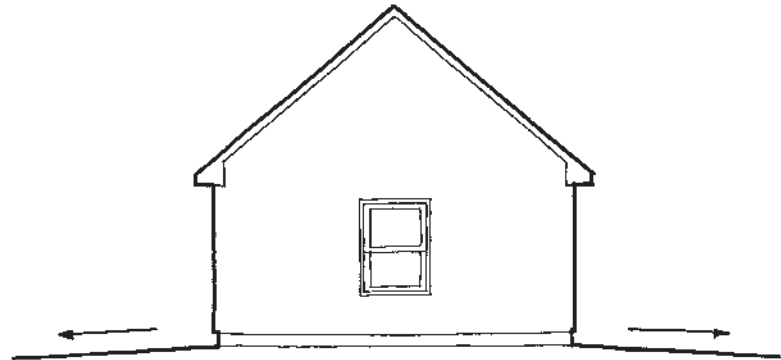

12. Slope Away From Building

Overlap

In an *overlap*, a higher surface is extended over a lower surface so water moved by the force of gravity cannot run behind or beneath them. For an overlapping detail to work, the surfaces must be sloping or vertical. Porous materials need a greater overlap and steeper slope to be effective. The overlap detail pattern is useful to consider when applying off-site panelized and volumetric elements to on-site assemblies.

1. Roof shingles and tiles keep water out by overlapping in such a way that there is no descending path through or between them. Each unit covers a joint between units in the course below. The overlap only works if the roof surface slopes steeply enough so that water runs off before it can find its way around the reverse side of the shingles or tiles to the open cracks beneath.

2. Wood bevel siding sheds water by overlapping each board over the one below. The weak spots in wood siding are the end joints, which should be caulked and flashed to prevent water penetration.

3. Flashings keep water out and protect other materials in a building assembly by overlapping. Flashing is used to create overlap wherever the overlap or slope of base materials is insufficient to prevent water intrusion. This simple Z-flashing of sheet metal or thin plastic keeps water from coming through the crack above a window or door frame.

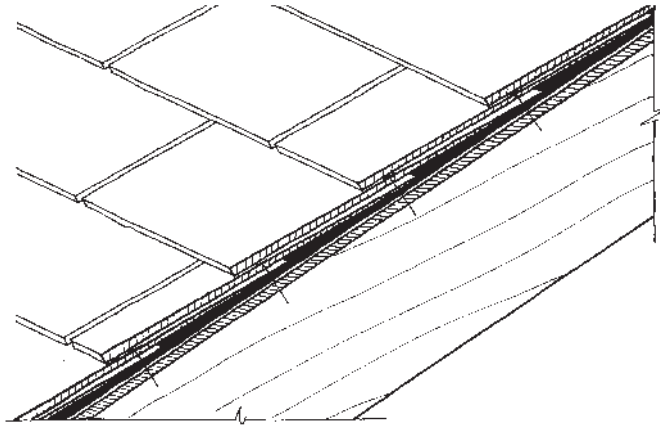

1. Wood Shingle Roofing

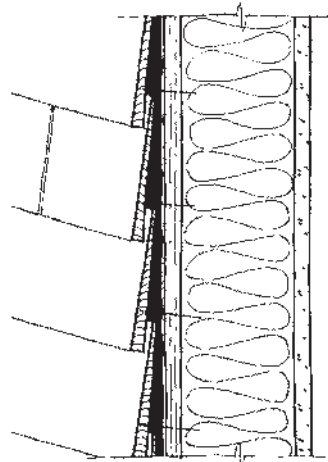

2. Wood Bevel Siding

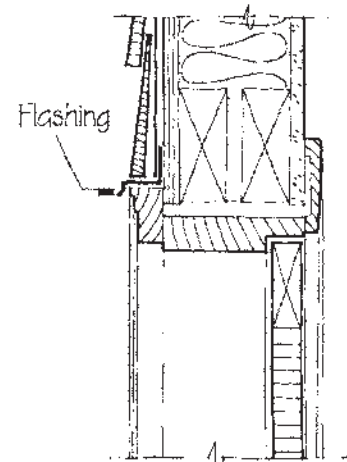

3. Z-Flashing Over Door

4. This lintel flashing in a masonry cavity wall is another example of overlapping. Any water that penetrates the outer brick facing is caught by the metal or synthetic flashing sheet and is conducted through weep holes to the outdoors. Notice the overhang and drip on the outside edge of the flashing. These keep water out of the crack between the flashing and the steel lintel (see *Overhang and Drip*, later in this chapter).

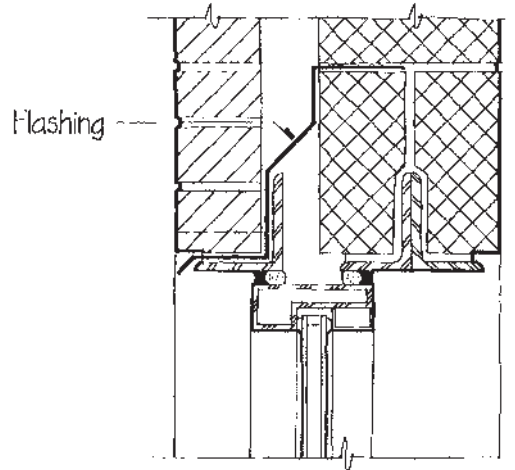

4. Lintel Flashing

5. A reglet is an upward-sloping slot in a vertical surface into which a flashing or the edge of a roof membrane may be inserted. The slope (wash) acts to prevent water from being forced into the vulnerable joint by gravity, and the overlap of the upper lip of the reglet over the flashing keeps water from reaching the joint between the two components. The reglet shown in this drawing is a traditional type that is largely obsolete, but it may still be encountered when older buildings are renovated. It is molded into glazed terra-cotta tiles that are built into a parapet wall by masons. Shims and/or a sealant bead must be inserted into the reglet to hold the flashing or membrane in place.

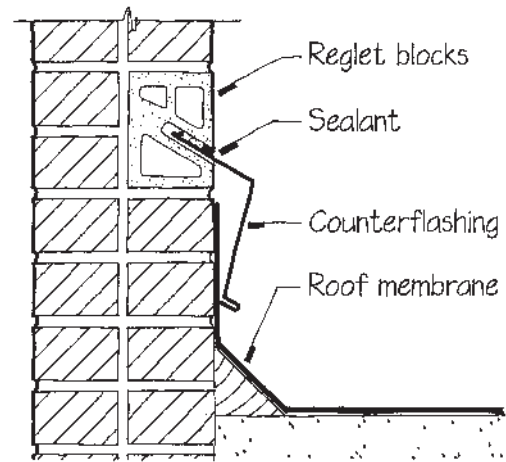

5. Traditional Terra-Cotta Reglet

6. This contemporary reglet is created in a concrete wall or spandrel beam by using a preformed strip of metal or plastic that is nailed lightly to the formwork before the concrete is poured. The opening in the reglet is usually closed temporarily with an adhesive tape or a strip of plastic foam to prevent its being accidentally clogged with concrete. A variety of patented profiles for this type of reglet are intended to interlock securely with a folded edge on the top of the flashing. Careful inspection is needed just prior to concrete pouring to be sure that the reglet is installed right side up.

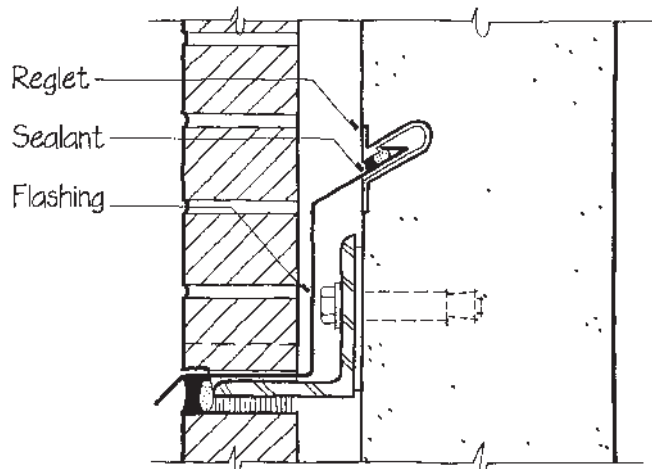

6. Preformed Reglet in Concrete

If a reglet is wetted, water may find its way through by *capillary action*. (see *Capillary Break*, later in this chapter). Capillary action is associated with surface tension, meaning water can travel horizontally or vertically against the force of gravity in spaces within or between materials. A continuous bead of sealant between the flashing and the reglet can be helpful in preventing this water movement. ▷

7. There are also a number of patented designs of surface-mounted reglets made of plastic or metal. A bead of sealant is intended to keep water from behind the reglet. This is somewhat risky, because the success of the detail is entirely dependent on perfect workmanship in installing the sealant and perfect adhesion of the sealant to the wall.

8. The ridge of a standing seam metal roof uses a continuous cap assembly to overlap all of the standing seams, producing covered openings through which water cannot enter, but hot air can escape.

An overlap is generally very effective in preventing entry of water driven by the force of gravity. If wind is allowed to blow through an overlap, however, it may carry water with it. An overlap is useless against standing water, so it cannot be used on a level surface.

9. Panelized wall assemblies provided by off-site fabricators can use substrate and trim materials to overlap and cap the vulnerable seam between individual panels. A prefabricated wall panel – including primary structure, sheathing, insulation, fenestration, and exterior finish materials – simplifies the construction process (see Chapter 13) and reduces potential points of weakness in the building envelope. ■

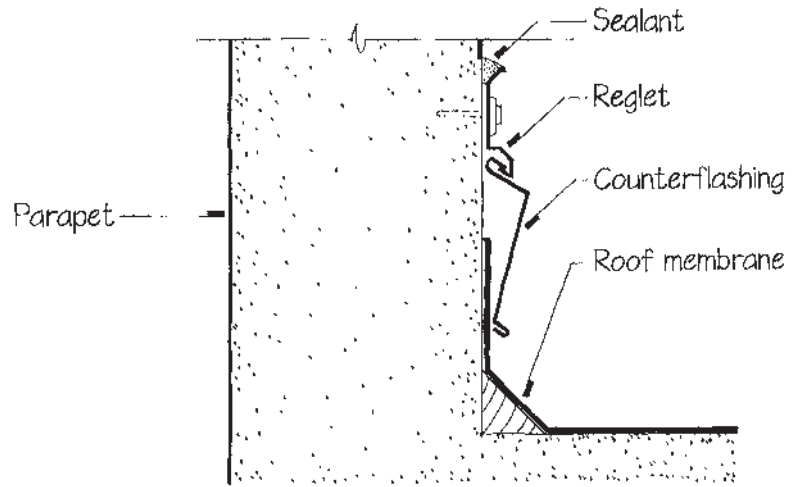

7. Surface-Mounted Reglet

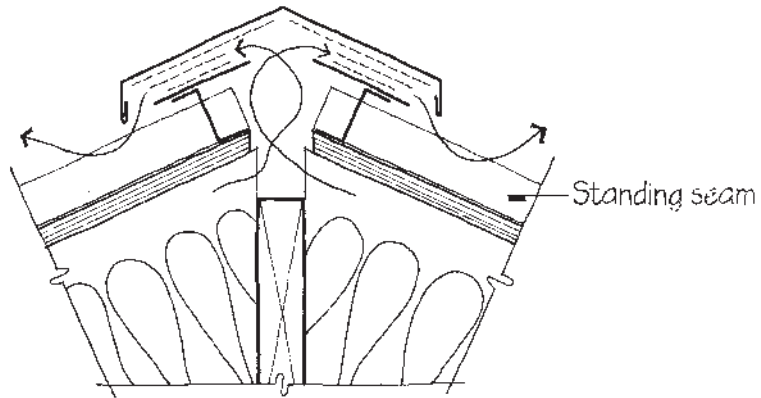

8. Continuous Ridge Vent with Standing Seam Metal Roof

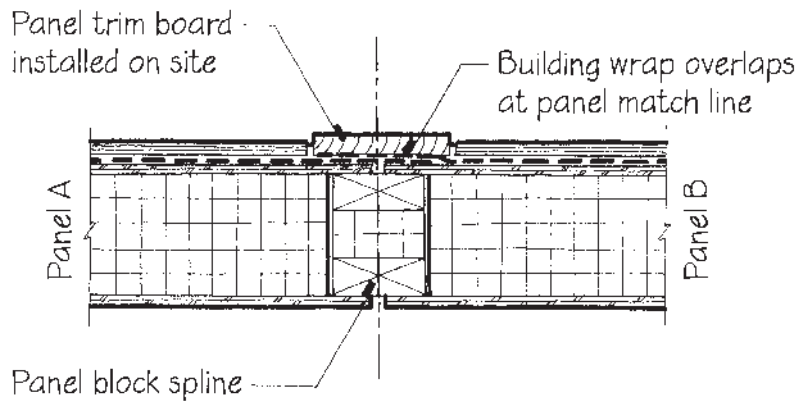

9. Panelized Wall Assemblies



Overhang and Drip

Drops or streams of water adhering to and running down the wall of a building can be kept away from an opening in the wall by a twofold strategy: (1) creating a projecting profile (an *overhang*) just above the opening and (2) creating a continuous groove or ridge in the underside of the projection (a *drip*) so that gravity will pull the adhering water free of the overhang.

1. The size of an overhang is determined by its function. The width of an overhang that protects a seam or joint does not need to extend far from the face of the surface it is protecting. An overhang meant to protect a tall exterior wall must be much wider to be effective. The wider the overhang, the greater the wall area below that will be protected, because wind-driven rain falls at an angle, not straight down.

The angle of falling rain during a storm is difficult to predict accurately, but a good rule of thumb is to add 20 to the wind speed (in mph) at the time of the rain. The sum is the approximate angle from the vertical of the falling rain. Rain falling with a 20 mph (32 kph) wind would fall at an angle of about 40 degrees off of vertical; at 40 mph (64 kph) it would fall at approximately 60 degrees off of vertical. Greater overhang width also moves the splash of the water on the ground below farther from the wall face, decreasing secondary wetting and soiling of the wall surface.

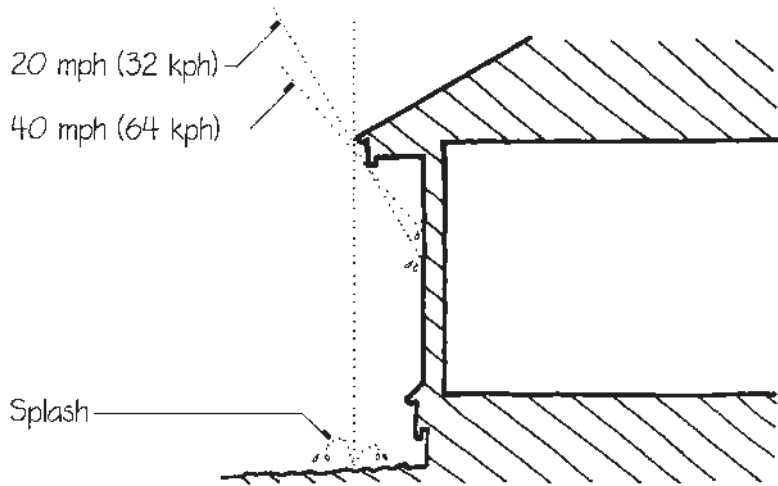

1a. Overhang and Wind-Driven Rain

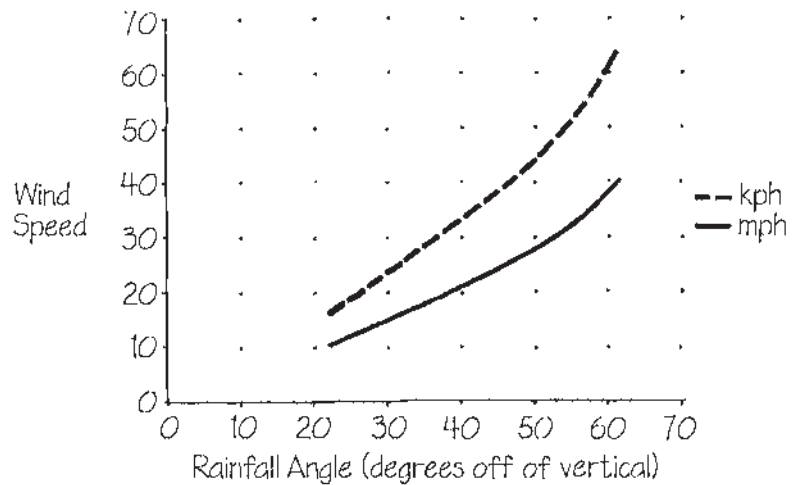

1b. Angle of Wind-Driven Rainfall

2. These are two versions of a door sill detail: one executed entirely in wood and the other in a combination of wood and aluminum components. There are two openings that must be protected in either case: the crack between the door and the sill, and the joint between the sill and the wall of the building. The door cannot fit tightly to the sill because a generous clearance is required to allow free operation of the door. We would certainly weatherstrip this crack, but the weatherstrip is intended only as a barrier to the passage of air (see Chapter 2) and should not be relied upon to prevent water from passing. We would want the installer to bed the sill in sealant, but the sealant work might be imperfect, and it would deteriorate over time. The overhang and drip is a simple, economical, and highly effective detailing element that shows up in many kinds of details.

In these two drawings, we see it used to protect the two openings beneath a door. In the lower part of both these details, the sill overhangs the wall below. In the wood sill detail (2a), the drip is simply a groove milled into the bottom of the wooden sill. The groove must be wide enough and deep enough so that a drop of water cannot bridge it: Usually a width of ¼ in. (6 mm) and a depth of ⅛ in. (3 mm) are about right. In the aluminum sill detail (2b), the drip is formed by the downturned outer edge of the extrusion. In either case, adhering drops of water cannot move across the drip. To do so, they would have to move uphill, against the force of gravity. Therefore, they collect at the outer edge of the drip and fall free. Notice in both cases that the sill has a wash to drain water away from the door.

On the bottom of the door in both details is a second type of overhang and drip that protects the crack between the

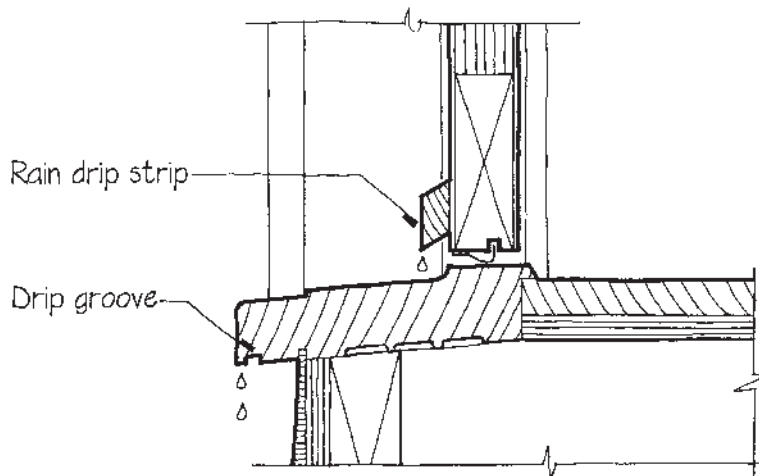

2a. Wood Door Sill

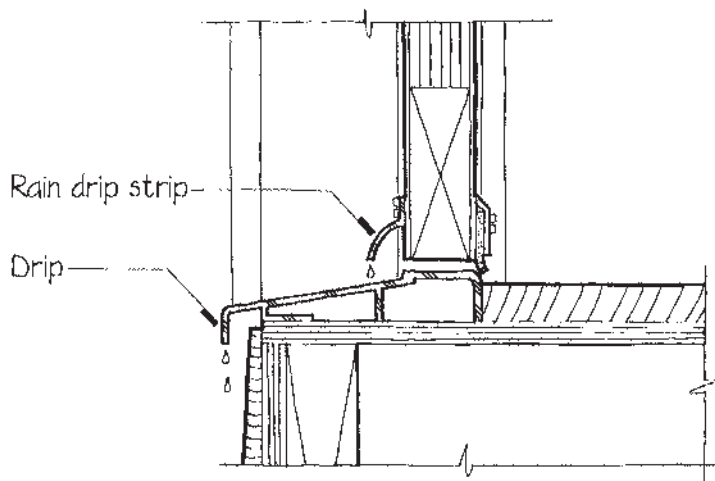

2b. Aluminum Door Sill

door and the sill. The overhang is provided by a wooden or aluminum drip strip that is screwed tightly to the door. The underside of the drip strip is configured so that water must drip free at the outer edge, well clear of the crack between the door and the sill. The top of the drip strip, of course, has a steep wash in each case.

3. Standard exterior details of wood frame buildings contain several examples of the overhang and drip principle. Roof shingles overhang the fascia board and slope upward so that water will drip clear of the joint between the fascia and the shingles. The lower edge of the fascia projects below the horizontal soffit so that water running down the fascia will drip free of the crack between the fascia and the soffit. The whole eave is a large overhang and drip that keeps water off the vulnerable upper edge of the wall and adds some protection to window and door openings. At the base of the wall, a traditional water table detail consists of an overhang and drip designed to keep water out of the crack between the wood wall and the foundation. Whether or not a water table is used, the bottom edge of the siding should be spaced away from the foundation wall to create another overhang and drip.

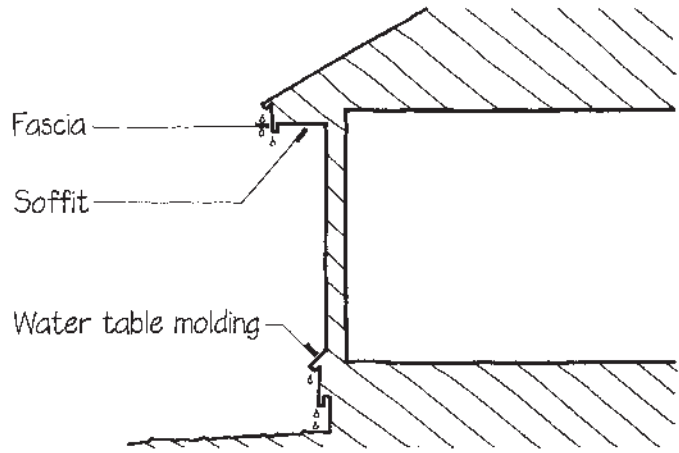

3. Wood Frame Wall

4. The stone or concrete coping atop a masonry parapet wall is sloped toward the inside of the building to help prevent staining and leaking of the outer surface of the wall. A generous overhang and a drip are provided to keep water out of the mortar joint immediately beneath the coping. Additionally, the metal flashing in this mortar joint projects outward and downward to provide another overhang and drip.

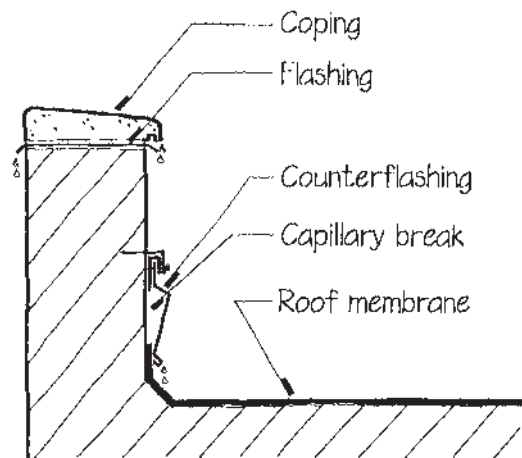

4. Masonry Parapet

The seam between the metal counterflashing and roof membrane, where the roof joins the parapet wall, is potentially troublesome. The counterflashing and roof membrane often fit closely enough that water entering the seam would be pulled into it by capillary action. The overhang and drip in the counterflashing profile keeps the seam dry. As a backup precaution, the counterflashing is also folded out to create a **Capillary Break** (see information later in this chapter). For ease of installation, the counterflashing is often made in two pieces, as shown. The first piece is embedded in the wall by the masons and the second piece is inserted into the first and screwed to it by the roofing installers. ▷

5. A drip should always be provided under the outer edge of an overhanging story of a building. In a wood building, the bottom edge of the siding can usually be projected below the soffit to provide a drip. In a concrete or stone building, a drip groove around the outer edge of the soffit will prevent leakage and staining of the soffit area.

6. Internal flashings in masonry veneers sometimes catch and divert relatively large volumes of water as the mortar joints in the veneer above age and deteriorate. Each flashing should project completely through the outer face of the masonry by roughly $\frac{3}{4}$ in. (19 mm) and turn down at 45 degrees to keep the draining water from wetting the mortarless horizontal joint beneath the flashing. The detailer should resist the urge to recess the outer edge of the flashing into the mortar joint. This might look better than a projecting flashing, but it can lead to serious leakage and deterioration problems beneath the flashing. Flashing is most effective when it overlaps seams in the substrate.

7. A larger-scale overhang and drip in the form of a porch roof or marquee offers the building user the opportunity to leave a door or a window open for ventilation or access even during moderately severe rainstorms.

The problems in making the cracks around exterior doors waterproof are significant: A reasonable solution is to provide a small protective roof above every exterior door in a building. ■

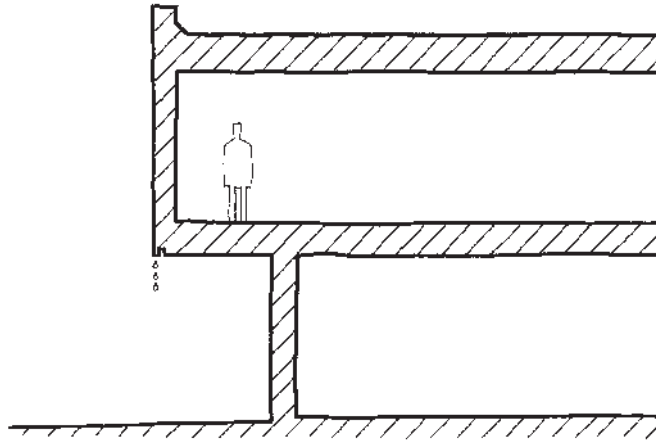

5. Overhanging Story

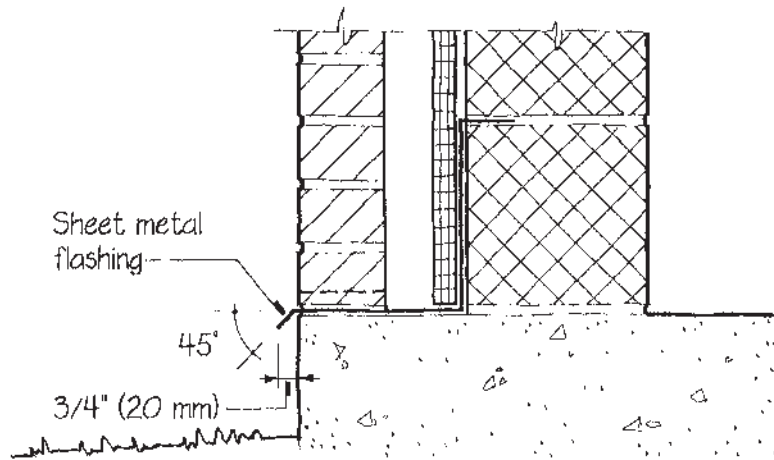

6. Flashing Drip Detail

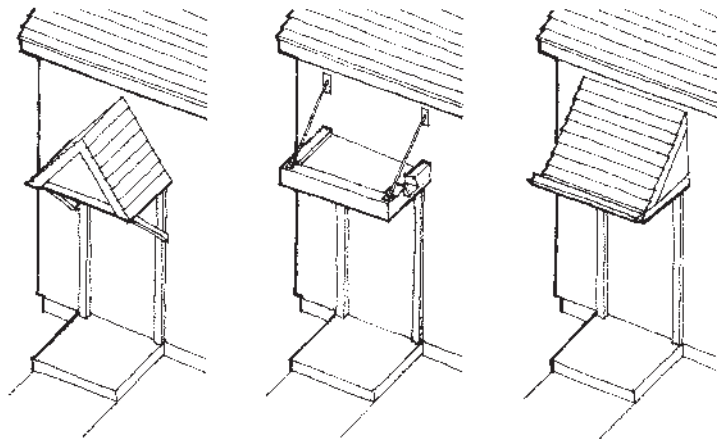

7. Roof Over Door



Drain and Weep

Drain and weep details collect and conduct away any water that may leak through the outer layer of a building cladding system. An internal drainage system acknowledges that things can go wrong in sealants, glazing compounds, gaskets, mortar joints, and metal connections – whether the problem is caused by faulty materials, inadequate workmanship, building movement, or deterioration of materials over time. This type of drainage system also releases any water that condenses inside the assembly or is introduced from interior sources. It is inexpensive insurance against the damage that can be caused by uncontrolled leakage and the expense of rebuilding a wall of flawed design. An internal drainage system is composed of spaces or channels that conduct water by gravity to weep holes or other openings that direct the water away from the building.

1. The rafter detail of a basic wood- or metal-framed greenhouse is extremely simple. Sheets of polycarbonate glazing that bear on the rafter are secured with rubber gaskets and aluminum extrusions that are held on with screws. This is not a rainscreen detail; any defect in the rubber gaskets will result in water leakage between the glazing and the rafter. Because of surface tension, water that has leaked through may cling to the rafter and run down its sides. This detail furnishes small drainage gutters in the upper surface

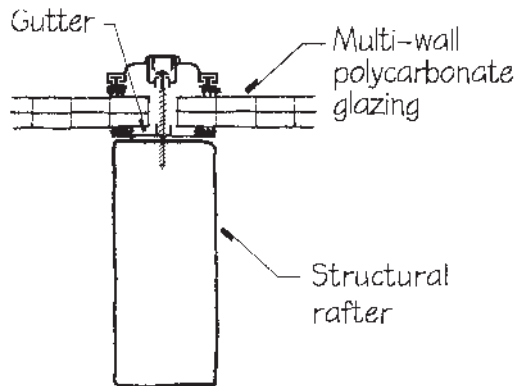

1. Greenhouse Rafter

of the gasket, located below the polycarbonate glazing. These gutters will catch this water and conduct it to the bottom of the rafter, where it weeps to the outdoors (see also **Condensate Drainage**, Chapter 4). Contemporary manufactured skylight assemblies use similar integral drainage features.

2. The outer wythe of a masonry cavity wall is expected to leak water, especially as

the mortar joints age and deteriorate. The leakage drains down the cavity until it encounters an interruption of the cavity, such as a window, door lintel, or the base of the wall. At each of these conditions, continuous flashing collects the water and drains it through weep holes that are provided at horizontal intervals of from 8 to 32 in. (203 to 813 mm). ▶

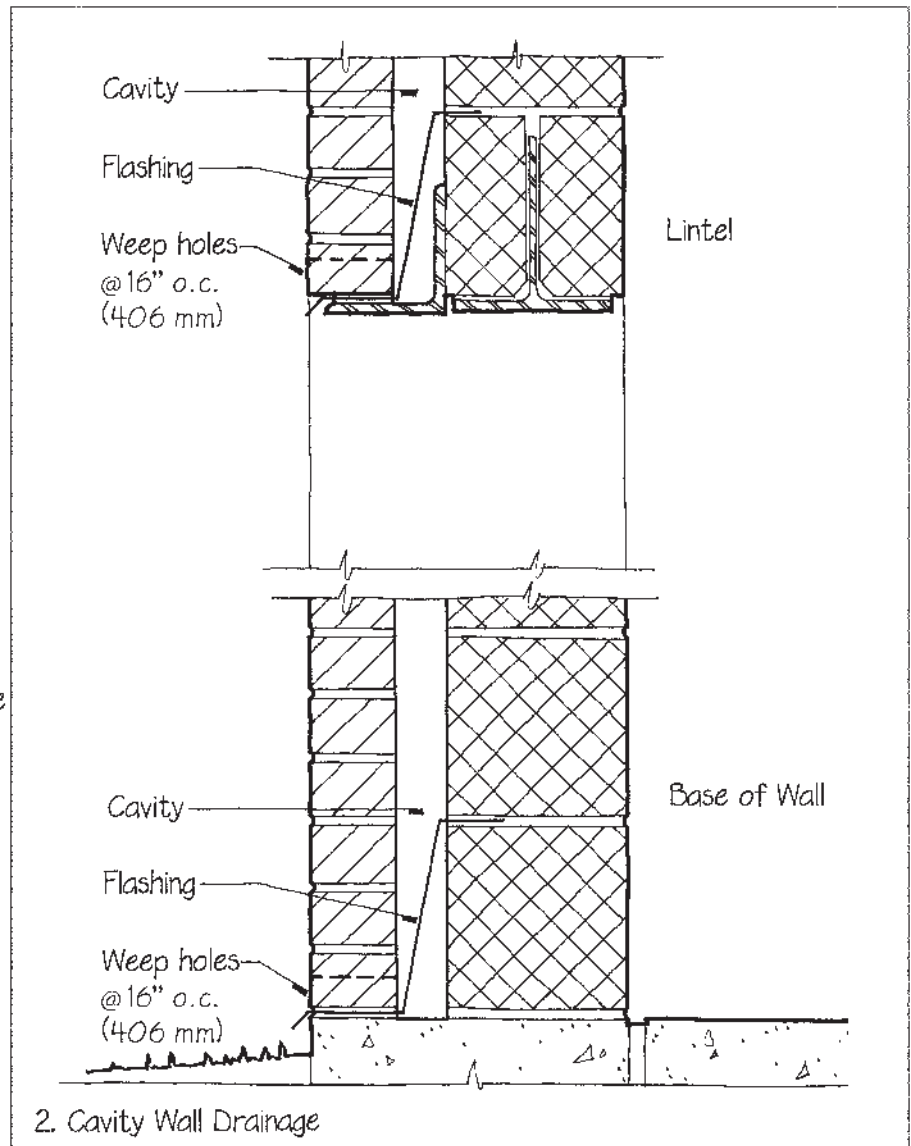

2. Cavity Wall Drainage

3. The horizontal mullion of an aluminum curtain wall acts as a gutter to accumulate leakage if the seal between the glass and the glazing gasket is imperfect. Weep holes discharge this leakage back to the outdoors. A window of average width might have three weep holes distributed across its sill. Refer to manufacturers for weep hole recommendations. Wind can drive water back through a weep hole if there is not an adequate air barrier between the weep hole and the interior of the building. This possibility can be minimized by locating the weep hole in a sheltered location unlikely to get wet and by inserting a baffle behind the weep hole. The baffle is made of a nondecaying, non-corroding open-celled material that allows water to filter out by gravity, but slows entering air currents through the opening. A typical baffle material is a nonwoven mat composed of stiff plastic filaments.

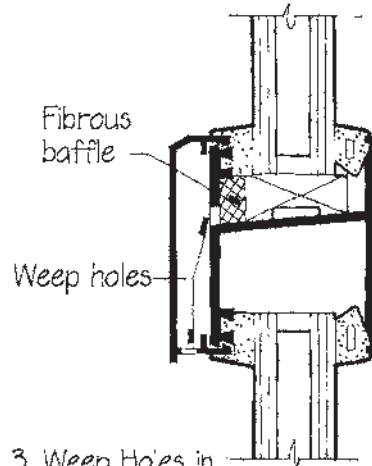

3. Weep Holes in Horizontal Mullion

4. In detailing a rainscreen panel system (see *Rainscreen Assembly and Pressure Equalization*, later in this chapter), it is important to design a three-dimensional system for draining the open joints. Especially crucial is the design of the intersections of the horizontal and vertical joints, which need to be detailed carefully for ease of assembly and for rain-tightness. Any cavity between rainscreen panels and the air barrier wall must also be drained, using a detail similar to that used in a masonry cavity wall (see detail 2).

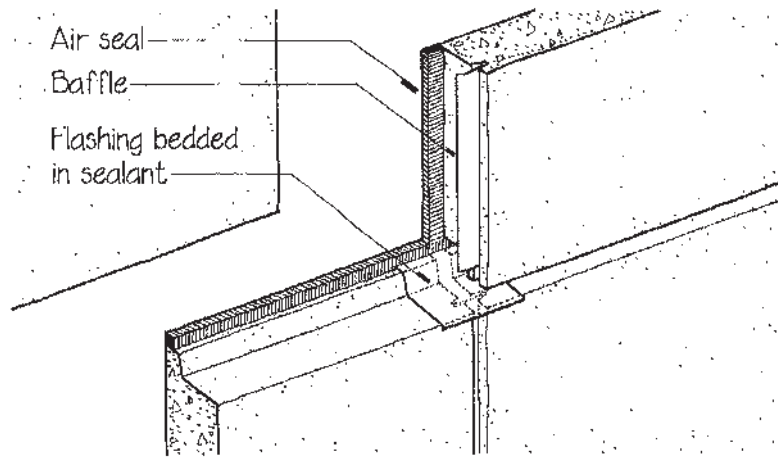

4. Rainscreen Panel Joint Intersection



Unobstructed Drainage

Water sometimes leaks into an assembly because of an inadequate or poorly maintained drainage mechanism. To achieve *unobstructed drainage*, designers must trace the path of water from where it first contacts the building to its point of discharge, to be sure that the path will be effective. The best drainage mechanisms remove water swiftly and directly. Gutterless overhangs and scuppers release water to fall by gravity, without a continuous drainage mechanism. Special attention is called for when drainage lines are concealed inside of roof or wall assemblies, because they are difficult to detect and expensive to repair.

1. Water collected in a drainage system needs to move smoothly to the discharge point by avoiding flat or circuitous paths. Paths should consist of fluid shapes, even though they may be made of sheet metal or rigid plastic. Even short distances where water is stationary can allow waterborne sediment to collect, possibly slowing or blocking the flow of water. Transitions, such as a roof drain junction in a low-slope roof, intersecting sloped roofs, and bends in the leader that carries water down through the building, are all points where turbulence is expected. Careful detailing and installation are needed to avoid obstructions and leaks at conditions like these.

2. Anticipate where obstructions may occur and include features that minimize threats to effective performance. Use rainfall intensity data from the relevant plumbing code – such as the International Plumbing Code / Storm Drainage – for the building location to calculate the volume of water to be carried by the drainage system. Include a safety factor to accommodate unusual weather, ice damming, or poor maintenance. The safety factor should double if multiple adverse factors are expected. Scale gutters, leaders, and scuppers generously, and avoid abrupt reductions in the size of the channel that carries the water. Provide accessible cleanouts at the locations where

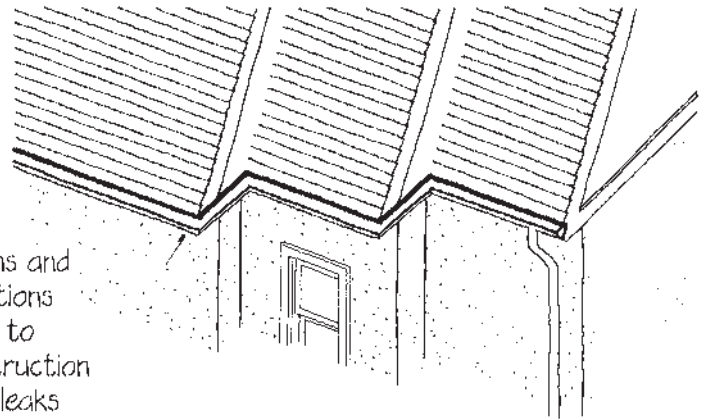

1. Irregular Gutter Configuration

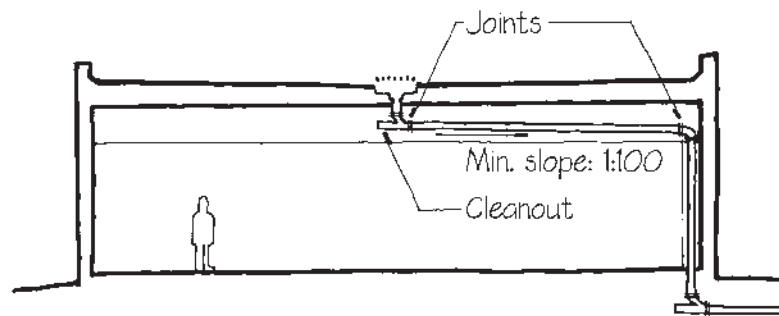

2. Concealed Roof Drain

obstruction is most likely. Where possible, include details that separate waterborne debris from the moving water. Filters or strainers at the point where water enters a roof drain, gutter, or leader are a common solution but require periodic maintenance to remove debris.

3. Joints in water drainage systems that carry precipitation, snowmelt, and condensation typically are not sealed as tightly as plumbing pipes that contain water under pressure. When drainage channels are obstructed, water may collect and cause leakage at joints. Drainage lines concealed within a wall cavity or roof assembly should be watertight to prevent leaks that are difficult to find and correct. Concealed drains

are subject to testing by code inspectors. In one such test, the drain lines are filled with water and must remain watertight for at least 15 minutes. ■



Ventilated Cold Roof

In a traditional ventilated wood-framed attic assembly, the outer surface of a roof in a snowy climate should be kept cold in winter to prevent snow from melting. Roof drainage systems often become clogged with snow and ice during cold winter weather. When meltwater runs down the roof and reaches ice-clogged gutters, drains, or eaves, pools can form that are deep enough to back up around flashings and shingles and thereby leak into the building assembly. Ventilating the underside of the roof deck with outdoor air can keep the roof cold enough so that the snow will not melt, except in above-freezing outdoor temperatures that will also melt the snow and ice in the drainage system.

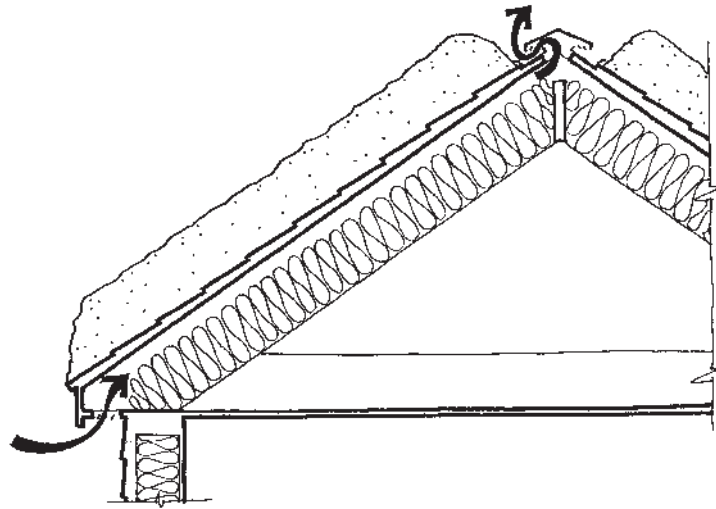

1. Ventilating Eave and Ridge

1. For cold roofs, most building codes require a prescribed minimum amount of net free ventilation area at eave and ridge in a sloping roof – commonly $\frac{1}{300}$ of the area of the space to be ventilated. A building with a ceiling area of 3,000 square feet (279 sq. m), for example, would require a total of at least 10 square feet (0.93 sq. m) of net free ventilation opening. Half this amount should be distributed along the ridge or high in the gable ends and the other half should be distributed along the eaves. These high and low ventilation openings allow convection to work efficiently to remove heat from the roof space or attic. Appropriate ventilation louvers for this purpose are available from a number of manufacturers, which list the net free ventilation area for each product.

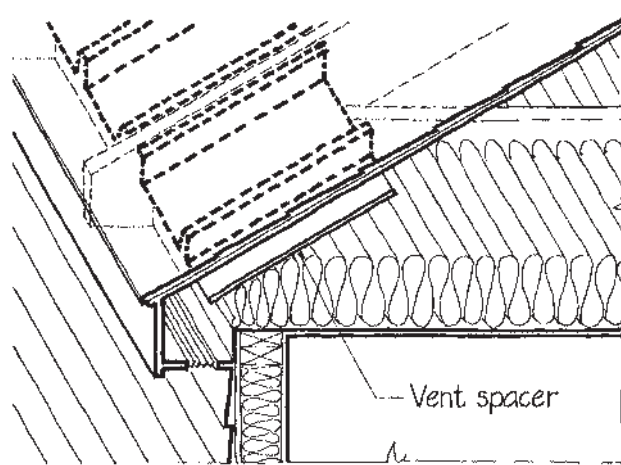

2. Vent Spacers

2. It is important to detail the cold roof so that all ventilation takes place above the thermal insulation in the roof. Most building codes require that ventilated roof assemblies have a minimum of 1 in. (25 mm) of air space between the insulation and the roof sheathing. In any situation where insulation might accidentally block the ventilating cavities beneath the roof sheathing, vent spacer channels made of

foam plastic or paper-board should be used to maintain open air passages. These channels are especially appropriate when loose fill, batt insulation, or spray-in-place foam insulation is used.

Roof ventilation also serves to carry away any water vapor that may pass through defects in the vapor retarder or through ceiling penetrations, such as light fixtures and attic hatches.

3. In cold climates, the required amount of insulation may exceed the available depth provided by ceiling joists or roof rafters. In this case, a raised-heel truss may be the best means to provide plenty of space for attic insulation and ventilation at the eave.

4. In snowy environments, some buildings with low-slope roofs are furnished with a strong horizontal lattice construction several feet above the roof that catches and holds snow, keeping the roof membrane below free of snow and ice. When the weather is warm enough to melt the snow, the water drips through the lattice and is carried away by the membrane and roof drains. The space between the roof membrane and the lattice is open to the air and tall enough for inspection and maintenance. ■

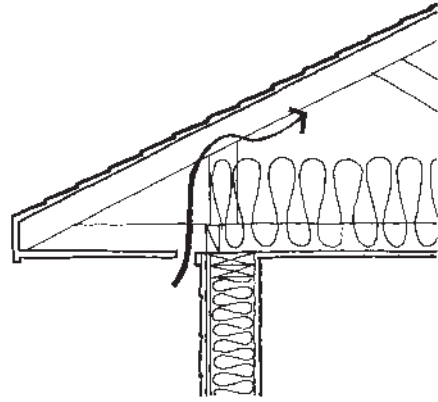

3. Raised-Heel Truss

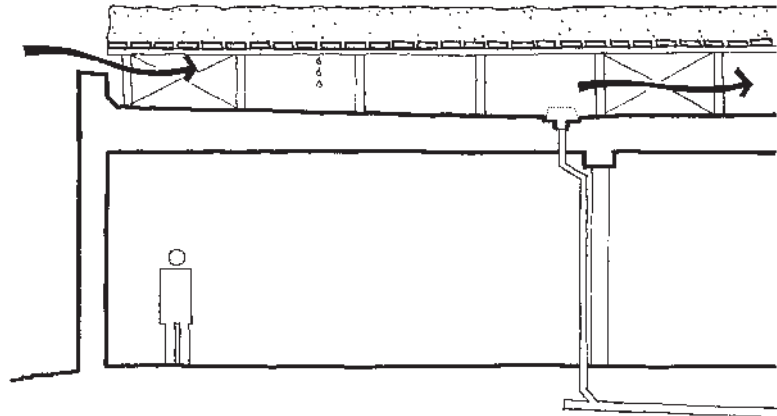

4. Snow Support Lattice



Foundation Drainage

Basements tend to leak. Water is almost always present in the surrounding soil. There are always openings in basement walls: Concrete and masonry foundation walls are full of cracks, pores, and utility line penetrations, and the joint between a basement floor slab and a foundation wall is difficult to make waterproof. Strong forces to move any water through the openings are also present, especially hydrostatic pressure. Removing water from the soil around a basement by means of foundation drainage is the surest way to keep the basement from leaking. Foundation drainage has the added benefit of reducing or eliminating the water pressure that tends to collapse the basement walls. These principles also apply to buildings without basements because groundwater can harm slabs on grade and crawl space foundation systems.

1. Slopes and swales are a first line of defense against water around a basement. They provide a simple system of sloping surfaces (see *Wash*, earlier in this chapter) of earth or paving that encourage surface water to drain away from the basement rather than toward it. Gradients of 2–10% are recommended for a distance of at least 6 ft. (1.83 m) from the house.

Roof drainage systems, including perimeter gutters or internal roof drains, collect roof water so that it can be directed away from the foundation and basement.

2. The second line of defense against water around a basement consists of perforated drain piping that is laid in porous material at the base of the basement wall. On very wet sites drain piping is sometimes laid under the floor slab as well. The porous material against the wall may be either crushed stone (of uniform particle size, for maximum porosity) and/or a thick panel or mat of synthetic material that contains large internal passages for water. When water moves through the ground toward the basement wall, it first reaches

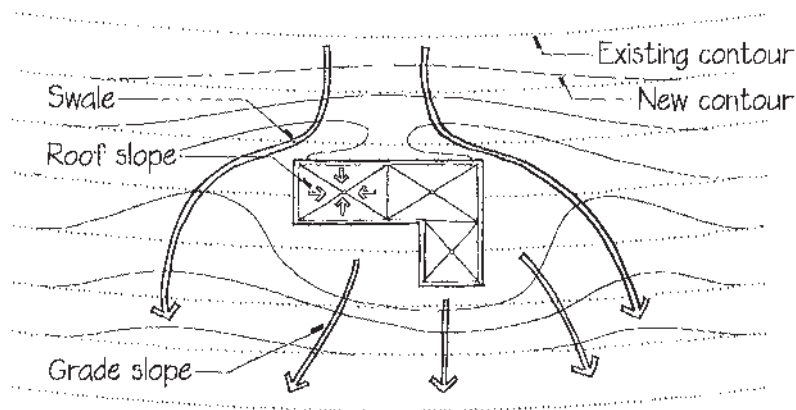

1. Plan of Surface Drainage

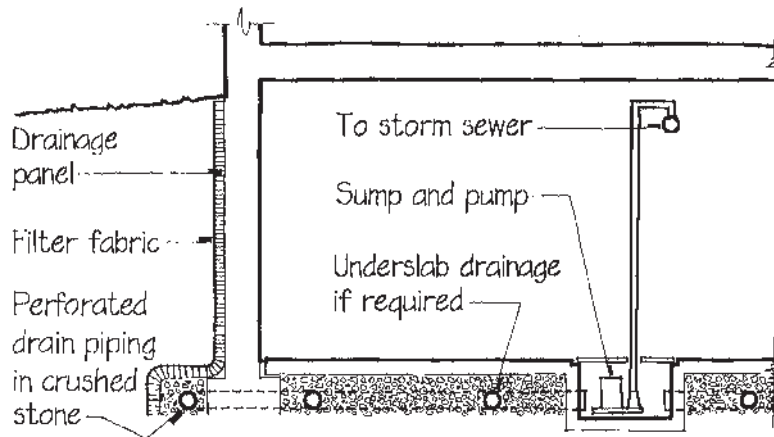

2. Foundation Drainage

the porous layer, where gravity pulls it rapidly downward.

As water accumulates at the base of the wall, it enters the open drain piping and flows by gravity either to an outlet down the slope from the building or to a sump in the basement floor, from which it is ejected by an automatic pump.

The drain piping has a line of holes or slots in it to allow water to enter. The pipe provides an unobstructed lateral passage for water through the crushed stone. Provided the pipe is placed lower than the slab of the

basement it is protecting, it makes no difference whether the holes face up, down, or sideways, except that downward-facing holes allow water to enter the pipe at a lower elevation than the other orientations.

Fine soil particles can be carried into the drainage layer by water percolating through the soil. Eventually, these particles may clog the pores of the drainage material. To prevent this, it is good practice to provide a synthetic filter fabric between the drainage material and the soil. The fabric allows water to pass freely, while straining out the soil particles. ■



Moisture Break

Most exterior building materials are not completely waterproof. When water comes in contact with permeable exterior materials, such as wood, concrete, stucco, and masonry, moisture may migrate into the material and may continue to move through the assembly, using porous materials as its path. Moisture can be prevented from moving through assemblies by using a cavity, an impermeable barrier, or both.

1. A cavity is a void that interrupts a path through one or more porous materials. Moisture reaching a cavity may evaporate or drain down into the cavity and be directed by a flashing through weeps to the exterior. Cavities are often used in vertical assemblies, such as behind stone or masonry veneers. Only metal ties bridge the cavity. These ties do not compromise the moisture break, because they are not water permeable. A reliable continuous water barrier is applied to the interior face of the cavity.

At the bottom of all cavities, an impermeable barrier may be made using a durable flashing material, such as a compatible sheet metal or flexible synthetic flashing.

At the base of the wall, continuous through-wall flashing prevents groundwater from migrating through the concrete and masonry foundation materials. This

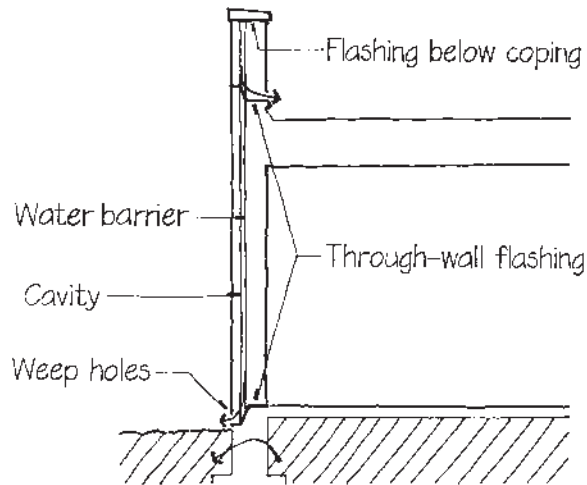

1. Moisture Breaks

flashing is installed near the elevation of finish grade, where the foundation meets the superstructure of the building.

Some of the precipitation that falls on the coping of this building may enter the assembly, either through the coping material or through its joints. Through-wall flashing is installed below the coping to isolate its moisture from the wall below. Parapet materials below the coping may also get wet, and condensation may occur in the upper portion of the wall cavity when temperatures fall below the dew point.

Through-wall flashing is also installed near the base of the parapet to prevent moisture from these sources from entering the lower portions of the wall or the roof assembly.

Through-wall flashing at the base of a cavity will also need weeps, but these are not required when through-wall flashing is not located below a cavity. Through-wall flashing enhances resistance to moisture intrusion, but it may compromise the structural integrity of the wall, so consultation with the structural engineer is recommended. ■



Capillary Break

Water can pull itself by capillary action across and even upward through a narrow crack but not a wide one. To prevent capillary entry of water, create a capillary break by enlarging the crack internally to a dimension large enough so that a drop of water cannot bridge across it, at least $\frac{1}{4}$ in. (6 mm).

1. This drawing shows a vertical edge between two exterior cladding panels that we want to place only $\frac{1}{8}$ in. (3 mm) apart. If this edge is wetted, water will be drawn into the narrow opening by capillary action. When the water reaches the capillary break, however, it will be unable to bridge it, and it will not pass farther toward the interior of the building unless pushed by wind forces.

2. In this horizontal joint between wall panels, a capillary break is created by enlarging the clear dimension of the labyrinth joint in the center of the panels.

3. Traditional detailing of the sill of a wood window shows a capillary break created by milling a groove in the under edge of the sash.

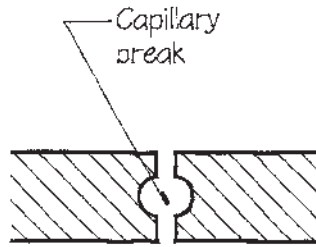

1. Vertical Panel Joint

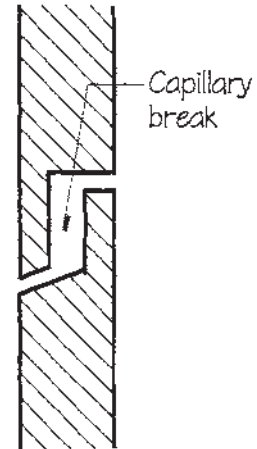

2. Horizontal Panel Joint

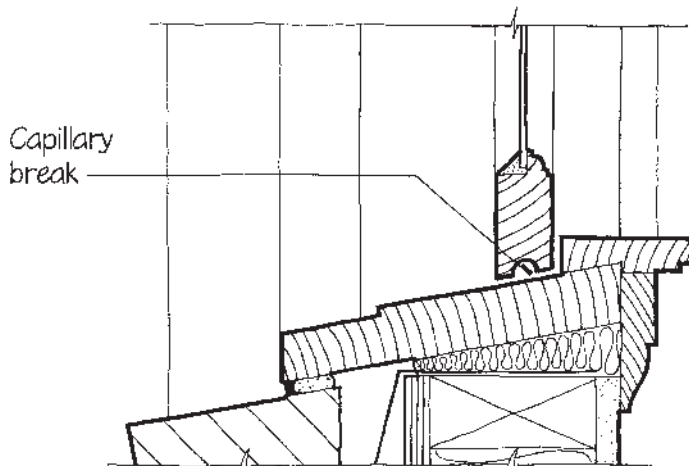

3. Wood Window Sash at Sill

4. There are two capillary breaks in this detail of an aluminum window: one between the sash and the frame, and another between the aluminum frame and the stone sill.

5. A parapet counterflashing can pull water by capillary action through the narrow

crack between itself and the upturned edge of the roofing membrane underneath. This possibility can be avoided by bending the sheet metal flashing so that it creates a capillary break.

A capillary break serves only to neutralize capillary action as a force that can

move water through a building assembly. It is a reliable and useful component of an overall strategy for making an assembly watertight, but it is not capable of resisting water penetration caused by gravity, momentum, or wind. ■

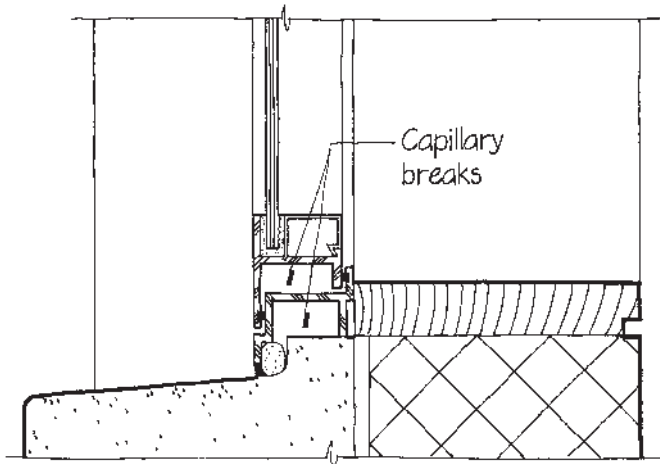

4. Metal Sash at Sill

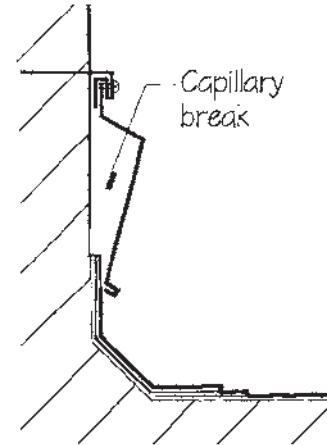

5. Counterflashing



Labyrinth

When a joint is designed so that no straight line may pass through it without striking solid material, then a raindrop or a snowflake cannot pass through the joint by its own momentum.

1. A windblown raindrop or snowflake possesses momentum that can move it through an opening in a building wall. A raindrop striking this open horizontal joint between two stone or precast concrete wall panels, for example, will splatter water through the joint toward the interior of the building, unless the joint is configured as a simple labyrinth.

2. This is a labyrinth design for the vertical joints in metal-clad foam composite panels.

3. A labyrinth can also be executed in extruded aluminum or other metal.

4. This rigid metal or plastic baffle is another approach to designing a vertical labyrinth joint. It is intended only to block water driven by momentum, so it fits loosely in the grooves. In this type of joint, the panel edges are not as fragile as in some of the other kinds of labyrinth joints, and there are no left-hand and right-hand panel edges to keep track of – both vertical edges of every panel are the same.

5. The astragal is a traditional labyrinth design that is used to keep water drops from being blown through the vertical crack between a pair of swinging doors.

A labyrinth is a very useful part of an overall strategy for preventing water penetration into a building, but it is not sufficient to prevent the passage of windblown water or snow; it must be combined with an air barrier and a pressure equalization chamber (see the following section). ■

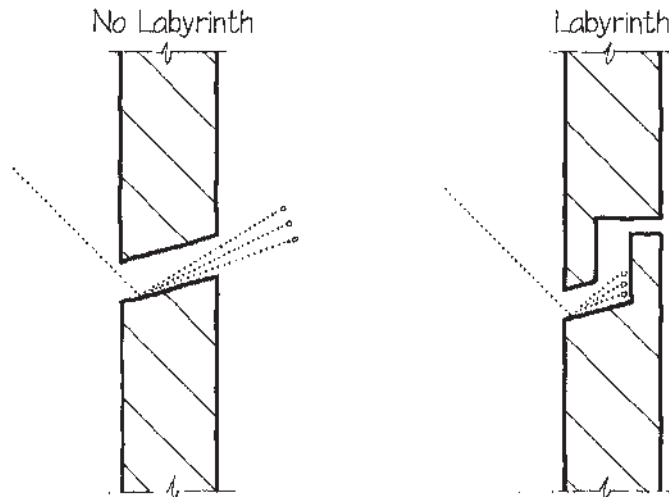

1. Horizontal Joint Between Wall Panels

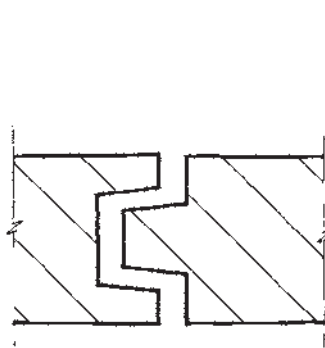

2. Vertical Labyrinth Joint Between Wall Panels

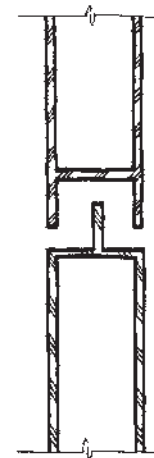

3. Aluminum Labyrinth Joint



4. Baffle in Vertical Joint



5. Astragal



Rainscreen Assembly and Pressure Equalization

A detail that blocks air currents from passing through a joint will resist water being pushed through the joint by air pressure differentials. For the same reason that you cannot blow much air into an empty soft drink bottle, wind and water cannot readily enter a joint made in this way.

1. By using a combination of *Wash, Labyrinth, Capillary Break, and Overhang and Drip*, designing a low-maintenance wall or window joint is achievable. Such a joint will resist the entry of water driven by the forces of gravity, momentum, capillary action, and surface tension. If this joint is wetted, however, and if a current of air is passing through from outside to inside, the air current can blow or pump water and vapor through the joint.

To look at it another way, the passage of the air current indicates the air pressure outside the joint is higher than the air pressure inside. This difference in pressure represents potential energy that can move water from outside to inside. Such differences in pressure exist on every building exposed to wind, which is why most water leaks in building skins occur in windy, rainy weather.

2. Air currents can force water through even circuitous joints, so an air barrier is used behind an outer rainscreen to limit the penetration of even storm-force winds. The wall panels themselves are referred to as a rainscreen, meaning that they act to screen out rainwater except at the joints. A rainscreen also deflects the kinetic force of wind-driven rain and reduces air pressure in the cavity by reducing the wind's velocity.

In projects where wind-driven precipitation is of greater concern, a pressure equalization chamber (PEC) can be created. A PEC is a container of air maintained at the same pressure as the air outside the wall by

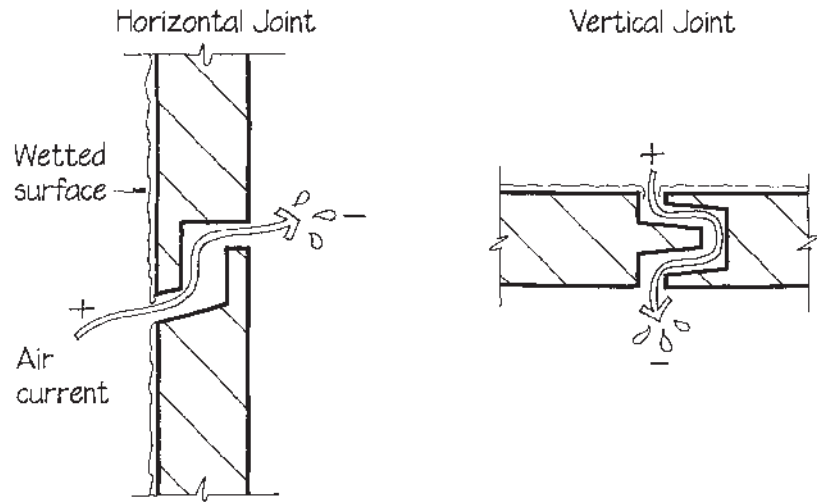

1. Water Pumped or Blown Through a Joint by Air Currents

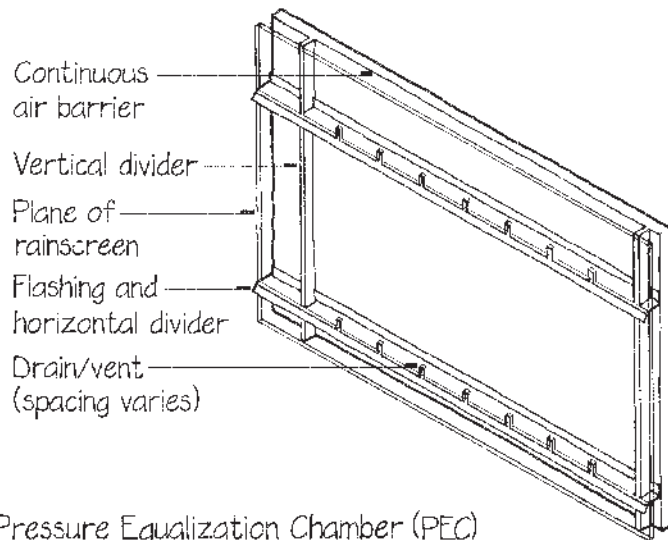

2. Pressure Equalization Chamber (PEC)

means of tiny movements of air in and out of the PEC vents.

The smaller the volume of air in the chamber, the more quickly the air pressure in the chamber equalizes the outside wind's air pressure. Quickly equalizing air pressure allows less water to be driven by wind into

the assembly. The pressure equalization strategy can be applied to small joints, and to the wall as a whole. The entire assembly of rainscreen, air barrier, and PEC is known as a rainscreen assembly, and the principle by which it works is known as the rainscreen principle. ▷

3. This is the same pair of details as in the first drawing, with the addition of a bead of sealant along the interior edge of the joint. We will assume for the moment that the sealant is perfectly airtight. Now air can pass in and out of the joint, but it can no longer pass through it. If a sudden gust of wind raises the pressure on the outside of the wall, air will be forced into the open interior of the joint by the increased external pressure. After only a very small amount of air has moved into the joint, however, the air pressure inside the joint will equal the air pressure outside, and air movement will cease. Because the two air pressures are equal, there is no energy available to pump water, so water will not penetrate past the joint. Damp-tolerant materials (see *Robust Assemblies*, Chapter 10) must be used to make the joint. The sealant joint in this detail never becomes wet; it serves only as an air barrier. The large capillary break inside the joint has now taken on a second function: It works also as a pressure equalization chamber.

4. The location of the sealant in the joint is important, especially if there is a defect in the sealant. Perhaps the sealant never adhered properly to one of the panels, or perhaps it has grown old and cracked, creating a small opening through which air or water can pass. Unless the sealant falls completely out of the joint, however, it will prevent most air from passing, and the small amount of air that does pass will not be sufficient to disrupt seriously the automatic pressure-equalizing action that prevents the pumping of water through the joint. As a rule of thumb, if the total area of leaks in the air barrier is no larger than $\frac{1}{10}$ of the total area of the openings that the air barrier protects, leakage is unlikely.

Contrast this with a defective sealant installation on the outside of the same joint

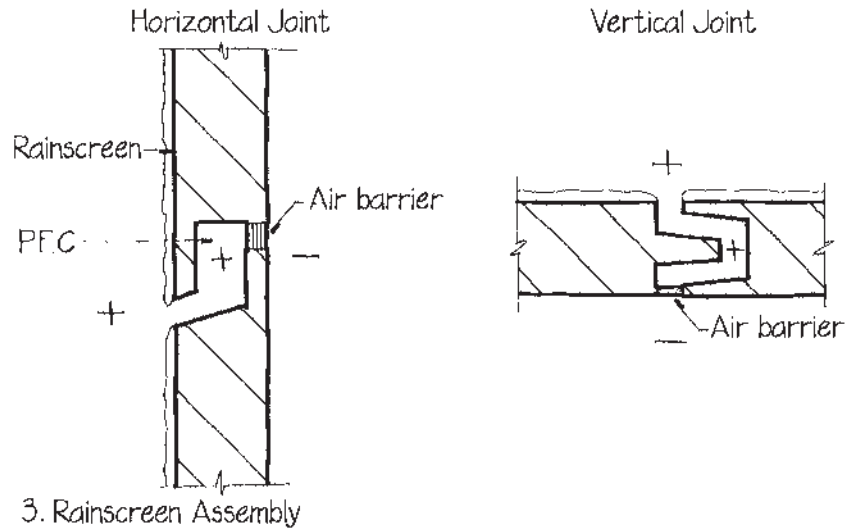

3. Rainscreen Assembly

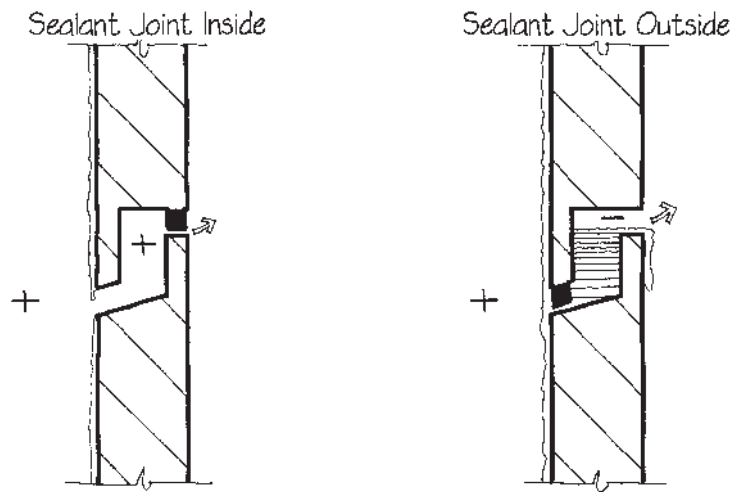

4. Effect of Defective Sealant Joints

instead of on the inside. The sealant will be bathed with water during a rainstorm, and water will be forced through the defect by even small differences in air pressure between the inside and outside. This demonstrates that the outside of a joint is not

place to install an air barrier, because in this position the air barrier only works if it is perfect. The proper location for an air barrier is on the inside of the joint, where it is always dry and where small holes, cracks, or other defects will not impair its action.

5. This is the sill of an ordinary wood window. The detail to the left incorporates all the principles we have identified so far for keeping water from penetrating: There is a wash on the sill to prevent water entry by gravity, and an overhang and drip beneath it to prevent water entry by surface tension. The L-shaped crack between the sash and the sill is a labyrinth that eliminates momentum as a force that can move water through the window unit. The groove in the bottom of the sash is a capillary break. With the addition of a reasonably airtight weatherstrip at the inside end of the crack, the groove becomes a pressure equalization chamber (PEC), and wind forces are neutralized. This detail represents a complete strategy for keeping water out – a true rainscreen detail.

The detail to the right differs from the one to the left only in the location of the weatherstrip. If the weatherstrip in this example has even a small leak, water can be forced through it during wind-driven rainstorms and can easily be pumped up onto the window stool inside.

6. To the left is a door sill that illustrates a complete rainscreen strategy for preventing water penetration. The PEC is the space under the aluminum drip strip. The air barrier is a weatherstrip on the inside face of the door (it could also be inside the crack). The rainscreen is the door itself.

The sill detail to the right shows an available type of drip strip that incorporates a synthetic rubber weatherstrip. The weatherstrip is placed just to the inside of the PEC and will remain dry and effective in this location. If it were placed, instead, at the outside edge of the drip strip, the entire detail would be unreliable.

7. The left-hand detail represents a horizontal joint between two composite metal panels of a curtain wall system. It includes a wash, a labyrinth, and an internal drip. An air barrier is provided by two synthetic rubber gaskets that are inserted into a narrow aluminum channel just behind the metal panel. This is a simple rainscreen detail. Even if the gasket does not seal perfectly, this detail will not leak.

The right-hand detail is not a rainscreen detail. It relies completely on the integrity of the sealant joint. It is much simpler and less expensive to install, but it is unreliable,

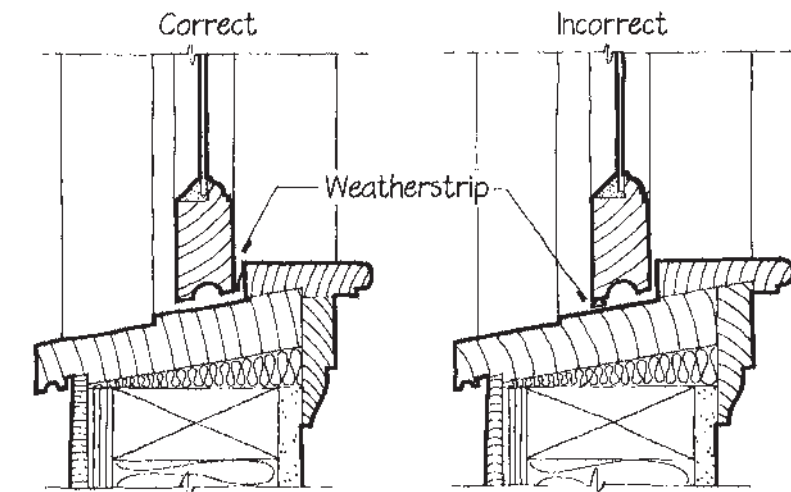

5. Wood Window Sill

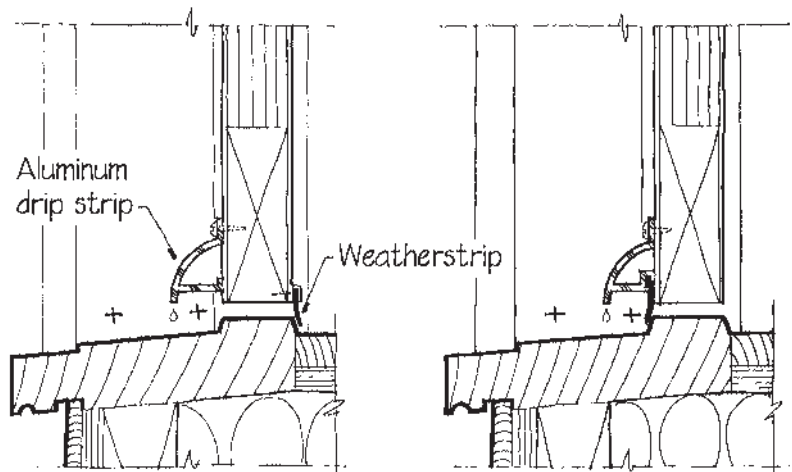

6. Rainscreen Door Sill—Two Versions

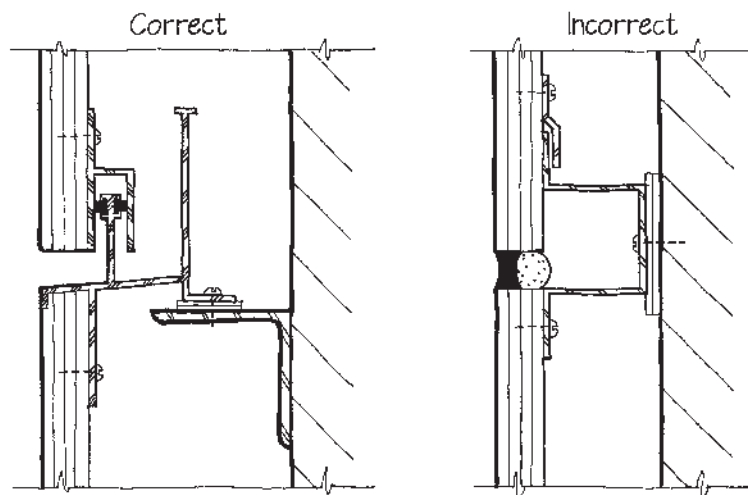

7. Horizontal Panel Joints

because any defect in the sealant will cause a water leak. An improved two-stage drained sealant joint, which creates a PEC

in the small chamber between the two sealants, is shown in *Sealant Joints and Gaskets*, later in this chapter. ▷

8. This is a typical sill detail from an aluminum-and-glass curtain wall system. It has a synthetic rubber gasket that is located on the outside of the glass. If the gasket is slightly defective, water will move past it and into the interior aluminum channel beneath the glass. The manufacturer of the wall system has anticipated this possibility, however, and has provided weep holes that will allow the leakage to drain back to the outdoors. There is also a gasket on the inside face of the glass that acts as an air barrier, preventing the water from being pumped farther toward the inside of the building.

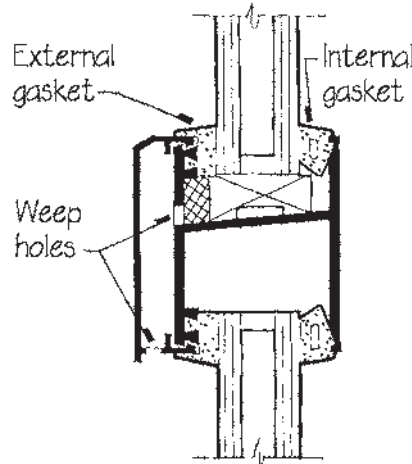

In other words, if the external gasket leaks, this detail functions as a rainscreen detail. In a detail like this, the external gasket is called a “deterrent seal,” because its role is only to deter the passage of as much water as possible, and not to act as a perfect seal against all water penetration. The internal gasket is called an “air seal” to indicate that it functions as an air barrier in a rainscreen detail.

9. The traditional masonry cavity wall is a rainscreen design. The outer wythe of masonry is the rainscreen. The cavity is the pressure equalization chamber – if it is compartmented. The sealed inner wythe of masonry is the air barrier, and the weep holes provide not only for drainage but also for the passage of air to equalize air pressure between the cavity and the outdoors.

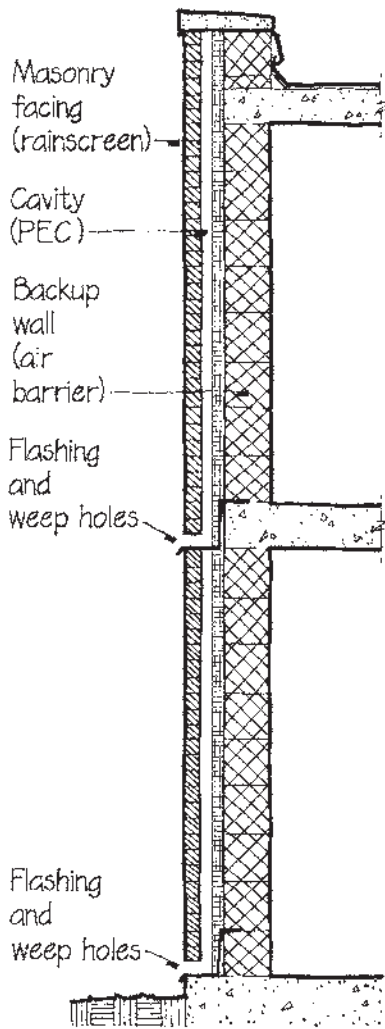

10. This drawing illustrates an adaptation of the cavity wall rainscreen design to a building faced with story-high panels of aluminum composite material (ACM). The air barrier wall is composed of steel studs, sheathing, and rigid insulation, covered with a rubberized asphalt mastic coating to make it airtight and water resistant.

In looking at these last two rainscreen designs with their large PECs, there are three important observations to keep in mind.

First, the air barrier, whether it is a backup wall, a gasket, or a bead of sealant, supports all the wind load on its portion of the face of the building. Every air barrier must be engineered to support full wind load. In a masonry cavity wall, the backup wall, not the facing, supports the wind load. In the

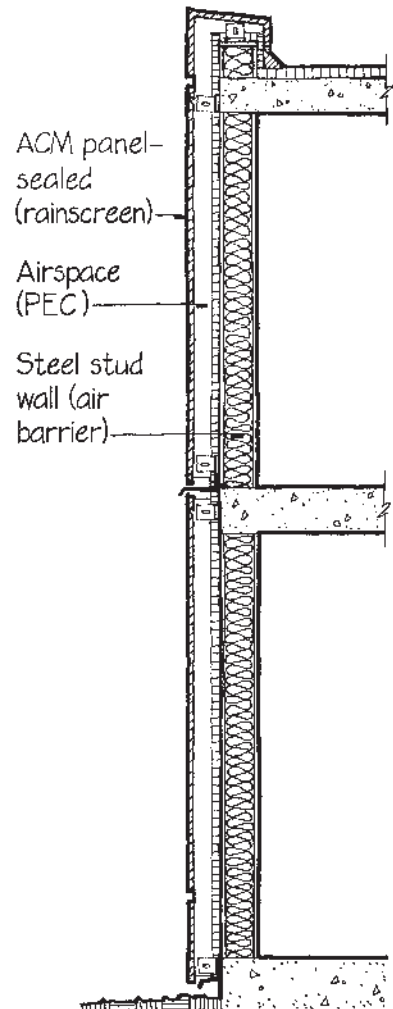

9. Masonry Cavity Wall

10. ACM Panel Rainscreen Wall

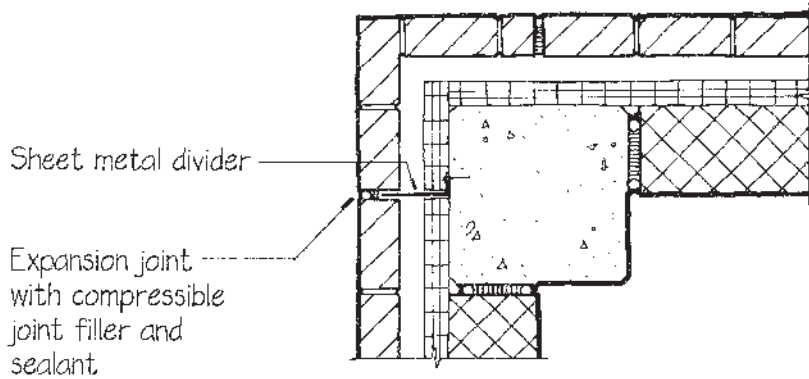

11. Vertical PEC Divider

ACM panel wall shown in drawing 10 of this section, the metal studs must be engineered to withstand the full wind load regardless of the stiffness of the panels. At a door sill, the weatherstrip must be sufficiently stiff to resist the force of wind upon it. The area of the weatherstrip is small, so the total wind force on it is similarly small, but the backup wall is large in area and must absorb a large load.

Second, wind pressure varies considerably across the face of a building. In a free-standing tall building, pressures are much higher at upper stories of the building than at lower stories, and pressures near the edges of a facade are much different from

those in the middle. Some areas of a wall are subject to suctions rather than positive pressures because of the aerodynamics of a building. Buildings in urban settings often have highly variable pressure gradients near adjoining buildings. Because of this, it is important to divide building facades into compartments. Compartments may be larger in the central portion of a facade, but they should be relatively small at building edges and parapets. Air pressure in a smaller compartment equalizes more quickly with the outside air pressure, reducing the volume of air and water entering. The largest compartments may be up to two stories high and one structural bay in width.

Drawing 11 illustrates a vertical PEC divider made of sheet metal that is economically installed into a vertical expansion joint near the corner of a building. If the chamber behind the rainscreen is not compartmented, then air pressure is reduced but not equalized. Air can rush from one part of the building facade to another within the chamber and cause localized pressure differentials that may result in water leakage. The divisions between the compartments need not be absolutely airtight, but they should be designed to choke off most airflow. The dividers can be made of masonry, sheet metal, compressible foam, or any other material appropriate to the wall construction system.

Third, every pressure equalization chamber, no matter the size, must be drained and wept to the outdoors to dispose harmlessly of any water that may enter (see *Drain and Weep*, earlier in this chapter).

The rainscreen approach cannot be applied to solid walls because a solid wall, by definition, cannot contain a pressure equalization chamber. Solid masonry or concrete exterior walls are thought of as face-sealed “barrier walls,” meaning they are so thick and so well constructed that leaking is unlikely. The barrier wall approach is far from fool-proof, however, because a single crack can allow water to enter the building. ■

An *upstand* is a dam. The principle of the upstand is that wind pressure can drive water uphill only to a height at which the hydrostatic pressure of the standing water retained by the dam is equal to the pressure exerted by the wind. An upstand is used in detailing when it is impractical to provide a reliable air barrier to prevent water from being driven through a horizontal crack by air pressure differentials. This can happen in situations where installation access to the proper location for an air barrier is blocked by a spandrel beam or a column. It can happen at the sill of a door or a window as a gasket or weatherstrip ages, wears, and begins to leak large volumes of air. The upstand reduces pressure that might force water through an imperfect weatherstrip. In any of these cases, a simple upstand can serve to prevent wind pressure from pushing water through a horizontal joint, even if the joint is totally unsealed against air leakage.

The required height of an upstand is determined by the maximum expected wind pressure. To find the wind pressure, find the design wind speed for the building location in the appropriate building code. (Note: Building and site configurations may create local wind speeds that exceed the general wind loads stated in building codes.) Then determine the necessary height of the upstand according to Table 1-1, interpolating as necessary.

1. A manufacturer of sliding glass doors recognizes that if the interior weatherstrip becomes sufficiently worn with years of

TABLE 1-1: Minimum Heights of Upstands

Approximate Wind Speed	Wind Pressure	Upstand Height
45 mph (70 km/h)	5 psf (240 Pa)	1" (25 mm)
60 mph (100 km/h)	10 psf (480 Pa)	2" (51 mm)
90 mph (145 km/h)	20 psf (960 Pa)	4" (102 mm)
110 mph (175 km/h)	30 psf (1,440 Pa)	6" (152 mm)
125 mph (200 km/h)	40 psf (1,920 Pa)	8" (203 mm)
140 mph (225 km/h)	50 psf (2,400 Pa)	10" (254 mm)

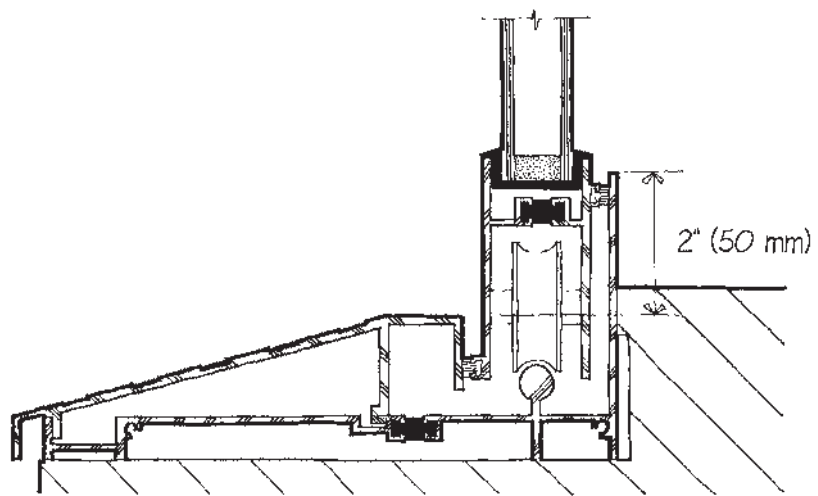

1. Sill of Sliding Glass Door

use, the rainscreen action of the sill detail may become inoperative. A 2 in. (51 mm) upstand at the interior side of the door offers a degree of backup protection by preventing leakage up to a maximum wind pressure

of 10 psf (480 Pa), equivalent to a 60-mph wind (100 km/h). A taller upstand would offer even more protection against leakage, but this advantage must be weighed against the increased tripping hazard of a taller sill.

2. This horizontal joint between metal curtain wall panels has a 3 in. (75 mm) upstand, giving protection against water penetration at wind pressures as high as 15 psf (720 Pa), even if the gasket has been inadvertently omitted during installation.

3. To prevent water being pumped back through a weep hole by wind pressure, the hole can be drained through a vertical weep tube that exits the wall a distance below the point that is being drained. If there is a vertical distance of 10 in. (254 mm) between the inlet and outlet of a weep tube, for example, it would take a wind of approximately 140 mph (225 km/h) to pump water up and into the building through the tube. This is the upstand principle applied in a different way, using the same table to equate heights of water to pressures of air. The tube diameter must be at least 3/8 in. (9.5 mm) for good drainage; this is also large enough to prevent capillary entry of water.

When detailing an upstand, its ends must be dammed carefully at vertical joints, or the water will simply drain out of the ends to become unwanted leakage. In aluminum cladding details, end dams are often plugs molded of synthetic rubber. ■

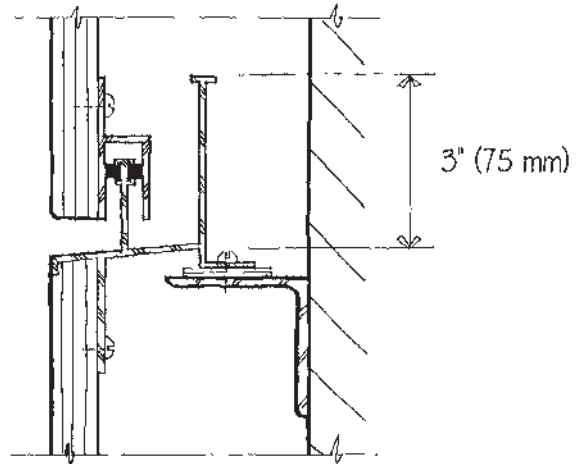

2. Horizontal Joint Between Curtain Wall Panels

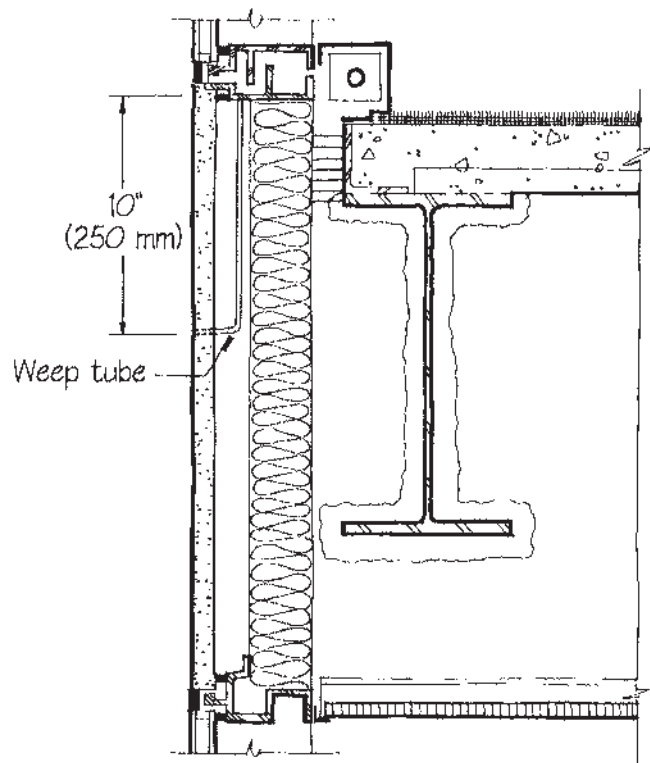

3. Weep Tube in Curtain Wall



Sealant Joints and Gaskets

Sealants and gaskets are elastic materials placed in a joint to block the passage of air and/or water, while allowing for relative movement between the two sides of the joint. A gasket is a strip of elastomeric rubber that is compressed into the joint. Most sealants are mastic materials injected into the joint and then cure to a rubberlike state. A gasket seals a surface by compressing tightly against it. A sealant seals by adhering tightly to the surface.

1. The width and depth of a sealant joint must never be left to chance; they should be determined in accordance with the procedure shown in *Expansion Joint* (see Chapter 6). The plastic-foam backer rod is a critical part of every sealant joint: It limits the depth of the sealant to the predetermined dimension, provides a firm surface against which to tool the sealant, and imparts to the sealant bead the 1:2 hourglass shape that optimizes the strength and elasticity of the sealant. The backer rod should be at least 20% larger than the maximum joint width.

2. If the sealant joint is too narrow, normal amounts of movement between the adjoining components can overstretch the sealant and tear it. This can also happen if the sealant joint is too shallow in proportion to its width.

3. If the sealant bead is too deep, stresses in the bead will be excessive, and tearing is likely.

4. Tooling forces the sealant material to fill the joint, assume the desired profile, and adhere to the adjoining components.

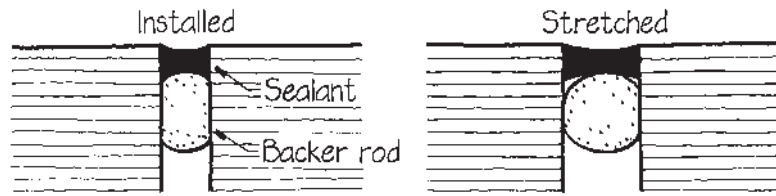

1. Correctly Proportioned Sealant Joint

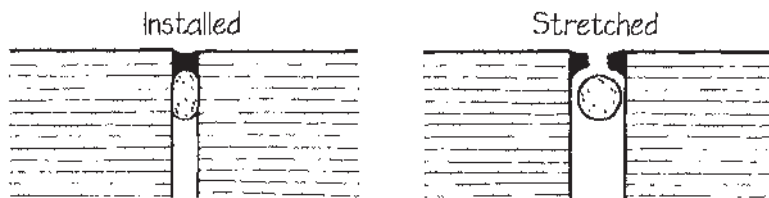

2. Incorrect: Joint Too Narrow

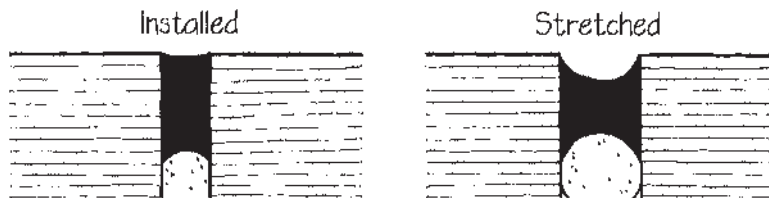

3. Incorrect: Sealant Bead Too Deep

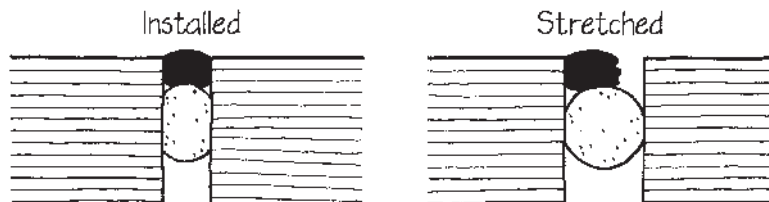

4. Incorrect: Sealant Bead Untooled

5 and 6. In a three-sided sealant joint, bond-breaker tape should be applied against the back of the joint to allow for full extension of the sealant bead when the joint opens.

7. If a sealant joint is too narrow, the sealant may become overcompressed, squeezing it out of the joint and tearing it.

8. Sealant should be applied at an air temperature that is neither too hot nor too cold. If application at very hot or very cold temperatures is anticipated, the initial joint width should be adjusted to compensate for the seasonal overstressing that might otherwise occur. ▷

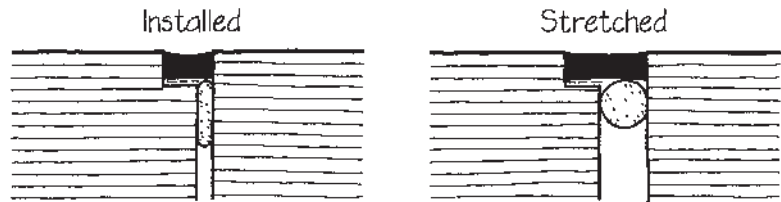

5. Correct: Bond Breaker in Three-Sided Joint

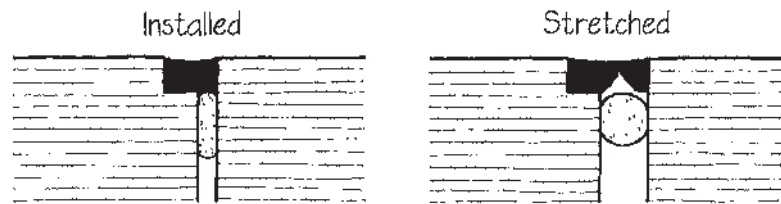

6. Incorrect: No Bond Breaker

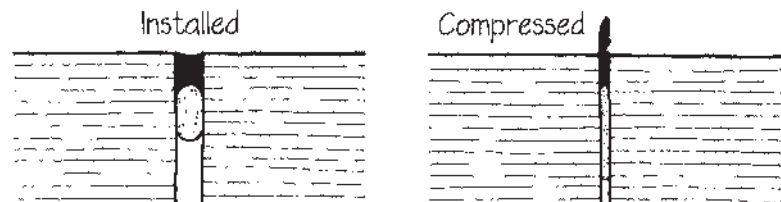

7. Incorrect: Joint Too Narrow

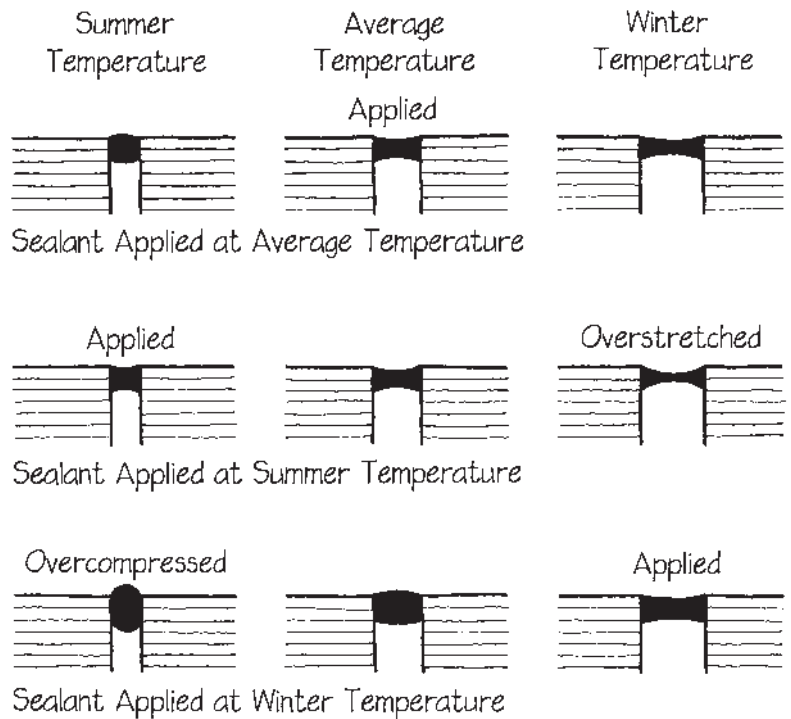

8. Sealant Application and Temperature

9. A sealant lap joint may be dimensioned using the same procedures as for a normal butt joint, such as those illustrated previously in this section.

10. Even if perfectly installed, sealant joints are likely to fail as the material ages and becomes less elastic. Added protection and durability can be provided by a two-stage drained sealant joint. This consists of the careful installation of backer rod and sealant within the joint and recessed behind the outer sealant joint to produce a small cavity. Two-stage joints require a minimum joint width of $\frac{3}{4}$ in. (19 mm) for sufficient access by the installer. Vertical two-stage joints must be detailed to drain any water at the bottom of the joints. The cavity between sealants can also be pressure-equalized if the inner seal is airtight.

11. There are many types of glazing details that include wet (gunnable) sealants. In general, these incorporate synthetic rubber spacers that regulate the depth and thickness of the sealant, according to the principles laid out earlier. In the detail to the left in the drawing, the glass is set on synthetic rubber blocks and centered in the metal frame with the aid of compressible spacer strips that also serve as backer rods. This detail minimizes the number of different components needed to install the glass by eliminating any gaskets. The detail to the right uses a preformed synthetic rubber gasket on the interior side for easy installation and a neat appearance. The outside is sealed with a gunnable sealant for maximum security against leakage.

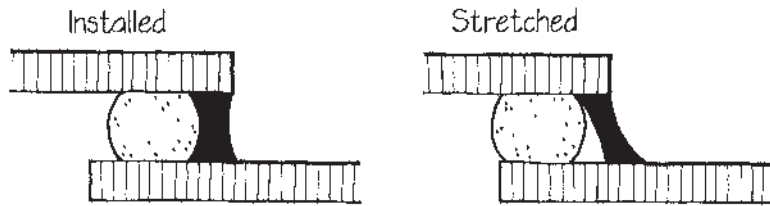

9. Sealant Lap Joint

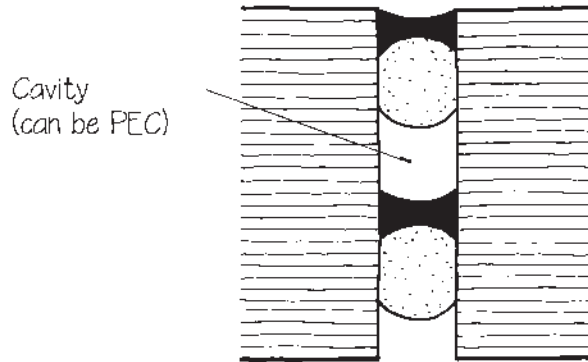

10. Two-Stage Sealant Joint

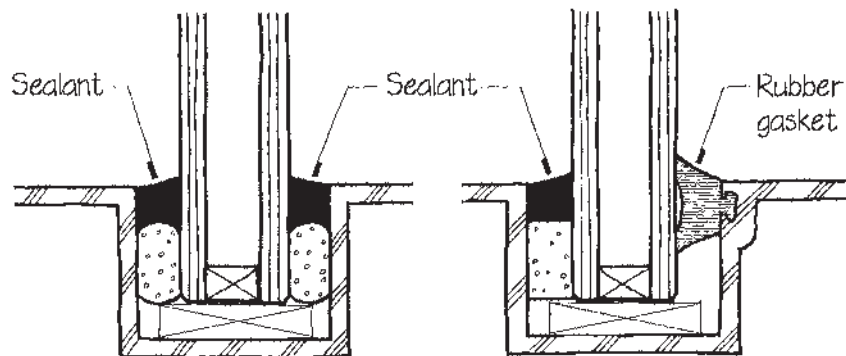

11. Glazing Details Using Wet Sealants

12. This is an example of a preformed synthetic rubber gasket used to close a movement joint in a high-traffic horizontal surface, such as a roadway or a parking garage. The gasket is slightly wider than the joint and must be compressed during installation.

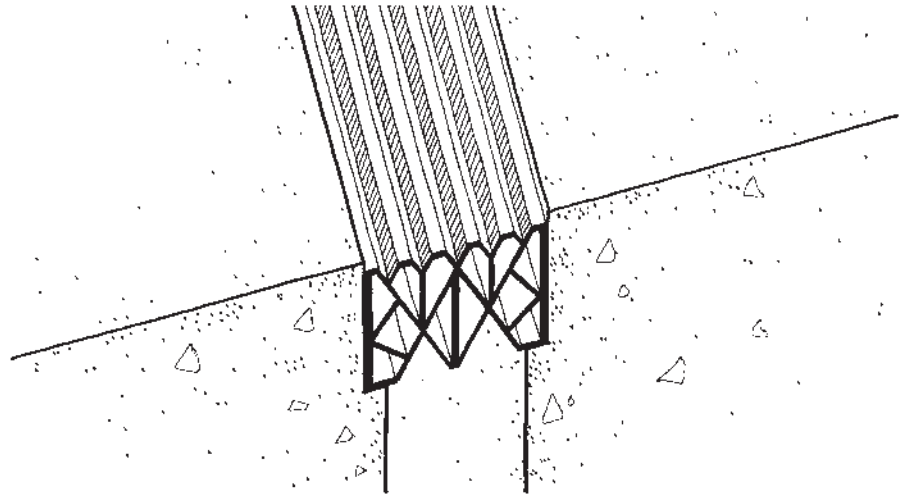

12. Synthetic Rubber Compression Seal

13. Preformed gaskets are widely used to seal between window glass and metal framing. In this example, a closed-cell sponge gasket is inserted first; then the glass is inserted. Finally, a dense gasket in a roll-in wedge profile is forced between the inside face of the glass and the frame, compressing the sponge gasket and holding the entire assembly together. For additional security against water penetration, a bead of gunnable sealant is sometimes placed over the outside gasket. This is called a cap sealant. Gaskets are typically miter-cut to fit snugly at corners.

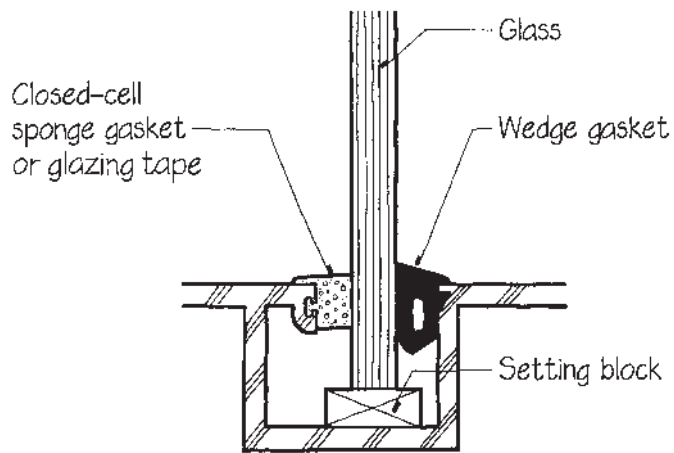

13. Preformed Gasket Glazing

14. There are many types of synthetic rubber lockstrip gaskets that are useful in glazing applications. This example incorporates a pine tree spline that is inserted into a slot in a concrete sill or jamb. The glass is installed in the gasket, and then the synthetic rubber lockstrip is inserted with a special tool, to make the gasket rigid and lock the glass in place. Lockstrip gaskets are simple and secure but have been found to be vulnerable to water leakage, perhaps because they do not exert sustained pressure on the lip of the gasket against the glass. This vulnerability does not limit their use in interior or sheltered settings. ▷

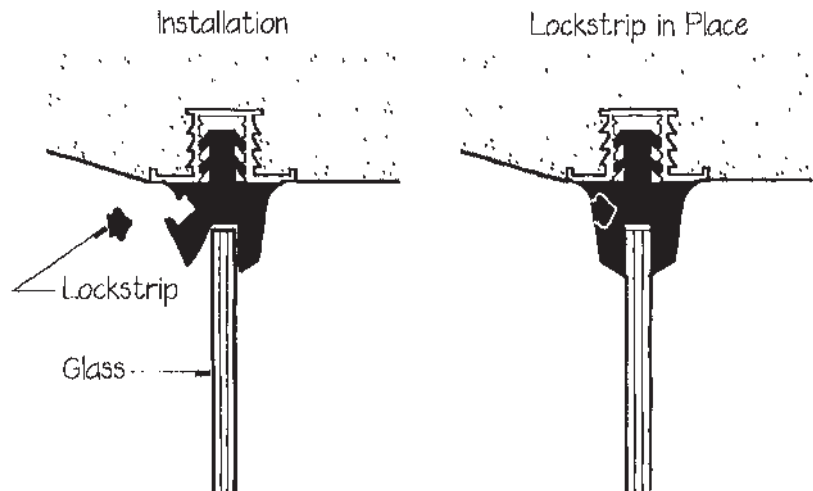

14. Lockstrip Gasket Glazing

15. Preformed solid tape sealants are made to be compressed between components of nonworking joints. The tape is thick and very sticky. The semirigid shim rod in the center of the tape controls the thickness of the joint and limits the tendency of the surrounding mastic to squeeze out.

16. The waterstop is a preformed synthetic rubber gasket used to seal pour joints and movement joints in concrete foundation walls. The example shown here features a center tube that allows the waterstop to stretch or compress considerably in response to movement in the concrete walls. Many other shapes of synthetic rubber waterstops are also manufactured, along with alternative designs made of rigid plastic, metal, mastic, and even bentonite clay, which expands and seals when wetted.

Glazing and cladding details are usually developed by manufacturers of glazing and cladding systems, rather than by detailers in architectural offices. However, it is important for designers and detailers to have a good grasp of detailing principles so that they are able to assess manufacturers' systems and installed work in the field.

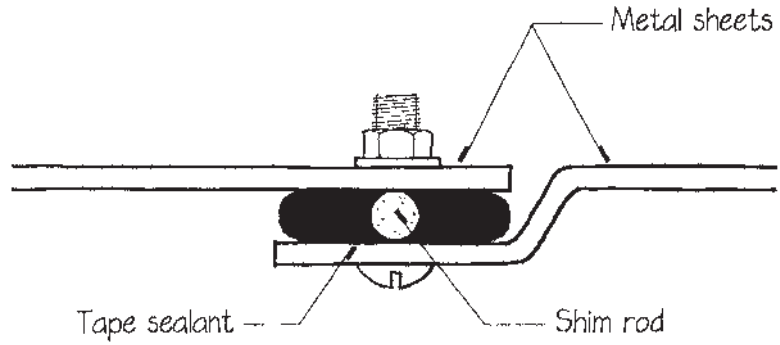

15. Preformed Solid Tape Sealant

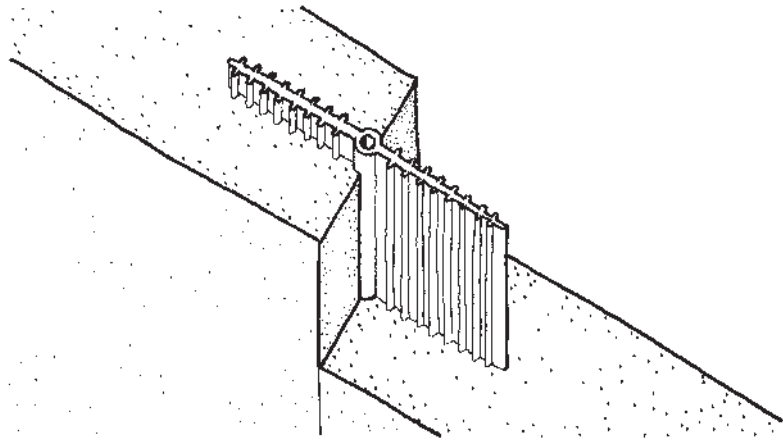

16. Waterstop

PROPORTIONING SEALANT JOINTS

Sealant joints should be provided at frequent enough intervals in a surface so that the expected overall movement in the surface is divided into an acceptably small amount of movement in each joint. Usually, sealant joint spacing is determined by the desired sizes of the panels or sheet materials that make up a wall.

Generally, a sealant joint should not be narrower than $\frac{1}{4}$ in. (6 mm). A joint narrower

than this is difficult to make and has little ability to absorb movement. Joints can be as wide as 1–2 in. (25–51 mm), depending on the ability of the sealant not to sag out of the joint before it has cured. The depth of sealant in a joint should be equal to half the width of the joint, but not less than $\frac{1}{4}$ in. (6 mm) or more than $\frac{1}{2}$ in. (13 mm). Thus, a $\frac{1}{4}$ -in.-wide joint should be $\frac{1}{4}$ in. deep (6×6 mm), a $\frac{3}{4}$ -in.-wide joint should be $\frac{3}{8}$ in. deep (19×9 mm), and a $1\frac{1}{4}$ -in.-wide joint should be $\frac{1}{2}$ in. deep (32×13 mm).

To determine the required width for a sealant joint in a particular location in a building, many factors must be considered. The spacing between movement joints, the particular materials used, and the climate at the building location are some of these factors.

A complete discussion of this topic, including example calculations of sealant joints, follows in the section “Determining Widths of Sealant Joints.”

Determining Widths of Sealant Joints

Calculations of expansion joint intervals and sealant joint widths are interdependent. The width of a sealant joint should be determined by the designer of the building, the detailer, the specifications writer, the suppliers of the components or materials on either side of the joint, and the structural engineer. These collaborators work together using all available information on temperature extremes at the building site, the time of year when the sealant will be installed, the properties of the materials on either side of the joint, the properties of the sealant itself, and the structural characteristics of the frame and skin of the building. For preliminary purposes, the following equation may be used to determine the width of any sealant joint:

$$W = \frac{100}{X} (\epsilon L \Delta T + M_o) + t$$

where

W = required width of sealant joint

X = % plus or minus movement capability of sealant, expressed as a whole number

ϵ = coefficient of expansion of skin material

L = length of building skin between joints

ΔT = annual range between extreme high and low temperatures. If specific temperature data is lacking, assume that ΔT is 130°F (54°C)

M_o = anticipated movement due to such nonthermal factors as structural deflections, creep, or moisture expansion and contraction

t = construction tolerance

This formula may be used with either conventional or SI units. Following are three examples of its use.

TABLE 1-2: Coefficients of Linear Thermal Expansion of Common Building Materials (verify properties of specific materials used)

		in./in./°F	mm/mm/°C
Wood (seasoned)			
Douglas fir	parallel to grain	0.000021	0.000038
	perpendicular to grain	0.000320	0.000580
Pine	parallel to grain	0.000030	0.000054
	perpendicular to grain	0.000190	0.000340
Oak	parallel to grain	0.000027	0.000049
	perpendicular to grain	0.000300	0.000540
Maple	parallel to grain	0.000036	0.000065
	perpendicular to grain	0.000270	0.000486
Masonry and Concrete			
Limestone		0.000044	0.000079
Granite		0.000047	0.000085
Marble		0.000073	0.000131
Brick and terra-cotta		0.000036	0.000065
Concrete masonry units, normal aggregate		0.000052	0.000094
Concrete masonry units, lightweight aggregate		0.000043	0.000077
Concrete		0.000055	0.000099
Autoclaved aerated concrete		0.000045	0.000081
Metals			
Steel		0.000065	0.000117
Stainless steel, Type 304		0.000099	0.000173
Aluminum		0.000128	0.000231
Copper		0.000093	0.000168
Lead		0.000151	0.000272
Tin		0.000161	0.000290
Titanium		0.000050	0.000090
Zinc		0.000172	0.000310
Finish Materials			
Gypsum board		0.000090	0.000162
Gypsum plaster, sand		0.000070	0.000126
Fiber cement panel		0.000076	0.000142
Glass		0.000050	0.000090
Acrylic glazing sheet		0.000410	0.000742
Polycarbonate glazing sheet		0.000440	0.000796
Polyethylene		0.000850	0.001530
Polyvinyl chloride		0.000400	0.000720
Polyester, glass fiber reinforced		0.000140	0.000250

Sealant Joint Width Calculations

Example 1 Calculate the required width of a horizontal sealant joint for an all-aluminum curtain wall panel, dark gray in color, that is 6 ft. 8 in. or 80 in. (2032 mm) high. The temperature ranges annually between -40° and $+100^{\circ}\text{F}$ (-40° and $+38^{\circ}\text{C}$). The building is framed with steel. A sealant with a movement capability of 125% is recommended by the wall panel manufacturer.

The annual range of air temperature is 100° to $-40^{\circ}\text{F} = 140^{\circ}\text{F}$ (78°C), but the sun will heat the dark-colored panel to well above the air temperature. As an estimate, we will add 40°F (22°C) to the temperature to account for this phenomenon, making a total temperature range of up to 180°F (100°C).

The structural engineer estimates that deflections of the spandrel beams and columns under live and wind loadings can total as much as 0.04 in. (1 mm) per panel.

The construction tolerance, the accuracy of the aluminum panels as installed on the building, is estimated by the curtain wall contractor to be $\pm\frac{1}{8}$ in. (3.2 mm). From Table 1-2, we determine that the coefficient of thermal expansion of aluminum is 0.0000128 in./in./ $^{\circ}\text{F}$.

Starting with the given equation:

$$W = \frac{100}{X}(\varepsilon L\Delta T + M_o) + t$$

and substituting,

$$W = \frac{100}{25}[(0.0000128 \text{ in./in./}^{\circ}\text{F})(80 \text{ in.}) \\ (180^{\circ}\text{F}) + 0.04 \text{ in.}] + 0.125 \text{ in.}$$

we have $W = 1.02$ in.; use a 1-in.-wide sealant joint or $1\frac{1}{8}$ in., if we wish to be conservative. The depth should be $\frac{1}{2}$ in.

This example may be worked in SI (metric) units using the same formula and procedure, so long as all the units of length are consistent and the temperature is converted from Fahrenheit to Celsius.

$$W = \frac{100}{25}[(0.0000231 \text{ mm/mm/}^{\circ}\text{C}) \\ (2032 \text{ mm})(100^{\circ}\text{C}) + 1 \text{ mm}] \\ + 3.2 \text{ mm}$$

we have $W = 25.98$ mm; use a 26 mm wide sealant joint. The depth should be 13 mm.

Example 2 Calculate the required width of a sealant joint between white granite wall panels that are 4 ft. 7 in. or 55 in. (1397 mm) in maximum dimension. The annual range of air temperature is from -10° to 110°F (-23° to 43°C). The building structure will be of reinforced concrete, and the structural engineer estimates that creep in the frame will eventually reach about 0.03 in. (0.76 mm) per panel, but that structural deflections will be insignificant. The sealant will have a movement capability of $\pm 25\%$. The supplier and installer of the granite panels expect to work to an accuracy of $\pm\frac{3}{16}$ in. (4.76 mm).

From Table 1-2 in Example 1, we find a coefficient of thermal expansion for granite of 0.0000047 in./in./ $^{\circ}\text{F}$. Starting with the given equation:

$$W = \frac{100}{X}(\varepsilon L\Delta T + M_o) + t$$

and substituting,

$$W = \frac{100}{25}[(0.0000047 \text{ in./in./}^{\circ}\text{F})(55 \text{ in.}) \\ (120^{\circ}\text{F}) + 0.03 \text{ in.}] + \frac{3}{16} \text{ in.}$$

we have $W = 0.43$ in.; use a $\frac{1}{2}$ -in. joint. A depth of $\frac{1}{4}$ in. is suitable.

Working in SI (metric) units:

$$W = \frac{100}{25}[(0.0000085 \text{ mm/mm/}^{\circ}\text{C}) \\ (1397 \text{ mm})(66^{\circ}\text{C}) + 0.76 \text{ mm}] \\ + 4.76 \text{ mm}$$

we have $W = 10.93$ mm; use a 11-mm joint. A depth of 6 mm is suitable.

Example 3 Calculate the required width of a vertical sealant joint in a brick wall with a joint spacing of 21 ft. 4 in. or 256 in. (6.5 m or 6500 mm). The air temperature range is up to 108°F (60°C). The contractor would like to use a sealant that has a movement capability of $\pm 12.5\%$. According to *Technical Note No. 18* of the Brick Industry Association, brickwork will expand over time by about $\frac{2}{100}$ of 1% due to moisture absorption. A construction tolerance of $\pm\frac{1}{4}$ in. (6 mm) is expected.

According to Table 1-2, the coefficient of thermal expansion of brick masonry is about 0.0000036 in./in./ $^{\circ}\text{F}$ (0.0000065 mm/mm/ $^{\circ}\text{C}$). Starting with the given equation:

$$W = \frac{100}{X}(\varepsilon L\Delta T + M_o) + t$$

and substituting,

$$W = \frac{100}{12.5}[(0.0000036 \text{ in./in./}^{\circ}\text{F}) \\ (256 \text{ in.})(108^{\circ}\text{F}) + (256 \text{ in.}) \\ (0.0002)] + \frac{1}{4} \text{ in.}$$

we have $W = 1.45$ in.

Working in SI (metric) units:

$$W = \frac{100}{12.5}[(0.0000065 \text{ mm/mm/}^{\circ}\text{C}) \\ (6500 \text{ mm})(60^{\circ}\text{C}) + (6500 \text{ mm}) \\ (0.0002)] + 6 \text{ mm}$$

we have $W = 36.7$ mm

This is very wide, nearly $1\frac{1}{2}$ in. – which would make sealant installation difficult. If a sealant with a $\pm 25\%$ movement capability was used instead, the joint would only need to be $\frac{7}{8}$ in. (22 mm) wide, which could be rounded up to 1 in. (25 mm). If a narrower joint is desired, then another sealant with even greater movement capability could be selected. ■

