

1

PLUMBING

If you are like most homeowners, the maze of hot and cold supply pipes and waste pipes in your basement resembles nothing more meaningful than a plate of spaghetti. This chapter will show you that, in fact, your house contains three separate systems of pipes, all making perfect sense.

Understanding their purpose and how each one works will enable you to decide which projects are in the realm of a homeowner, and which ones require a plumber. If you're planning to build a new home or do major remodeling, this chapter will also help you to visualize the plumbing requirements, and how they'll fit into your space.

A visit to the plumbing aisle of your local home center will show you that do-it-yourself plumbing repair has never been easier. There you will find kits, including illustrated instructions, for just about every common repair project.

Plumbing is not dangerous, unless you're dealing with gas pipes. In fact, call a licensed professional if your repair or installation involves any change to existing gas piping. But plumbing mistakes can be damaging to the finishes and contents of your home, just by getting them wet. The force and weight of water are also something to be reckoned with, if many gallons flow where they should not. Before starting a project involving the supply system, locate the shut-off valve for the fixture you're working on. If you can't find one, shut off the main valve where the supply enters the house.

1

PLUMBING

The Supply System

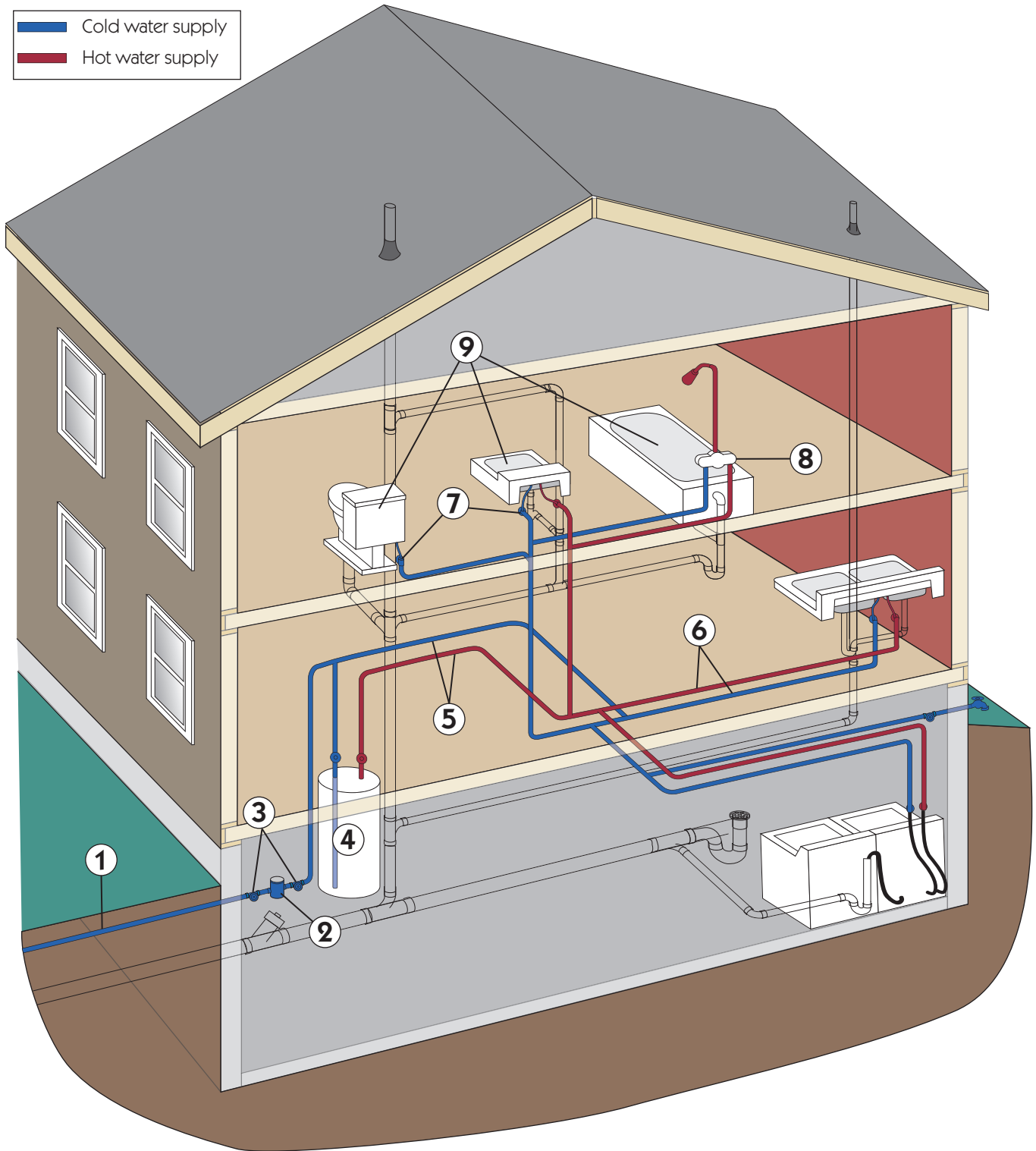
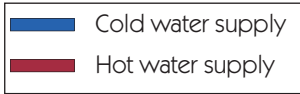

How It Works

The supply system is the network of pipes that delivers hot and cold potable water under pressure throughout the house.

1. Water enters underground from the street through a $\frac{3}{4}$ " or 1" metal pipe. In houses built prior to 1950, the metal is usually galvanized steel; after 1950, copper. In the case of a private water supply, the pipe is usually polyethylene.

2. If you pay for water and sewage, your home's usage is measured and recorded as the water passes through a water meter. If you find no meter inside the house, one is probably located in a pit between the house and the street. You can monitor your consumption, measured in cubic feet, by lifting the cap and reading the meter.

3. Next to the water meter (before, after, or both), you will find a valve, which allows shutting off the water supply, both cold and hot, to the entire house. If you have never noted this valve, do so now. When a pipe or fixture springs a leak, you don't want to waste time searching for it.

4. Water heaters are most often large, insulated, vertical tanks containing from 40 to 120 gallons. Cold water enters the tank from a pipe extending nearly to the tank bottom. Electric elements, a gas burner, or an oil burner heat the water to a pre-set temperature. When hot water is drawn from the top, cold water flows in at the bottom to replace it.

If the home is heated hydronically (with circulating water), the water heater may consist of a heat-exchange coil inside the boiler, or it may be a separate tank (BoilerMate™) heated with water from the boiler through a heat exchange coil.

Wall-mounted tankless water heaters provide a limited, but continuous, supply of hot water through a coil heated directly by gas or electricity.

5. Supply pipes—both cold and hot—that serve many fixtures are called "trunk lines," and are usually $\frac{3}{4}$ " in diameter. Pipes serving hose bibbs and other fixtures with high demands may be $\frac{3}{4}$ " as well.

6. Pipes serving only one or two fixtures are called "branch lines." Because they carry less water, they are often reduced in size to $\frac{1}{2}$ " and, in the case of toilets, $\frac{3}{8}$ ". Exceptions are pipes serving both a shower and another fixture.

7. Every fixture should have shutoff valves on both hot and cold incoming supplies. This is so that repairing the single fixture doesn't require shutting off the entire house supply at the meter valve.

8. A pressure-balanced anti-scald valve or thermostatic temperature control valve prevents the hot and cold temperature shocks we have all experienced when someone suddenly draws water from a nearby fixture. They are not inexpensive, but they provide insurance against scalds and cold-water shocks, which may trigger a fall in the elderly.

9. "Fixture" is the generic plumbing term for any fixed device that uses water.

Drain pipes are sized according to the rate of flow they may have to carry. One fixture unit (FU) is defined as a discharge rate of one cubic foot of water per minute. Plumbing codes assign bathroom sinks (lavatories) 1 FU, kitchen sinks 2 FU, and toilets (water closets) 4 FU.

1

PLUMBING

The Waste System

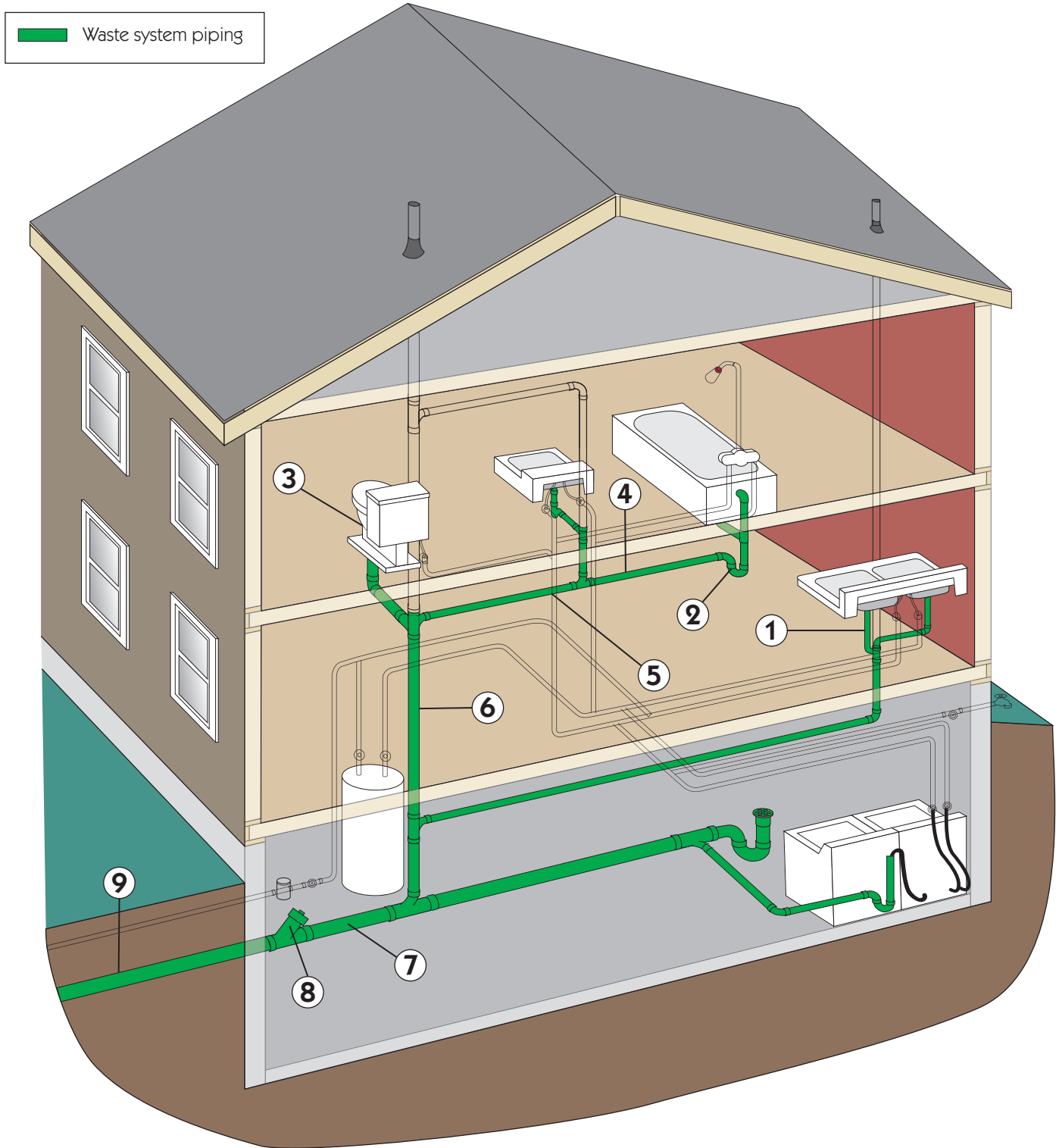

How It Works

The waste system is the assemblage of pipes that collects and delivers waste (used) water to either the municipal or private sewage system.

1. The pipe that drains away a fixture's waste water is its drain. The minimum diameter of the drain is specified by code and is determined by the rate of discharge of the fixture.

2. Each and every fixture drain must be "trapped." A trap is a section of pipe that passes waste water, but retains enough water to block the passage of noxious sewer gases from the sewage system into the living spaces of the house.

3. Toilets (water closets) have no visible trap, but one is actually there, built into the base of the toilet.

4. The horizontal section of drain pipe between the outlet of a trap and the first point of the drain pipe that is supplied with outdoor air is called the "trap arm." The plumbing code limits the length of the trap arm in order to prevent siphon action from emptying the trap. The allowed length is a function of pipe diameter.

5. As with a river, the smaller tributary drain pipes that feed into the main "house drain" are called "branches."

6. The largest vertical drain pipe, extending from the lowest point through the roof, and to which the smaller horizontal branch drains connect, is called the "soil stack." The term "soil" implies that the drain serves human waste. If it does carry human waste, and/or if it serves enough fixture units, it must be at least 3 inches in diameter. In a very horizontally extended house, there may be more than one soil stack.

7. The largest, bottom-most horizontal waste pipe is the "house drain." In a delicate balance between too-slow and too-rapid flow of waste, the house drain (and all other horizontal waste pipes) must be uniformly inclined at between $\frac{1}{8}$ " and $\frac{1}{4}$ " per foot. In a basement or crawl space, the house drain is usually exposed. With a slab-on-grade foundation, the house drain is beneath the slab.

8. To facilitate unclogging of drain pipes, Y-shaped "cleanouts" are provided. At a minimum, there will be a 4" diameter cleanout at the point where the house drain exits the building. This cleanout is utilized when tree roots invade the exterior drains and special drain-reaming equipment must be called in to cut the roots. Additional cleanouts are required throughout the waste system for every 100' of horizontal run and every cumulative change of direction of 135 degrees.

9. Waste pipe outside of the building line is termed the "house sewer." It is always at least 4" in diameter.

1

PLUMBING

The Vent System

 Vent system piping

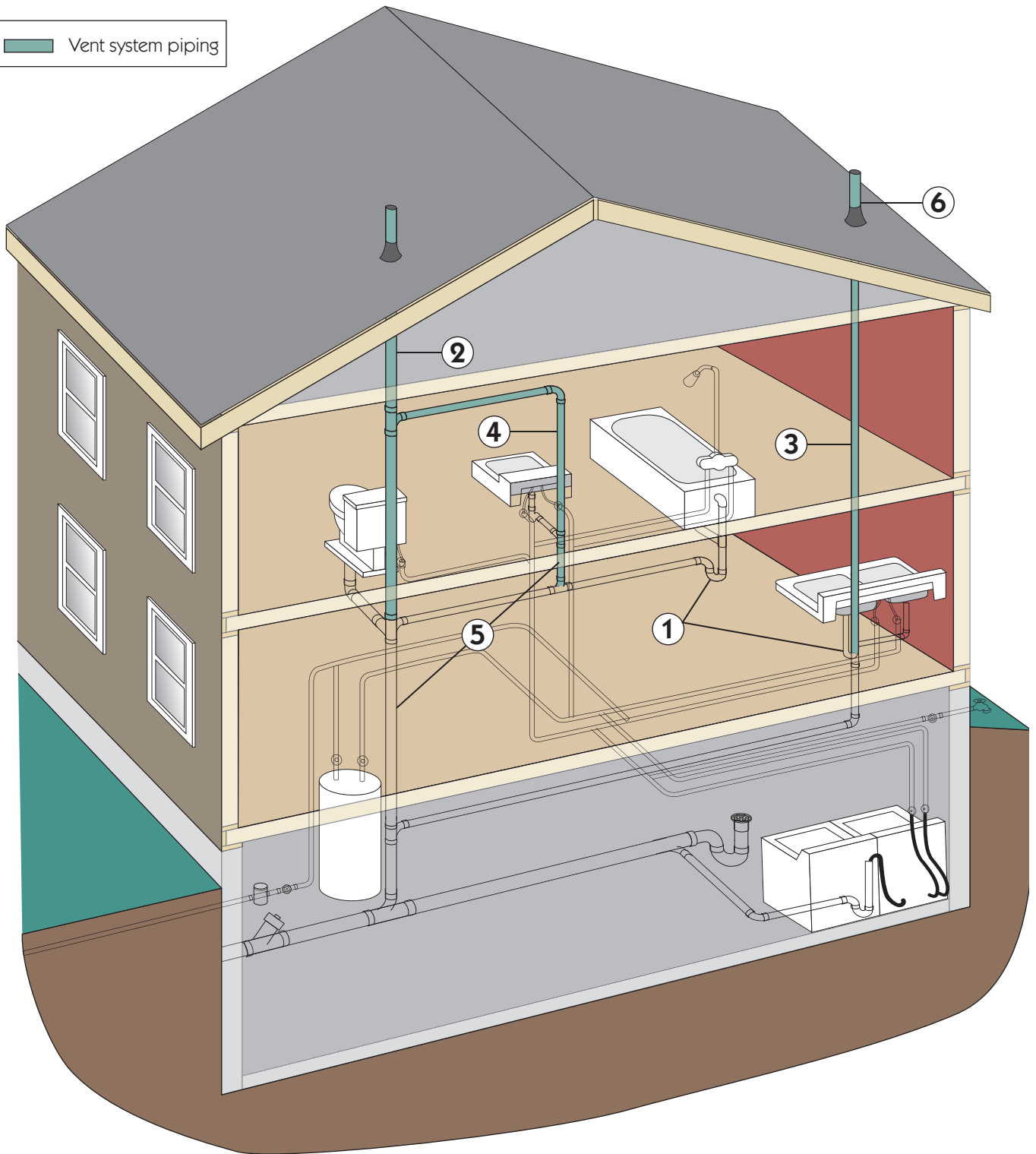

How It Works

As you can see on pages 18 and 19, fixture drains must be kept at atmospheric pressure so that the water seals in their drain traps are not siphoned away, thereby exposing the interior of the house to noxious sewer gases. The vent system consists of the pipes that relieve pressure differences within the drain system.

1. All plumbing fixtures (things that use and discharge waste water into the drain system) possess traps. To prevent waste water from forming a siphon during discharge, air must be introduced into the drain pipe near the outlet of the trap (maximum distance determined by the drain pipe diameter).

2. The primary vent is part of a large-diameter vertical pipe termed the “stack.” Below the highest point of waste discharge into it is the “waste stack.” Above that point it is the “vent stack.” If a waste stack also serves one or more toilets (and it usually does), it is sometimes called the “soil stack.” Because it provides a direct air passage to the municipal sewer pipe or private septic tank, a vent stack must be terminated in the open air. And to keep the sewer gas as far as possible from people, it is usually terminated through the roof.

3. The permitted length of drain pipe from a trap to a vent (the trap arm) is specified by code as a function of the pipe diameter. (See page 19.) If the horizontal run of the drain is very long, a smaller-diameter vent stack is usually provided close after the trap.

4. Another solution to the too-long horizontal drain is to break it into legal lengths with “revents.” To guarantee that they are never blocked with water, revents connect to the vent stack at least 6" above the flood level of the highest fixture on the drain. A horizontal drain may be revented as many times as required.

Where reventing is impractical—such as in the case of an island sink—a “loop vent” can be provided. The loop vent (also known as a “barometric vent”) does not connect to the vent stack. Instead, it provides pressure relief simply by the volume of its contained air.

Another solution, allowed only for single fixtures in locations precluding regular venting, is the “automatic vent.” This is an air check valve, which allows house air to flow into the drain, but prevents sewer gas from escaping.

5. A vertical vent pipe is allowed to serve as a combined waste and vent, provided its diameter is sufficiently large. Sections of pipe serving both purposes are called “wet vents.”

6. The air in vent pipes is at 100% humidity. In northern states, where the average daily temperature is below freezing for extended periods, frost can build up on the inside of exposed vents. To avoid complete frost blockage, local codes may specify a larger diameter for the section of vent above the roof. In addition, so that snow does not cover the vent pipe, a local code may also call for a vertical extension of the pipe beyond the code minimum of 6".

Private Septic System

Drain Field Downslope

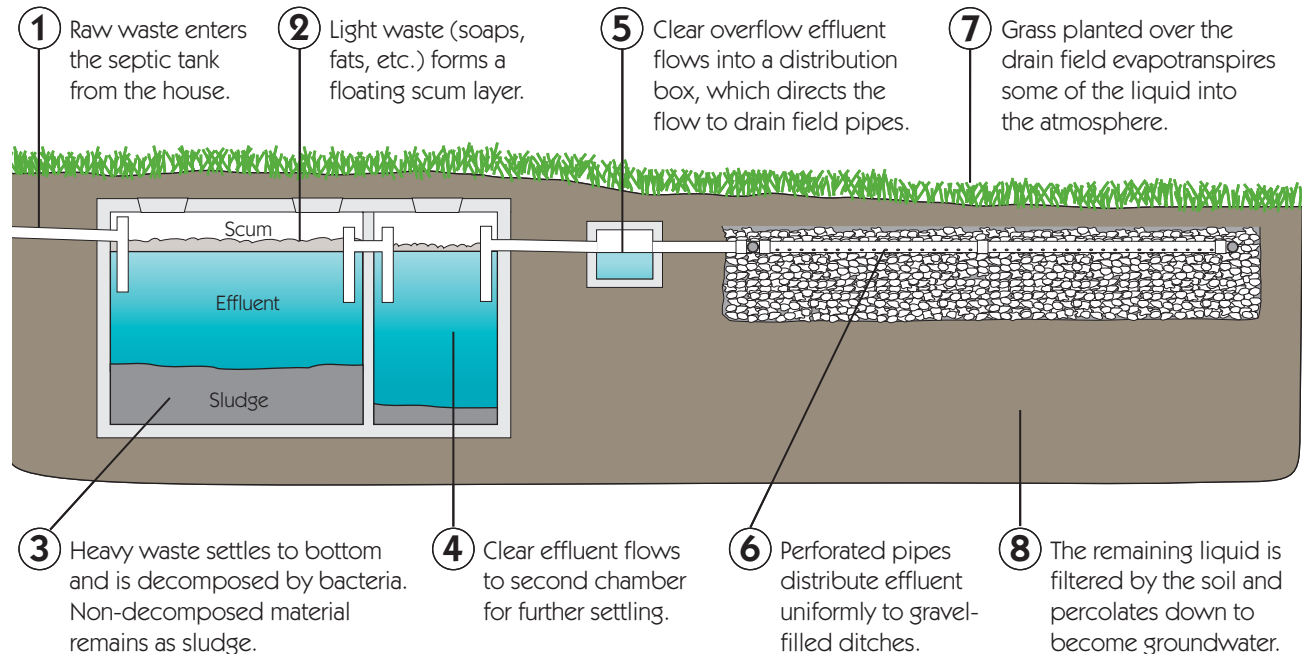

How It Works

Drain Field Upslope

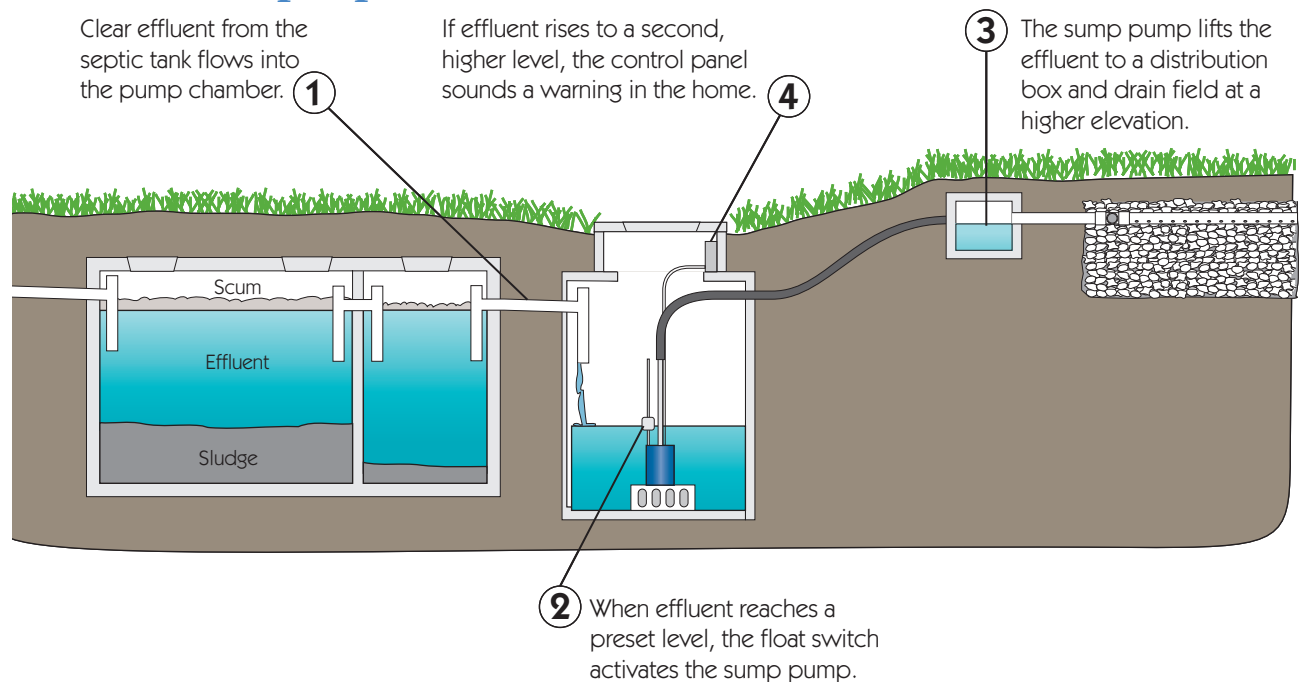

Keeping It Working

If too much sludge accumulates in the septic tank, solid waste may flow straight through and reach the pipes in the drain field. It will then clog the pipes and the gravel trenches, rendering the drain field ineffective.

Your system is failing if you observe one or more of the following:

- Slow drains throughout the house.
- A persistent wet area over, or next to, the drain field.
- Sewage seeping through the foundation.

Most jurisdictions will require a fouled system to be replaced in its entirety—a very expensive job. To prevent this from happening and to maximize your system's useful life, here are lists of do's and don'ts.

Do:

- Spread automatic washer use over the week.
- Record and keep in a safe place the location of the septic tank and distribution box.
- Have your septic tank checked every two years for a family of four, and four years for a family of two.
- Keep a log of pump-outs.
- Practice water conservation.
- Keep trees with large root systems far from the drain field.
- Plant grass over the drain field.
- Compost kitchen waste or dispose of it in your garbage.
- Use only RV antifreeze if winterizing your plumbing.

Don't:

- Drain a basement sump pump to the septic system.
- Drain backwash from water treatment equipment to the system.
- Use septic tank additives, in spite of manufacturers' claims.
- Use garbage disposers.
- Drive or park on the drain field.
- Plant anything but grass over the drain field.
- Flush paints, varnish, fats, grease, waste oil, or chemicals.
- Flush paper towels, sanitary napkins, tampons, disposable diapers, dental floss, condoms, kitty litter, cigarettes, or pesticides.

Lavatory Pop-up Drains

How It Works

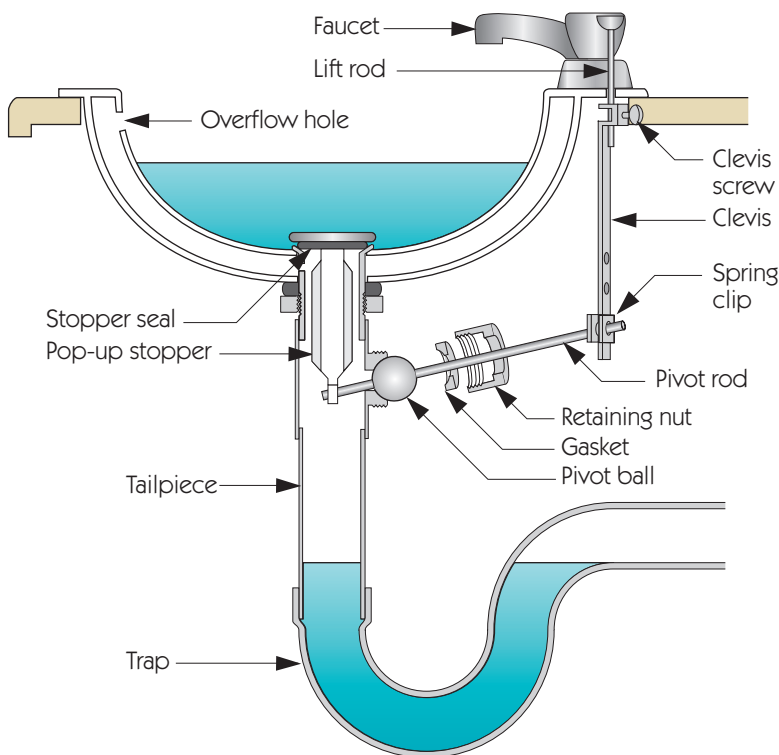
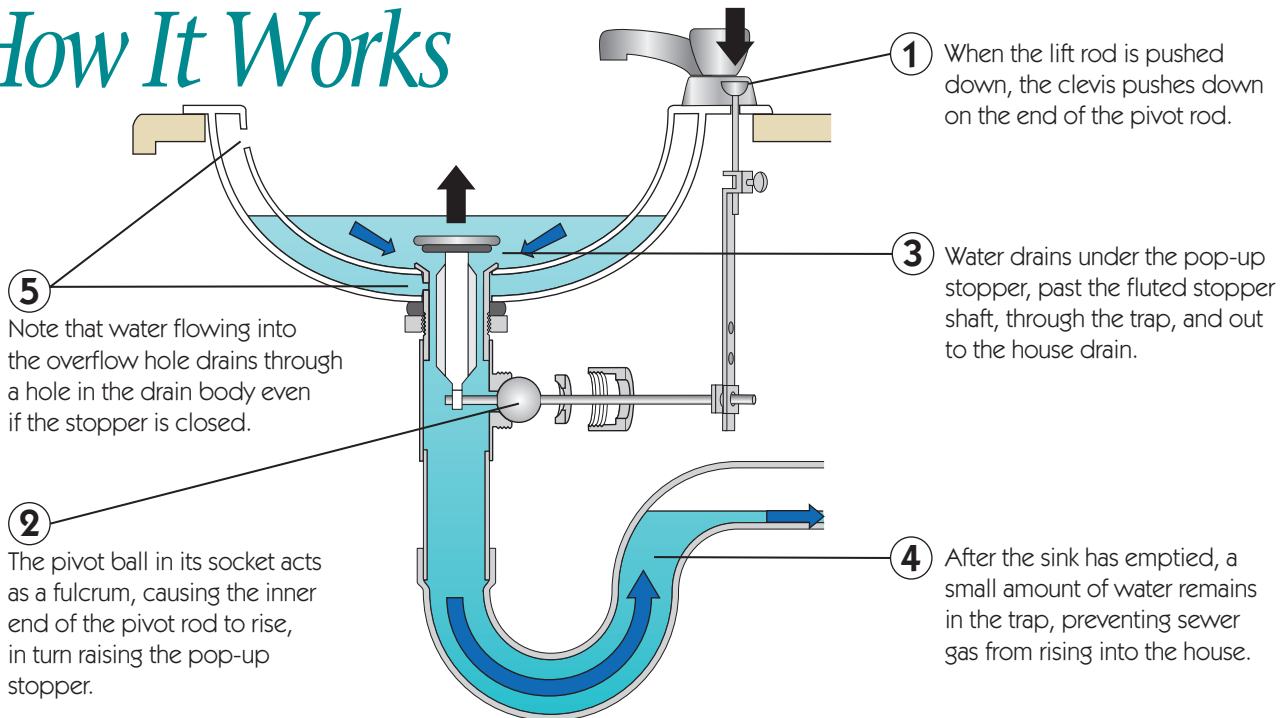

Before Calling a Plumber

To adjust the height of the stopper, loosen the clevis screw and reposition the lift rod, or move the end of the pivot rod to a different hole in the clevis.

If the stopper won't remain in the open or closed position, tighten the retaining nut to grip the pivot ball more firmly.

To remove or replace the pop-up stopper, or to insert a drain auger, unscrew the retaining nut, remove the pivot rod, and lift the stopper out.

Replacement kits are available for entire pop-up assemblies at hardware stores and home centers.

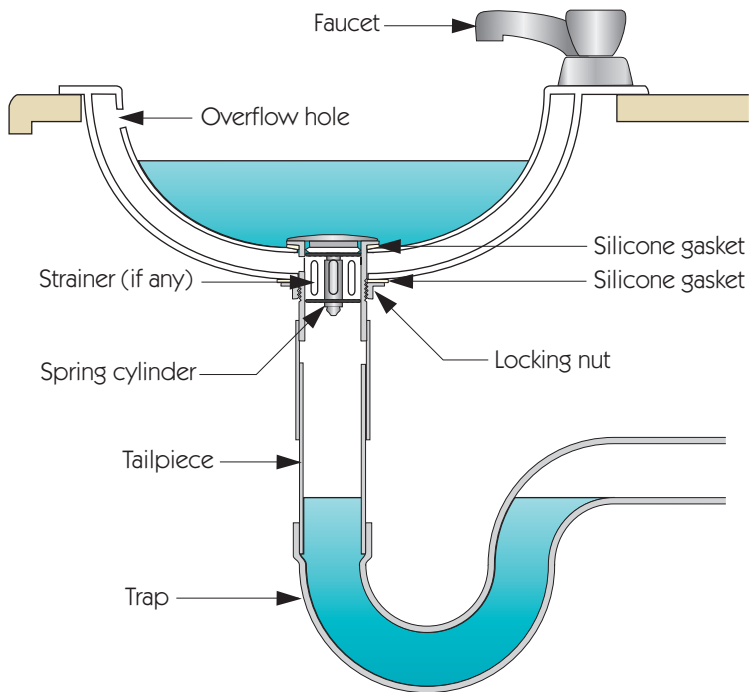
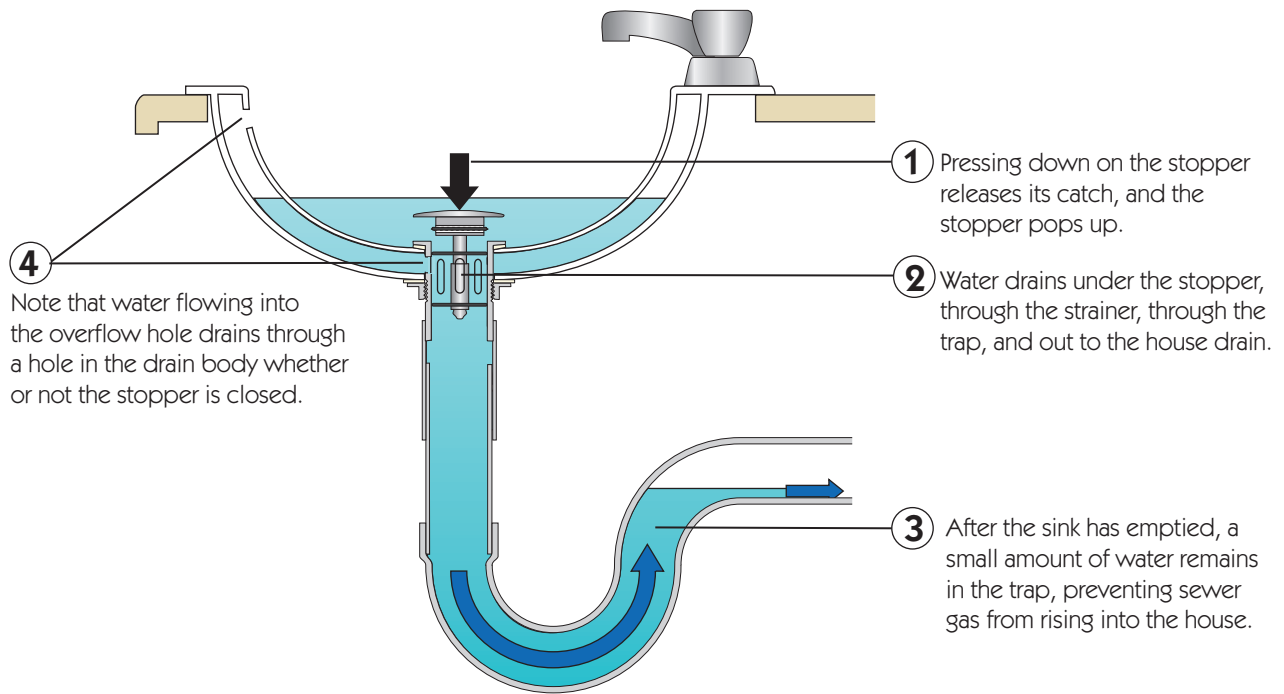

Before Calling a Plumber

If the sink is draining too slowly, chances are the strainer is clogged with hair. Press down on the stopper to pop it up. Then unscrew the cap (CCW).

The result will be either: 1) the whole assembly will come out, or 2) you will see a screw that needs to be removed to release the rest of the device.

Use Q-tips or tweezers to remove the clogging material, and replace the screw and cap.

Note: older pop-up drains shown on the previous page can be replaced with this type of drain with DIY kits found at home centers.

Plunger-Type Tub Drain

How It Works

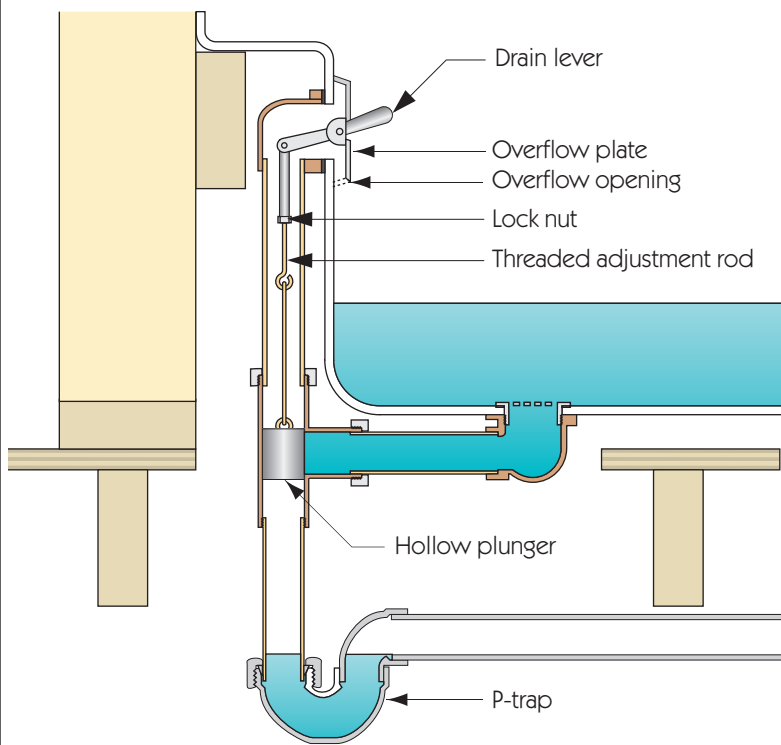
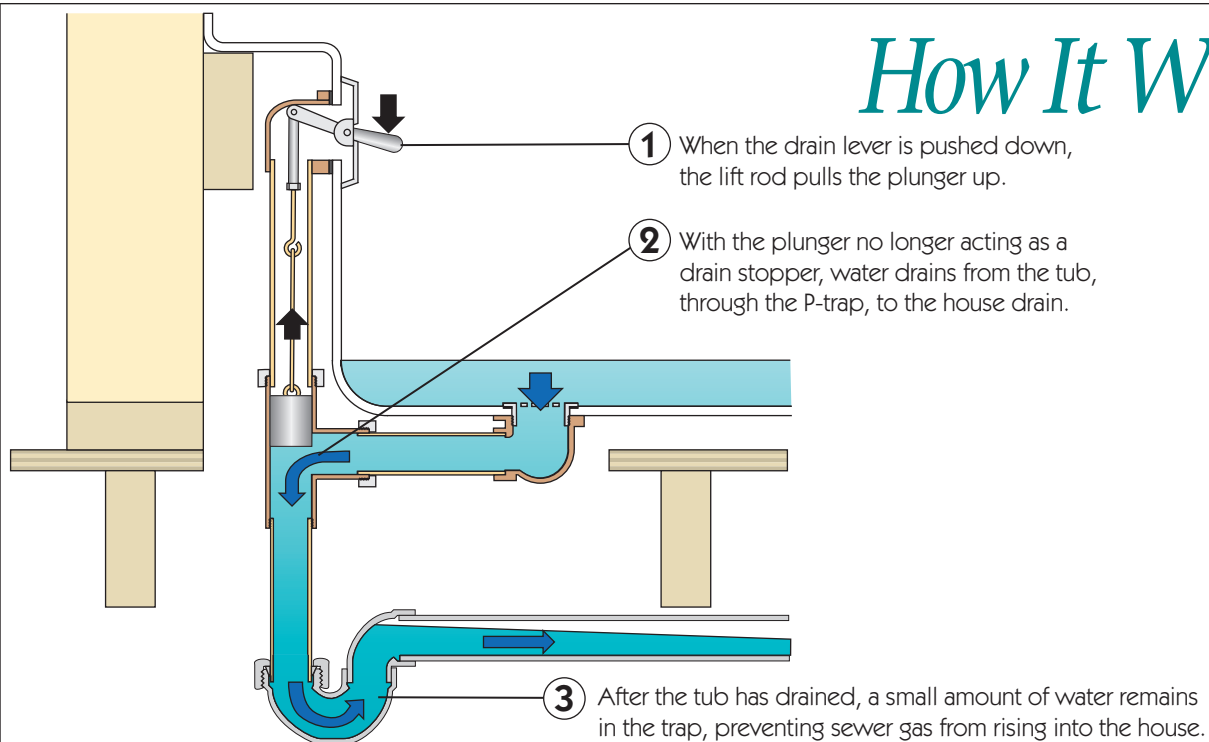

Before Calling a Plumber

If the tub won't retain water with the drain lever up, chances are the plunger is either too high or too low to block the drain completely. Remove the overflow plate and plunger assembly. Shorten or lengthen the adjustment rod, reassemble, and try again. If the adjustment makes the leak worse, readjust the rod—this time in the opposite direction.

If the tub drains too slowly with the drain lever down, the drain is probably clogged. Remove the overflow plate and plunger, and feed a drain auger down the opening to clear the blockage.

Pop-up Tub Drain

How It Works

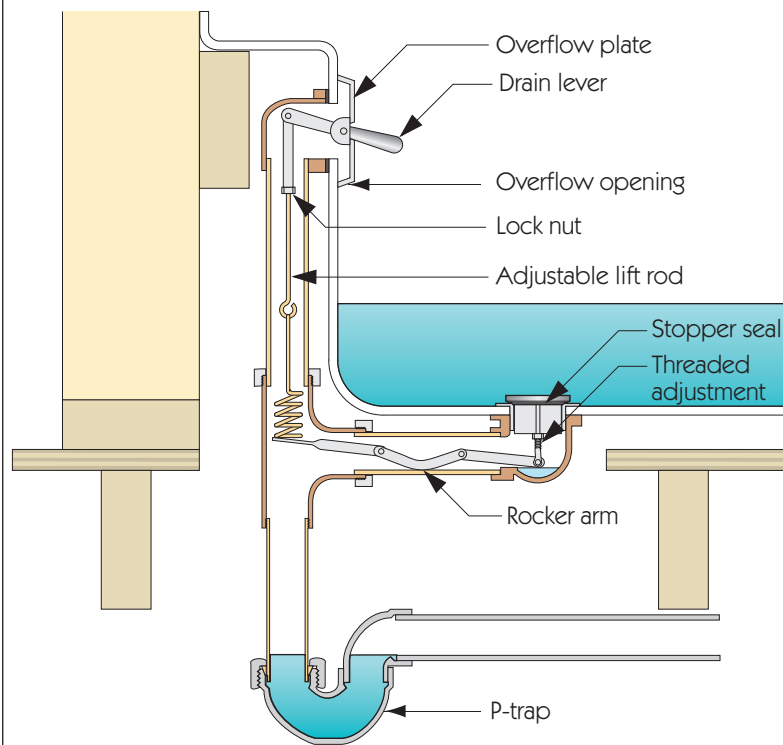
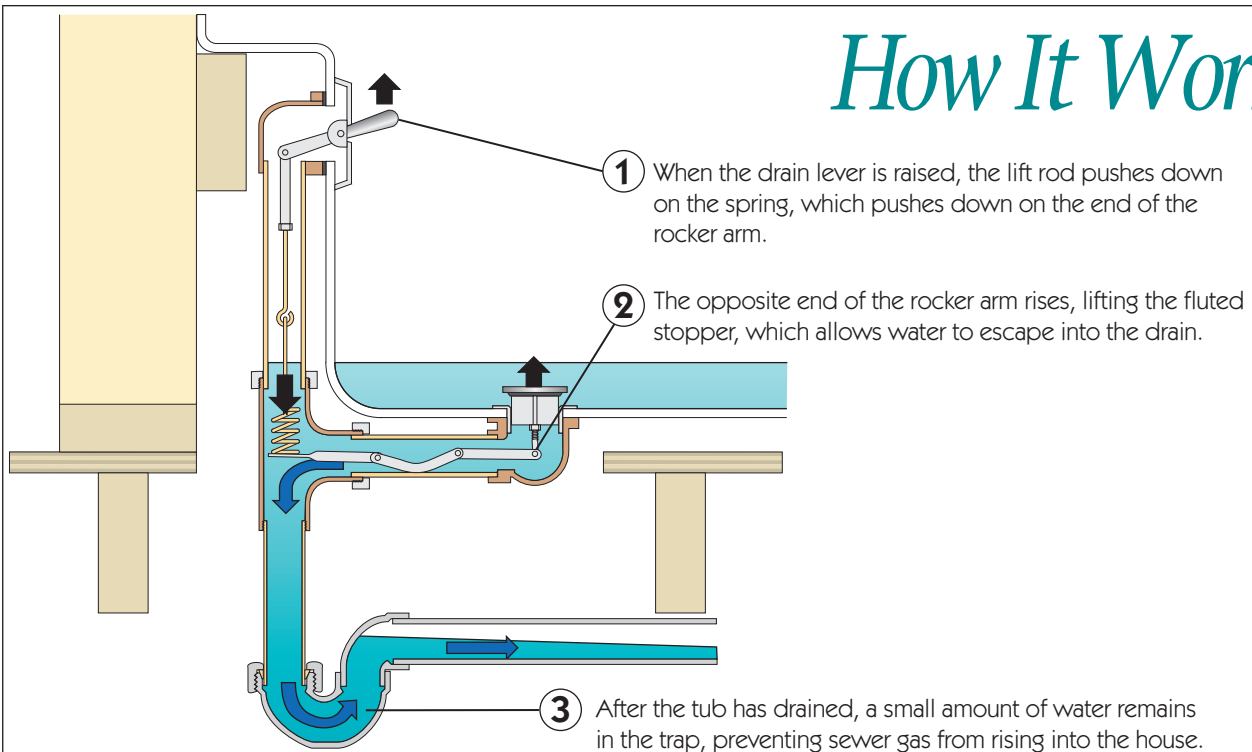

Before Calling a Plumber

If the tub won't retain water with the drain lever down, and the stopper is firmly seated, replace the rubber stopper seal.

If the tub drains too slowly with the drain lever up, remove the stopper assembly. Turn the stopper counter-clockwise several turns to increase its height, and retighten the stop nut. Replace assembly and test the flow.

If the tub still drains too slowly, the drain is clogged. Remove both drain lever and stopper assemblies, and feed a drain auger down the drain lever opening to clear the blockage.

Older Gravity Flow Toilet

How It Works

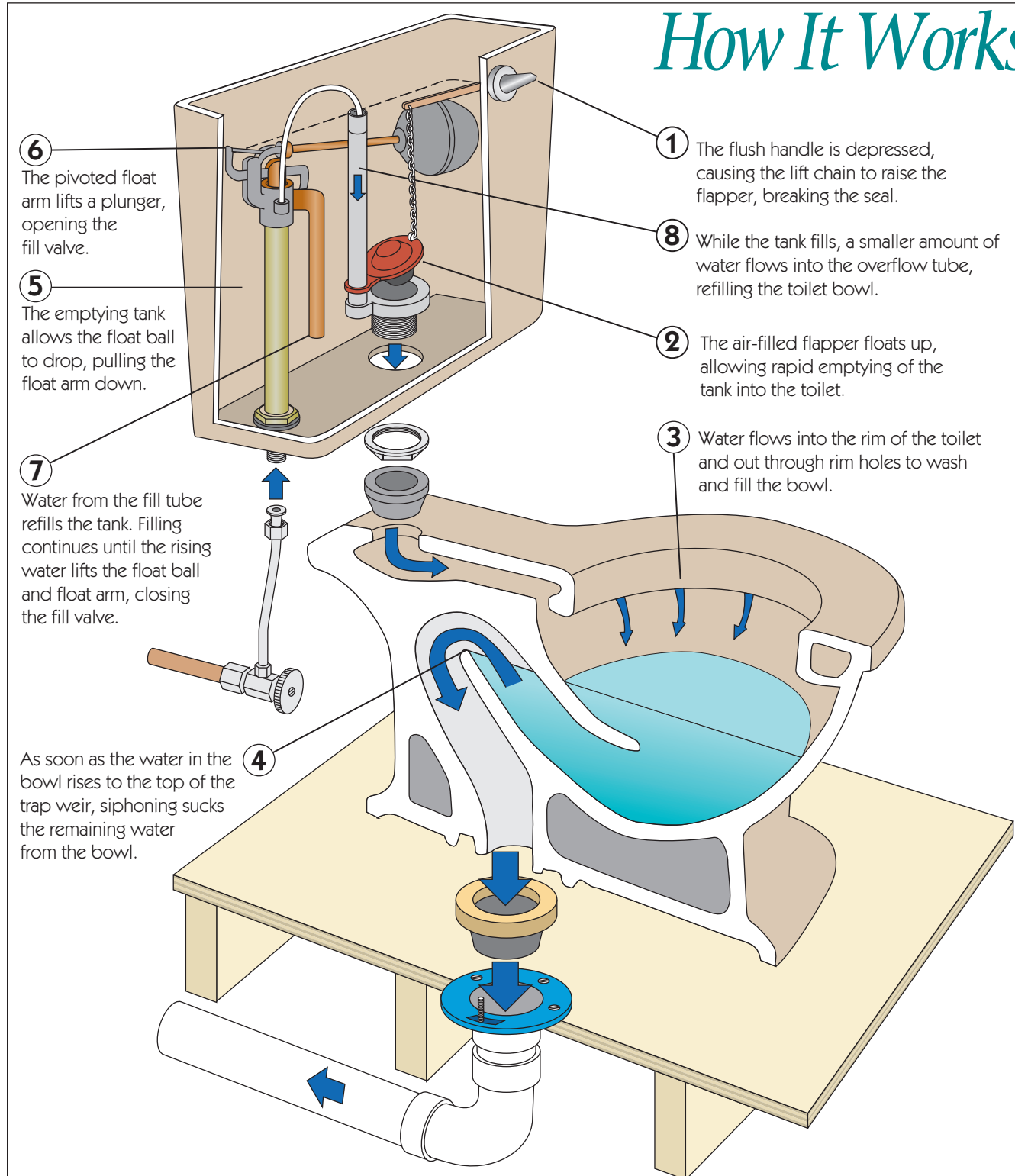

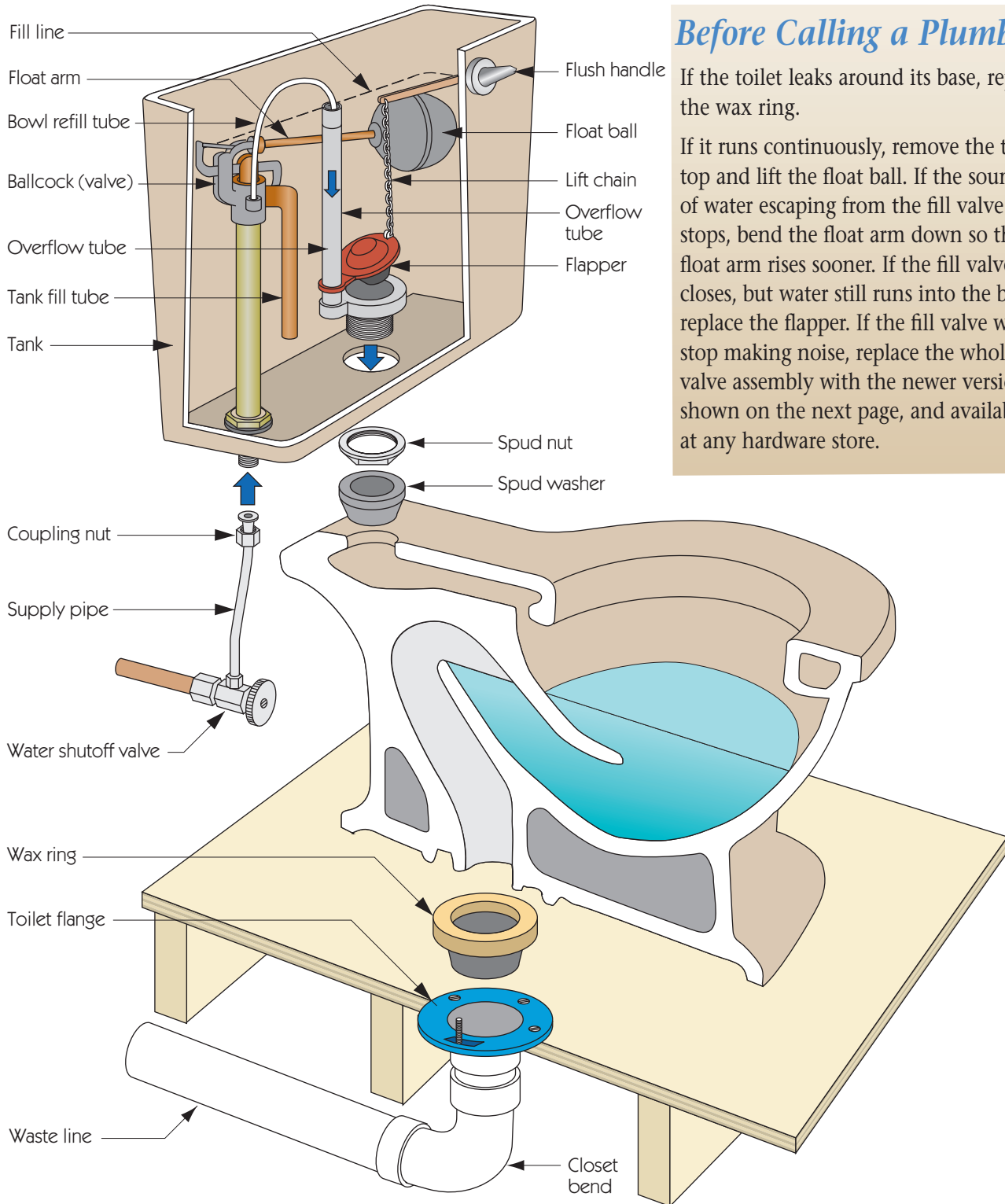

Before Calling a Plumber

If the toilet leaks around its base, replace the wax ring.

If it runs continuously, remove the tank top and lift the float ball. If the sound of water escaping from the fill valve stops, bend the float arm down so the float arm rises sooner. If the fill valve closes, but water still runs into the bowl, replace the flapper. If the fill valve won't stop making noise, replace the whole fill-valve assembly with the newer version, shown on the next page, and available at any hardware store.

Water-Saving Toilet

How It Works

6

The pivoted float arm lifts a plunger, opening the fill valve.

5

The emptying tank allows the float cup to drop, pulling the float arm down.

7

Water from the fill tube flows through the fill valve, refilling the tank. Filling continues until the rising water lifts the float cup and float arm, closing the fill valve.

As soon as the water in the bowl rises to the top of the trap weir, siphoning sucks the remaining water from the bowl.

4

1

The flush handle is depressed, causing the lift chain to raise the flapper, breaking the seal.

8

While the tank fills, a smaller amount of water flows into the overflow tube, refilling the toilet bowl.

2

The air-filled flapper floats up, allowing rapid emptying of the tank into the toilet.

3

Water flows into the rim of the toilet and out through angled rim holes to wash and fill the bowl.

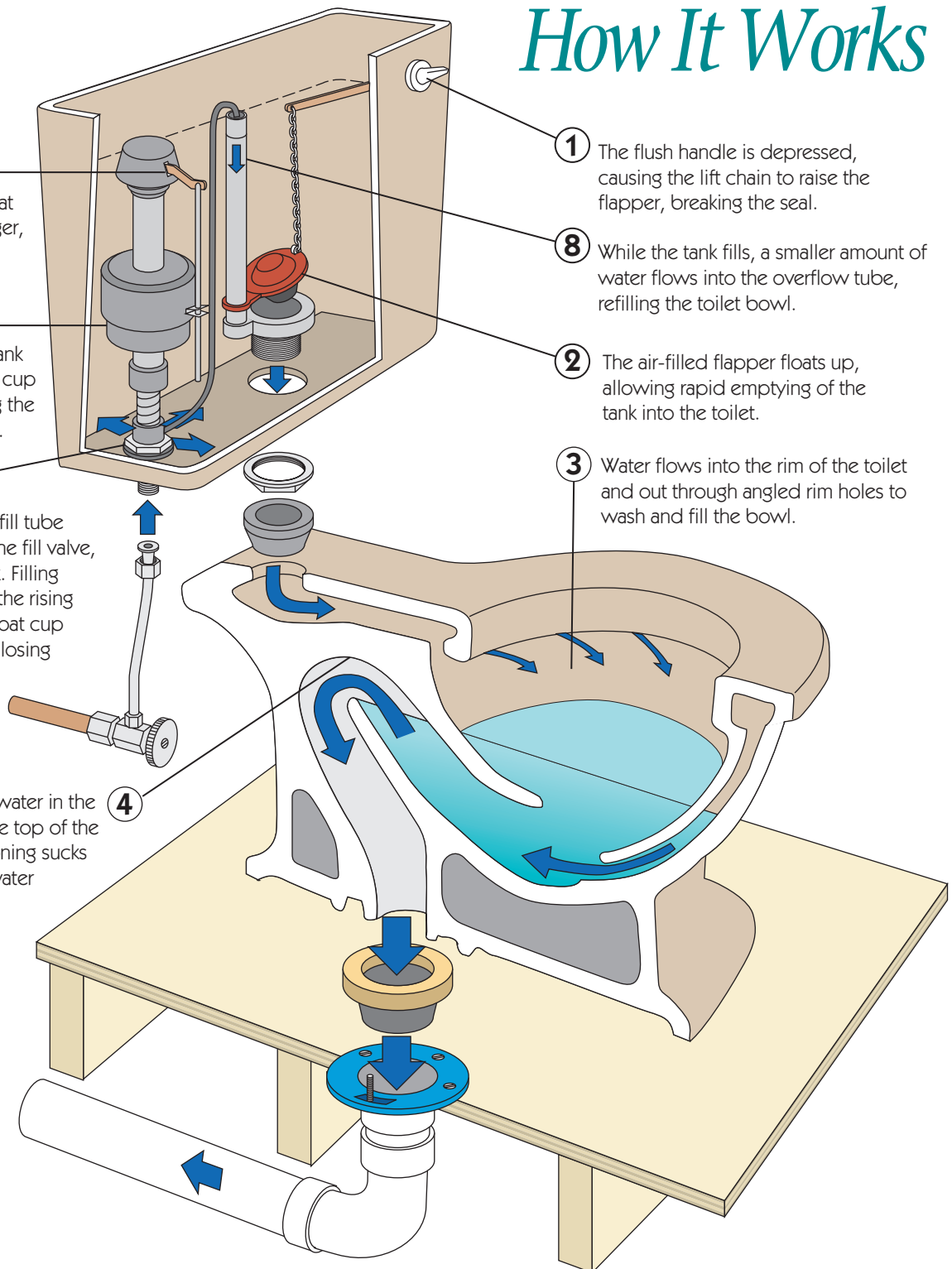

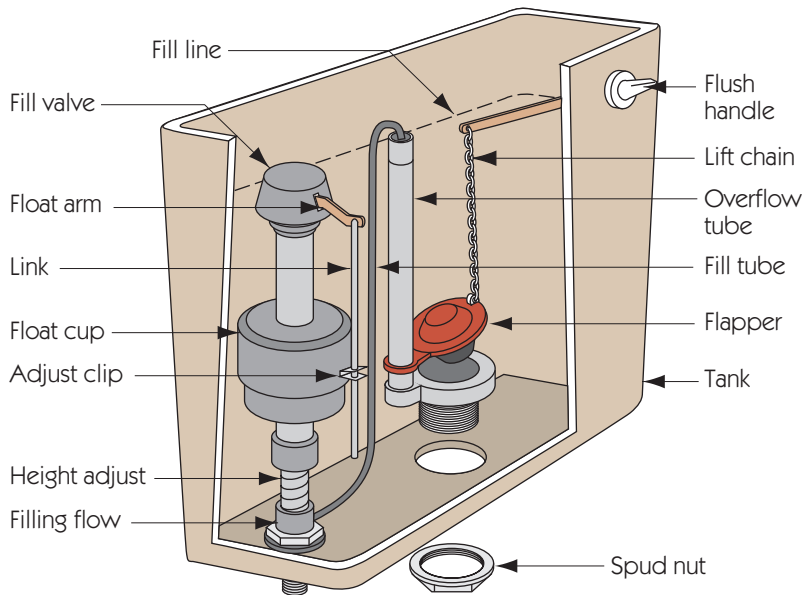

Before Calling a Plumber

If the toilet leaks around its base, replace the wax ring.

If it runs continuously, remove the tank top and lift the float arm. If the sound of water escaping from the fill valve stops, adjust the clip on the float cup so the float arm rises sooner. If the fill valve closes, but water still runs into the bowl, replace the flapper. If the fill valve won't stop making noise, replace the whole fill-valve assembly.

A broken or disconnected lift chain can be repaired with a small plastic wire tie.

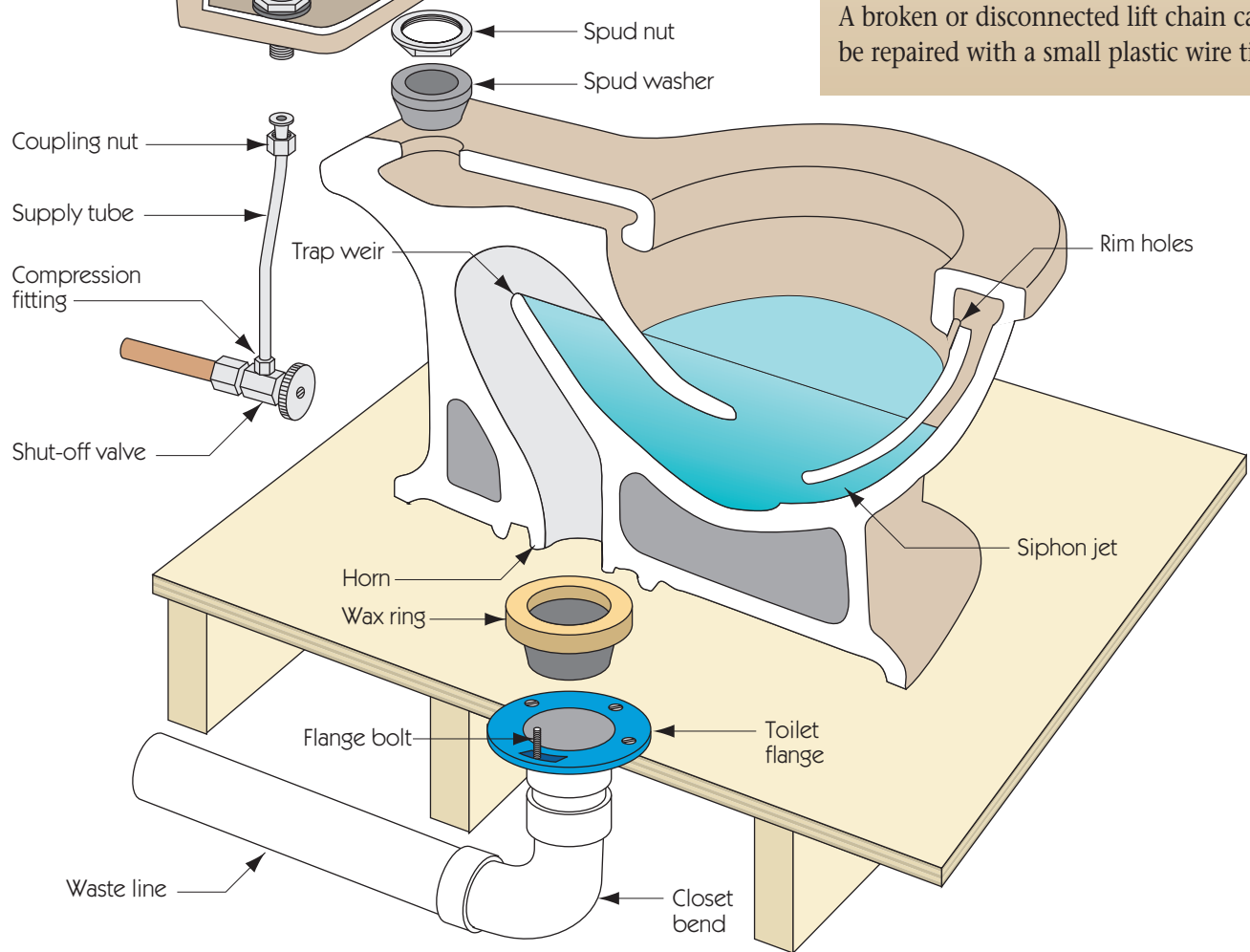

Composting Toilet

How It Works

One solution to the world's growing scarcity of fresh water is the composting toilet. Such toilets bring the natural process of composting animal (humans are animals, too) feces into organic fertilizer.

By separating solids (feces) from liquids (urine), unpleasant odor is minimized, and the ideal moisture content of the compost is easily maintained. Best of all, both the urine and resulting compost are easily disposed of.

Nature's Head® Composting Toilet

Lid, normally closed, opens for use.

Pushing handle down opens the trap door, allowing feces to be deposited into the solids chamber.

Urine collected here flows into 2 gal. bottle.

Urine bottle emptied every 2-4 days.

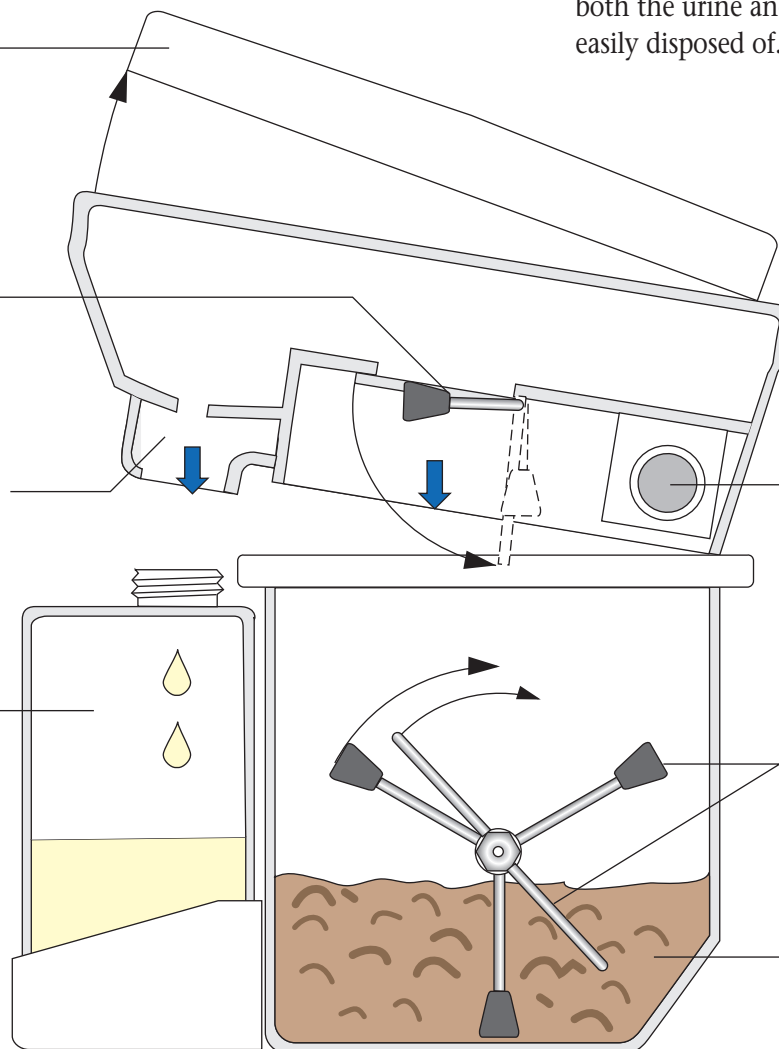

12-VDC fan draws air continuously through upper chamber and pushes it through a hose to an external vent, thus preventing odors.

Turning agitation handle slowly several slow turns rotates interior arms, stirring damp, crumbly compost after each use.

For two people, feces, composted with organic sphagnum peat moss, is removed every 3 weeks.

Traps & Vents

How They Work

P-Trap

Older homes may contain many types of traps. (See “Prohibited Older Traps,” opposite.) Of all the traps, the “P” has proven most successful at resisting siphonage, so most codes now require it.

The reasons for its success are:

- 1) the depth of its water seal, and
- 2) its horizontal trap arm. Unless the arm is long enough to cause a friction backup to the top of the pipe, a siphon is never formed.

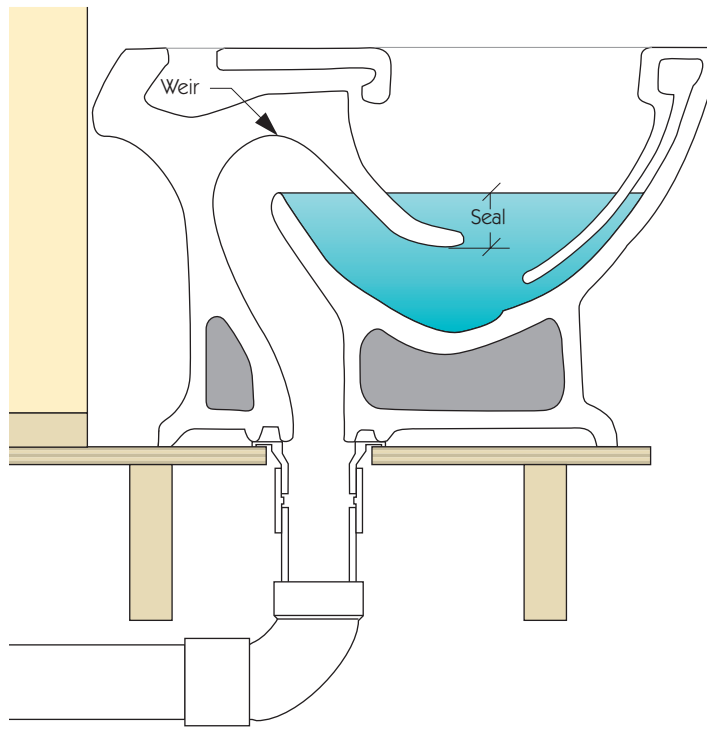
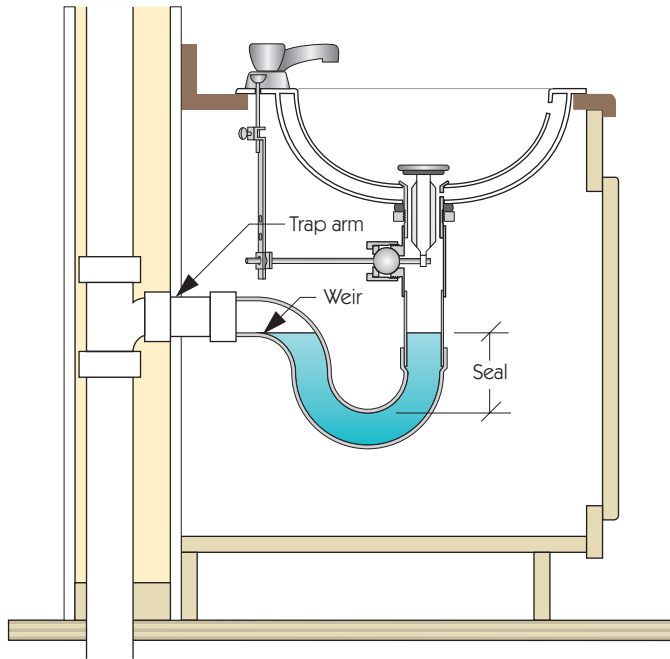

Water Closet Trap

Invisible to the eye, the water chambers inside a toilet base actually form an S-trap.

S-traps have been generally banned due to their propensity to siphon, leaving an imperfect water seal against sewer gases. The toilet gets around this problem by diverting a small flow of water to the bowl through the fill tube while the tank is refilling. (See page 14.)

Ball-Type Faucet

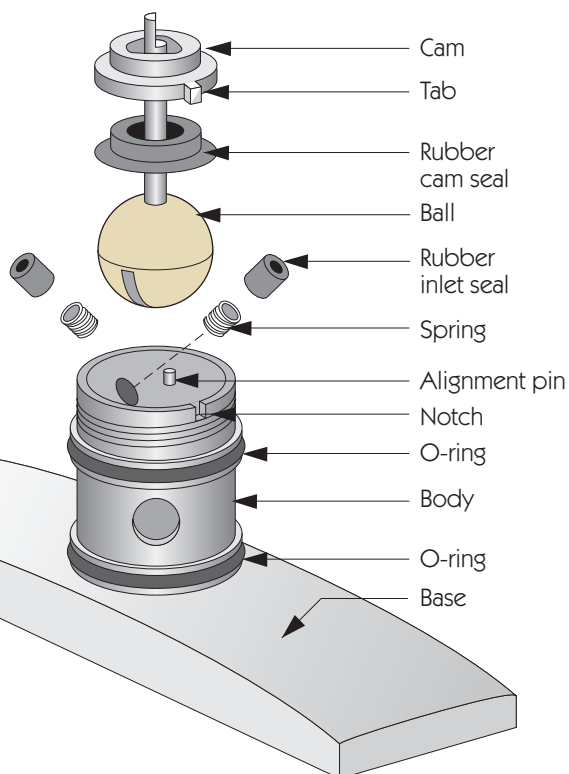
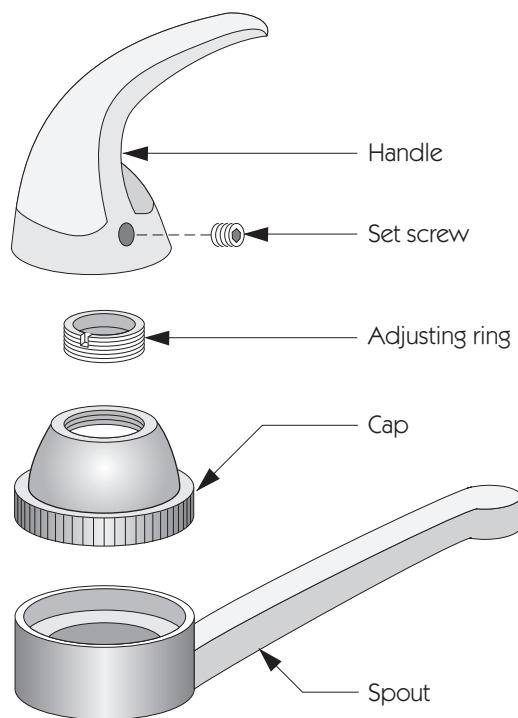

How It Works

Inside the faucet body is a hemispherical recess with a fixed alignment pin and three holes: a cold-water inlet, a hot-water inlet, and a mixed water outlet. The hollow ball (plastic, brass, or stainless steel) is slotted. Moving the faucet handle rotates the ball up and down, and from side to side.

Up-and-down handle motion opens and closes the outlet, thus controlling the flow.

Side-to-side motion uncovers more or less of the two inlets, thus controlling the proportion of hot and cold and the resulting mixed temperature.

Before Calling a Plumber

If the faucet leaks from under the handle, remove the handle and tighten the adjusting ring inside the cap.

If water leaks from under the spout, remove handle, cap, and spout. Replace the two large body O-rings, lubricate with petroleum jelly, and reassemble.

If the spout drips, the rubber inlet seals are likely worn. To replace the seals, remove the handle and cap, and lift out the ball. Pluck out the seals (2) and springs (2) and replace them. If this doesn't work, replace the ball—preferably with a stainless steel one.

Cartridge-Type Faucet

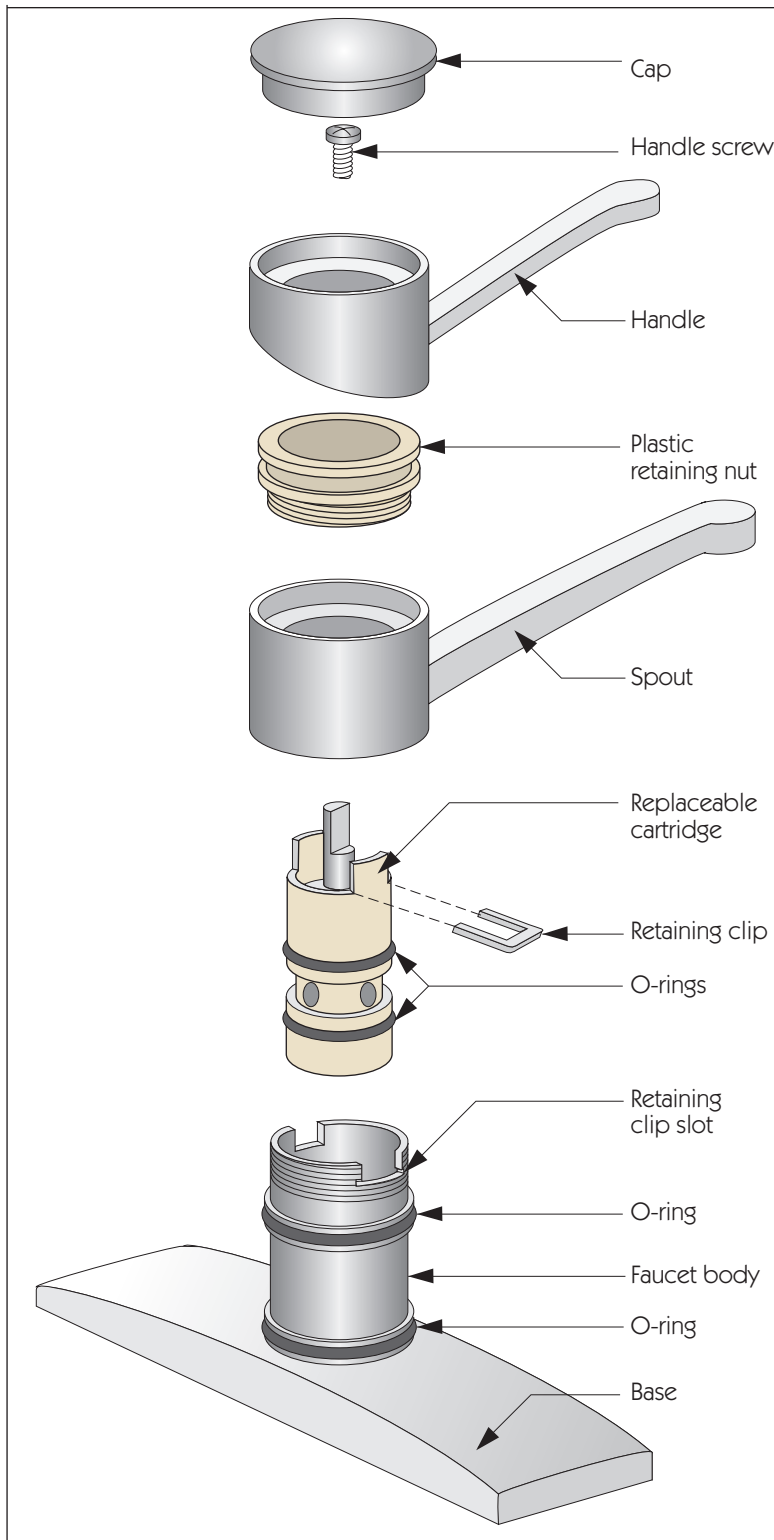

How It Works

Except for the compression-type, the cartridge-type faucet is the simplest because it has only one replaceable part—the cartridge.

There are dozens of differing cartridges, but all operate on the same principle: the cartridge is moved up and down and rotated to change the alignment of holes in the cartridge and faucet body, thus controlling the amounts of hot and cold water flowing to the spout.

If buying a replacement cartridge, take the old one with you to compare to the dozens you will find at the hardware store or home center.

Before Calling a Plumber

If the spout won't stop dripping, the cartridge is at fault. Remove the cap, handle, retaining nut, and retaining clip. Then extract the cartridge. This may require twisting and considerable force.

First, try replacing the O-rings on the cartridge. Make sure the new ones are identical to the old, and apply petroleum jelly before reassembly. If that doesn't work, replace the entire cartridge.

If, instead, the leak is from under the spout, remove the handle, cap, and spout. Replace the two large body O-rings, lubricate with petroleum jelly, and reassemble.

Disk-Type Faucet

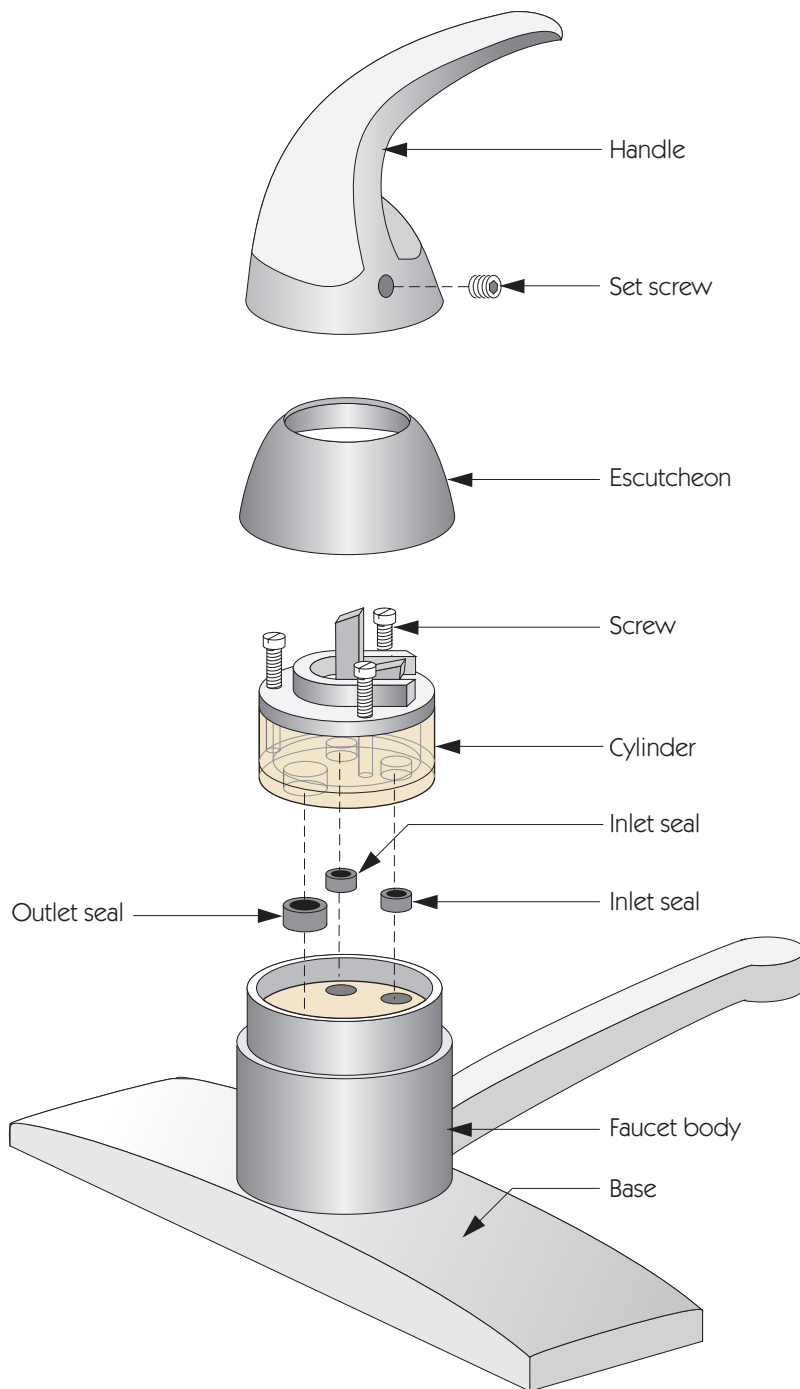

How It Works

The heart of the disk faucet is a cylinder containing two polished, fire-hardened ceramic disks, each containing two inlet and one outlet ports.

The bottom disk is fixed, while the handle rotates the upper disk, changing the proportion of incoming hot and cold water. Up-and-down handle motion opens and closes the outlet, thus controlling the flow.

Trouble rarely develops between the disks inside the cartridge. If a leak develops, it is likely due to the rubber seals under the cartridge or the spout O-rings.

Before Calling a Plumber

If the faucet won't stop dripping, remove the handle by loosening its set screw. Remove the escutcheon. Remove the screws in the cylinder, and lift the cylinder out. Take the cylinder to a home center for identification, and replace the three rubber seals on the bottom of the cylinder. After reassembling, lift the handle to its open position before turning on the water supply.

If water leaks from under the spout, remove the handle, escutcheon, cylinder, and spout. Replace the two large body O-rings, lubricate with petroleum jelly, and reassemble.

Compression-Type Faucet

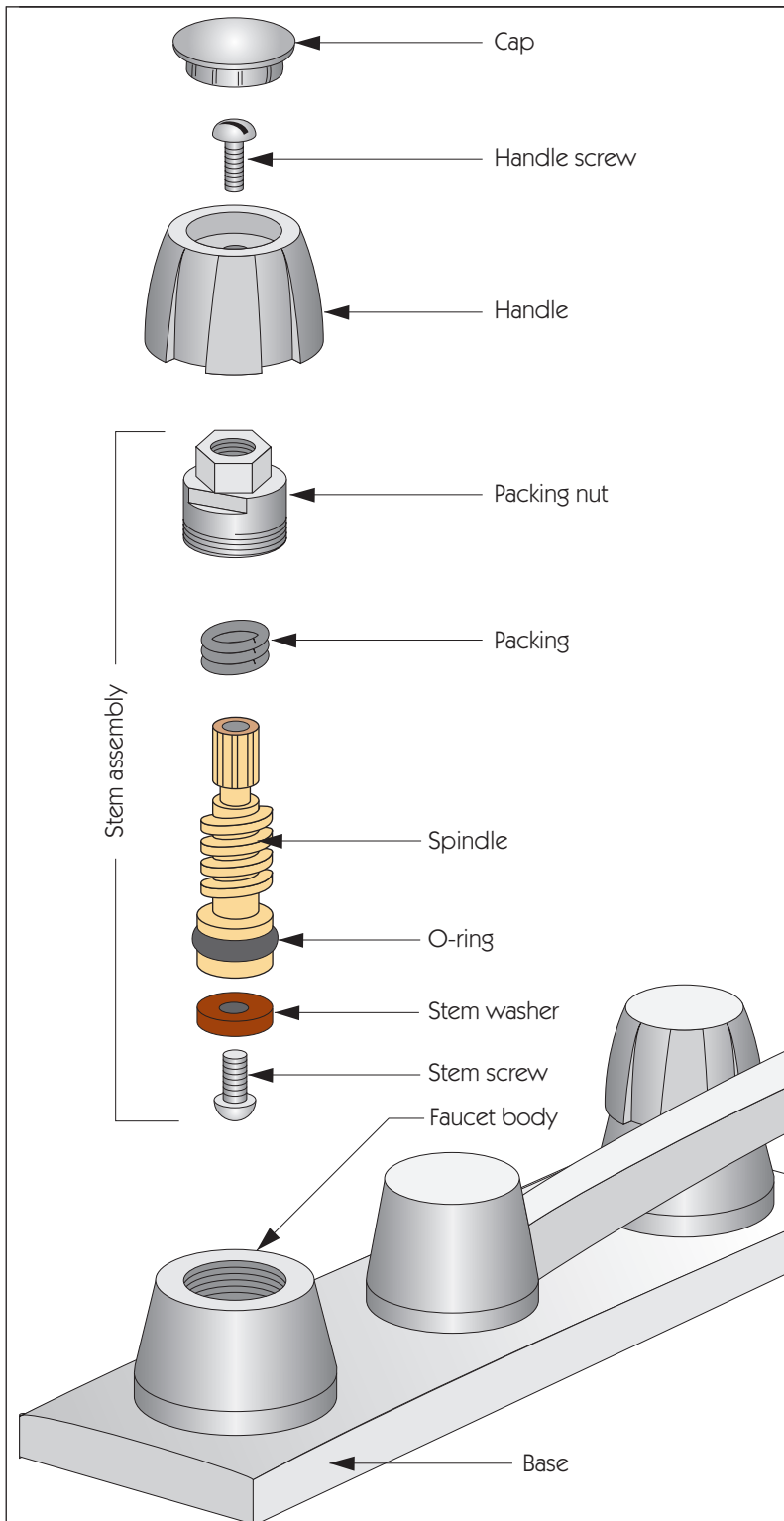

How It Works

Compression faucets have separate handles for hot and cold water. At the bottom of each stem assembly is a rubber washer. Turning the handle clockwise screws the stem in and down, reducing the space between the washer and the valve seat at the bottom. Turn the handle far enough, and the washer seats firmly against the valve seat, shutting off all flow.

The water that passes through the washers on both sides is mixed and emerges from the spout.

Before Calling a Plumber

If the spout won't stop dripping, or it requires excessive force to stop the dripping, the rubber washer(s) are worn out. Remove the caps and handles, remove the packing nuts, and turn the spindle assemblies out of the faucet bodies. Replace the stem washers and screws with identical parts, and reassemble.

If water leaks from under a handle, remove the handle and packing nut, and add a few turns of graphite or Teflon packing inside the packing nut. Tighten the packing nut just until the leaking stops, and replace the handle.

Tempering Valve

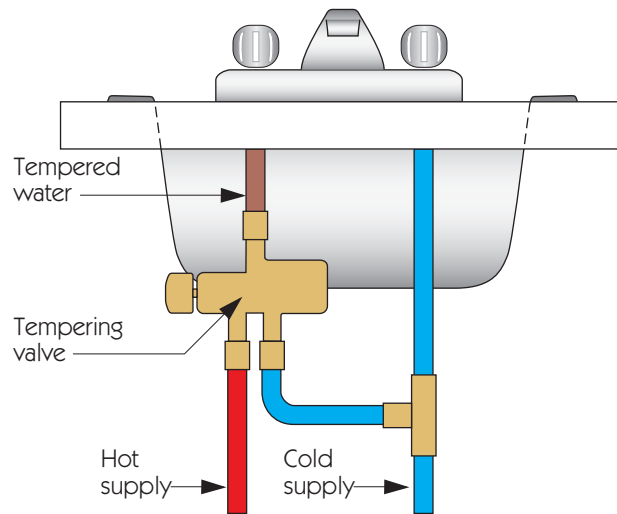

The tempered water is at 120°F. ①

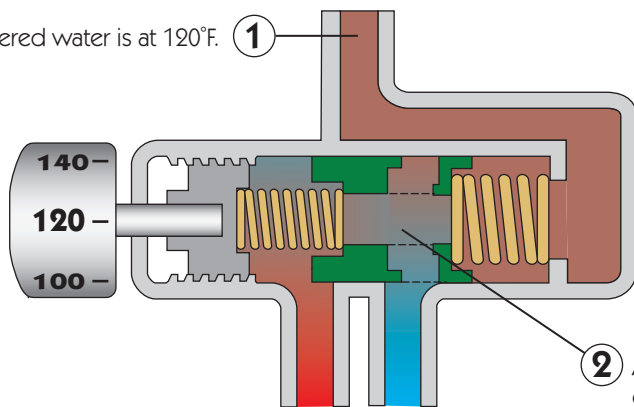

The tempered outflow is restored to 120°F. ⑤

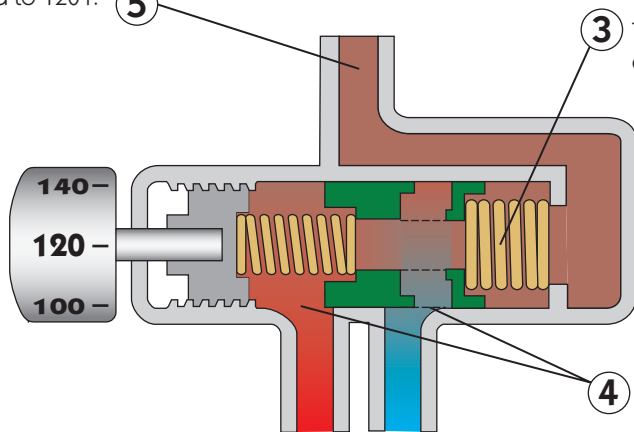

How It Works

A tempering valve maintains a constant water temperature at its outlet. It is most often found built into shower controls, under kitchen sinks, and after boiler tankless water heating coils.

Before Calling a Plumber

If the temperature of the water from the spout is less than that shown on the control knob, the temperature of the hot supply may be less than the setting.

If that is the case, increase the setting on the hot water source—the water heater.

② A clothes washer on the same supply line draws hot water, decreasing the pressure and flow of hot water, thereby decreasing the temperature in the mixing chamber.

③ The temperature-sense spring reacts to the colder temperature by contracting.

④ The contracted spring allows the sliding valve to move to the right, widening the hot port and narrowing the cold port.

Tub/Shower Control

Compression Type

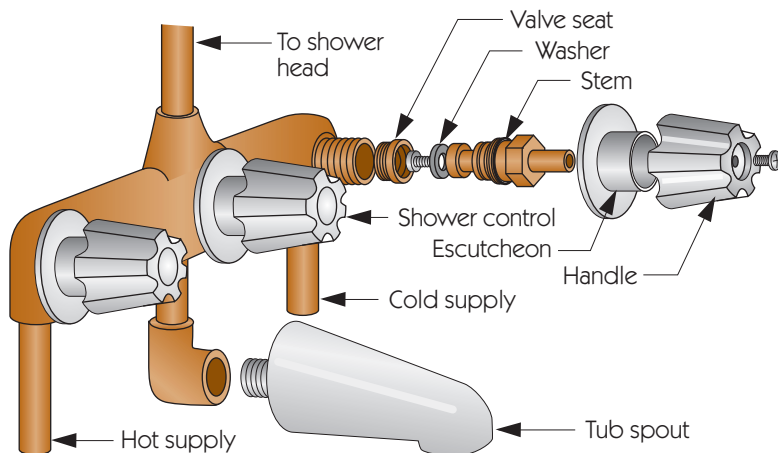

How It Works

Tub/shower controls are no different from sink faucets of the same type, with the exception of an additional diverter valve.

Compression-type controls (as on page 23) have separate valves for hot and cold supply, with the mixed temperature depending on both.

Disk-type controls (page 22) have a sliding and rotating disk, which alters the apertures of hot and cold inlets (temperature) and the aperture of the outlet (flow).

The diverter directs the outflow to either the tub spout or the shower head.

Disk Type

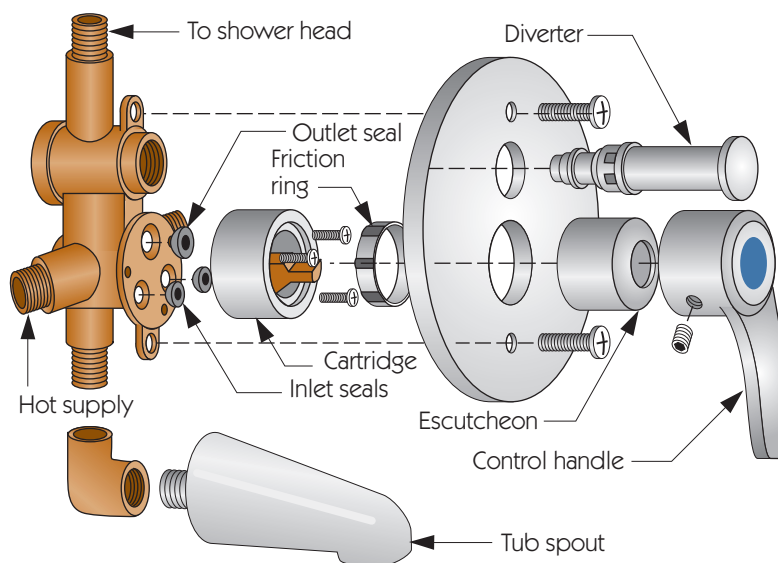

Before Calling a Plumber

If your tub/shower control has two or three handles, it utilizes compression valves. See page 23 for troubleshooting.

If the tub/shower control has a single handle, it likely contains a disk. In that case, see page 22 for further direction.

Freeze-Proof Sillcock

Neoprene washer forms a tight seal against the valve seat, stopping flow. **1**

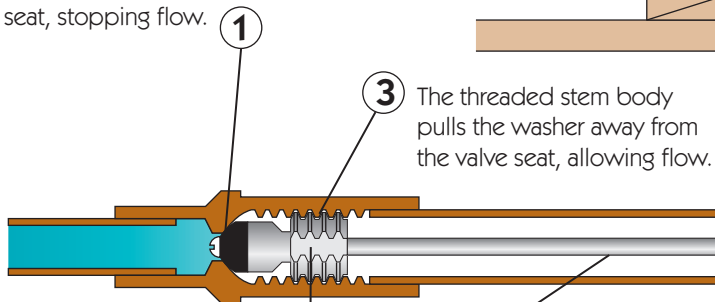

Grooves in the stem body allow water to pass. **4**

The extended stem keeps the water-filled portion of pipe within heated space, thus preventing freezing. **5**

The threaded stem body pulls the washer away from the valve seat, allowing flow. **3**

How They Work

Turning the handle counter-clockwise rotates the extended stem. **2**

Tightening the packing nut compresses the packing around the stem, preventing leakage under the handle. **6**

Common Sillcock

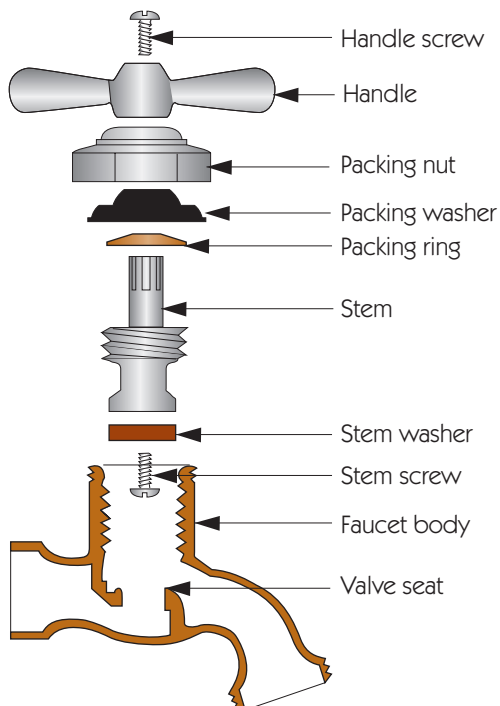

Before Calling a Plumber

If the sillcock continues to drip when firmly closed (turn handle clockwise to close), replace the washer.

If water drips from under the handle while the sillcock is open, tighten (turn clockwise) the packing nut under the handle. If no amount of tightening stops the dripping, remove both handle and packing nut, and replace the packing.

Pitcher (Hand) Pump

How It Works

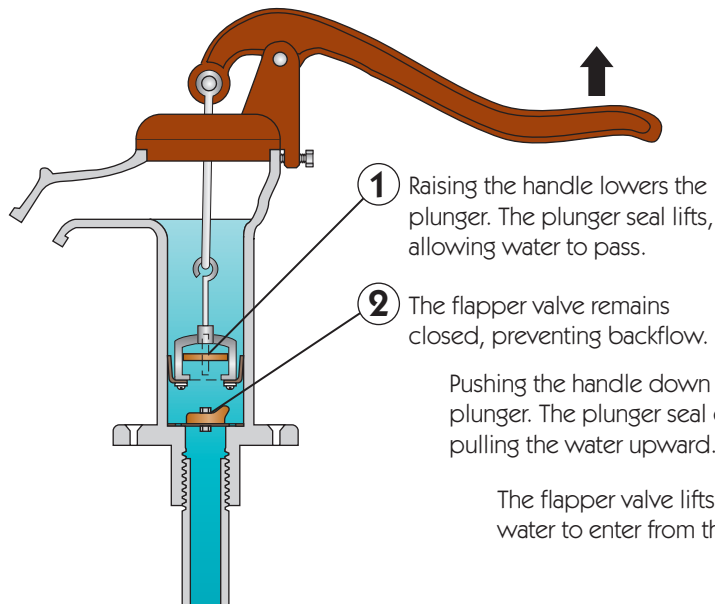

Pushing the handle down raises the plunger. The plunger seal drops, pulling the water upward.

The flapper valve lifts, allowing water to enter from the well.

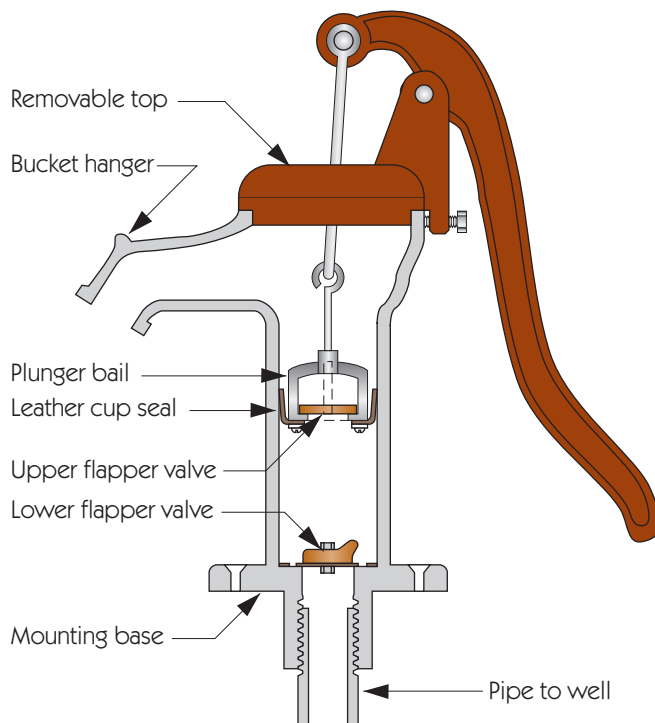
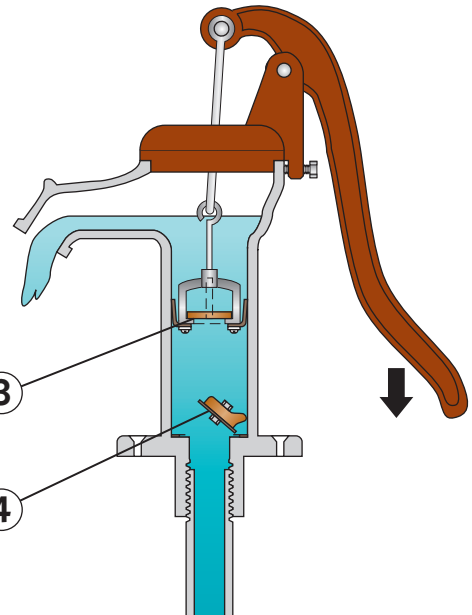

Before Calling a Plumber

The leather plunger and flapper valves tend to dry out if left unused. If pumping produces no water, prime the pump by pouring water into the top of the pump. Wetting the leather softens it, allowing the plunger and flapper valves to form better seals.

If repeated priming produces no results, or if you have to prime after less than an hour of disuse, replace both leather seals.

Soaking the leather in mineral oil before installation will slow the drying process.

Venturi Effect

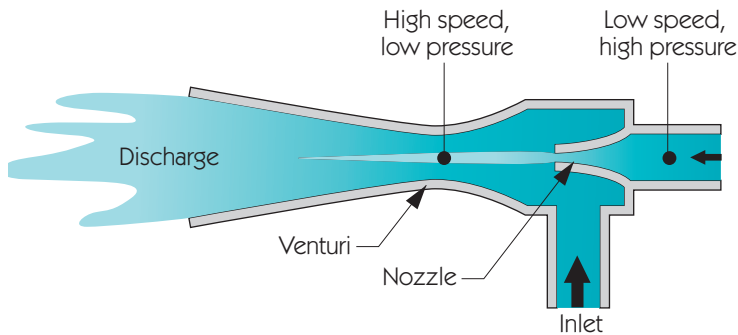

How It Works

The jet pump, used to pump water from a well, is based on the Venturi effect—a special application of Bernoulli's Principle. The principle states that the amount of energy in a fluid flow is constant. If the fluid speeds up, its kinetic energy increases, and its pressure (potential energy) necessarily decreases.

In the jet pump, water is forced through a nozzle, which increases its speed. The jet from the nozzle is an area of low pressure, which then entrains surrounding water flowing in from an inlet.

The flow out of the venturi is picked up by a rotating impeller, which further increases the pressure and flow. Some of the water from the impeller is discharged, but a portion is returned to the nozzle under pressure, thus continuing the process.

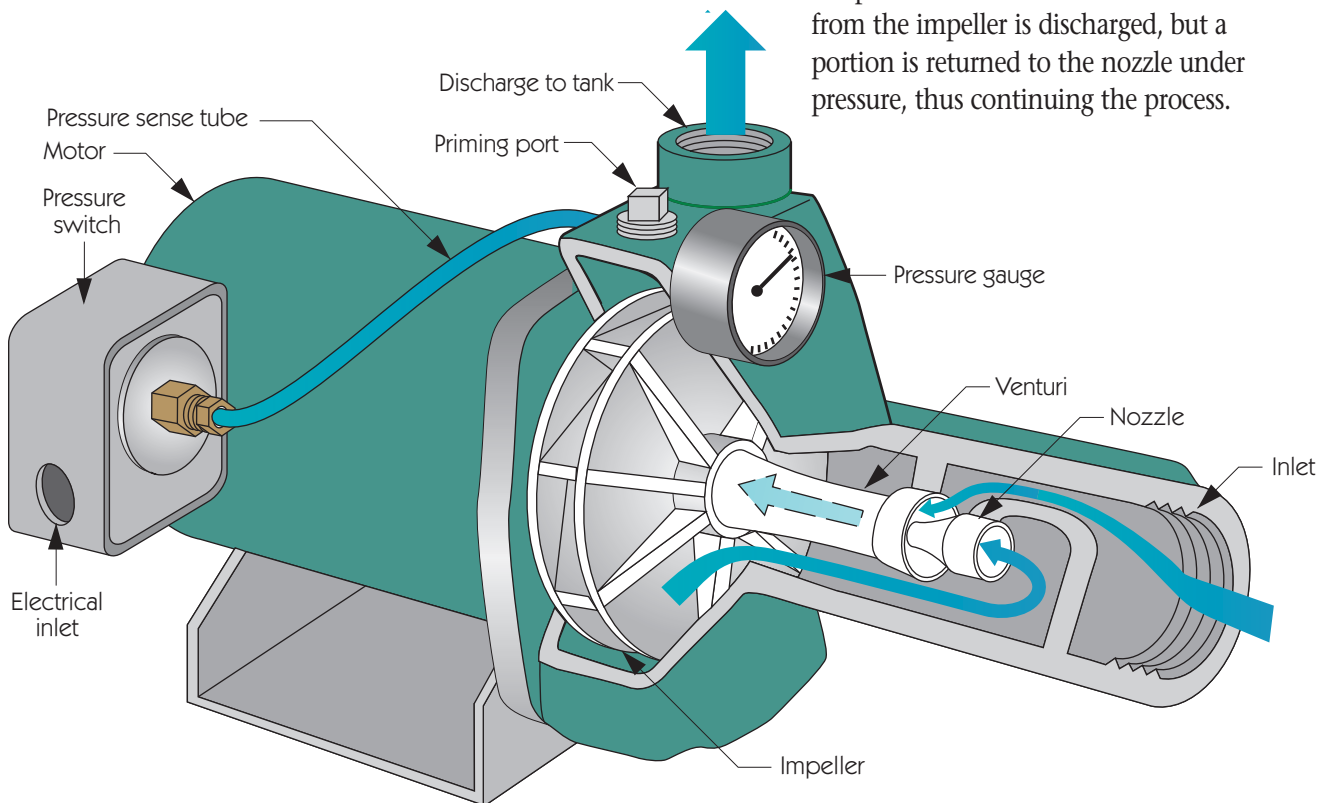

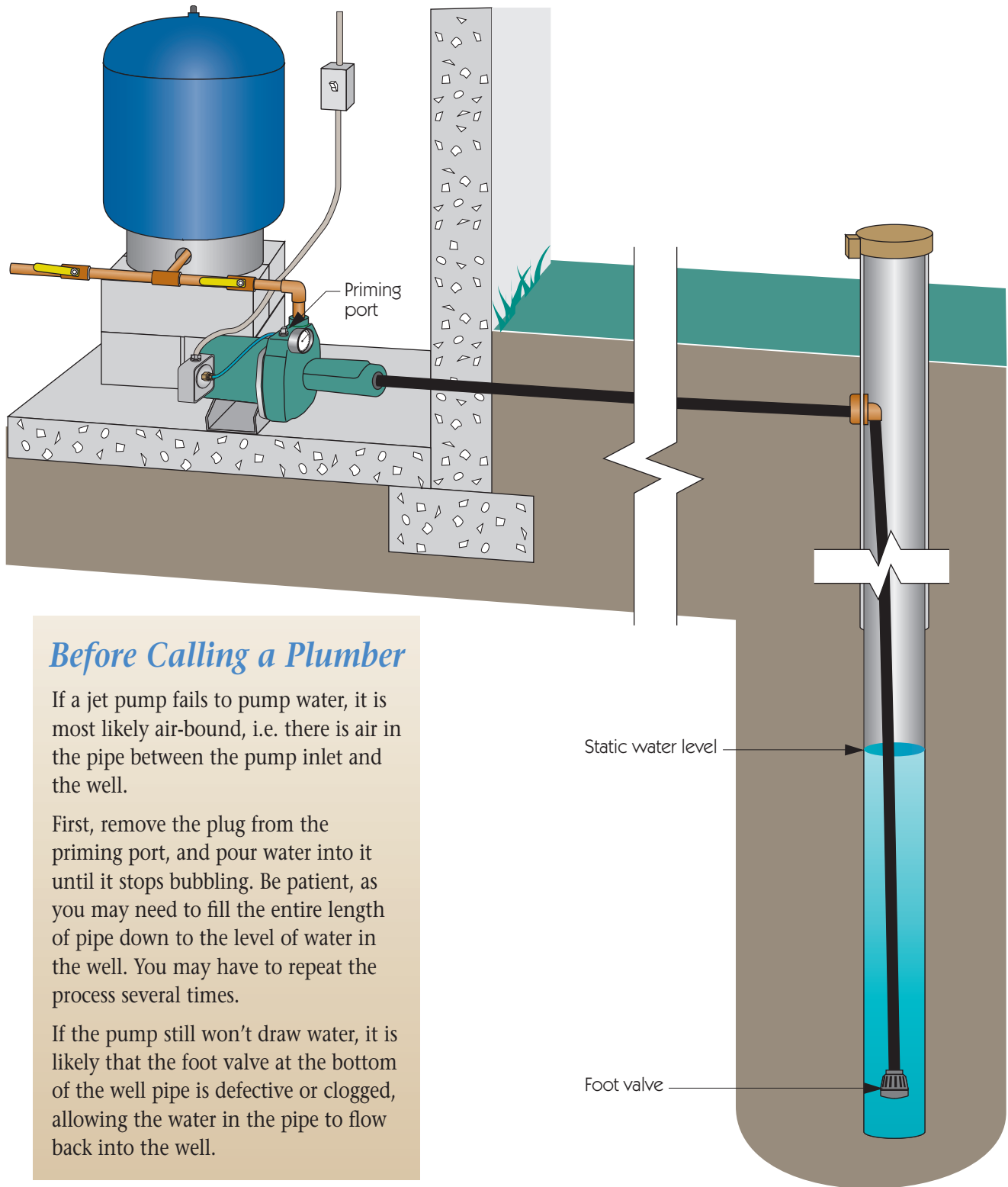

Before Calling a Plumber

If a jet pump fails to pump water, it is most likely air-bound, i.e. there is air in the pipe between the pump inlet and the well.

First, remove the plug from the priming port, and pour water into it until it stops bubbling. Be patient, as you may need to fill the entire length of pipe down to the level of water in the well. You may have to repeat the process several times.

If the pump still won't draw water, it is likely that the foot valve at the bottom of the well pipe is defective or clogged, allowing the water in the pipe to flow back into the well.

Submersible Pump

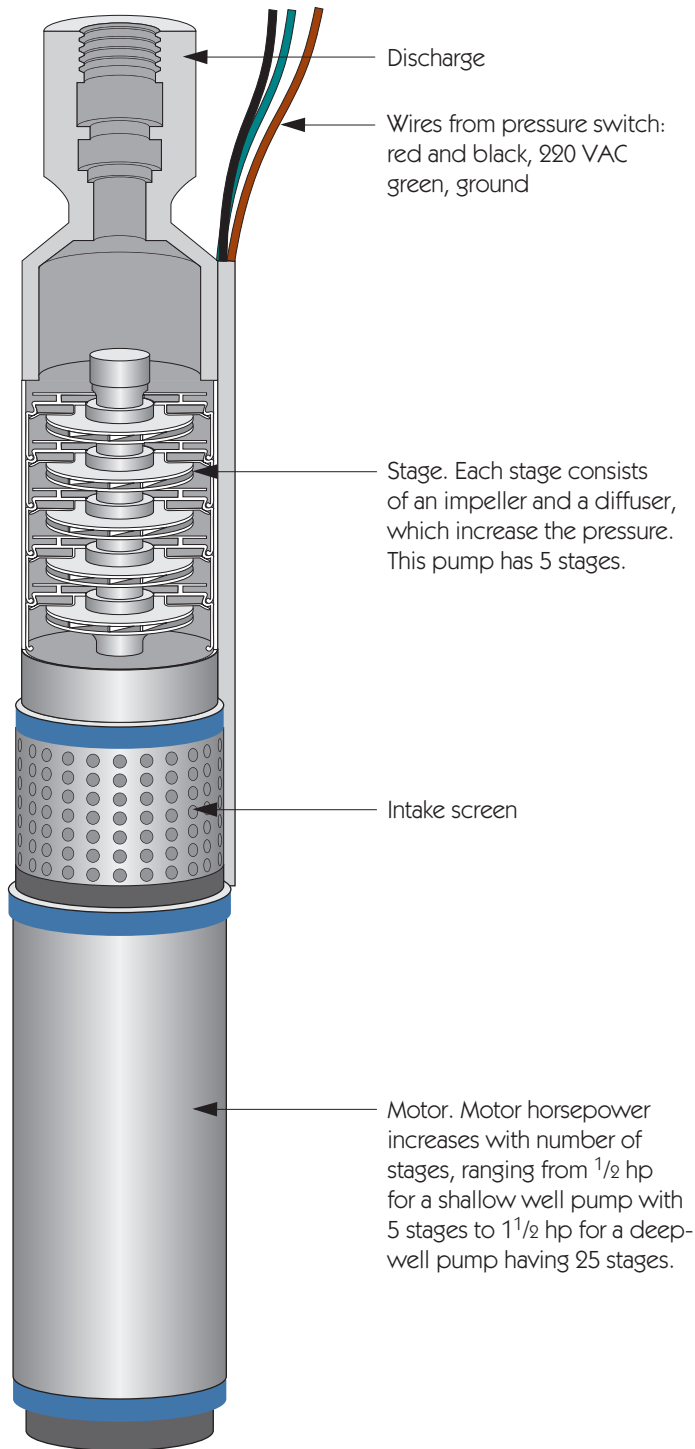

How It Works

The submersible pump is an elegant solution to the problem of lifting water from deep-drilled wells. The 4" diameter of residential-well models allow them to be lowered to the bottom of 6"-diameter wells. Since they push from below, rather than suck from above, these pumps can pump water from as deep as 1,000'. Since they are fully immersed in water, they never require priming and rarely overheat.

Water enters the pump through the intake screen, which filters out large particulates that could damage the pump.

The water is then picked up by the first stage. Each stage consists of a centrifugal impeller and a diffuser. The impeller creates about 15 psi of upward pressure, while the diffuser brakes the water's rotation. Each stage is driven by the same motor and shaft and adds 15 psi to the total pressure. Thus, a 5-stage pump can produce about 75 psi; a 20-stage pump, 300 psi.

In a shallow well, the pump may be suspended only by the 1" polyethylene pipe leading to the pitless adapter near the top of the well. Pumps in deep wells are supported by ropes to take the strain off the pipe's slip fittings.

The pitless adapter is a 2-piece coupling, which allows simple removal of the down-well assembly for repair or replacement.

The pressure switch at the storage tank supplies power to the sump in order to keep the tank pressure between 20 and 50 psi.

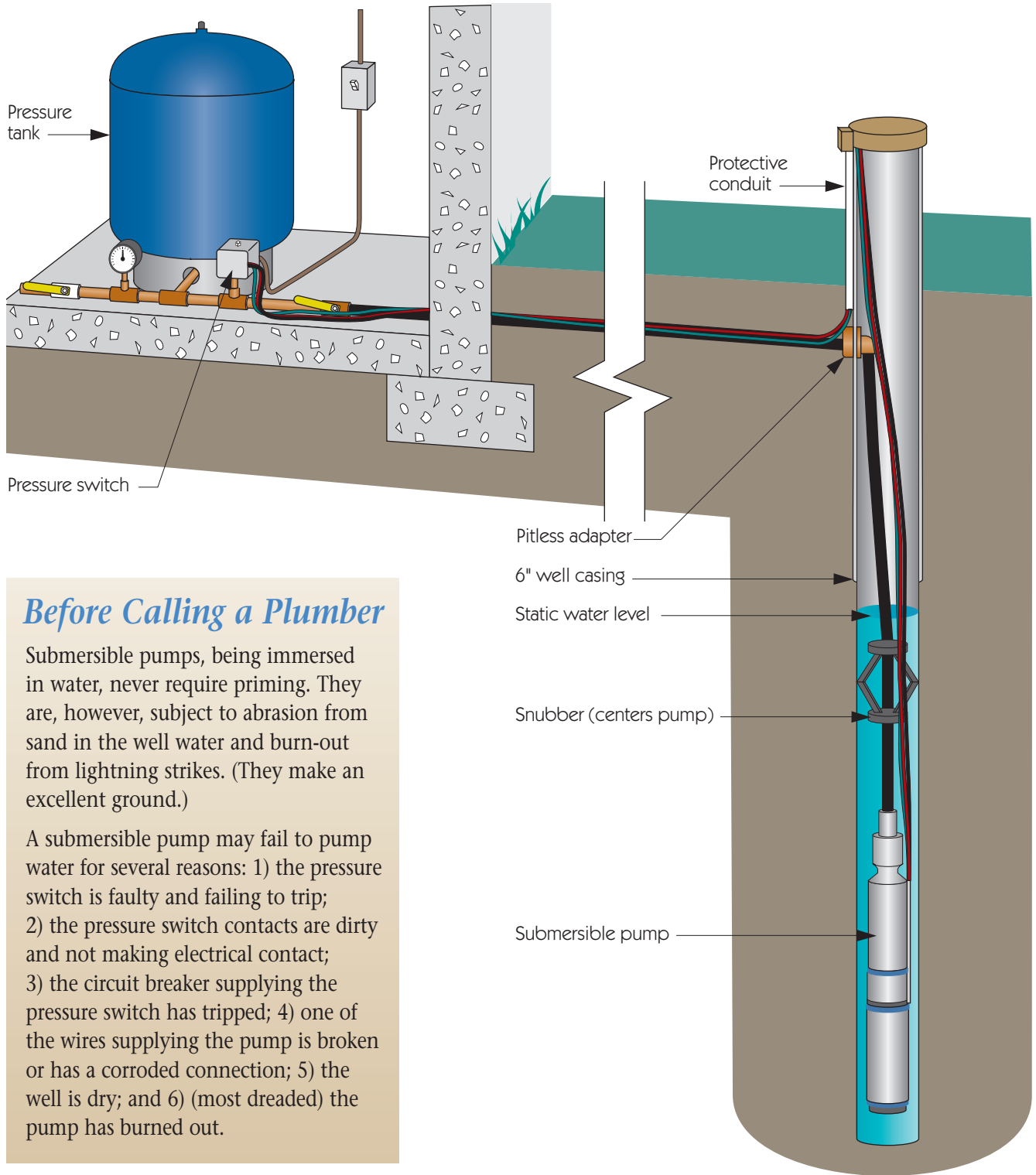

Before Calling a Plumber

Submersible pumps, being immersed in water, never require priming. They are, however, subject to abrasion from sand in the well water and burn-out from lightning strikes. (They make an excellent ground.)

A submersible pump may fail to pump water for several reasons: 1) the pressure switch is faulty and failing to trip; 2) the pressure switch contacts are dirty and not making electrical contact; 3) the circuit breaker supplying the pressure switch has tripped; 4) one of the wires supplying the pump is broken or has a corroded connection; 5) the well is dry; and 6) (most dreaded) the pump has burned out.

Sump Pump

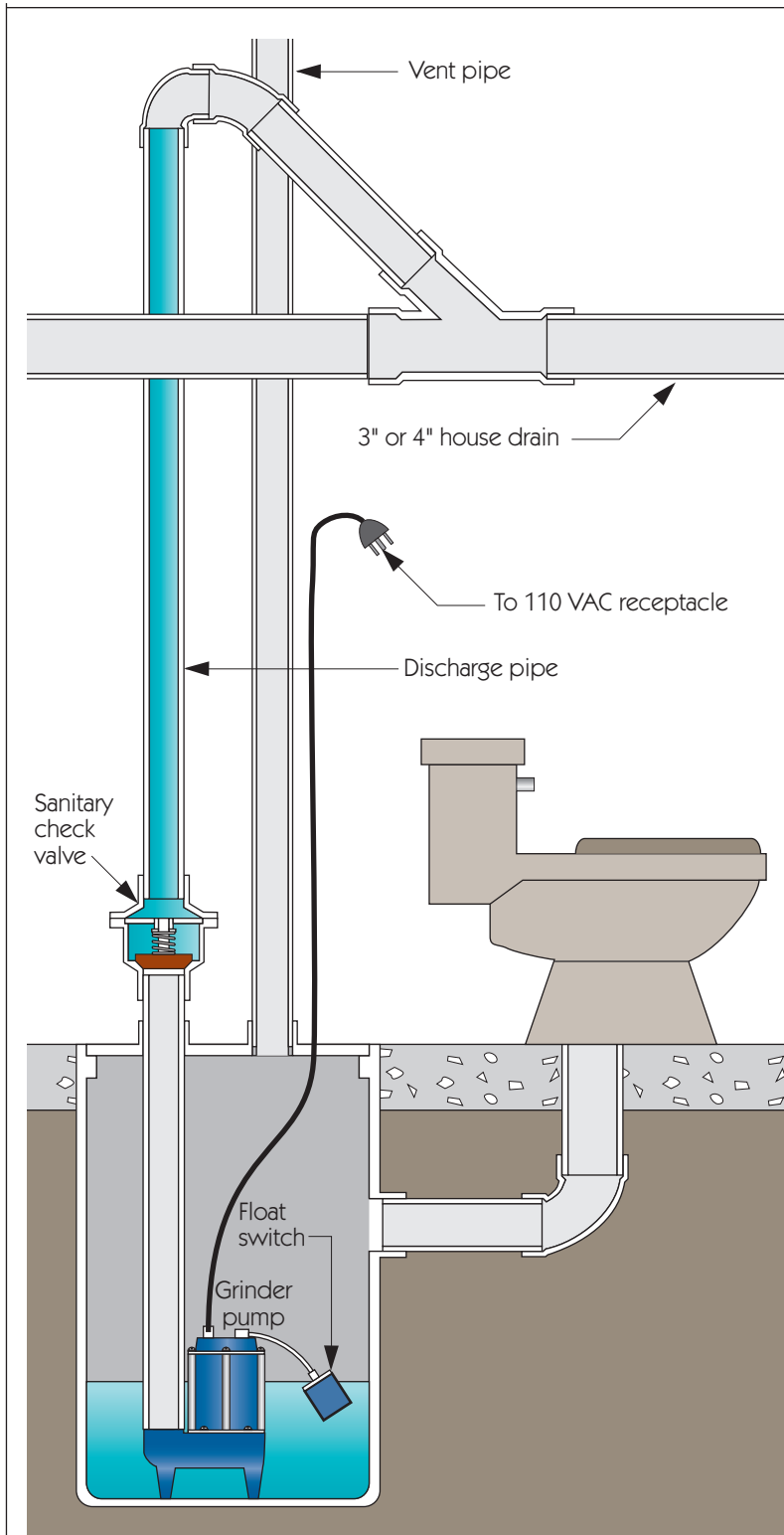

How It Works

House sewer drains usually exit the home above the basement floor level. This poses a dilemma when finishing a basement and adding a toilet. A sewage sump pump can provide the solution.

The toilet discharges into a plastic sump pit, containing the sewage sump pump. When the mixed solid and liquid waste rises, the float switch turns on the pump, which grinds the waste and ejects it upward through the discharge pipe and into the house drain.

A loop in the discharge pipe and a sanitary check valve prevent back-siphonage of waste from the house drain.

Before Calling a Plumber

Three things can cause a sump pump to stop working:

- 1) The pump may have stalled, drawing higher current and causing the circuit breaker to trip.
- 2) An object too tough for the pump to shred may have passed through the toilet and jammed the pump.
- 3) The pump motor or float switch may have burned out, requiring replacement.

Pressure Tank

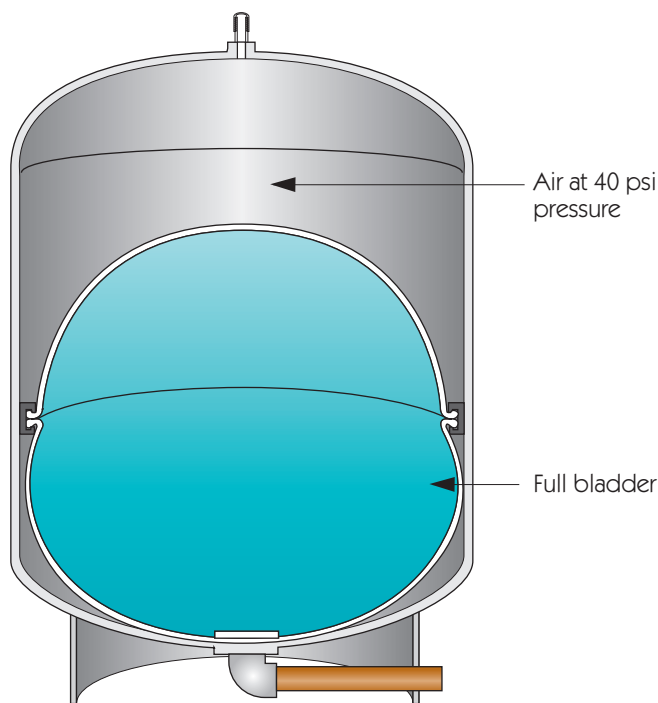
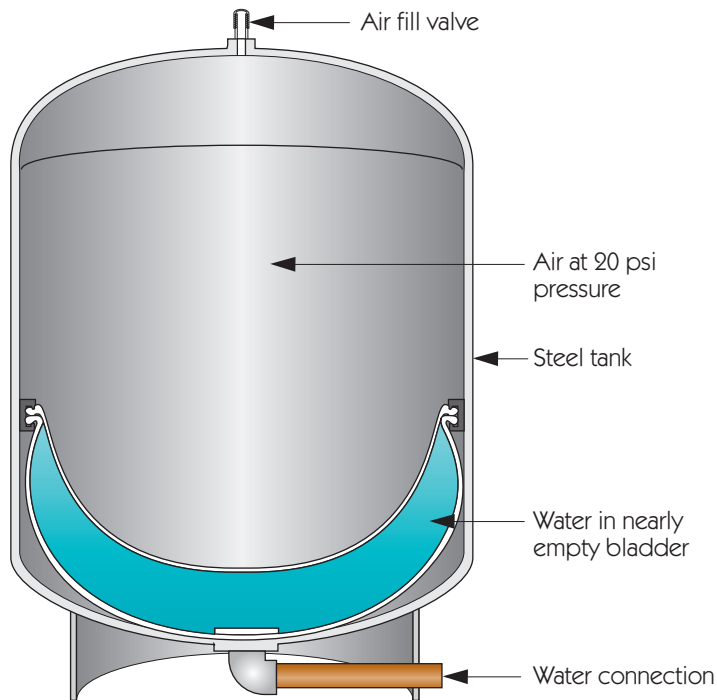

How It Works

In a private water supply, the pressure tank stores water under pressure so that the pump doesn't have to run every time a small amount of water is drawn.

Older tanks were simple vessels in which water entering from the bottom displaced and compressed the air in the tank to create pressure. A problem with this simple system was that, over time, the water absorbed the air, leaving little cushion. Eventually there was so little cushion that the pump cycled on and off every few seconds, leading to a premature failure.

Newer tanks contain the water in a vinyl or neoprene bladder. The air in the tank is separate from, and cannot be absorbed by, the water. In addition, the tank can be pressurized through an automotive-type fill valve at the top. By pre-pressurizing the tank to 20 psi and setting the pump's pressure switch to 20–40 psi, the volume per pump cycle can be maximized at roughly half the volume of the tank.

Before Calling a Plumber

If your pump turns on before the tank is nearly empty, turn off the pump, let the tank run dry, and pressurize the tank to 20 psi using a bicycle pump.

If the pump is cycling every few seconds, either the bladder has failed, allowing the air to be absorbed, or you have an older-style tank. In either case, replacement is recommended.

Gas Water Heater

How It Works

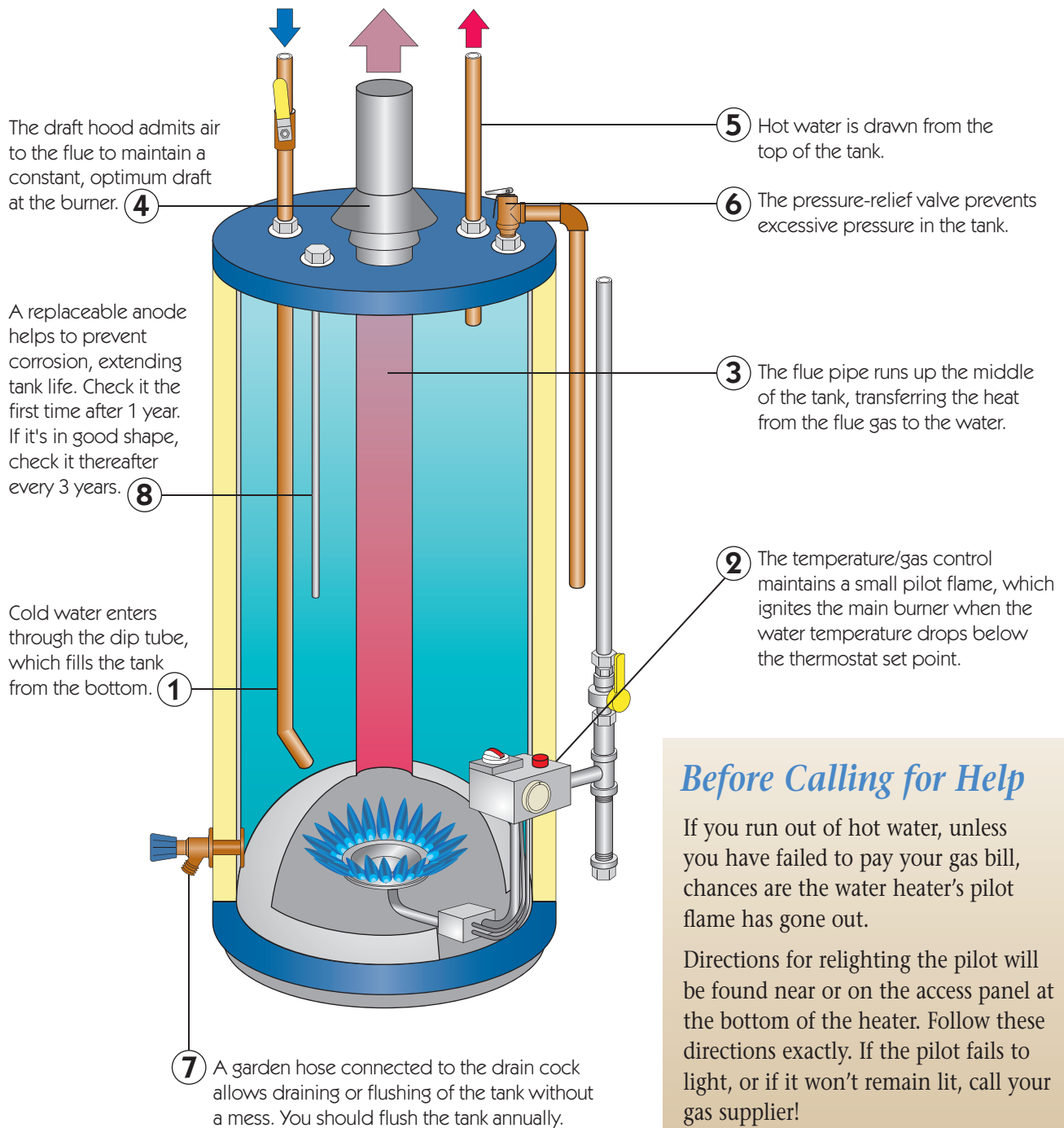

Before Calling for Help

If you run out of hot water, unless you have failed to pay your gas bill, chances are the water heater's pilot flame has gone out.

Directions for relighting the pilot will be found near or on the access panel at the bottom of the heater. Follow these directions exactly. If the pilot fails to light, or if it won't remain lit, call your gas supplier!

Gas Tankless Heater

How It Works

An outflow temperature monitor reports the hot water temperature to the computer, allowing it to regulate the gas flow. ⑤

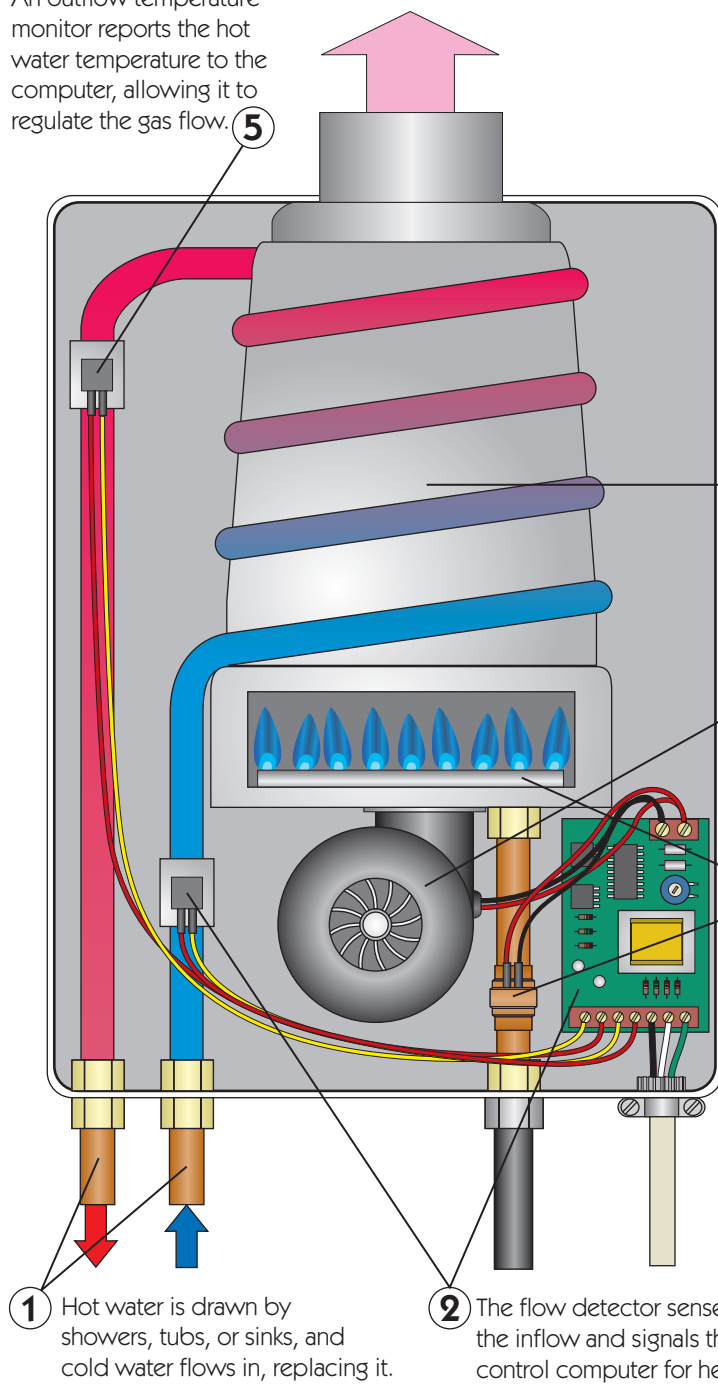

Between 10% and 20% of a water heater's energy use is standby loss—heat leaking out, 24 hours a day, while the heater is just storing hot water. The appeal of the heaters on these two pages is that there is no stored water, thus no standby loss.

To be considered, however, is the limited rate at which they can supply hot water. Read the manufacturer's specifications carefully, and compare them to your needs.

④ The heat exchanger transfers most of the heat of the flue gas to the water.

⑥ A small, computer-controlled fan provides a forced draft for optimum combustion and efficiency.

③ The computer turns on the gas and ignites the burner.

① Hot water is drawn by showers, tubs, or sinks, and cold water flows in, replacing it.

② The flow detector senses the inflow and signals the gas control computer for heat.

Electric Water Heater

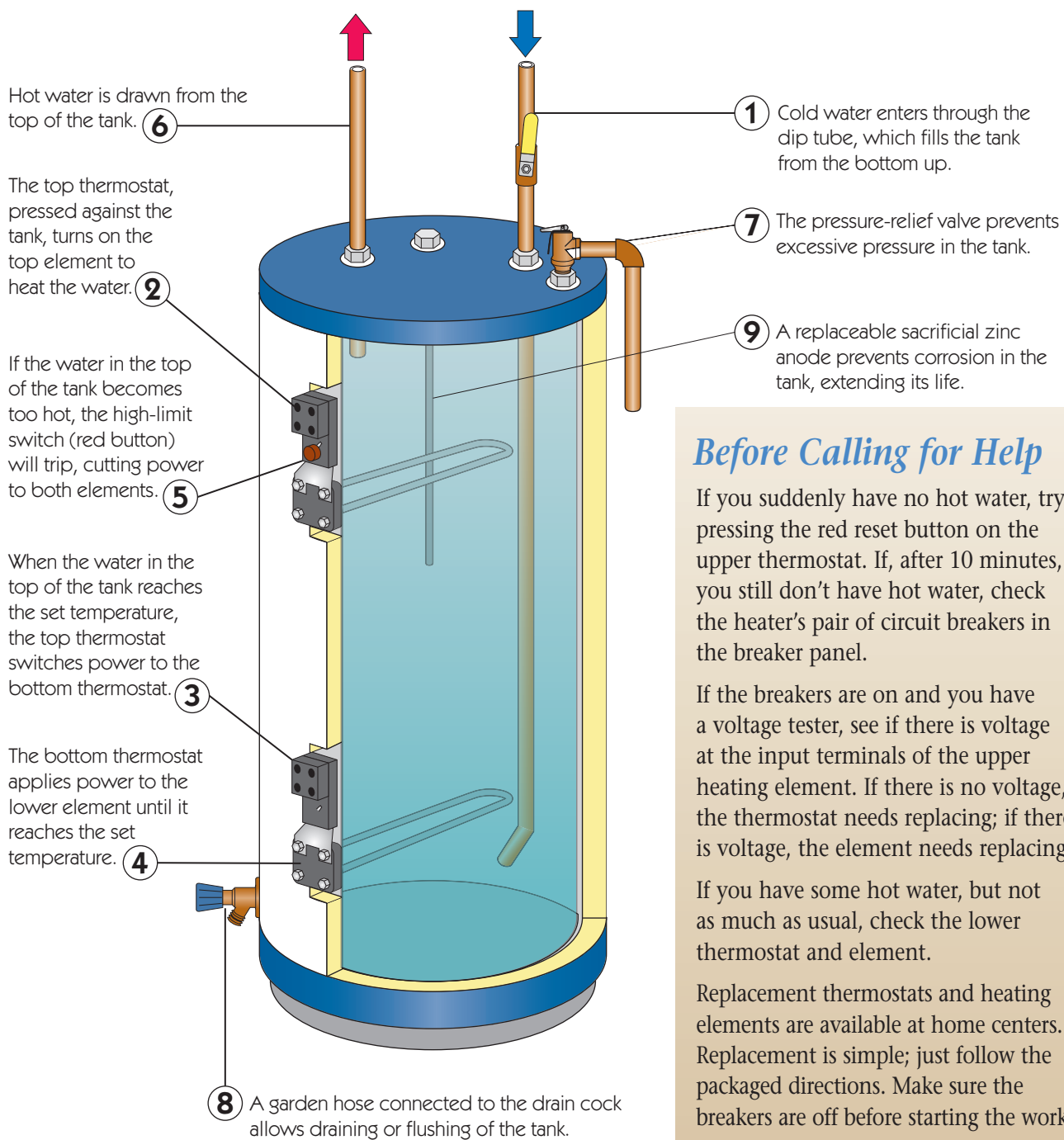
How It Works*Before Calling for Help*

If you suddenly have no hot water, try pressing the red reset button on the upper thermostat. If, after 10 minutes, you still don't have hot water, check the heater's pair of circuit breakers in the breaker panel.

If the breakers are on and you have a voltage tester, see if there is voltage at the input terminals of the upper heating element. If there is no voltage, the thermostat needs replacing; if there is voltage, the element needs replacing.

If you have some hot water, but not as much as usual, check the lower thermostat and element.

Replacement thermostats and heating elements are available at home centers. Replacement is simple; just follow the packaged directions. Make sure the breakers are off before starting the work.

Electric Tankless Heater

How It Works

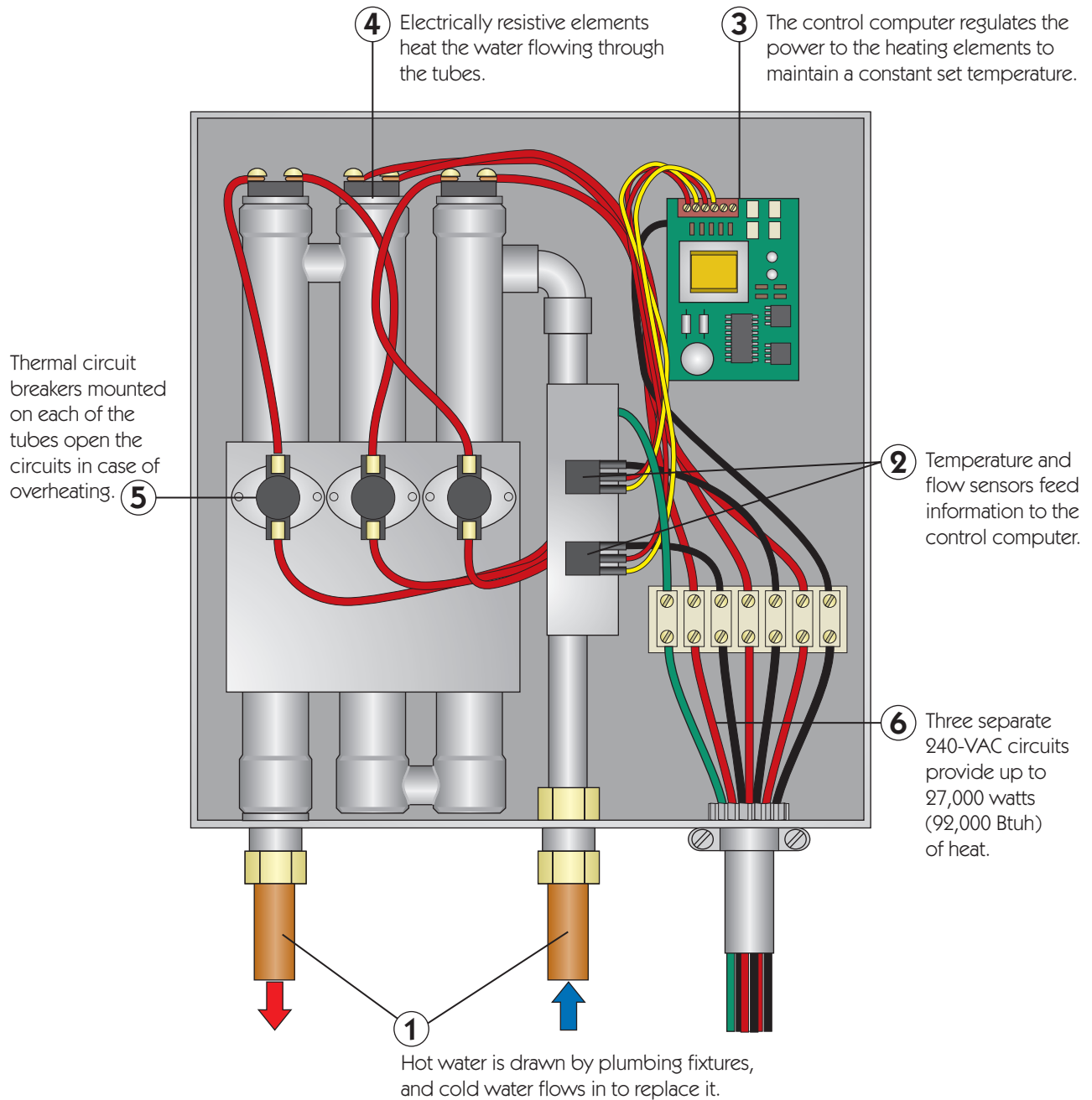

BoilerMate™ Water Heater

How It Works

Heating domestic hot water in a boiler with a tankless coil is inefficient during the off-heating season. Much of the heat is wasted through the boiler's limited insulation and up the vent flue.

The BoilerMate™ hot water storage tank reduces heat losses by half by requiring the boiler to fire only a couple of times a day and by being completely encased in thick insulation.

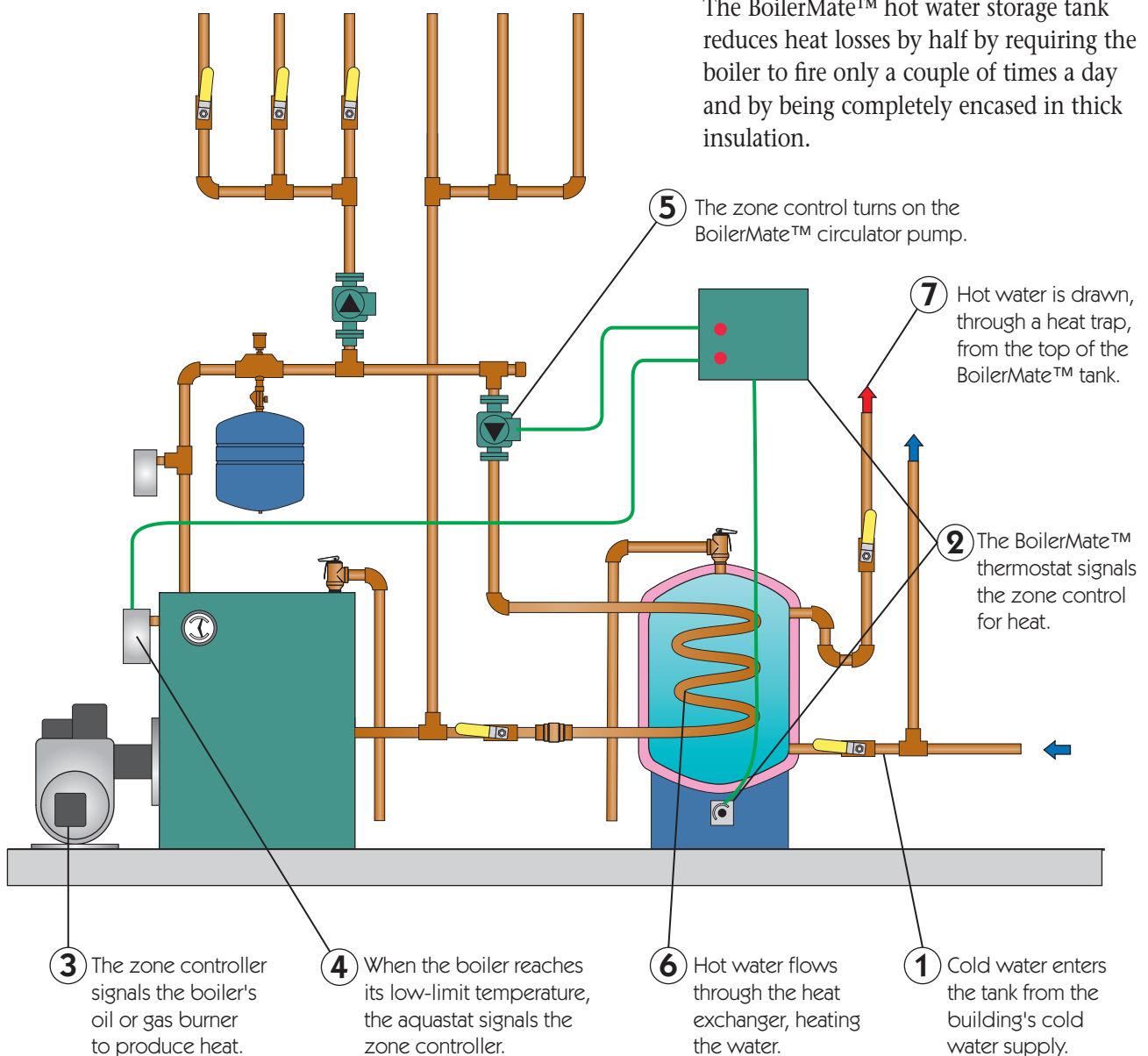

Heat Pump Water Heater

How It Works

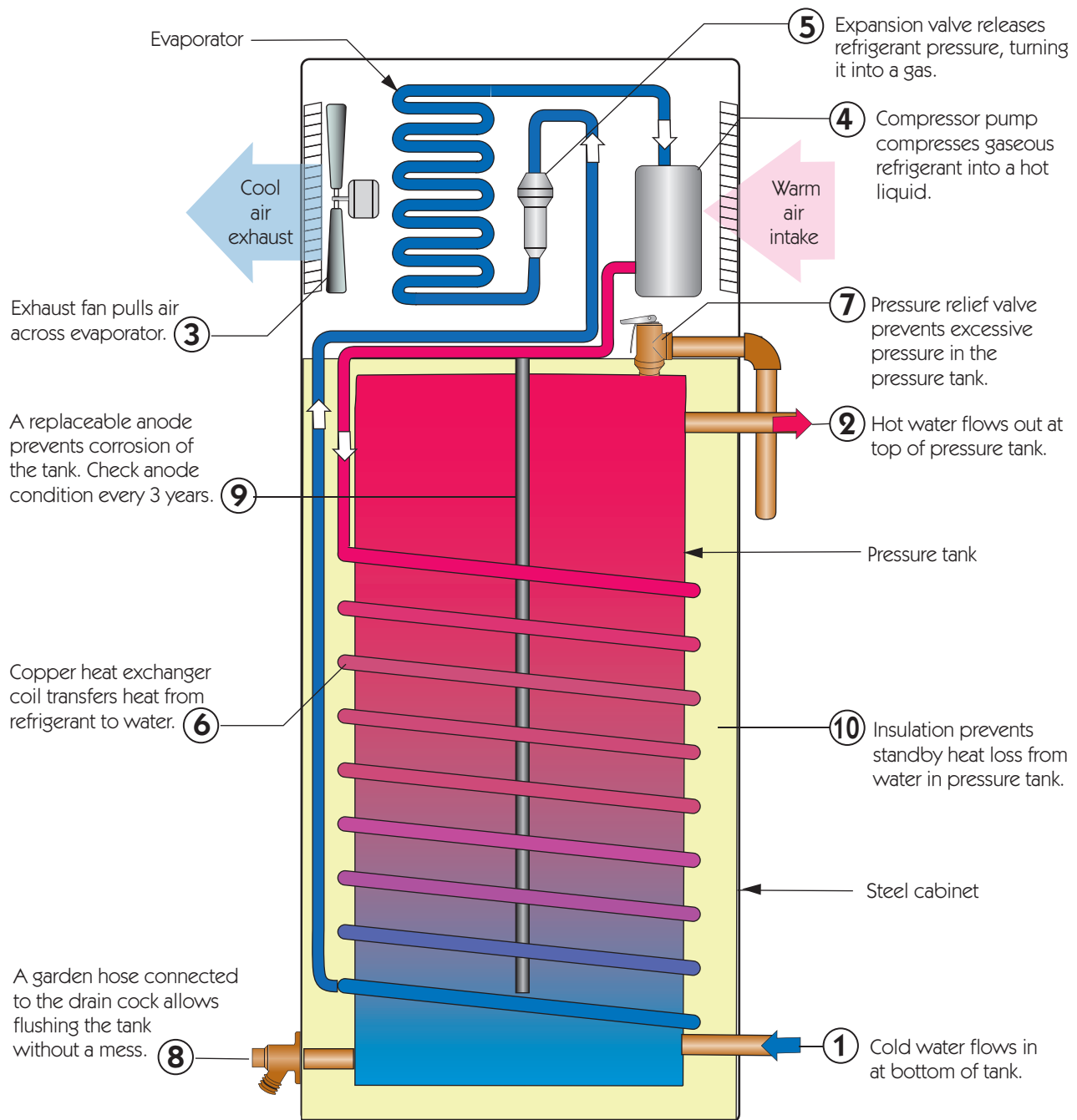

1

PLUMBING

Water Softener

How It Works

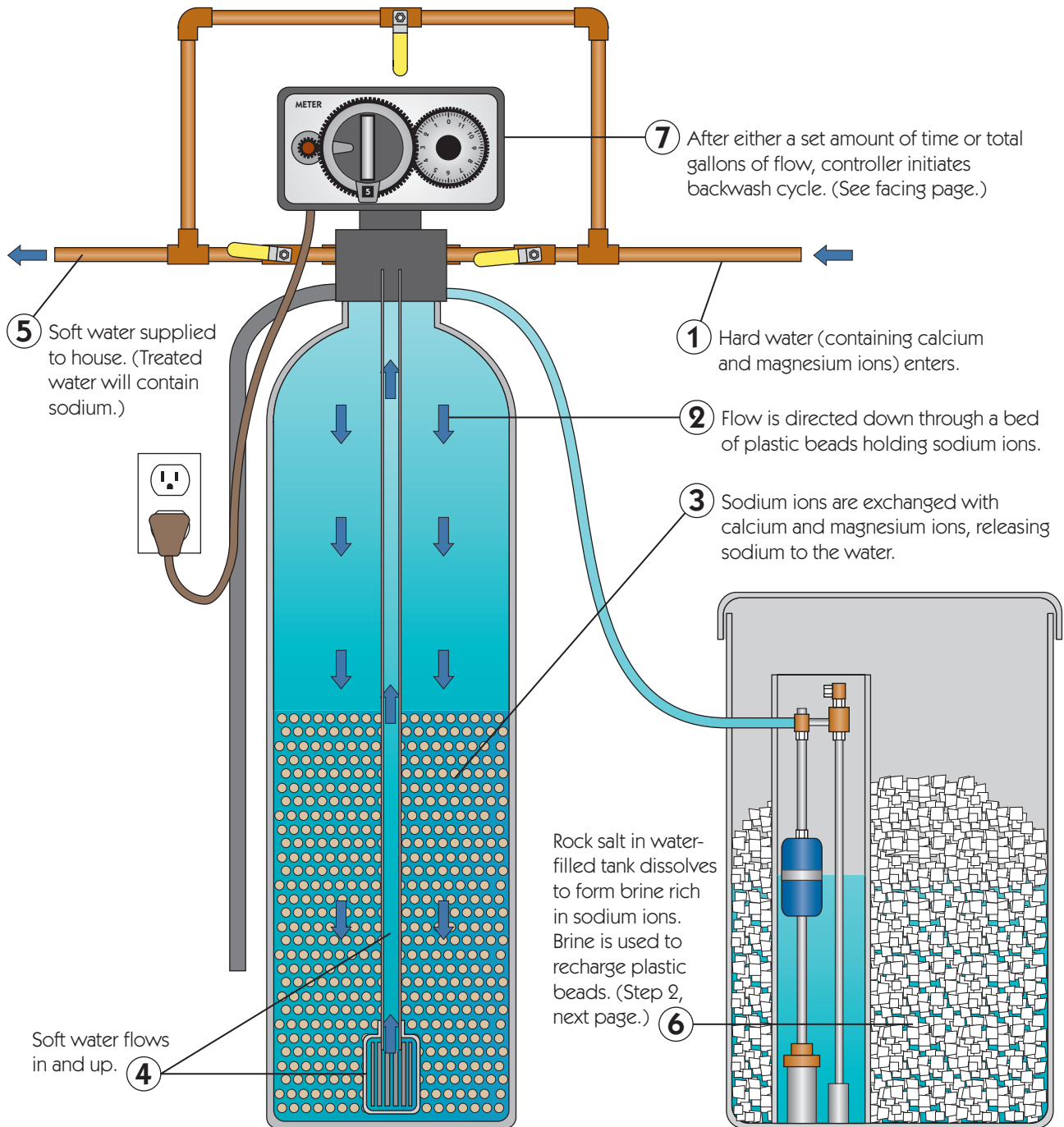

Recharging the Resin

①

Controller initiates backwash cycle. Untreated water flows in reverse direction through resin bed and is discharged into drain.

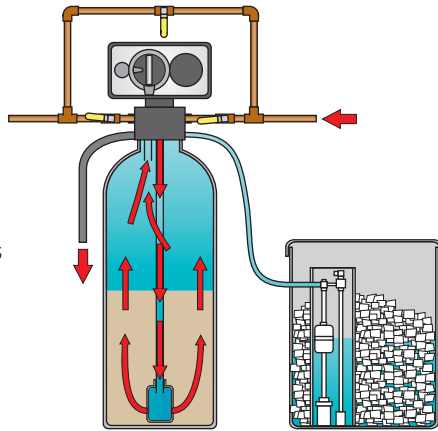

②

Controller switches to recharge cycle. Concentrated sodium solution (brine) pumped through resin bed forces replacement of calcium and magnesium ions by sodium ions. Altered solution is discharged into drain.

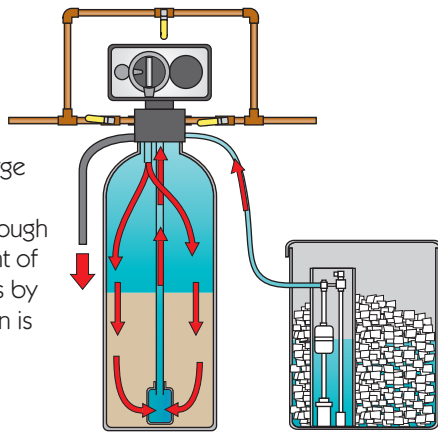

③

Resin bed is again rinsed with untreated water, but overflow this time refills brine tank with fresh water.

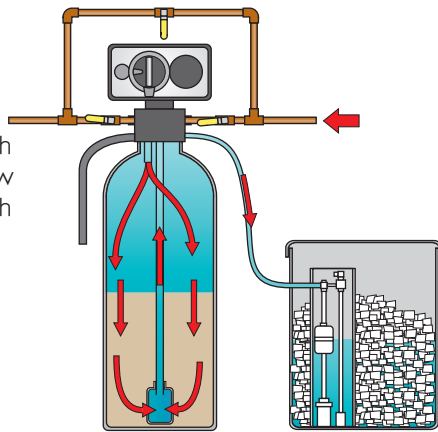

④

Rock salt in brine tank is slowly dissolved and must be manually replenished.

Before Calling a Plumber

If your water gradually turns hard again and never regains softness, check the brine tank. It may have run out of rock salt. (You can buy more at the hardware store.)

If there is plenty of salt left, check the water level in the brine tank. It should be about halfway up the tank. If not, add water directly to the tank.

If your water hardness cycles on a regular schedule, resin is becoming saturated, and the controller must be reset to recharge more often. See the operator's manual for instructions on resetting.

Charcoal Cartridge Filter

How It Works

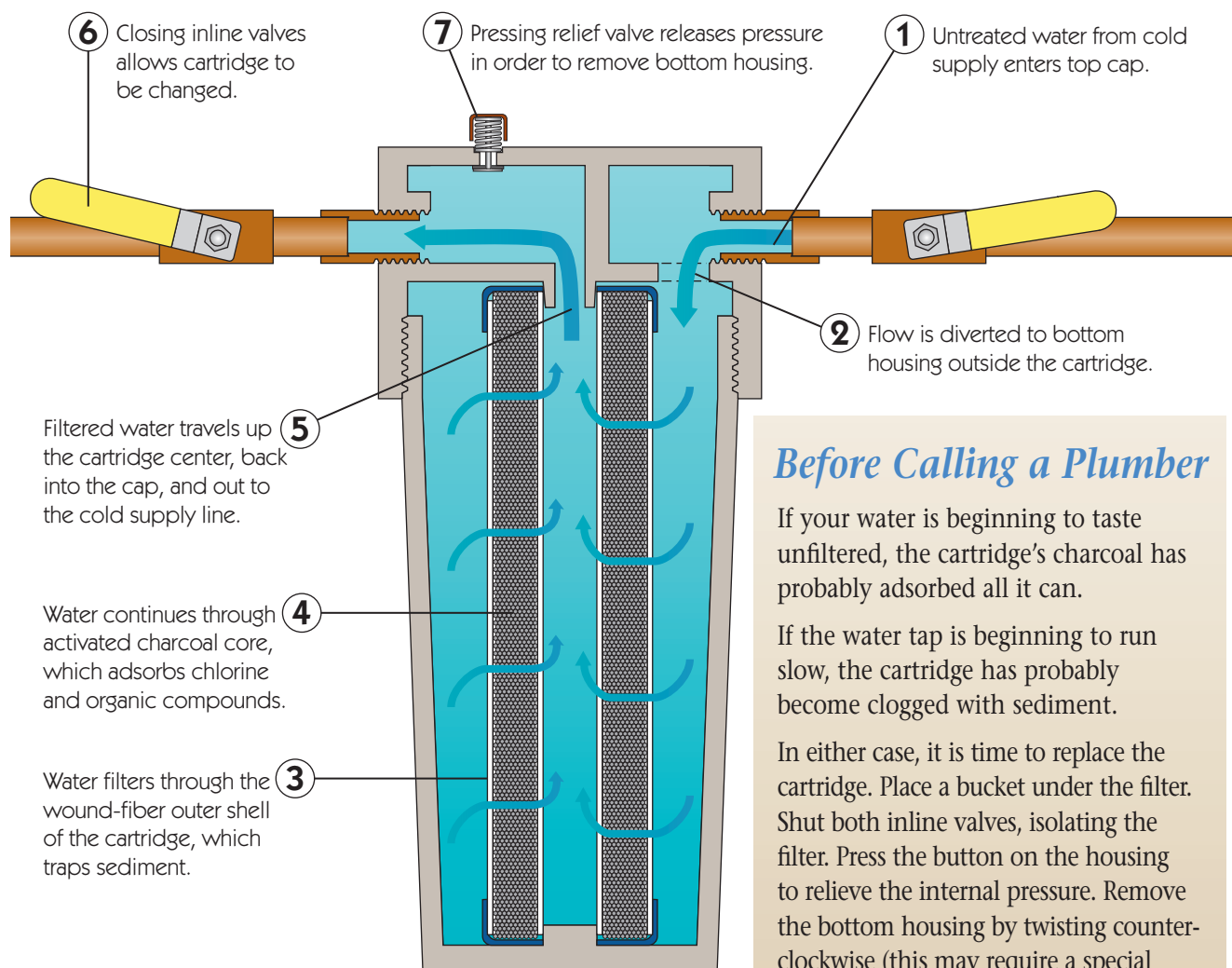

Before Calling a Plumber

If your water is beginning to taste unfiltered, the cartridge's charcoal has probably adsorbed all it can.

If the water tap is beginning to run slow, the cartridge has probably become clogged with sediment.

In either case, it is time to replace the cartridge. Place a bucket under the filter. Shut both inline valves, isolating the filter. Press the button on the housing to relieve the internal pressure. Remove the bottom housing by twisting counter-clockwise (this may require a special wrench), and lift out the old filter.

Wash out the housing, and insert a new cartridge and O-ring (first wiping O-ring with petroleum jelly). Replace the bottom housing by twisting clockwise until hand-tight.

Open the two inline valves, and run water at the tap until it runs clear with no bubbles.

Tank Filter

How It Works

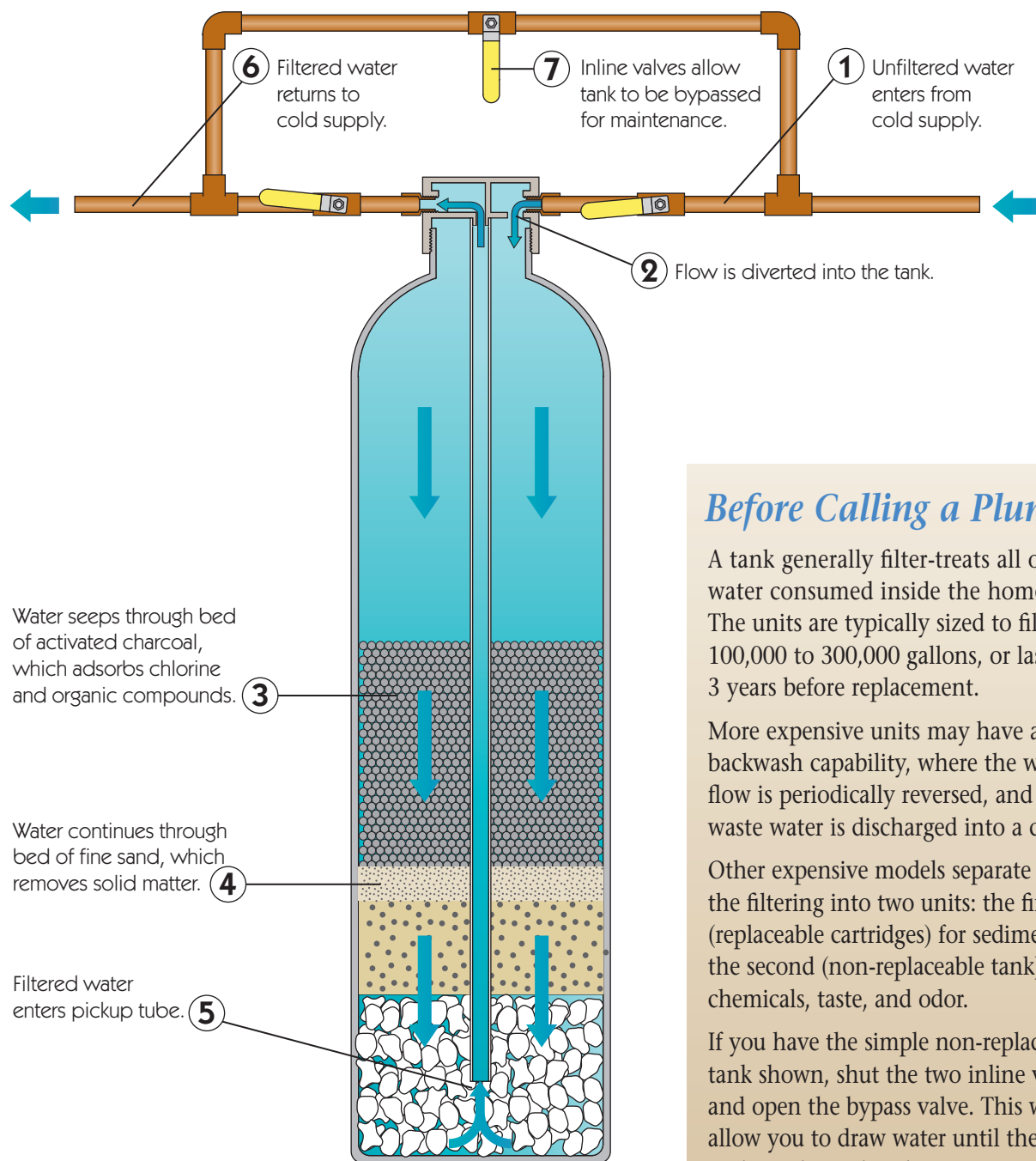

Before Calling a Plumber

A tank generally filter-treats all of the water consumed inside the home. The units are typically sized to filter 100,000 to 300,000 gallons, or last 1 to 3 years before replacement.

More expensive units may have a backwash capability, where the water flow is periodically reversed, and the waste water is discharged into a drain.

Other expensive models separate the filtering into two units: the first (replaceable cartridges) for sediment, the second (non-replaceable tank) for chemicals, taste, and odor.

If you have the simple non-replaceable tank shown, shut the two inline valves and open the bypass valve. This will allow you to draw water until the filter tank can be replaced.

Reverse Osmosis Filter

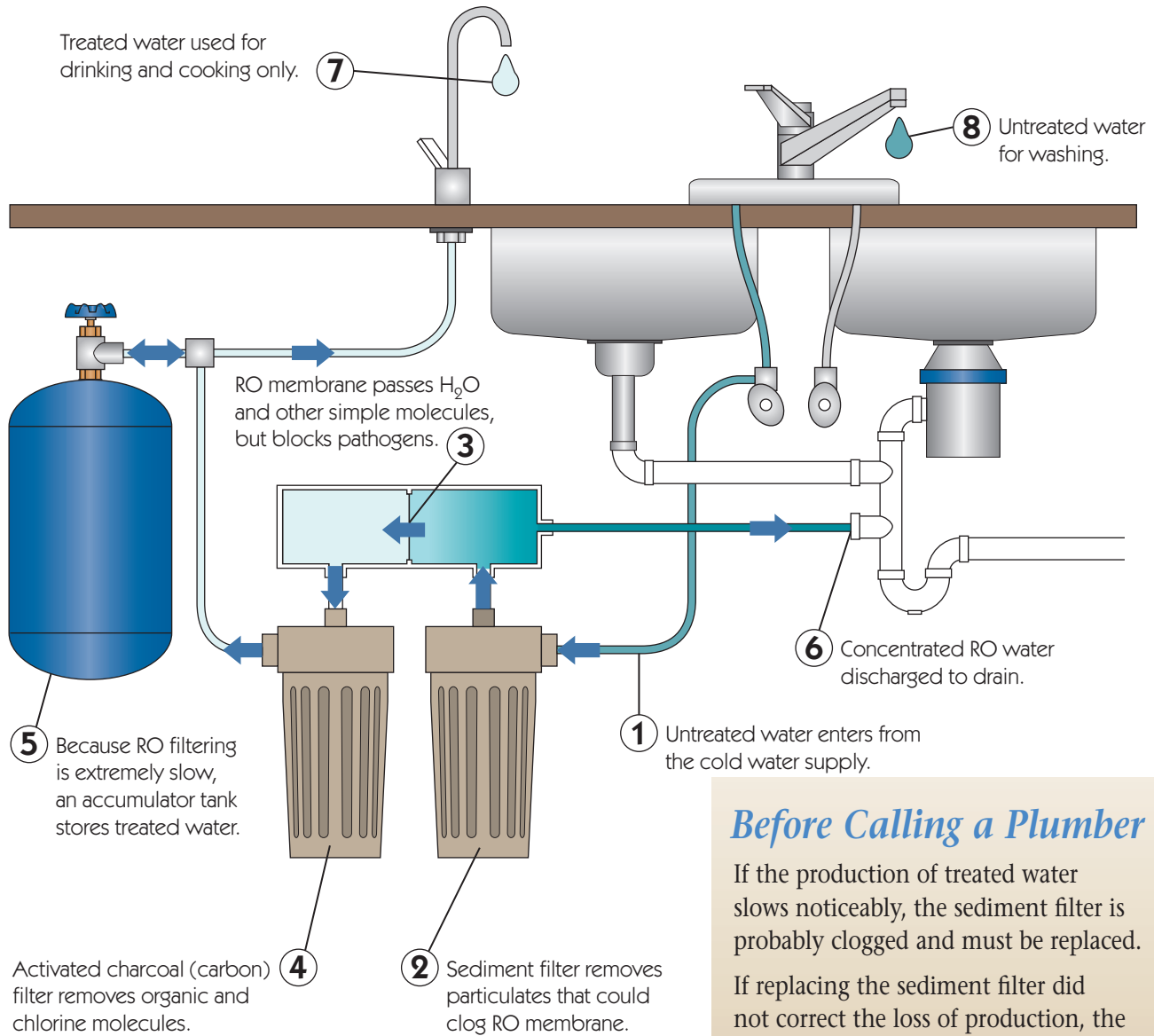
How It Works

Activated charcoal (carbon) filter removes organic and chlorine molecules. **4**

Sediment filter removes particulates that could clog RO membrane. **2**

Reverse osmosis (RO) filters combine three filtering components: a sediment filter to remove large particles, a plastic reverse-osmosis membrane to remove dissolved salts and metals, and an activated charcoal canister to remove tastes and odors. No home system provides a greater degree of filtering.

Before Calling a Plumber

If the production of treated water slows noticeably, the sediment filter is probably clogged and must be replaced.

If replacing the sediment filter did not correct the loss of production, the RO filter may be fouled and require cleaning or replacement. Refer to your owner's manual.

If the water begins to taste or smell of chemicals, the charcoal filter may be used up and require replacement.

UV Purifier

How It Works

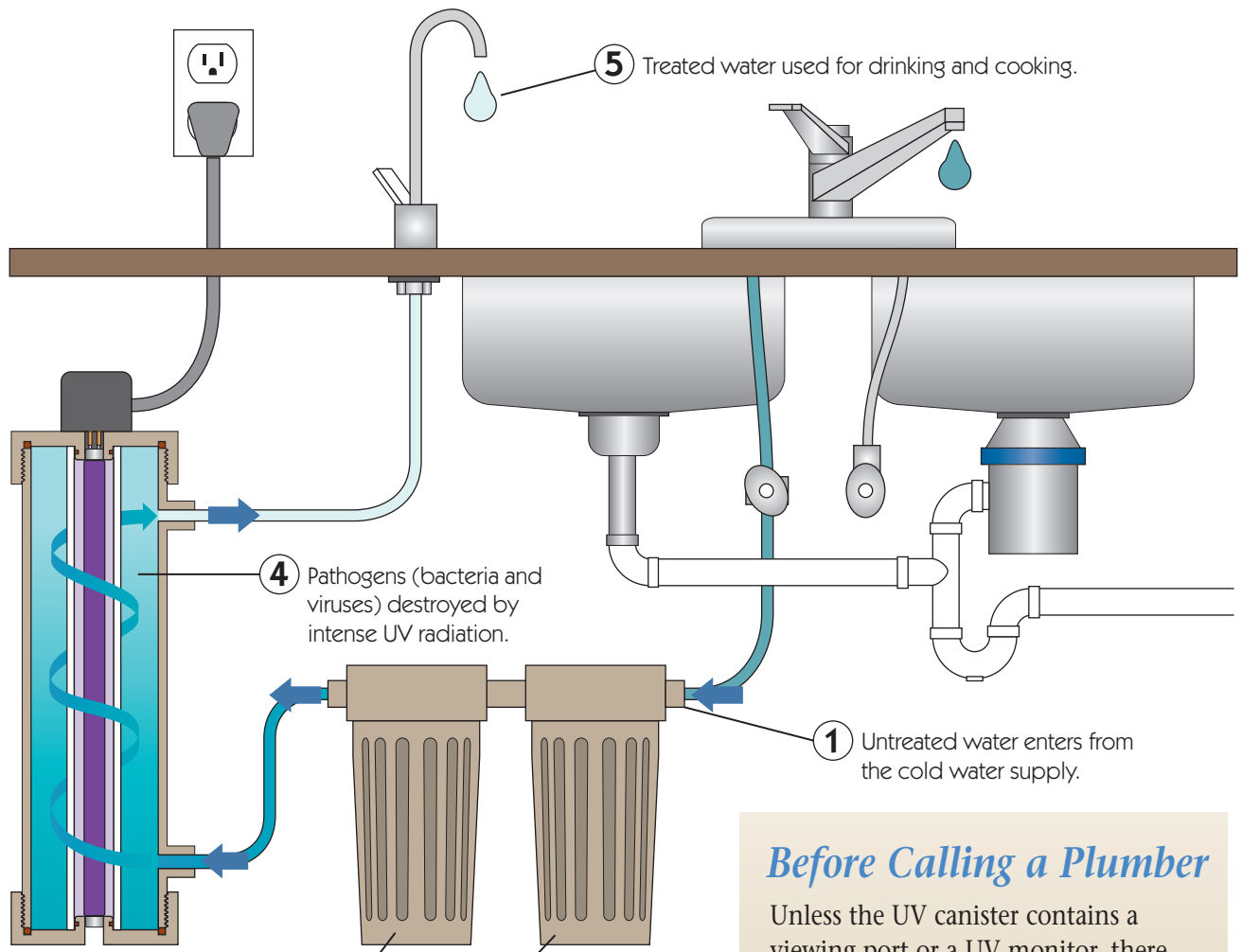

Activated charcoal (carbon) **3** filter removes organic and chlorine molecules.

2 Sediment filter removes particulates that cloud the water and reduce the penetration of the UV rays.

Ultraviolet filter systems generally include a sediment filter and an activated charcoal filter, in addition to the UV canister, to remove large particles, taste, and odor. The unique feature of the UV filter is the ability to destroy bacteria and viruses without requiring chlorination or boiling.

Before Calling a Plumber

Unless the UV canister contains a viewing port or a UV monitor, there is no way to tell if the UV lamp is working. To make sure it is, replace the bulb annually.

If the production of treated water slows noticeably, the sediment filter is probably clogged and must be replaced.

If the water begins to taste or smell of chemicals, the charcoal filter may be used up and require replacement.

Fire Sprinkler

A plug, held in place by a glycerine-filled ampule, seals the sprinkler outlet. **1**

As the ampule heats up, the glycerine expands. Within a minute or two of reaching 155°F, the pressure shatters the glass ampule, releasing the plug. **2**

Water under pressure strikes the deflector plate and sprays radially over a large area. The cooling effect usually prevents other sprinkler heads from activating. **3**

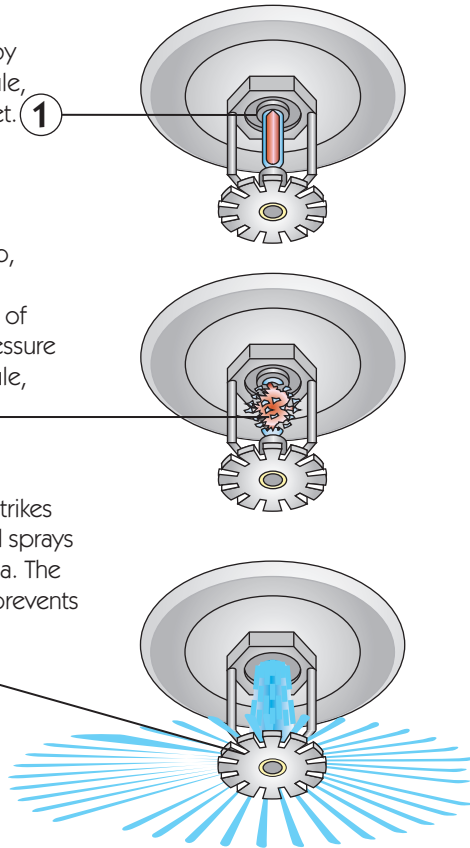

How It Works

An unvented fire in an enclosed space produces heated air, which, because warm air is buoyant, rises to the ceiling. The air temperature at ceiling level steadily increases until it reaches the design temperature of the sprinkler head. This temperature, about 150°F, is well below the danger point for human respiration and the ignition points of furnishings and construction materials.

As soon as the closest sprinkler triggers, water striking the fire evaporates, absorbing its latent heat of evaporation and cooling the air and burning material. (Recall the cooling effect of a rain shower on a hot day.) Deprived of heat, the fire is usually extinguished.

Unfortunately, the sprinkler continues to spray until someone turns it off!

Typical Distribution of Sprinkler Heads

