

1

THE BUILDING SITE

- 1.02 Building in Context
- 1.03 Sustainability
- 1.04 Green Building
- 1.05 Green Building Standards
- 1.11 Resilient Design
- 1.12 The 2030 Challenge
- 1.13 Site Analysis
- 1.14 Soils
- 1.15 Soil Mechanics
- 1.16 Topography
- 1.18 Plant Materials
- 1.19 Trees
- 1.20 Solar Radiation
- 1.22 Passive Solar Design
- 1.24 Solar Shading
- 1.25 Daylighting
- 1.26 Precipitation
- 1.27 Site Drainage
- 1.28 Wind
- 1.29 Sound & Views
- 1.30 Regulatory Factors
- 1.31 Zoning Ordinances
- 1.32 Site Access & Circulation
- 1.33 Pedestrian Circulation
- 1.34 Vehicular Circulation
- 1.35 Vehicular Parking
- 1.36 Slope Protection
- 1.37 Retaining Walls
- 1.40 Paving
- 1.42 The Site Plan
- 1.44 Site Description

1.02 BUILDING IN CONTEXT

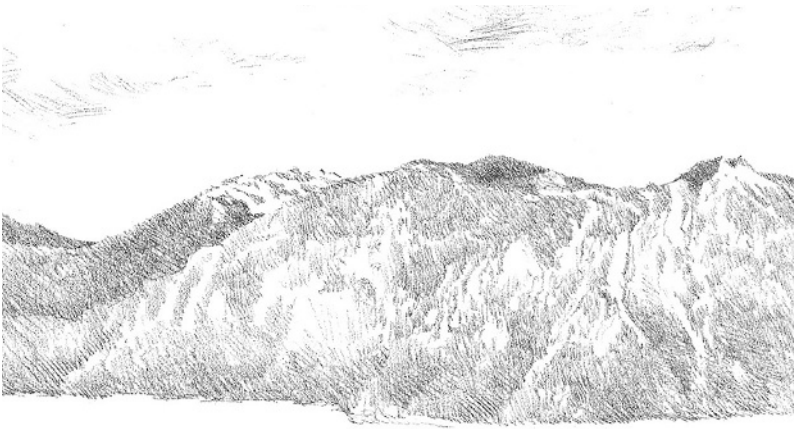

Buildings do not exist in isolation. They are conceived to house, support, and inspire a range of human activities in response to sociocultural, economic, and political needs, and are erected in natural and built environments that constrain as well as offer opportunities for development. We should, therefore, carefully consider the contextual forces that a site presents in planning the design and construction of buildings.

The microclimate, topography, and natural habitat of a site all influence design decisions at a very early stage in the design process. To enhance human comfort as well as conserve energy and material resources, responsive and sustainable design respects the indigenous qualities of a place, adapts the form and layout of a building to the landscape, and takes into account the path of the sun, the rush of the wind, and the flow of water on a site.

In addition to environmental forces, there exist the regulatory forces of zoning ordinances. These regulations take into account existing land use patterns and prescribe the acceptable uses and activities for a site as well as limit the size and shape of the building mass and where it may be located on the site.

Just as environmental and regulatory factors influence where and how development occurs, the construction, use, and maintenance of buildings inevitably place a demand on transportation systems, utilities, and other services. A fundamental question we face is how much development a site can sustain without exceeding the capacity of these service systems, consuming too much energy, or causing environmental damage.

Consideration of these contextual forces on site and building design cannot proceed without a brief discussion of sustainability.

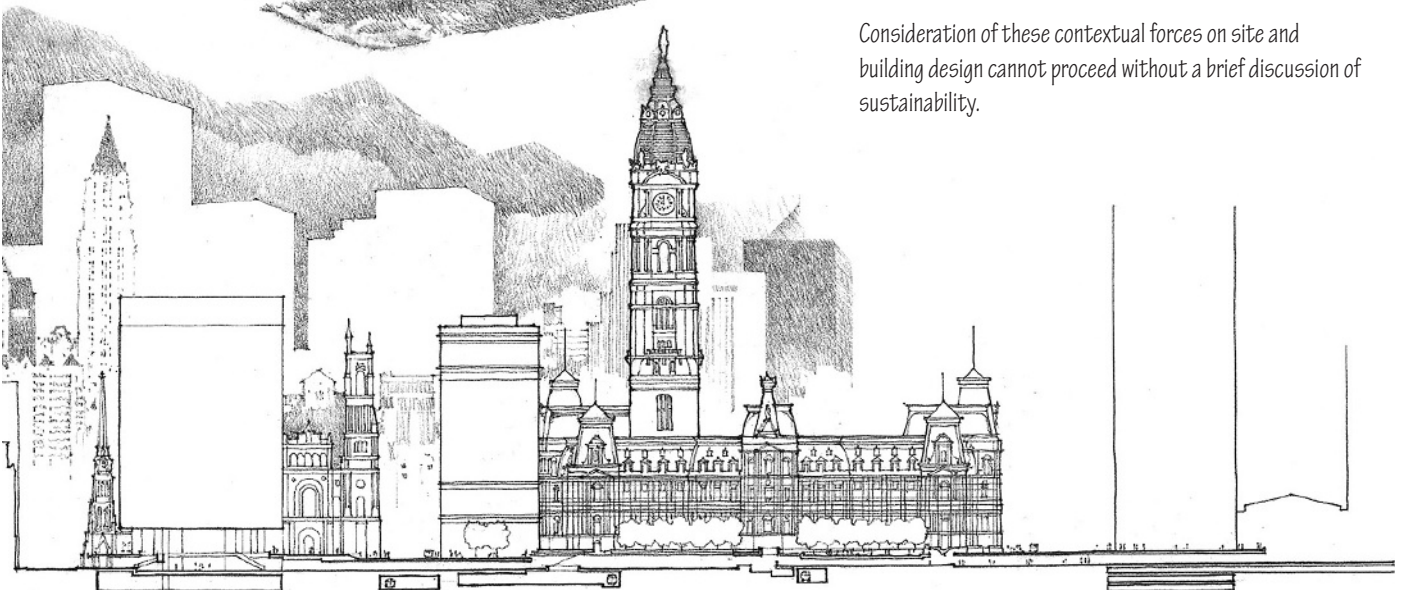

In 1987, the United Nations World Commission on Environment and Development, chaired by Gro Harlem Brundtland, former Prime Minister of Norway, issued a report, *Our Common Future*. Among its findings, the report defined sustainable development as “a form of development that meets the needs of the present without compromising the ability of future generations to meet their own needs.”

Increasing awareness of the environmental challenges presented by climate change and resource depletion has pushed sustainability into becoming a significant issue shaping how the building design industry operates. Sustainability is necessarily broad in scope, affecting how we manage resources as well as build communities, and the issue calls for a holistic approach that considers the social, economic, and environmental impacts of development and requires the full participation of planners, architects, developers, building owners, contractors, and manufacturers, as well as governmental and nongovernmental agencies.

In seeking to minimize the negative environmental impact of development, sustainability emphasizes efficiency and moderation in the use of materials, energy, and spatial resources. Building in a sustainable manner requires paying attention to the predictable and comprehensive outcomes of decisions, actions, and events throughout the life cycle of a building, from conception to the siting, design, construction, use, and maintenance of new buildings as well as the renovation process for existing buildings and the reshaping of communities and cities.

Principles

- Reduce resource consumption
- Reuse resources
- Recycle resources for reuse
- Protect nature
- Eliminate toxins
- Apply life cycle costing
- Focus on quality

Framework for Sustainable Development

In 1994, Task Group 16 of the International Council for Research and Innovation in Building and Construction proposed a three-dimensional framework for sustainable development.

Resources

- Land
- Materials
- Water
- Energy
- Ecosystems

Phase

- Planning
- Development
- Design
- Construction
- Use & Operation
- Maintenance
- Modification
- Deconstruction

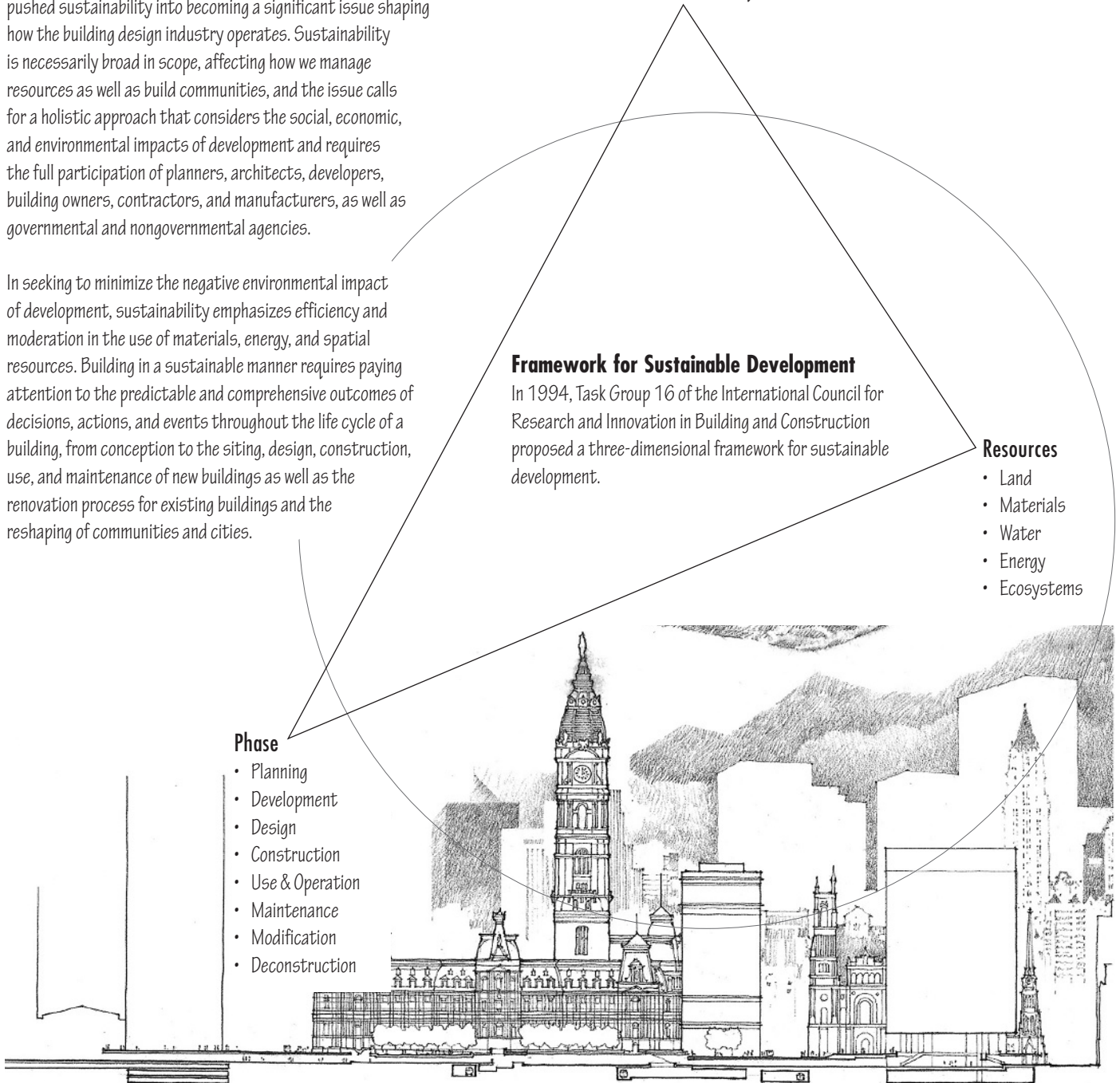
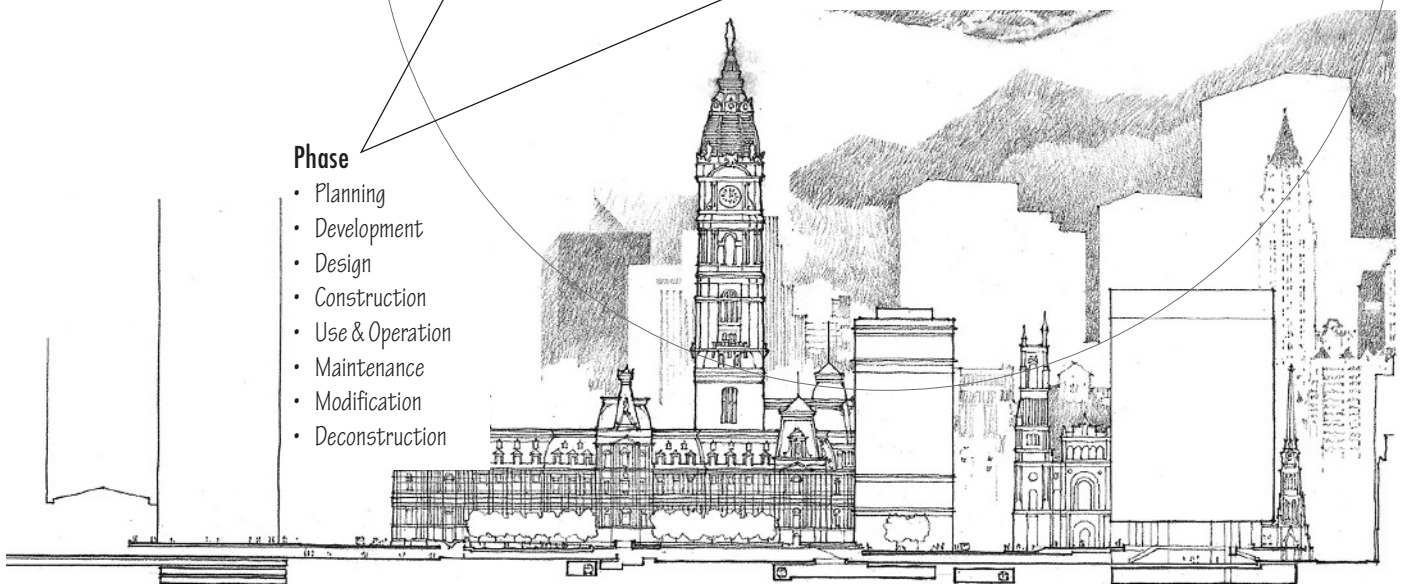

1.04 GREEN BUILDING

The terms “green building” and “sustainable design” are often used interchangeably to describe any building designed in an environmentally sensitive manner. However, sustainability calls for a whole-systems approach to development that encompasses the notion of green building but also addresses broader social, ethical, and economic issues, as well as the community context of buildings. As an essential component of sustainability, green building seeks to provide healthy environments in a resource-efficient manner, using ecologically based principles.

LEED®

Green building is increasingly governed by standards, such as the Leadership in Energy and Environmental Design (LEED®) Green Building Rating System™, which provides a set of measurable criteria that promote environmentally sustainable construction. The U.S. Green Building Council (USGBC) developed the rating system as a consensus among its members—federal/state/local agencies, suppliers, architects, engineers, contractors, and building owners—and it is continually being evaluated and refined in response to new information and feedback. While developed initially for the U.S., the LEED rating system is now used in more than 135 countries, partly because it allows for local and regional equivalencies to the referenced standards.

There are a number of LEED rating systems available to meet the needs of different building and project types:

- LEED v4.1 for Building Design and Construction—
New construction and major renovations
- LEED v4.1 for Interior Design and Construction—
Interior spaces
- LEED v4.1 for Building Operations and Maintenance—
Existing buildings undergoing improvements
- LEED v4.1 for Neighborhood Development—
New land development and redevelopment projects

Each rating system may have several variations that tailor the requirements to specific end uses, such as core and shell development, schools, retail sales, data centers, warehouses and distribution centers, hospitality businesses, and healthcare facilities.

The LEED rating system for new construction addresses nine major areas of development. (See Appendix for an outline of LEED v4.1 categories and credits.)



1. Integrative Process

rewards the analysis of energy and water systems early in the design process.

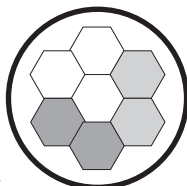

2. Location & Transportation

promotes compact development within existing patterns of development to protect sensitive sites and avoid the material and ecological costs of creating new infrastructure and hardscape; encourages realistic alternatives to private automobile use, such as the development of walking and biking paths, access to public transit, and proximity to community services and amenities; and advocates for the use of electric vehicles.

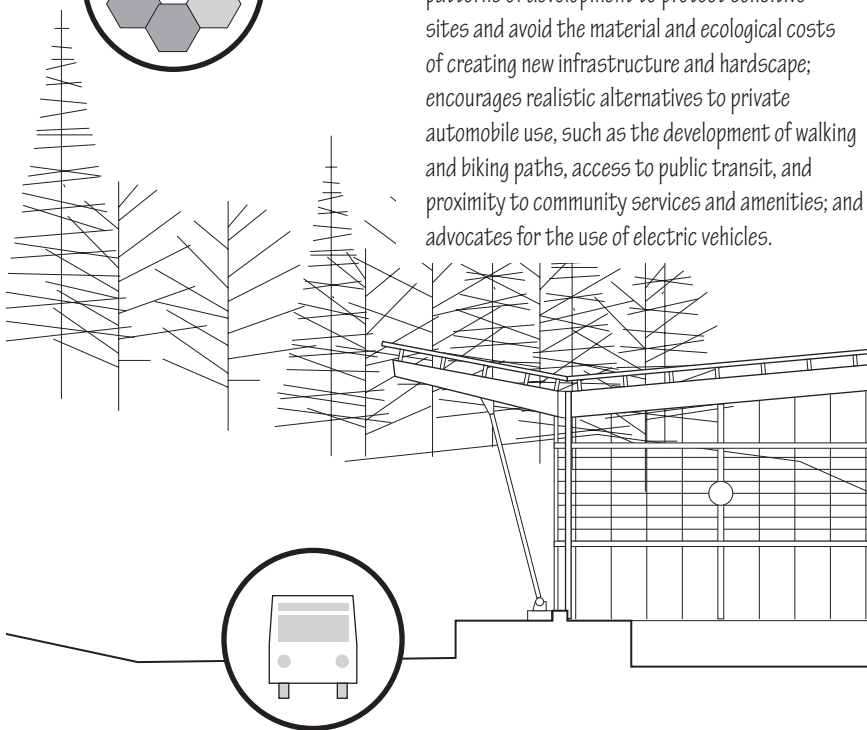

3. Sustainable Sites

encourages selecting sites appropriate for development, using low-impact development methods that minimize construction pollution, protecting environmentally sensitive areas and restoring damaged habitats, respecting the natural water hydrology of a site to manage rainwater runoff, and reducing the effects of heat islands and light pollution.

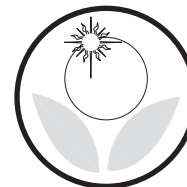

4. Water Efficiency

promotes lowering the demand for potable water and reducing the generation of wastewater by using water-conserving fixtures, harvesting rainwater, recycling gray water for conveying sewage, incorporating native landscapes that reduce the need for irrigation, and treating wastewater with on-site systems.

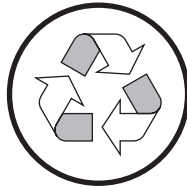

5. Energy & Atmosphere

treats energy in a holistic manner by promoting designs that reduce overall energy needs and increase the efficiency with which energy is acquired and used; increasing renewable, nonpolluting energy sources to reduce the environmental and economic impacts associated with fossil fuel energy use; and minimizing the emissions that contribute to ozone depletion and global warming.

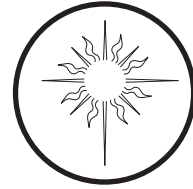

6. Material & Resources

seeks to minimize waste by reducing the weight, volume, or toxicity of materials and products throughout their life cycle, from supply chain and use to recycling and disposal; reusing existing materials and building stock to reduce the production and transportation of new materials; recycling materials to divert waste from landfills; and developing waste-to-energy solutions as viable alternatives to fossil fuel energy.

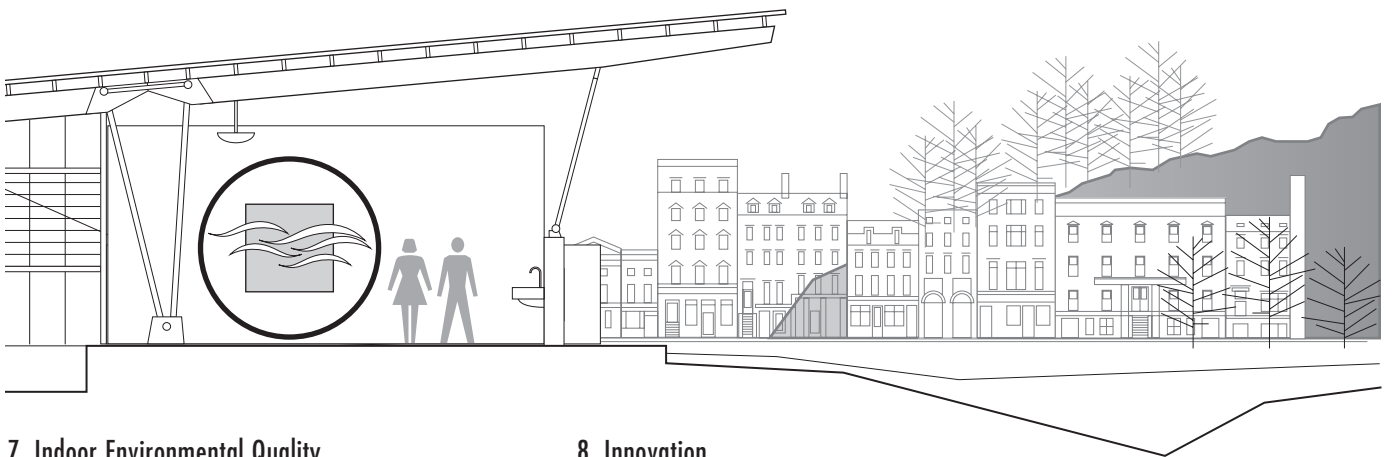

7. Indoor Environmental Quality

promotes the enhanced comfort, productivity, and well-being of building occupants by improving indoor air quality, maximizing daylighting of interior spaces, enabling user control of lighting and thermal comfort systems to suit task needs and preferences, and minimizing the exposure of building occupants to potentially hazardous particulates and chemical pollutants, such as the volatile organic compounds (VOC) contained in adhesives and coatings and the urea-formaldehyde resins in composite wood products.

8. Innovation

rewards exceeding the requirements set by the LEED Green Building Rating System and/or demonstrating innovative building features and sustainable design strategies in Green Building categories not specifically addressed by the LEED Green Building Rating System.

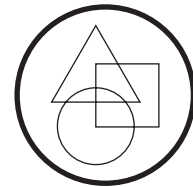

9. Regional Priority

provides incentives for practices that address geographically specific and local environmental priorities.

1.06 GREEN BUILDING STANDARDS

The Future of LEED

Since its inception in 2000, LEED has transformed from focusing on the construction of new commercial buildings to addressing a variety of building types and enlarging its scope to include neighborhoods and communities. In its pursuit to align its goals with the Paris Climate Accord's 2030 and 2050 targets, a new version, LEED v5, is restructuring its framework around three primary goals:

1. Climate action
2. Quality of life
3. Ecological conservation and restoration

Related to these are five guiding principles:

- **Decarbonization:** Decarbonize the building industry swiftly to reflect the urgency of the climate crisis and move toward achieving the 2030 and 2050 Paris Climate Accord targets.
- **Resilience:** Encourage adaptive and resilient built environments by identifying risks, integrating adaptation strategies, facilitating recovery from disruptive events, and maintaining appropriate habitability.
- **Health:** Invest in human health and well-being by promoting the use of healthy materials, improving the quality of indoor and outdoor environments, and advocating for a holistic approach to mental and physical health.
- **Equity:** Create environments in which diversity, equity, and inclusivity thrive, especially by providing access for all to the benefits of green building.
- **Ecosystems:** Support thriving ecosystems through regenerative development practices to create resilient and self-sustaining communities and promote life for all beings.

The sample matrix to the left illustrates possible relations between these core goals and guiding principles. The USGBC anticipates that this framework will emphasize the integrative nature of how credits can be allotted and result in more flexibility in credit compliance. For example, the principle of decarbonization could be incorporated into credits based on the rate of decarbonization, prioritization of passive efficiency, improvements in indoor air quality, accountability for climate change, and the life cycle analysis and reuse of materials.

	Climate Action	Quality of Life	Ecology
Decarbonization	Decarbonize swiftly	Prioritize passive efficiency for survivability; Improve indoor air quality without IC; Account for who causes climate change	Emphasize life cycle analysis and reuse of materials
Resilience			
Health & Well-Being			
Equity			
Ecosystems			

BREEAM

Another green rating system is the Building Research Environmental Assessment Method (BREEAM), established in the United Kingdom by the Building Research Establishment (BRE) for specifying, measuring, and rating the sustainability and environmental performance of master-planned communities, buildings, and major renovations. Launched in 1990, it is one of the oldest and most widely adopted green rating systems. Extensively used in Europe, BREEAM has also been implemented in construction around the world.

BREEAM assesses life cycle performance from concept through construction and use, and requires evidence that the quality and performance standards are met in the following areas: management, water, energy, transport, health and well-being, resources, resilience, land use and ecology, pollution, materials, waste, and innovation.

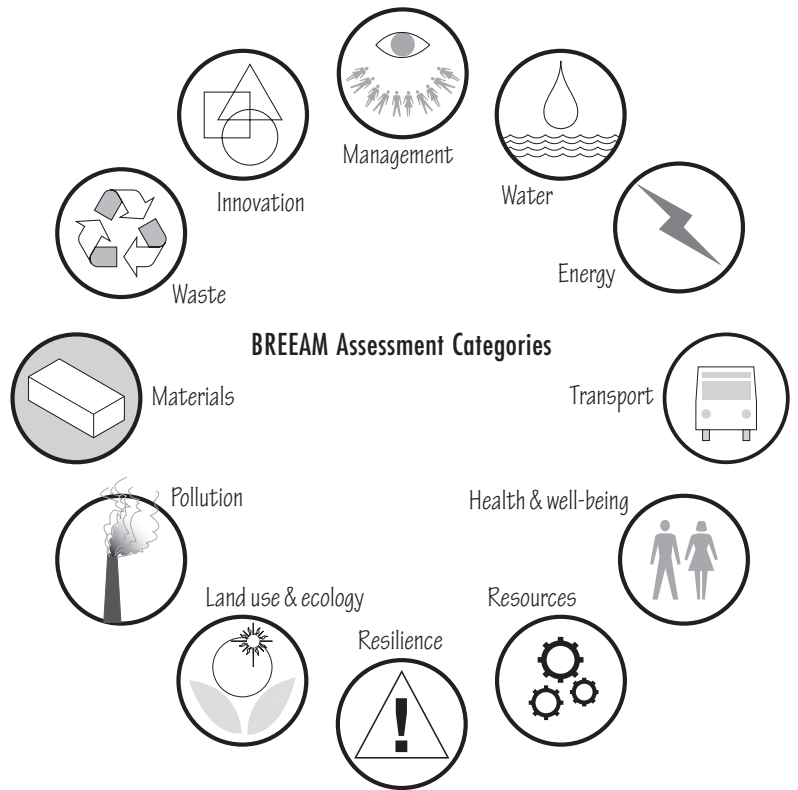

Green Globes

Green Globes is a voluntary certification system that evaluates the environmental sustainability, health and wellness, and resilience of all types of commercial real estate. Green Globes originated from the BREEAM system but is now administered in the United States by the Green Building Initiative (GBI) and in Canada by its wholly owned, nonprofit subsidiary, GB Initiative Canada. The Green Globes system focuses on life cycle assessment in seven areas: sustainable sites, energy efficiency, water efficiency, materials and resource use, indoor environmental quality, emissions, and project and environmental management.

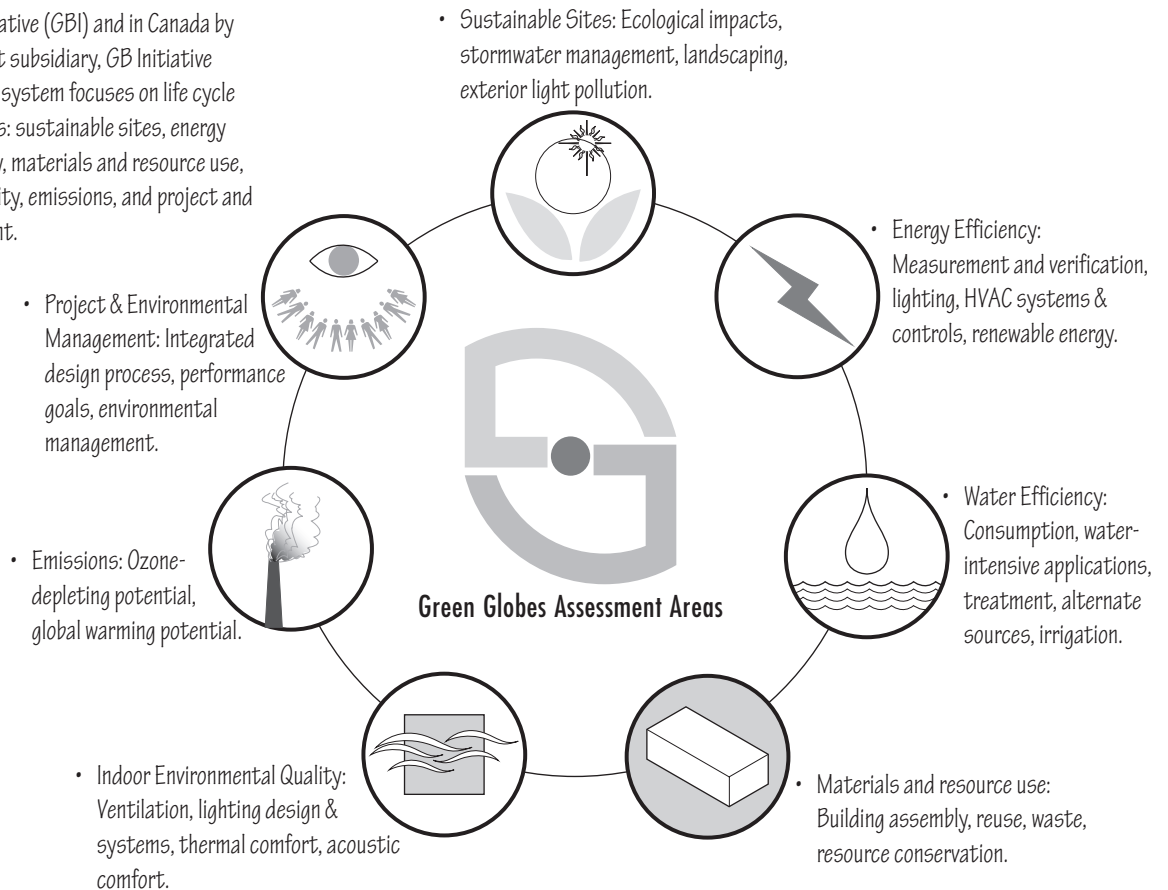

1.08 GREEN BUILDING STANDARDS

Passivhaus

Passivhaus is a standard developed in Europe to produce ultra-low-energy buildings by combining excellent thermal performance and airtightness with a heat-recovery ventilation system that supplies fresh air for indoor environmental quality. The goal is to provide a high level of occupant comfort while using very little energy for heating and cooling. While its name implies application primarily in the residential sector, the principles of the Passivhaus standard can also be applied to commercial, industrial, and public buildings.

The standard contains both a predictive design goal—a maximum energy demand of 120 kWh/m² (11.1 kWh/ft²)—and an actual performance goal of an infiltration rate no greater than 0.60 air changes per hour @ 50 pascals. The latter requires that construction be meticulously detailed to limit infiltration, which is a major cause of increased energy usage.

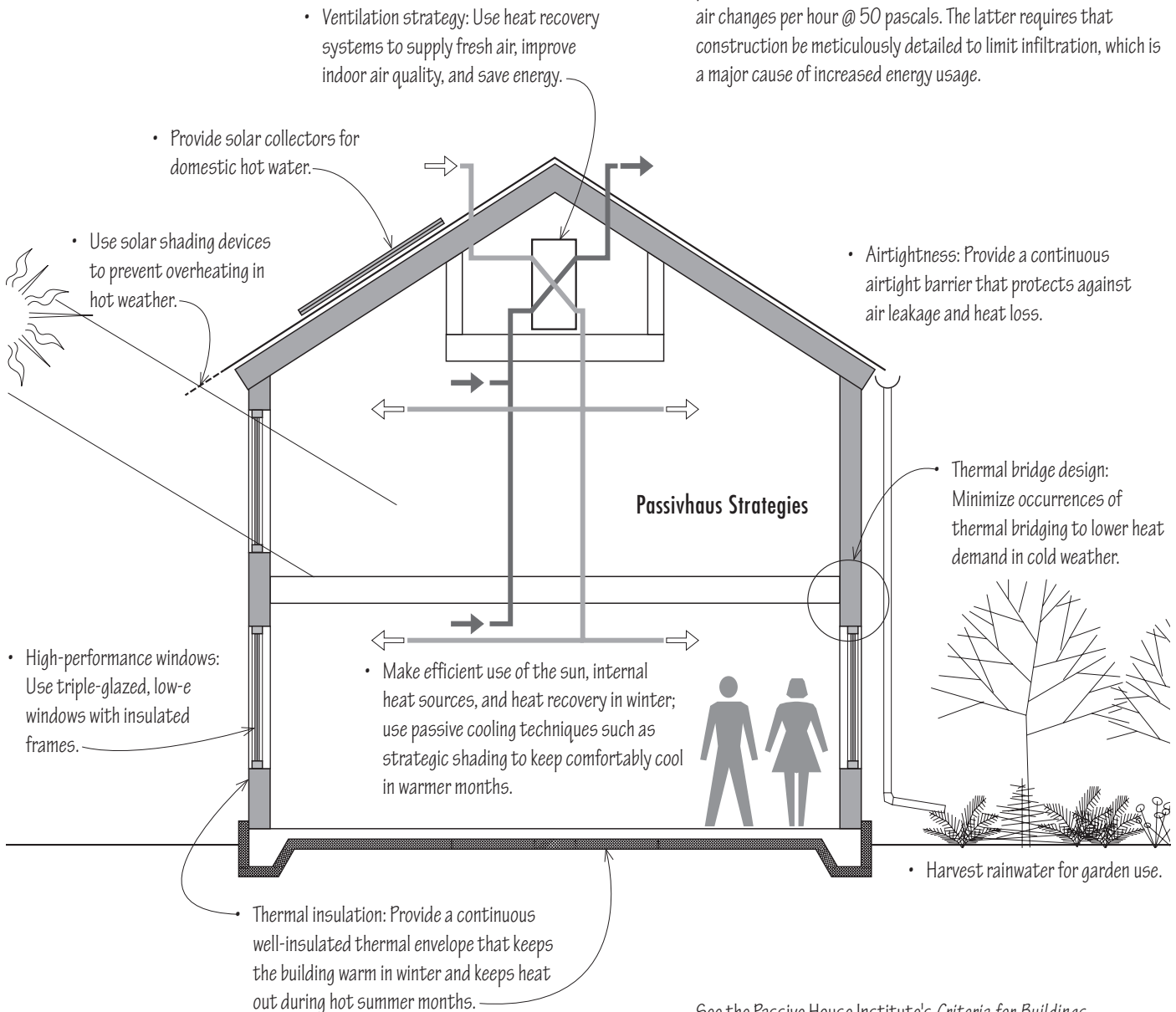

See the Passive House Institute's *Criteria for Buildings* for more information and detailed criteria on the different Passivhaus classes: Classic, Plus, & Premium.

Living Building Challenge

The Living Building Challenge (LBC) is a standard created in 2006 and maintained by the International Living Future Institute (ILFI) for development at all scales, from buildings to infrastructure, landscapes, and neighborhoods. The LBC differentiates itself from other standards by requiring actual, measured performance supported by data gathered over a minimum of 12 months of continuous occupancy and operations. The standard also contains bold requirements in other green building areas, such as site selection and preservation, material selection, and health. Of note is the inclusion of beauty and equity as major areas of green building design.

The ILFI uses the flower as a metaphor for its framework of requirements. There are seven performance areas or “petals”: place, water, energy, health and happiness, materials, equity, and beauty. These petals are further subdivided into twenty “imperatives” required for full LBC certification.

- Ecology of place
 - Urban agriculture
 - Habitat exchange
- Human-scaled living
- Responsible water use
 - Net positive water
- Energy + carbon reduction
 - Net positive carbon
- Healthy interior environment
 - Healthy interior performance
 - Access to nature
- Responsible materials
 - Red list (of harmful chemicals)
 - Responsible sourcing
 - Living economy sourcing
 - Net positive waste
- Universal access
- Inclusion
- Beauty + Biophilia
- Education + Inspiration

For a Core LBC certification, only the ten underlined imperatives are required.

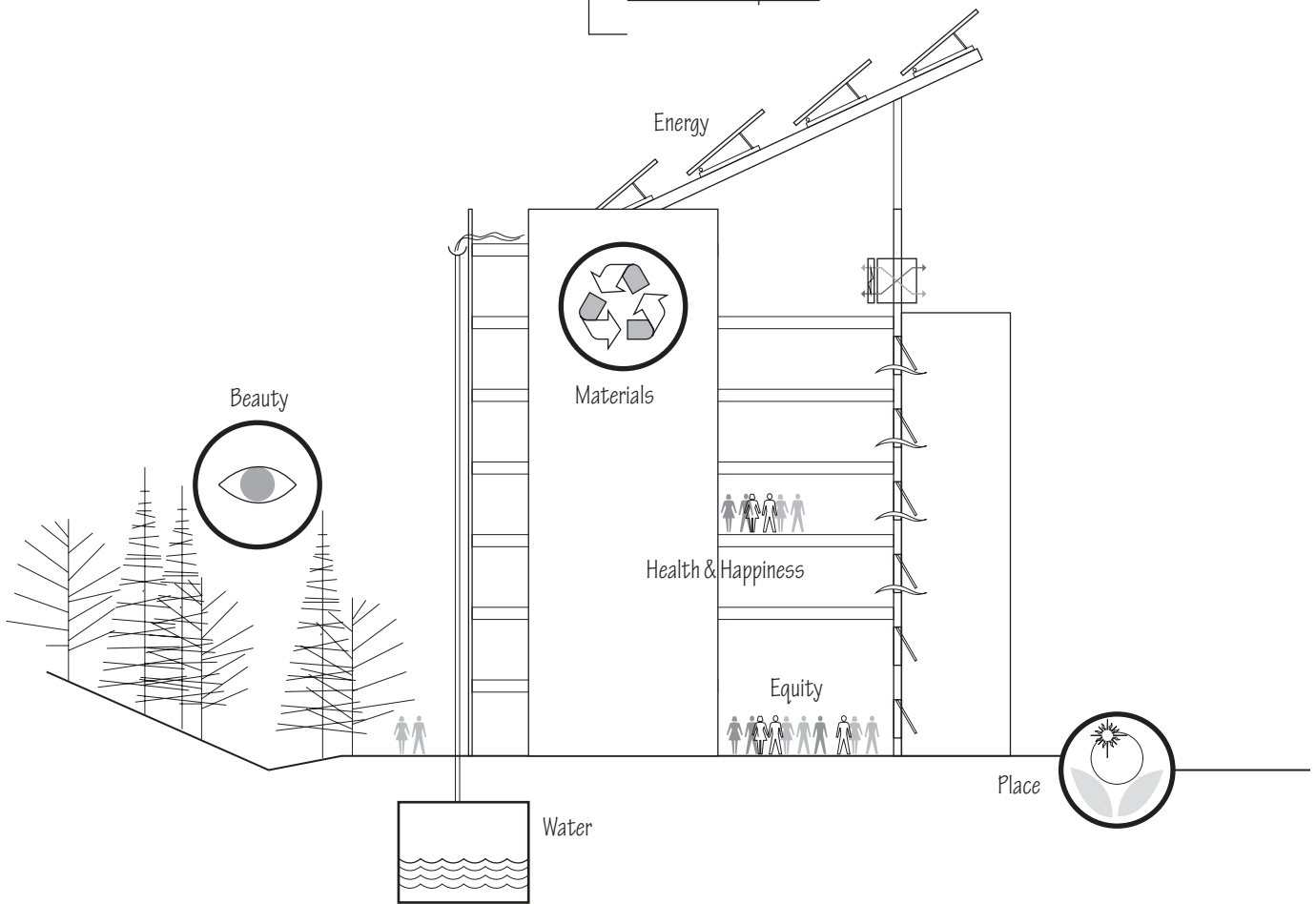

Performance Areas of the Living Building Challenge

1.10 GREEN BUILDING STANDARDS

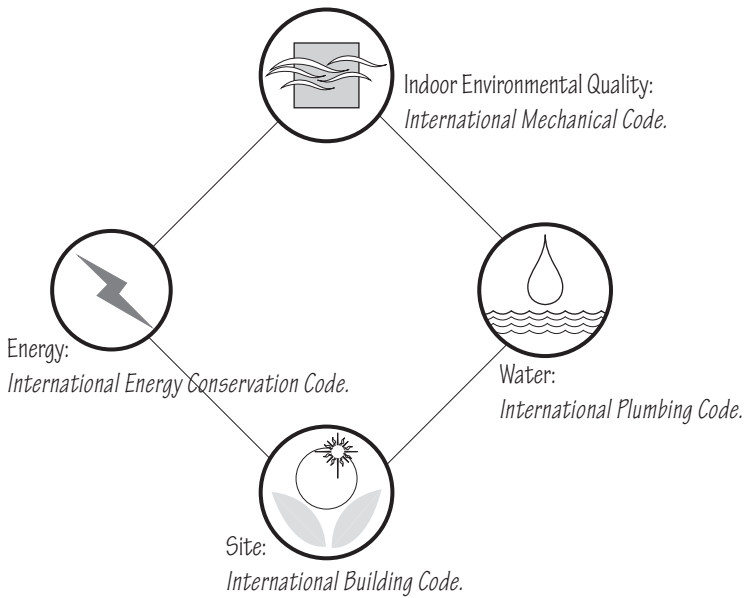

The *International Green Construction Code*®

The *International Building Code*® (IBC) is a comprehensive model code developed, published, and maintained by the International Code Council (ICC). (see 2.08). The IBC and its associated I-codes contain a broad number of green provisions, including requirements for energy conservation in the *International Energy Conservation Code*®, requirements for ventilation in the *International Mechanical Code*®, and requirements for water conservation in the *International Plumbing Code*®.

In 2012, the ICC released the *International Green Construction Code*® (IgCC®) in collaboration with the American Institute of Architects (AIA), the United States Green Building Council (USGBC), the American Society of Heating, Refrigerating and Air-Conditioning Engineers (ASHRAE), the Illuminating Engineering Society (IES), and ASTM International. The IgCC is designed to promote safe and sustainable construction in concert with the ICC family of codes.

The 2021 edition of the IgCC uses the provisions of the 2020 edition of ANSI/ASHRAE/ICC/USGBC/IES Standard 189.1, *Standard for the Design of High Performance Green Buildings Except Low-Rise Residential Buildings*. These provisions govern site sustainability, water use efficiency, energy efficiency, indoor environmental quality, materials and resources, and construction and operational plans.

- Construction and operational plans: Prevent construction activity pollution, protect occupied areas, and manage transportation and service life plans.
- Site sustainability: Mitigate heat island effect, reduce light pollution, promote green transportation options, and manage site waste.

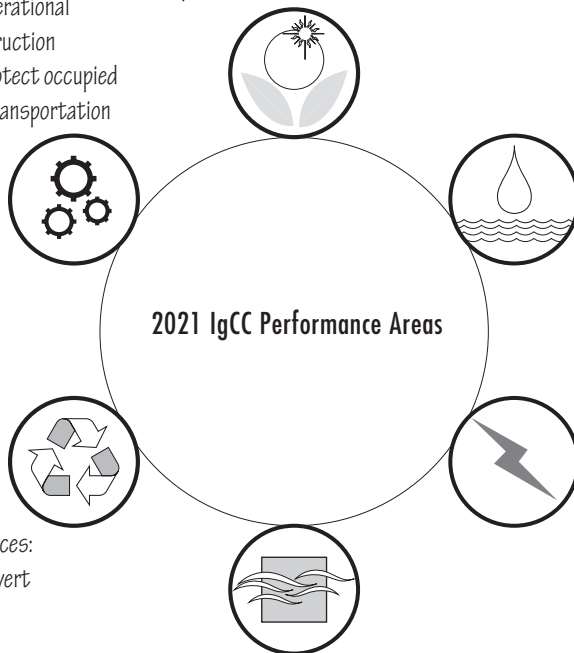

- Water use efficiency: Conserve water by reducing water usage and harvesting water used.
- Energy efficiency: Conserve energy by regulating building envelope and orientation, ventilation controls, exhaust air energy recovery systems, occupancy sensor controls, programmable thermostats, and energy simulation design.
- Indoor environmental quality: Regulate ventilating air quality, interior sound reverberation, exterior views, and shading for offices.
- Materials and resources: Reduce waste and divert waste from landfills.

Living or working in a building that is built to code, is comfortable, and is energy efficient may not matter if it becomes uninhabitable due to an earthquake, flood, wildfire, or some other disaster. This possibility has given rise to the field of resilient design, which the Resilient Design Institute defines as “the intentional design of buildings, landscapes, communities, and regions in response to natural and manmade disasters and disturbances—as well as long-term changes resulting from climate change—including sea level rise, increased frequency of heat waves, and regional drought.” The goals are to design, construct, and renovate buildings to handle natural disasters as well as maintain livable conditions in the event of an extended loss of power or heat.

The principles and strategies of resilient design apply not only to buildings but also to communities and regions, and recognize that the nature of possible disasters and disturbances may vary with locale. For example, high winds and flooding may be prevalent in one locale, while blizzards as well as large temperature swings might present a greater potential problem in another. In still another region, seismic activity might be the primary concern.

While the principles and strategies of sustainable design and resilient design may sometimes seem at odds, there is still much overlap.

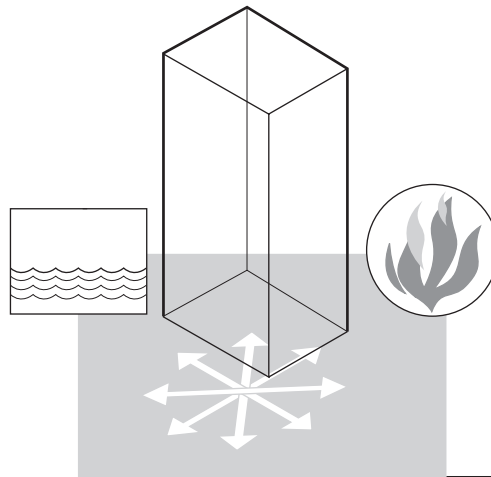

- Provide for basic human needs, such as potable water, safe air, occupant health, and food distributed equitably.
- Rely on diverse and redundant systems for such needs as electricity, water, and transportation.
- Emphasize the use of passive systems for heating and cooling.
- Use simple and flexible systems rather than complex operations that require ongoing maintenance.
- Be locally specific when designing responses to possible disturbances.
- Design and build for durability and robustness to withstand possible disasters as well as long-term wear and tear.
- Design buildings that can adapt to new and overlapping uses over time.

Resilient Design

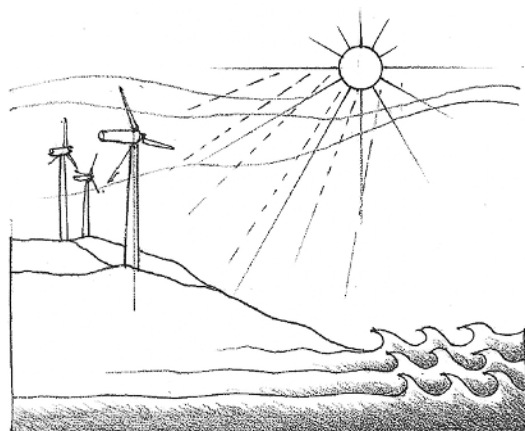

Sustainable Design

- Build in energy and water independence.
- Use locally sourced, renewable, or reclaimed materials and products.
- Employ locally available skill sets.
- Reduce demand for energy needs and increase efficient use of energy.
- Increase renewable, nonpolluting energy sources.
- Reduce demand for potable water and the generation of wastewater.
- Provide realistic alternatives to private automobile use.
- Restore habitat and brownfields, and protect environmentally sensitive areas.
- Respect the natural hydrology of a site.
- Promote compact development within existing patterns of development.
- Improve indoor air quality, maximize daylighting of interior spaces, and enable user control of lighting and thermal comfort systems.

1.12 THE 2030 CHALLENGE

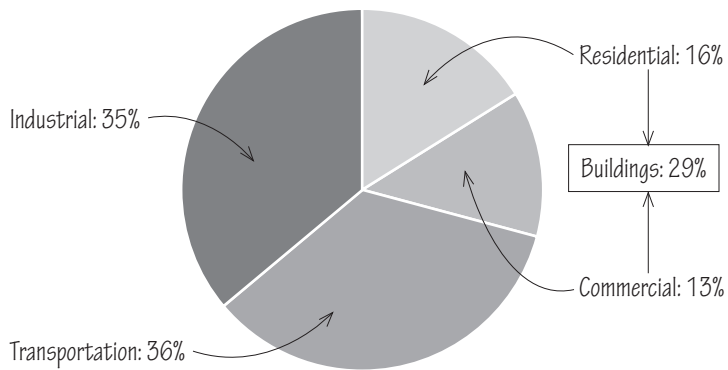

U.S. Energy Consumption by Sector in 2022

Source: U.S. Energy Information Administration / Public domain.

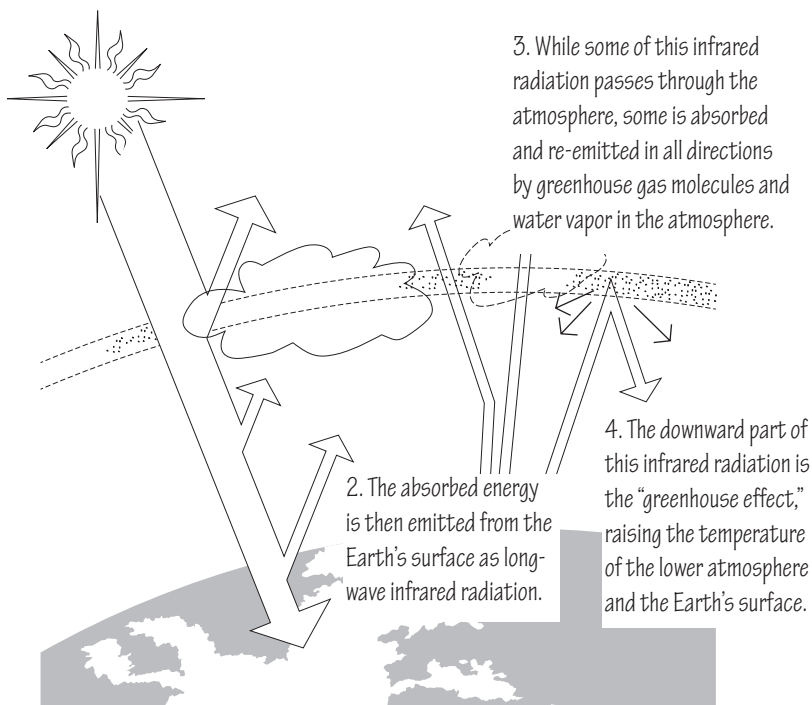

1. Some of the incoming solar radiation is reflected by the Earth and the atmosphere but most of the radiation is absorbed and warms the Earth's surface and atmosphere.

2. The absorbed energy is then emitted from the Earth's surface as long-wave infrared radiation.

4. The downward part of this infrared radiation is the "greenhouse effect," raising the temperature of the lower atmosphere and the Earth's surface.

Climate Change & Global Warming

Greenhouse gases, such as carbon dioxide, methane, and nitrous oxide, are emissions that rise into the atmosphere. CO₂ accounts for the largest share of U.S. greenhouse gas emissions. Fossil fuel combustion is the main source of CO₂ emissions.

Architecture 2030 is an environmental advocacy group whose mission is "to provide information and innovative solutions in the fields of architecture and planning, in an effort to address global climate change." Its founder, New Mexico architect Edward Mazria, points to data from the U.S. Energy Information Administration that indicates buildings are responsible for approximately 30% of the total U.S. energy consumption and greenhouse gas (GHG) emissions annually. Globally, Mazria believes the urban built environment is responsible for 75% of annual global GHG emissions. Eliminating these emissions is key to addressing climate change.

What is relevant to any discussion of sustainable design is that most of the building sector's energy consumption is not attributable to the production of materials or the process of construction, but rather to operational processes—the heating, cooling, and lighting of buildings. This means that to reduce the energy consumption and GHG emissions generated by the use and maintenance of buildings over their lifespan, it is necessary to properly design, shape, and site buildings and incorporate natural heating, cooling, ventilation, and daylighting strategies.

In 2006, Architecture 2030 issued the 2030 Challenge, which calls for all new buildings, developments, and major renovations to be carbon-neutral by 2030 (using no fossil-fuel GHG-emitting energy to build and operate). To accomplish this goal, the 2030 Challenge advocates for all new buildings to use less than half the fossil fuel energy they would typically consume, and for an equal amount of existing building area to be renovated annually to meet the same energy consumption standard.

There are two approaches to reducing a building's consumption of GHG-emitting fossil fuels. The passive approach is to work with the climate in designing, siting, and orienting a building and employ passive cooling and heating techniques to reduce its overall energy requirements. The active approach is to increase the ability of a building to capture or generate its own energy from renewable sources (solar, wind, geothermal, low-impact hydro, biomass, and biogas) that are available locally and in abundance. While striking an appropriate, cost-effective balance between energy conservation and generating renewable energy is the goal, minimizing energy use is a necessary first step, irrespective of the fact that the energy may come from renewable resources.

Site analysis is the process of studying the contextual forces that influence how we might situate a building, lay out and orient its spaces, shape and articulate its enclosure, and establish its relationship to the landscape. Any site survey begins with the gathering of physical site data.

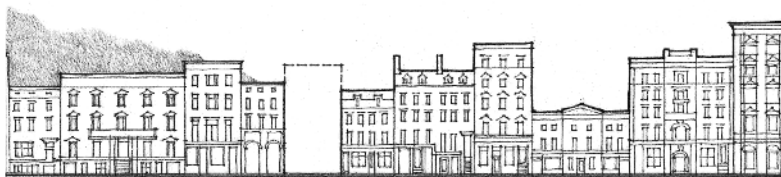
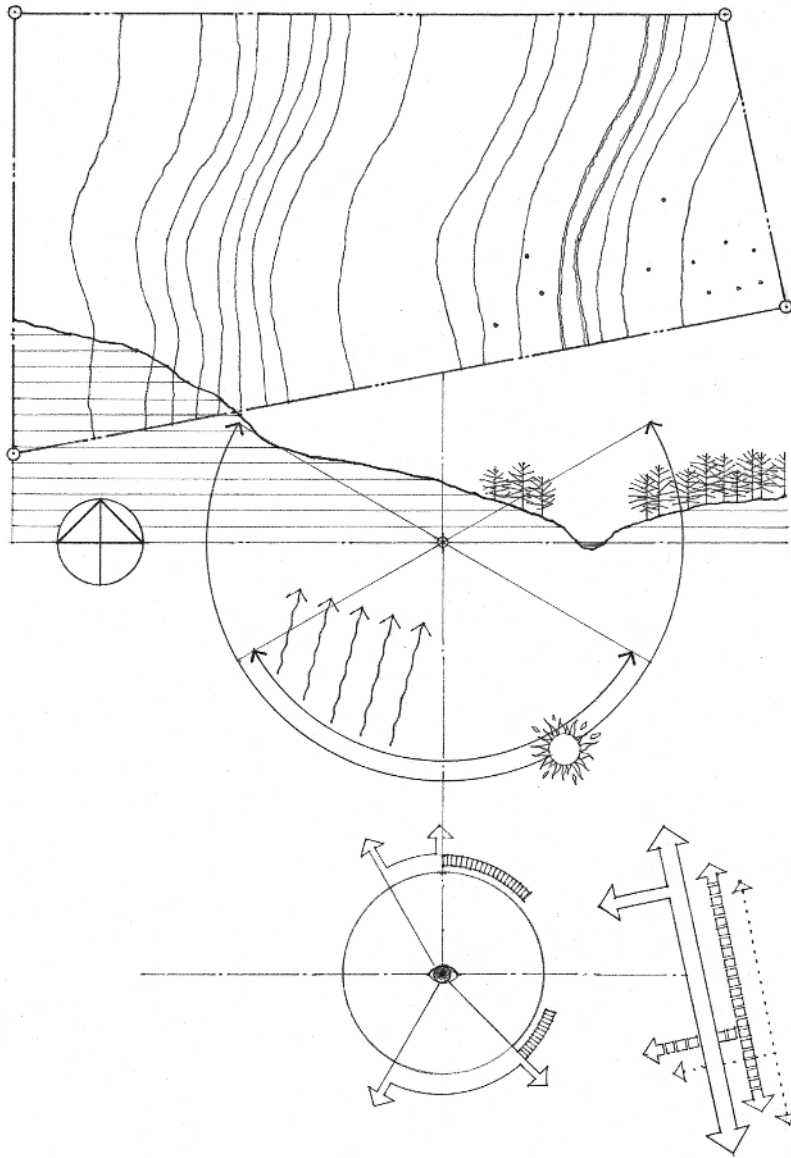

- Draw the area and shape of the site as defined by its legal boundaries.
- Indicate required setbacks, existing easements, and rights-of-way.
- Estimate the area and volume required for the building program, site amenities, and future expansion, if desired.
- Analyze the ground slopes and subsoil conditions to locate the areas suitable for construction and outdoor activities.
- Identify steep and moderate slopes that may be unsuitable for development.
- Locate soil areas suitable for use as a drainage field, if applicable.
- Map existing drainage patterns (LEED SS Credit 4: Rainwater Management).
- Determine the elevation of the water table.
- Identify areas subject to excessive runoff of surface water, flooding, or erosion.
- Locate existing trees and native plant materials that should be preserved.
- Chart existing water features, such as wetlands, streams, watersheds, flood plains, or shorelines that should be protected (LEED SS Credit 2: Sensitive Land Protection).
- Map climatic conditions: path of the sun, the direction of prevailing winds, and the expected amount of rainfall.
- Consider the impact of landforms and adjacent structures on solar access, prevailing winds, and the potential for glare.
- Evaluate solar radiation as a potential energy source.
- Determine possible points of access from public roadways and public transit stops (LEED LT Credit 5: Access to Quality Transit).
- Study possible circulation paths for pedestrians and vehicles from these access points to building entrances.
- Ascertain the availability of utilities: water mains, sanitary and storm sewers, gas lines, electrical power lines, telephone and cable lines, and fire hydrants.
- Determine access to other municipal services, such as police and fire protection.
- Identify the scope of desirable views as well as objectionable views.
- Cite potential sources of congestion and noise.
- Evaluate the compatibility of adjacent and proposed land uses.
- Map cultural and historical resources that should be preserved.
- Consider how the existing scale and character of the neighborhood or area might affect the building design.
- Map the proximity to public, commercial, medical, and recreational facilities (LEED LT Credit 1: LEED for Neighborhood Development Location and LT Credit 4: Surrounding Density and Diverse Uses).

1.14 SOILS

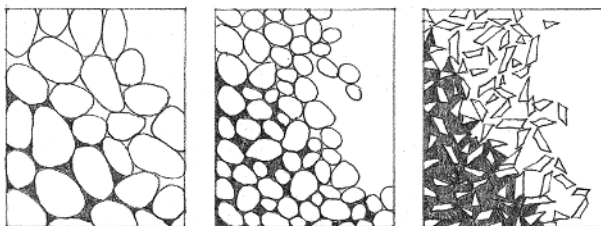

• Gravel • Sand • Clay

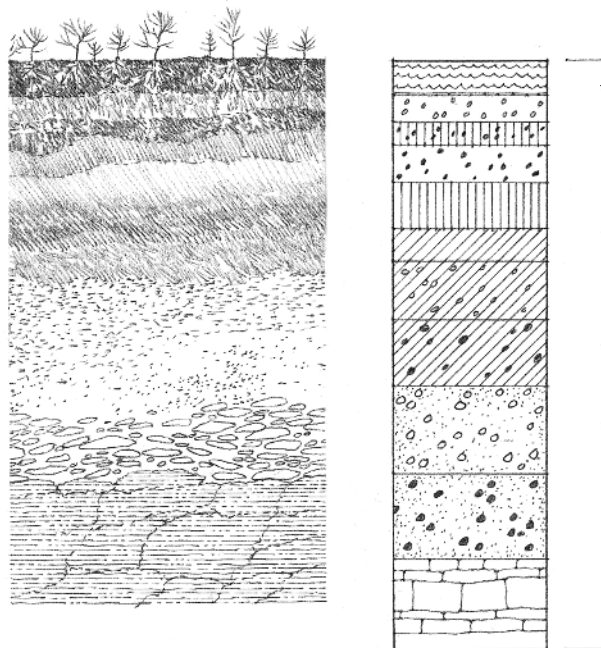

There are two broad classes of soils—coarse-grained soils and fine-grained soils. Coarse-grained soils include gravel and sand, which consist of relatively large particles visible to the naked eye; fine-grained soils, such as silt and clay, consist of much smaller particles. The American Society for Testing and Materials (ASTM) Unified Soil Classification System further divides gravels, sands, silts, and clays into soil types based on physical composition and characteristics. See table below.

The soil underlying a building site may actually consist of superimposed layers, each of which contains a mix of soil types, developed by weathering or deposition. To depict this succession of layers or strata called horizons, geotechnical engineers draw a soil profile, a diagram of a vertical section of soil from the ground surface to the underlying material, using information collected from a test pit or boring.

The integrity of a building structure depends ultimately on the stability and strength under loading of the soil or rock underlying the foundation. The stratification, composition, and density of the soil bed, variations in particle size, and the presence or absence of groundwater are all critical factors in determining the suitability of a soil as a foundation material. When designing anything other than a single-family dwelling, it is advisable to have a geotechnical engineer undertake a subsurface investigation.

A subsurface investigation (CSI MasterFormat™ 02 30 00; IBC § 1803) involves the analysis and testing of soil disclosed by excavation of a test pit up to 10' (3 m) deep or by deeper test borings in order to understand the structure of the soil, its shear resistance and compressive strength, its water content and permeability, and the expected extent and rate of consolidation under loading. From this information, the geotechnical engineer is able to gauge the anticipated total and differential settlement under loading by a proposed foundation system.

Soil Classification*	Symbol	Description	Presumptive Bearing Capacity†		Susceptibility to Frost Action	Permeability & Drainage	
			psf‡	kPa			
Gravels 6.4–76.2 mm	Clean gravels	GW	Well-graded gravel	10,000	479	None	Excellent
		GP	Poorly graded gravel	10,000	479	None	Excellent
	Gravels w/ fines	GM	Silty gravel	5000	239	Slight	Poor
		GC	Clayey gravel	4000	192	Slight	Poor
Sands 0.05–6.4 mm	Clean sands	SW	Well-graded sand	7500	359	None	Excellent
		SP	Poorly graded sand	6000	287	None	Excellent
	Sands w/ fines	SM	Silty sand	4000	192	Slight	Fair
		SC	Clayey sand	4000	192	Medium	Poor
Silts & Clays 0.002–0.05 mm <0.002 mm	LL > 50 [§]	ML	Inorganic silt	2000	96	Very high	Poor
		CL	Inorganic clay	2000	96	Medium	Impervious
	LL < 50 [§]	OL	Organic silt-clay		Very poor	High	Impervious
			MH	Elastic inorganic silt	2000	96	Very high
	CH	Plastic inorganic clay	2000	96	Medium	Impervious	
	OH	Organic clay and silt		Very poor	Medium	Impervious	
Highly organic soils	Pt	Peat		Unsuitable	Slight	Poor	

* Based on the ASTM Unified Soil Classification System; see also IBC Table 1806.2: Presumptive Load-Bearing Values.

† Consult a geotechnical engineer and the building code for allowable bearing capacities.

‡ 1 psf = 0.0479 kPa

§ LL = liquid limit: the water content, expressed as a percentage of dry weight, at which a soil passes from a plastic to a liquid state.

The allowable bearing capacity of a soil is the maximum unit pressure a foundation is permitted to impose vertically or laterally on the soil mass. In the absence of geotechnical investigation and testing, building codes may permit the use of conservative load-bearing values for various soil classifications. While high-bearing-capacity soils present few problems, low-bearing-capacity soils may dictate the use of a certain type of foundation and load distribution pattern, and ultimately, the form and layout of a building.

Density is a critical factor in determining the bearing capacity of granular soils. The standard penetration test measures the density of granular soils and the consistency of some clays at the bottom of a borehole, recording the number of blows required by a hammer to advance a standard soil sampler. In some cases, compaction, by means of rolling, tamping, or soaking to achieve optimum moisture content, can increase the density of a soil bed.

Coarse-grained soils have a relatively low percentage of void spaces and are more stable as a foundation material than silt or clay. Clay soils, in particular, tend to be unstable because they shrink and swell considerably with changes in moisture content. Unstable soils may render a site unbuildable unless an elaborately engineered and expensive foundation system is put in place.

The shearing strength of a soil is a measure of its ability to resist displacement when an external force is applied, due largely to the combined effects of cohesion and internal friction. On sloping sites, as well as during the excavation of a flat site, unconfined soil has the potential to displace laterally. Cohesive soils, such as clay, retain their strength when unconfined; granular soils, such as gravel, sand, or some silts, require a confining force for their shear resistance and have a relatively shallow angle of repose.

The water table is the level beneath which the soil is saturated with groundwater. Some building sites are subject to seasonal fluctuations in the level of groundwater. Any groundwater present must be drained away from a foundation system to avoid reducing the bearing capacity of the soil and to minimize the possibility of water leaking into a basement. Coarse-grained soils are more permeable and drain better than fine-grained soils, and are less susceptible to frost action.

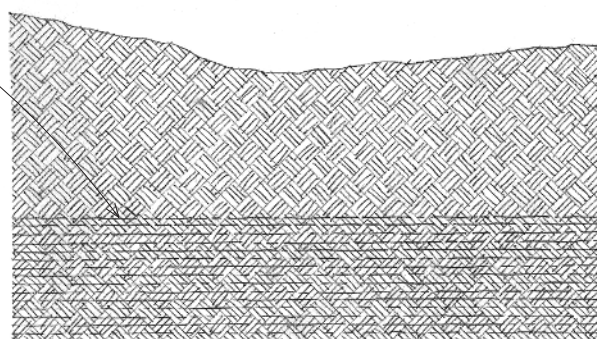
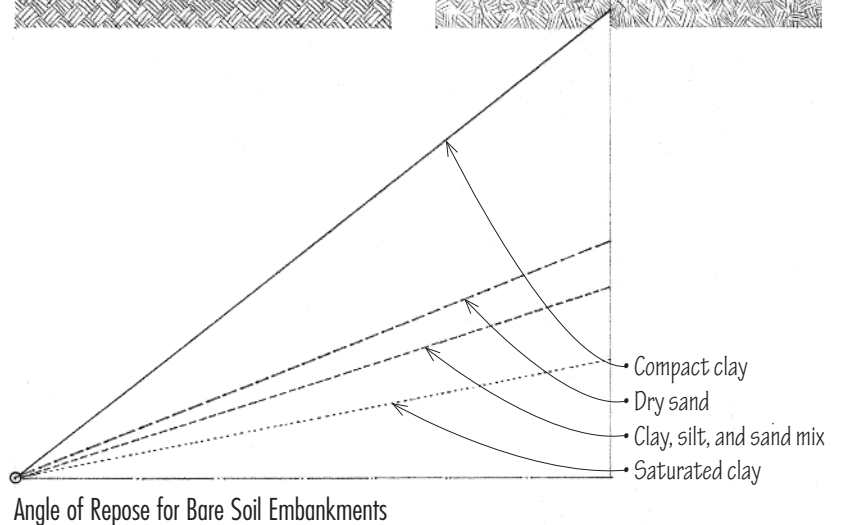
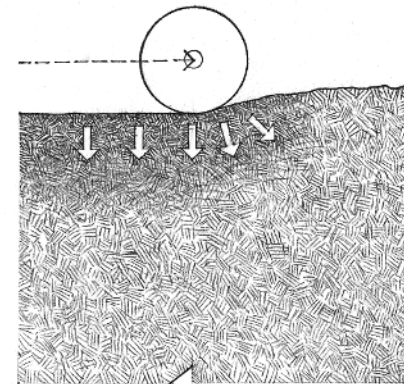
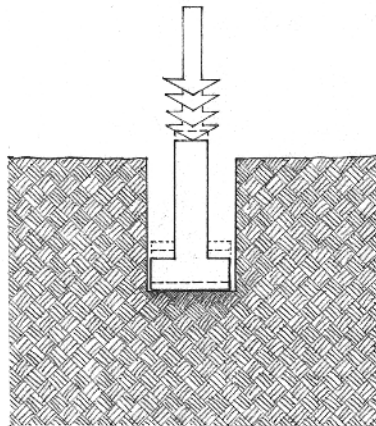
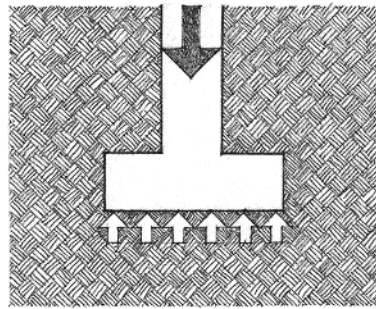

1.16 TOPOGRAPHY

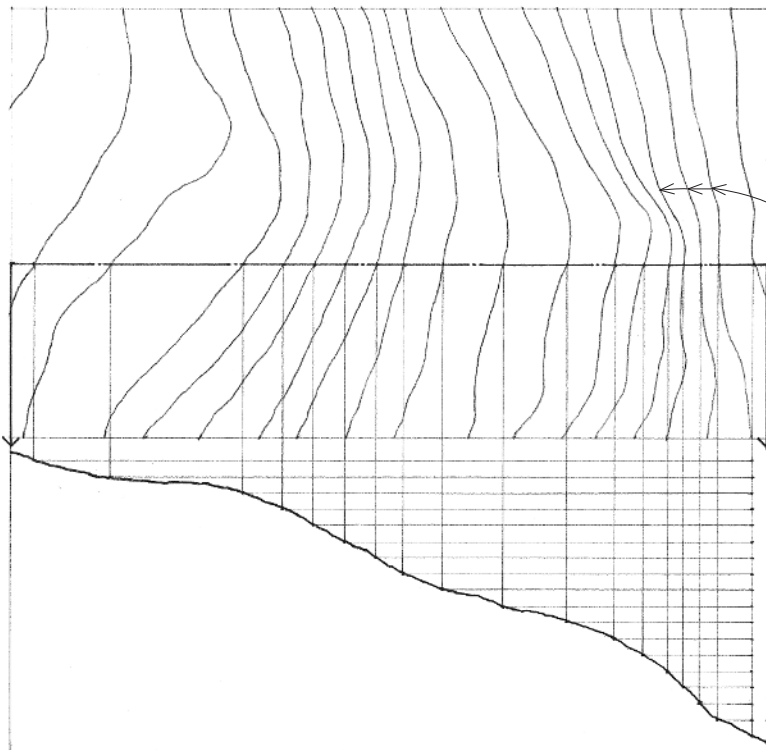

Topography refers to the configuration of surface features of a plot of land, which influences where and how to build and develop a site. To study the response of a building design to the topography of a site, we can use a series of site sections or a site plan with contour lines.

Contour lines are imaginary lines joining points of equal elevation above a datum or benchmark. The trajectory of each contour line indicates the shape of the land formation at that elevation. Note that contour lines are always continuous and never cross one another; they coincide in a plan view only when they cut across a vertical surface.

Contour interval refers to the difference in elevation represented by any two adjacent contour lines on a topographic map or site plan. The interval used is determined by the scale of a drawing, the size of the site, and the nature of the topography. The larger the area and the steeper the slopes, the greater the interval between contours. For large or steeply sloping sites, 20' or 40' (5 or 10 m) contour intervals may be used. For small sites having relatively gradual slopes, 1', 2', or 5' (0.5 or 1.0 m) contours may be necessary.

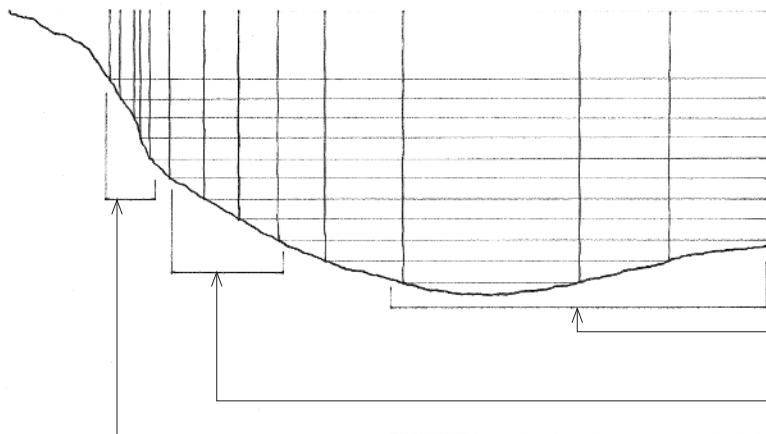

We can discern the topographical nature of a site by reading the horizontal spacing and shape of contour lines.

- Contours spaced far apart indicate a relatively flat or gently sloping surface.
- Equally spaced contours denote a constant slope.
- Closely spaced contours disclose a relatively steep rise in elevation.
- Contour lines represent a ridge when pointing toward lower elevations; they represent a valley when pointing toward higher elevations.

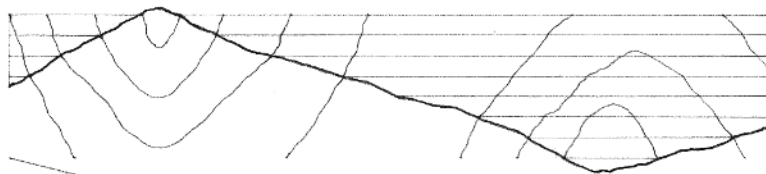

- Ground slopes over 25% are subject to erosion and are difficult to build on.
- Ground slopes over 10% are challenging to use for outdoor activities and are more expensive to build on.
- Ground slopes from 5% to 10% are suitable for informal outdoor activities and can be built on without too much difficulty.
- Ground slopes up to 5% are usable for most outdoor activities and are relatively easy to build on.

• $\text{Slope (\%)} = [\text{elevation gain (v)} / \text{horizontal distance (h)}] \times 100$

The ground slope between any two contour lines is a function of the total change in elevation and the horizontal distance between the two contours.

For aesthetic and economic as well as ecological reasons, the general intent in developing a site should be to minimize the disturbance of existing landforms and features while taking advantage of natural ground slopes and the microclimate of the site.

- Site development and construction should minimize disrupting the natural drainage patterns of the site and adjacent properties.
- When modifying landforms, include provisions for the drainage of surface water and groundwater.
- Attempt to equalize the amount of cut and fill required for construction of a foundation and site development.
- Avoid building on steep slopes subject to erosion or slides.
- Wetlands and other wildlife habitats may require protection and limit the buildable area of a site.
- Pay particular attention to building restrictions on sites located in or near a flood plain.

- Elevating a structure on poles or piers minimizes disturbance of the natural terrain and existing vegetation.
- Terracing or stepping a structure along a slope requires excavation and the use of retaining walls or bench terracing.
- Cutting a structure into a slope or locating it partially underground moderates temperature extremes and minimizes exposure to wind, and heat loss in cold climates.

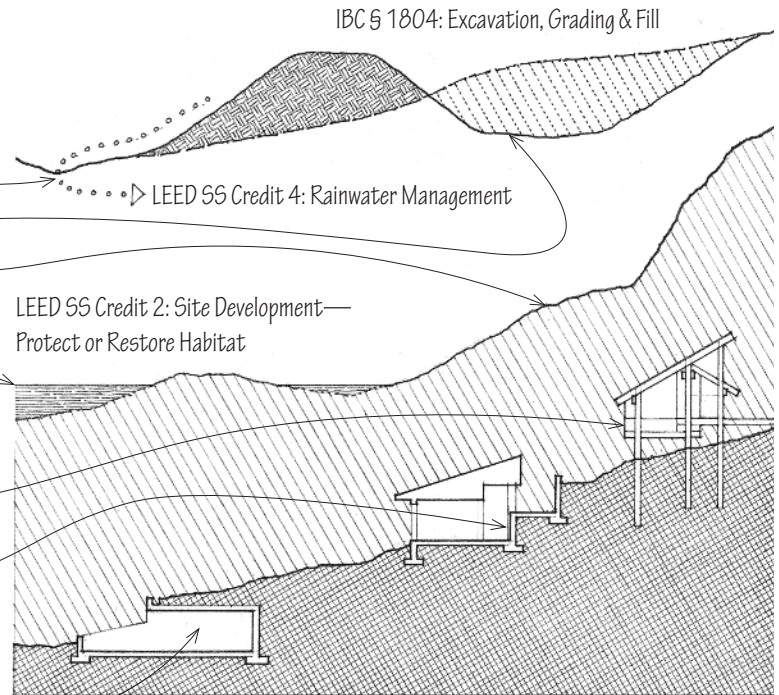

• The temperature in the atmosphere decreases with altitude—approximately 1°F (0.56°C) for every 400' (122 m) in elevation.

- Warm air rises.
- Heavier cool air settles into low-lying areas.

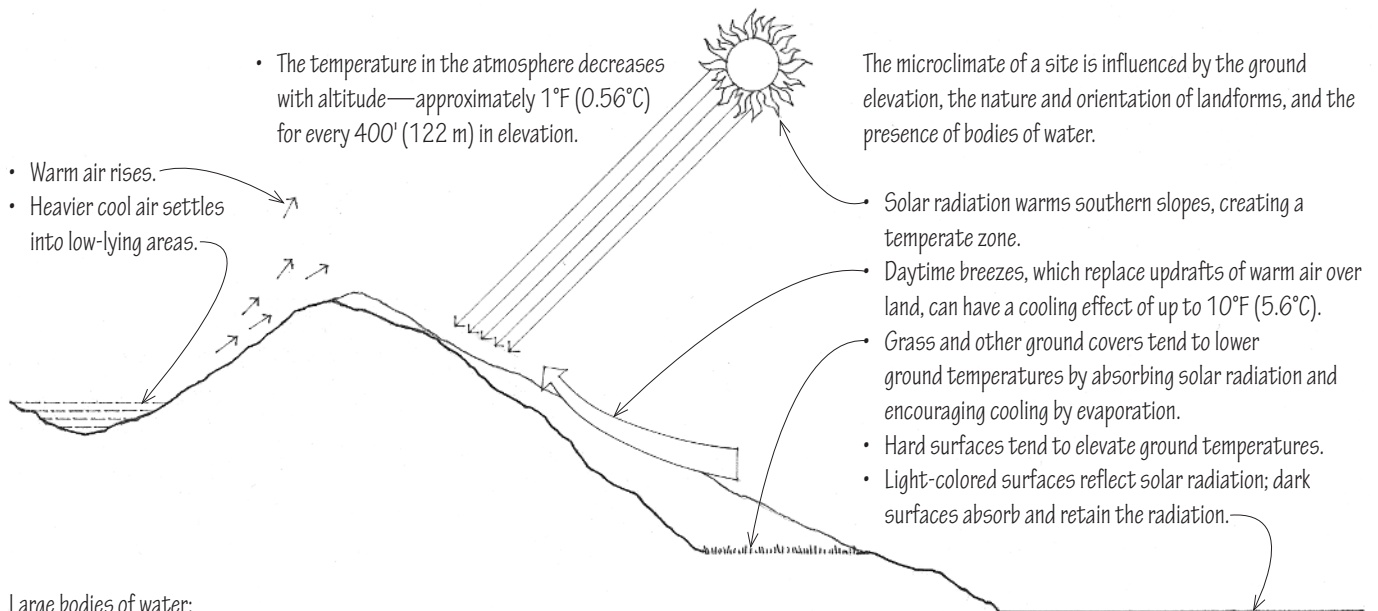

The microclimate of a site is influenced by the ground elevation, the nature and orientation of landforms, and the presence of bodies of water.

- Solar radiation warms southern slopes, creating a temperate zone.
- Daytime breezes, which replace updrafts of warm air over land, can have a cooling effect of up to 10°F (5.6°C).
- Grass and other ground covers tend to lower ground temperatures by absorbing solar radiation and encouraging cooling by evaporation.
- Hard surfaces tend to elevate ground temperatures.
- Light-colored surfaces reflect solar radiation; dark surfaces absorb and retain the radiation.

Large bodies of water:

- Act as heat reservoirs and moderate variations in local temperature;
- Are generally cooler than land during the day and warmer at night, generating offshore breezes;
- Are generally warmer than land in winter and cooler in summer.
- In hot-dry climates, even small bodies of water are desirable, both psychologically and physically, for their evaporative cooling effect.

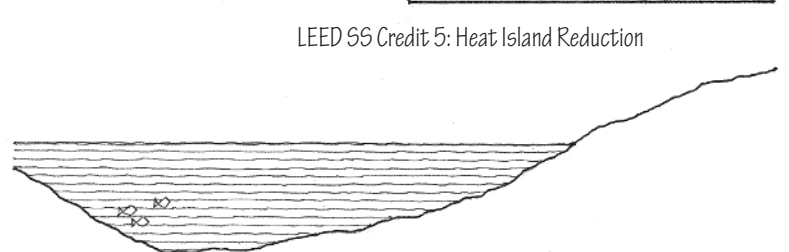

CSI MasterFormat 31 10 00: Site Clearing
 CSI MasterFormat 31 20 00: Earth Moving
 CSI MasterFormat 32 70 00: Wetlands

1.18 PLANT MATERIALS

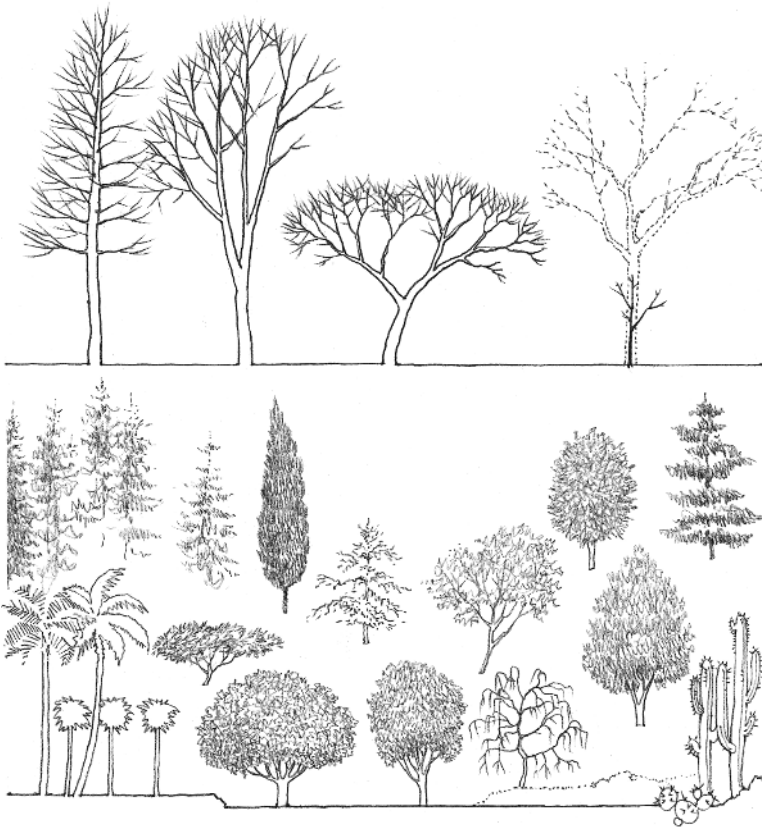

LEED SS Credit 4: Rainwater Management
LEED SS Credit 5: Heat Island Reduction
LEED WE Credit 1: Outdoor Water Use Reduction

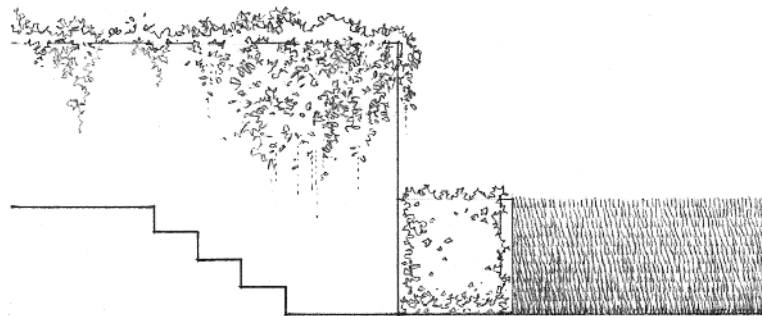
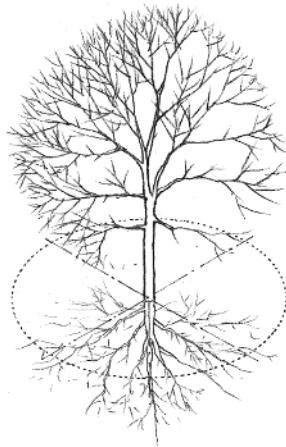

Plant materials provide aesthetic as well as functional benefits in conserving energy, framing or screening views, moderating noise, retarding erosion, and visually connecting a building to its site. Factors to consider in the selection and use of plant materials in landscaping include the:

- Tree structure and shape
 - Seasonal density, texture, and color of foliage
 - Speed or rate of growth
 - Mature height and spread of foliage
 - Requirements for soil, water, sunlight, and temperature range
 - Depth and extent of the root structure
-
- Trees and other plant life adapt their forms to the climate.
-
- Existing healthy trees and native plant materials should be preserved whenever possible. During construction and when regrading a site, existing trees should be protected for an area equal to the diameter of their crowns. The root systems of trees planted too close to a building may disturb the foundation system. Root structures can also interfere with underground utility lines.
 - To support plant life, soil must be able to absorb moisture, supply the appropriate nutrients, be capable of aeration, and be free of concentrated salts.

Grass and other ground covers:

- Can reduce air temperature by absorbing solar radiation and encouraging cooling by evaporation;
 - Aid in stabilizing soil embankments and preventing erosion;
 - Increase the permeability of soil to air and water.
-
- Vines can reduce the heat transmission through a sunlit wall by providing shade and cooling the immediate environment by evaporation.

Trees affect the immediate environment of a building in the following ways:

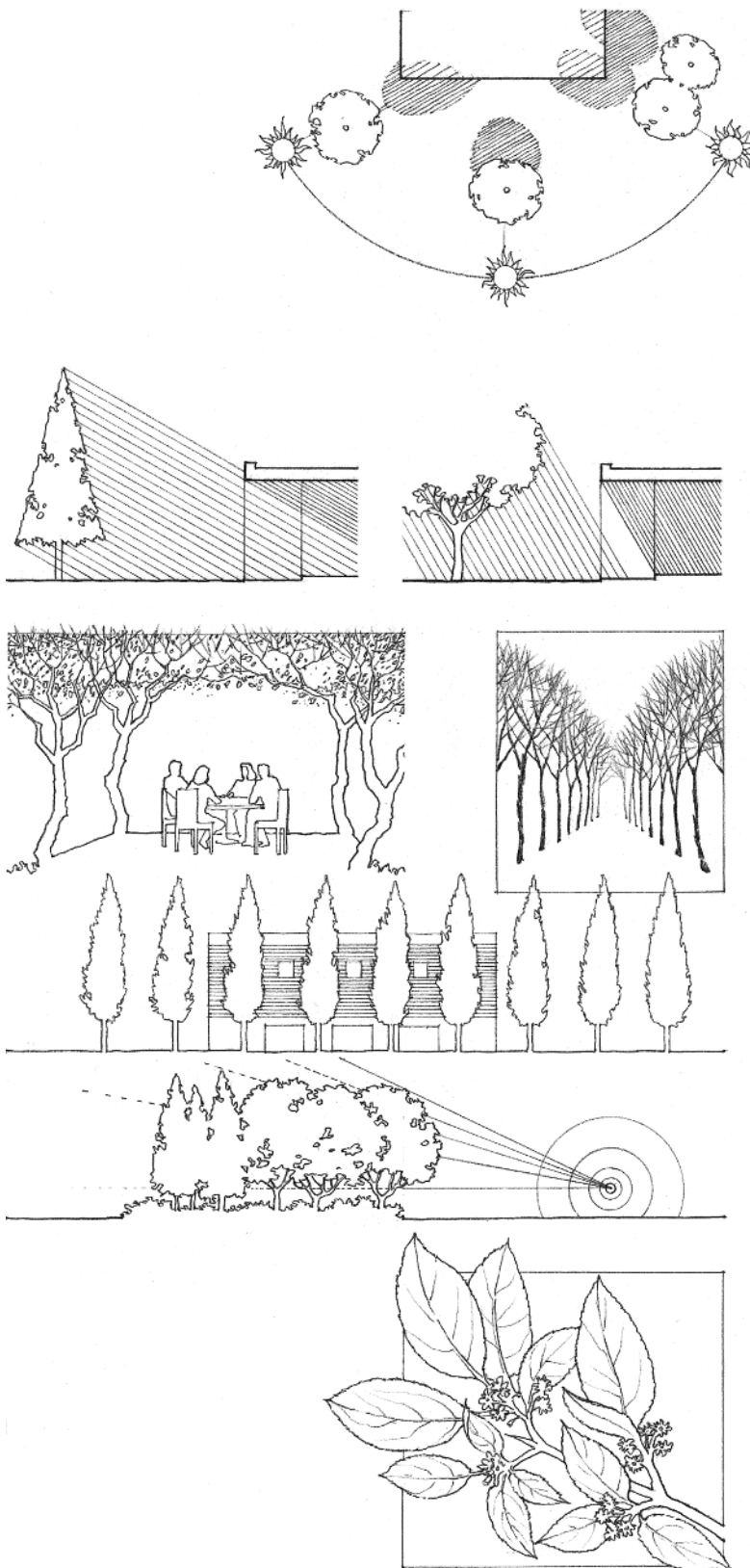

Providing Shade

The amount of solar radiation obstructed or filtered by a tree depends on its:

- Orientation to the sun
- Proximity to a building or outdoor space
- Shape, spread, and height
- Density of foliage and branch structure
- Trees shade a building or outdoor space most effectively from the southeast during the morning and the southwest during the late afternoon when the sun has a low altitude and casts long shadows.
- South-facing overhangs provide more efficient shading during the midday period when the sun is high and casts short shadows.
- Deciduous trees provide shade and glare protection during the summer and allow solar radiation to penetrate through their branch structures during the winter.
- Evergreens provide shade throughout the year and help reduce snow glare during the winter.

Serving as Windbreak

- Evergreens can form effective windbreaks and reduce heat loss from a building during the winter.
- The foliage of plant materials reduces wind-blown dust.

Defining Space

- Trees can shape outdoor spaces for activity and movement.

Directing or Screening Views

- Trees can frame desirable views.
- Trees can screen undesirable views and provide privacy for outdoor spaces.

Attenuating Sound

- A combination of deciduous and evergreen trees is most effective in intercepting and attenuating airborne sound, especially when combined with earth mounds.

Improving Air Quality

- Trees trap particulate matter on their leaves, which is then washed to the ground during rainfall.
- Leaves can also assimilate gaseous and other pollutants.
- Photosynthetic process can metabolize fumes and other odors.

Stabilizing Soil

- The root structures of trees aid in stabilizing soil, increasing the permeability of the soil to water and air, and preventing erosion.

1.20 SOLAR RADIATION

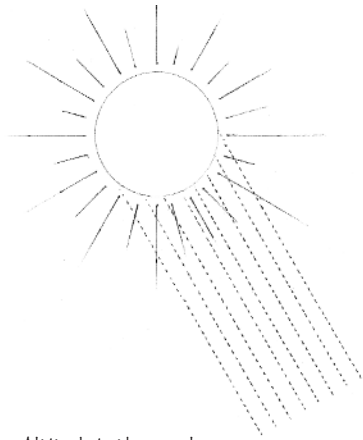

The location, form, and orientation of a building and its spaces should take advantage of the thermal, hygienic, and psychological benefits of sunlight. Solar radiation, however, may not always be beneficial, depending on the latitude and climate of the site. In planning the design of a building, the objective should be to maintain a balance between underheated periods when solar radiation is beneficial and overheated periods when radiation should be avoided.

The path of the sun through the sky varies with the seasons and the latitude of a building site. The range of solar angles for a specific site should be obtained from a weather almanac or service bureau before calculating the potential solar heat gain and shading requirements for a building design.

• Altitude is the angular elevation of the sun above the horizon.

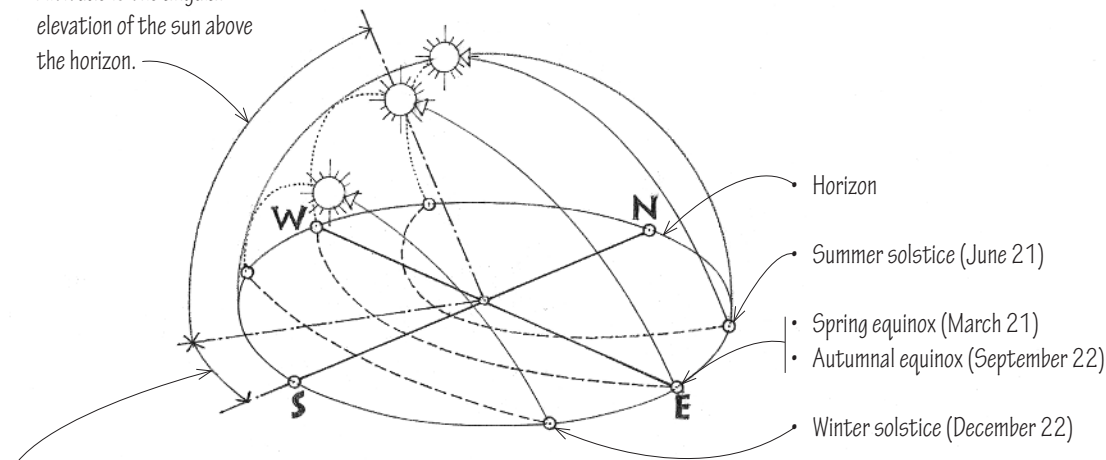

• Azimuth is the angle of horizontal deviation, measured clockwise, of a bearing from a standard south direction.

Solar Path Diagram

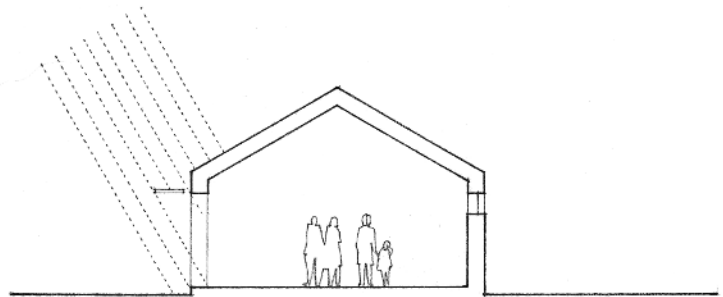

Representative Solar Angles

North Latitude	Representative City	Altitude at Noon		Azimuth at Sunrise & Sunset*	
		Dec. 22	Mar. 21/Sept. 22	Dec. 22	June 21
48°	Seattle	18°	42°	54°	124°
44°	Toronto	22°	46°	56°	122°
40°	Denver	26°	50°	58°	120°
36°	Tulsa	30°	54°	60°	118°
32°	Phoenix	34°	58°	62°	116°

*Azimuth is east of south for sunrise, and west of south for sunset.

The following are recommended forms and orientations for isolated buildings in different climatic regions. The information presented should be considered along with other contextual and programmatic requirements.

Cool Regions

Minimizing the surface area of a building reduces exposure to low temperatures.

- Maximize absorption of solar radiation.
- Reduce radiant, conductive, and evaporative heat loss.
- Provide wind protection.

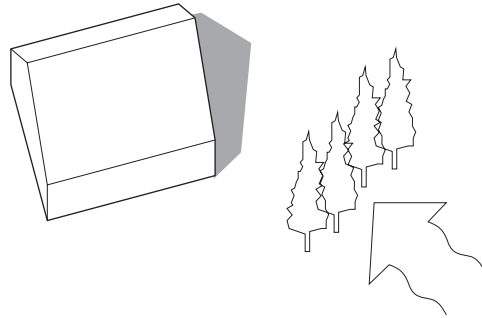

Temperate Regions

Elongating the form of a building along the east-west axis maximizes south-facing walls.

- Minimize east and west exposures, which are generally warmer in summer and cooler in winter than southern exposures.
- Balance solar heat gain with shade protection on a seasonal basis.
- Encourage air movement in hot weather; protect against wind in cold weather.

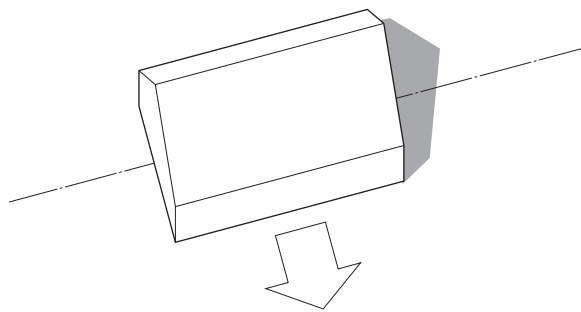

Hot-Arid Regions

Building forms should enclose courtyard spaces.

- Reduce solar and conductive heat gain.
- Promote cooling by evaporation using water features and plantings.
- Provide solar shading for windows and outdoor spaces.

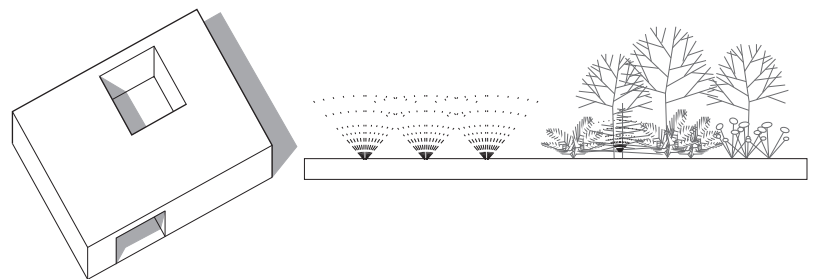

Hot-Humid Regions

Building form elongated along the east-west axis minimizes east and west exposures.

- Reduce solar heat gain.
- Utilize wind to promote cooling by evaporation.
- Provide solar shading for windows and outdoor spaces.

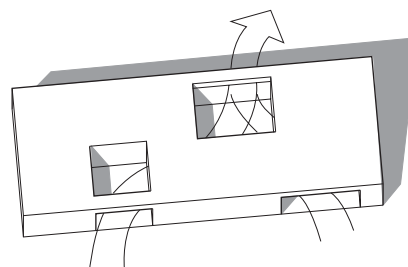

1.22 PASSIVE SOLAR DESIGN

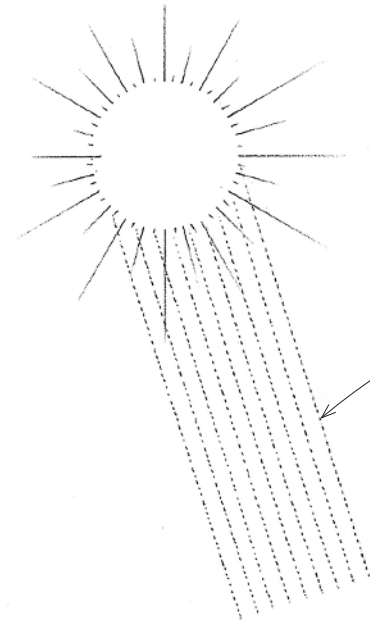

Passive solar heating refers to using solar energy to heat the interior spaces of a building without relying on mechanical devices that require additional energy. Passive solar systems rely instead on the natural heat transfer processes of conduction, convection, and radiation for the collection, storage, distribution, and control of solar energy.

The solar constant is the average rate at which radiant energy from the sun is received by the earth, equal to 430 Btu/ft²/hour (1353 W/m²/hr), used in calculating the effects of solar radiation on buildings.

There are two essential elements in every passive solar system:

1. Equator-facing glass or transparent plastic for solar collection.
 - Area of glazing should be 30% to 50% of floor area in cold climates and 15% to 25% of floor area in temperate climates, depending on average outdoor winter temperature and projected heat loss.
 - Glazing material should be resistant to the degradation caused by the ultraviolet rays of the sun.
 - Double- or triple-glazing and insulation are required to minimize nighttime heat loss.
 2. A thermal mass for heat collection, storage, and distribution, oriented to receive maximum solar exposure.
 - Thermal storage materials include concrete, brick, stone, tile, rammed earth, sand, and water or other liquid. Phase-change materials, such as eutectic salts and paraffins, are also feasible.
 - Concrete: 12" to 18" (305 to 455)
 - Brick: 10" to 14" (255 to 355)
 - Adobe: 8" to 12" (200 to 305)
 - Water: 6" (150) or more
 - Dark-colored surfaces absorb more solar radiation than light-colored surfaces.
- Vents, dampers, movable insulation panels, and shading devices can assist in balancing heat distribution.

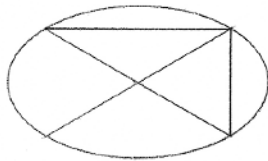
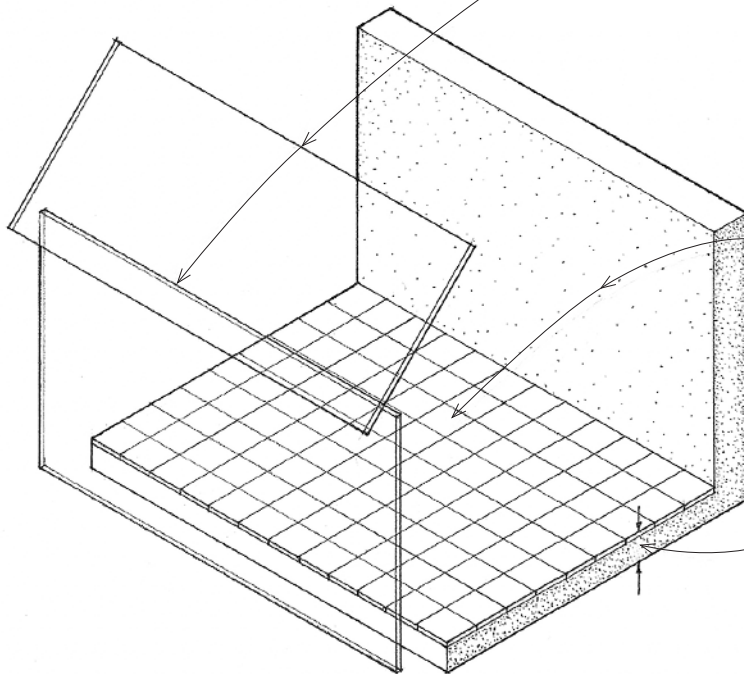

LEED EA Credit 5: Renewable Energy

Based on the relationship between the sun, the interior space, and the heat collection system, there are three ways in which passive solar heating can be accomplished: direct gain, indirect gain, and isolated gain.

Direct Gain

Direct gain systems collect heat directly within an interior space. The surface area of the storage mass, which is incorporated into the space, should be 50% to 66% of the total surface area of the space. During the cooling season, operable windows and walls are used for natural or induced ventilation.

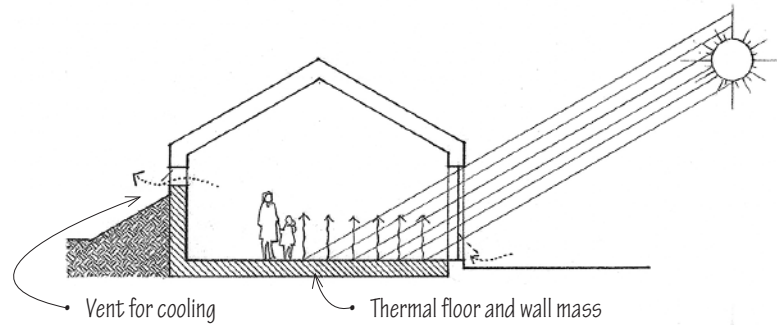

Indirect Gain

Indirect gain systems control heat gain at the exterior skin of a building. The solar radiation first strikes the thermal mass, either a concrete or masonry Trombe wall, or a drumwall of water-filled barrels or tubes, which is located between the sun and the living space. The absorbed solar energy moves through the wall by conduction and then to the space by radiation and convection.

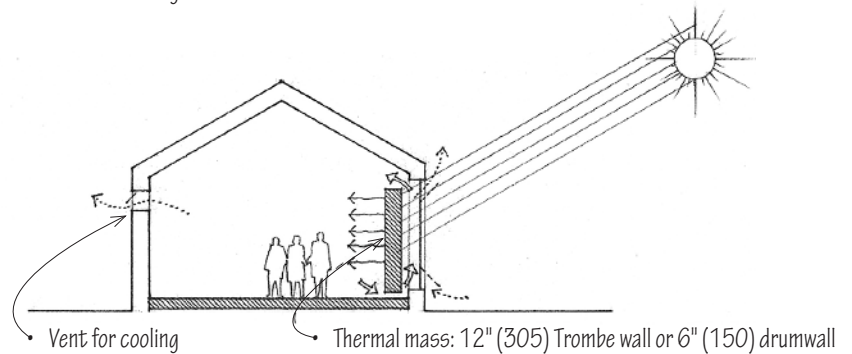

Sunspace

A sunroom or solarium is another medium for indirect heat gain. The sunspace, having a floor of high thermal mass, is separated from the main living space by a thermal storage wall from which heat is drawn as needed. For cooling, the sunspace can be vented to the exterior.

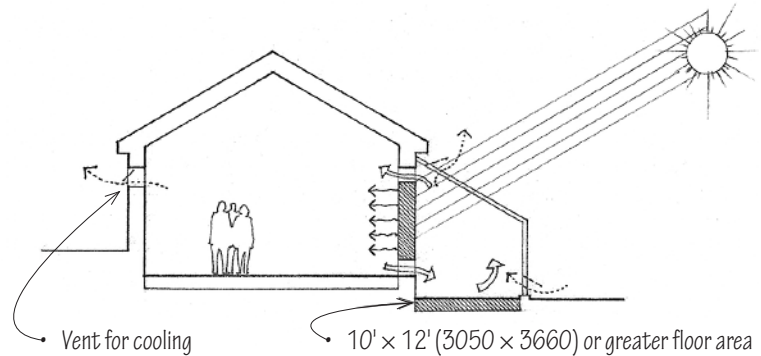

Roof Pond

Another form of indirect gain is a roof pond that serves as a liquid mass for absorbing and storing solar energy. An insulating panel is moved over the roof pond at night, allowing the stored heat to radiate downward into the space. In summer, the process is reversed to allow internal heat absorbed during the day to radiate to the sky at night.

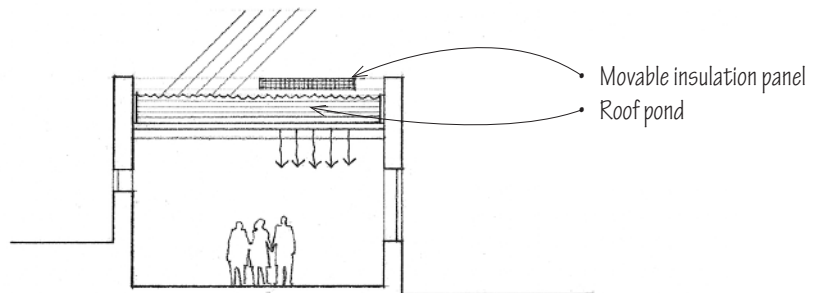

Isolated Gain

Isolated gain systems collect and store solar radiation away from the space to be heated. As air or water in a collector is warmed by the sun, it rises to the served space or is stored in the thermal mass until needed. Simultaneously, cooler air or water is pulled from the bottom of the thermal storage, creating a natural convection loop.

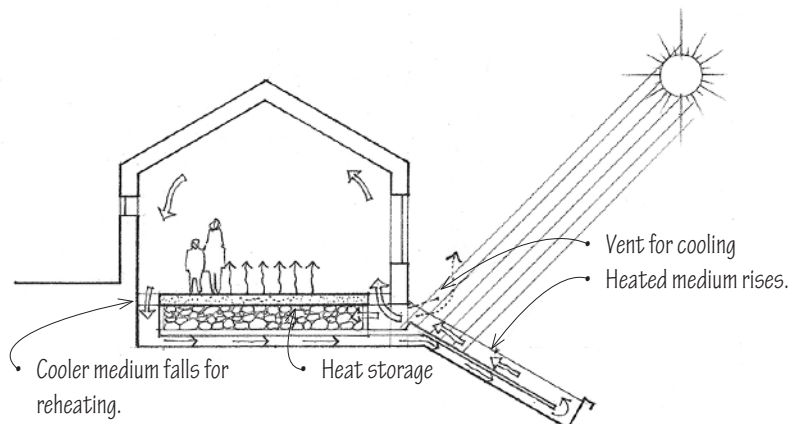

1.24 SOLAR SHADING

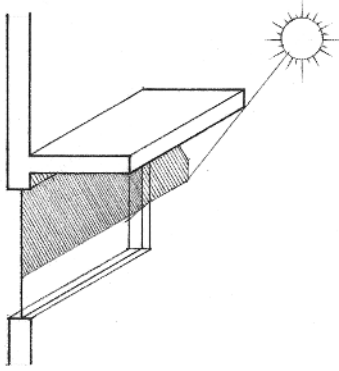

- Horizontal overhangs are most effective when they have southern orientations.

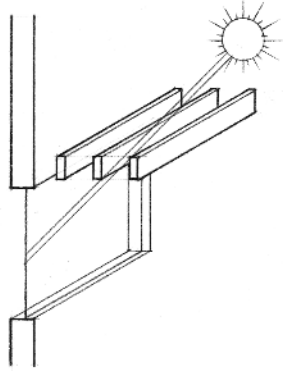

- Horizontal louvers parallel to a wall permit air circulation near the wall and reduce conductive heat gain.
- Louvers may be operated manually or controlled automatically with time or photoelectric controls to adapt to the solar angle.

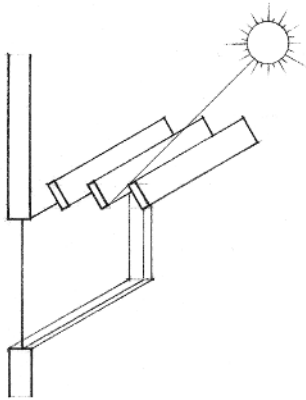

- Slanted louvers provide more protection than those parallel to a wall.
- Angle varies according to the range of solar angles.

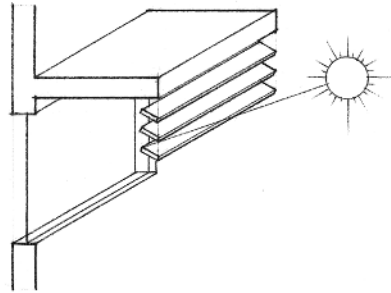

- Louvers hung from a solid overhang protect against low sun angles.
- Louvers may interfere with view.

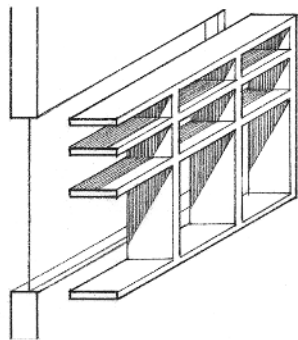

- Eggcrates combine the shading characteristics of horizontal and vertical louvers and have a high shading ratio.
- Eggcrates, sometimes referred to as brise-soleil, are very efficient in hot climates.

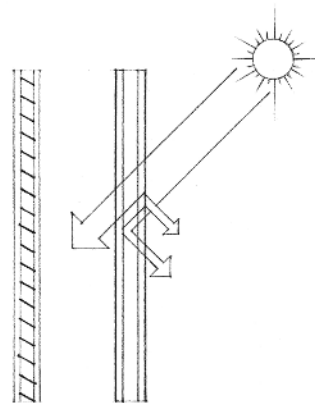

- Solar blinds and screens can provide up to a 50% reduction in solar radiation, depending on their reflectivity.
- Heat-absorbing glass can absorb up to 40% of the radiation reaching its surface.

Shading devices shield windows and other glazed areas from direct sunlight in order to reduce glare and excessive solar heat gain in warm weather. Their effectiveness depends on their form and orientation relative to the solar altitude and azimuth for the time of day and season of the year. Exterior devices are more efficient than those located within interior spaces because they intercept solar rays before they can reach an exterior wall or window.

Illustrated are basic types of solar shading devices. Their form, orientation, materials, and construction may vary to suit specific situations. Their visual qualities of pattern, texture, and rhythm, and the shadows they cast, should be considered when designing the facades of a building.

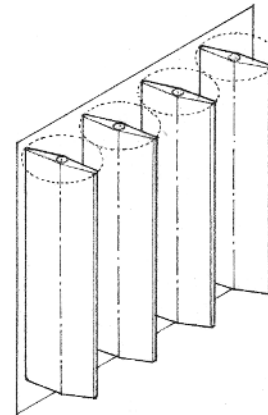

- Vertical louvers are most effective for eastern or western exposures.
- Louvers may be operated manually or controlled automatically with time or photoelectric controls to adapt to solar angle.
- Separation from wall reduces conductive heat gain.

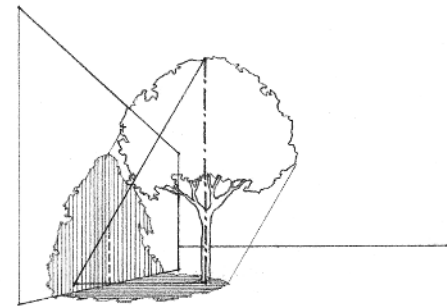

- Trees and adjacent structures may provide shade depending on their proximity, height, and orientation.

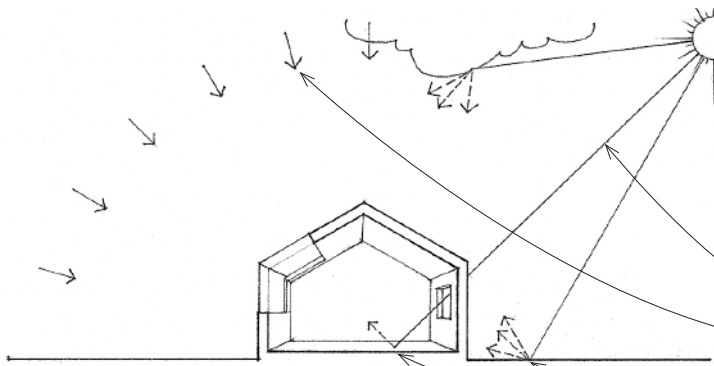

Solar radiation provides not only heat but also light for the interior spaces of a building. This daylight has psychological benefits as well as practical utility in reducing the amount of energy required for artificial lighting. While intense, direct sunlight varies with the time of day, from season to season, and from place to place, it can be diffused by cloud cover, haze, and precipitation, and reflected from the ground and other surrounding surfaces.

- Direct sunlight
- Skylight reflected and diffused by air molecules.
- External reflectance from the ground and adjacent structures.
- Internal reflectance from room surfaces.

- North-facing windows let in soft, diffuse skylight.

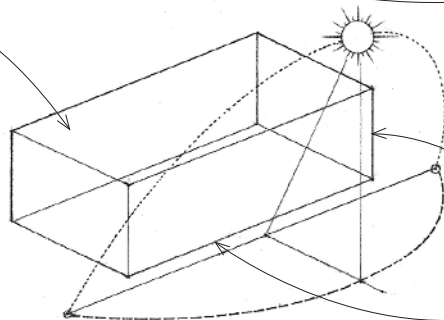

The quantity and quality of daylighting in a space are determined by the size and orientation of its window openings, transmittance of the glazing, reflectance of room surfaces and outdoor surfaces, and obstructions of overhangs and nearby trees.

- East- and west-facing windows require shading devices to avoid the bright early-morning and late-afternoon sun.
- South-facing windows are ideal sources of daylight if horizontal shading devices can control excessive solar radiation and glare.

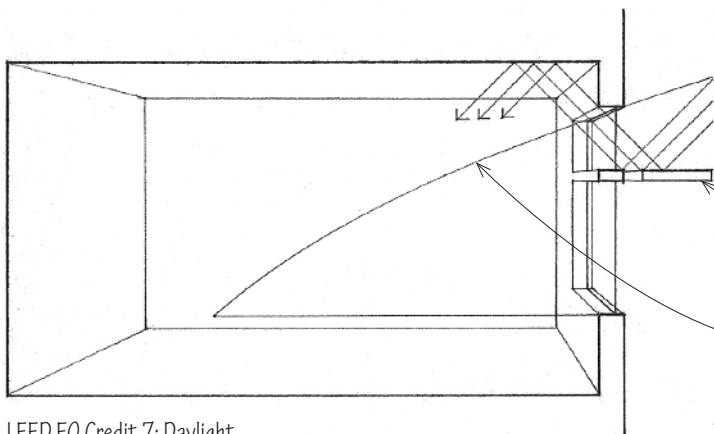

The level of illumination provided by daylight diminishes as it penetrates an interior space. Generally, the larger and higher a window is, the more daylight will enter a room.

- Light shelves shade glazing from direct sunlight while reflecting daylight onto the ceiling of a room. A series of parallel, opaque white louvers can also provide solar shading and reflect diffused daylight into the interior.
- A useful rule of thumb is that daylighting can be effective for task illumination up to a depth of twice the height of a window.

LEED EQ Credit 7: Daylight

- The ceiling and back wall of a space are more effective than the side walls or the floor in the reflection and distribution of daylight; light-colored surfaces reflect and distribute light more efficiently, but large areas of shiny surfaces can cause glare.
- Skylights with translucent glazing can effectively daylight a space from above without excessive heat gain.
- Roof monitors are another means of reflecting daylight into a space.

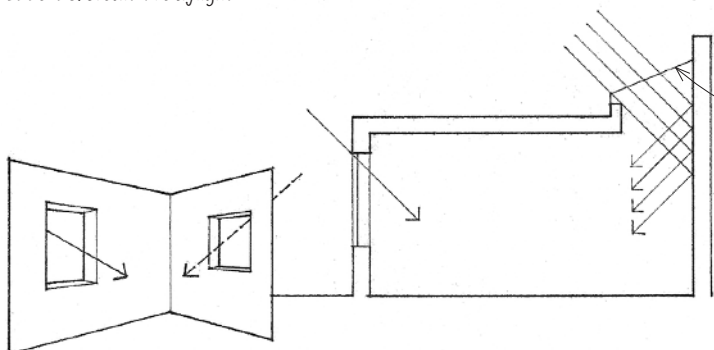

- For the most balanced daylighting, allow daylight to penetrate a space from at least two directions.

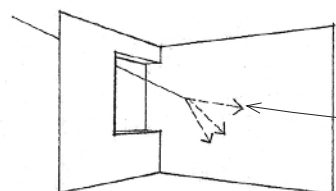

Excessive brightness ratios can lead to glare and impairment of visual performance. Glare can be controlled by the use of shading devices, the proper orientation of task surfaces, and allowing daylight to enter a space from at least two directions.

- Place windows adjacent to side walls for additional reflectance and illumination.

1.26 PRECIPITATION

The amount of annual and seasonal precipitation expected for a building site should influence the design and construction of the roof structure of a building, the choice of building materials, and the detailing of its exterior wall assemblies. Furthermore, the runoff of rain and melting snow from constructed roof areas and paved surfaces increases the amount of stormwater that must be drained from the site.

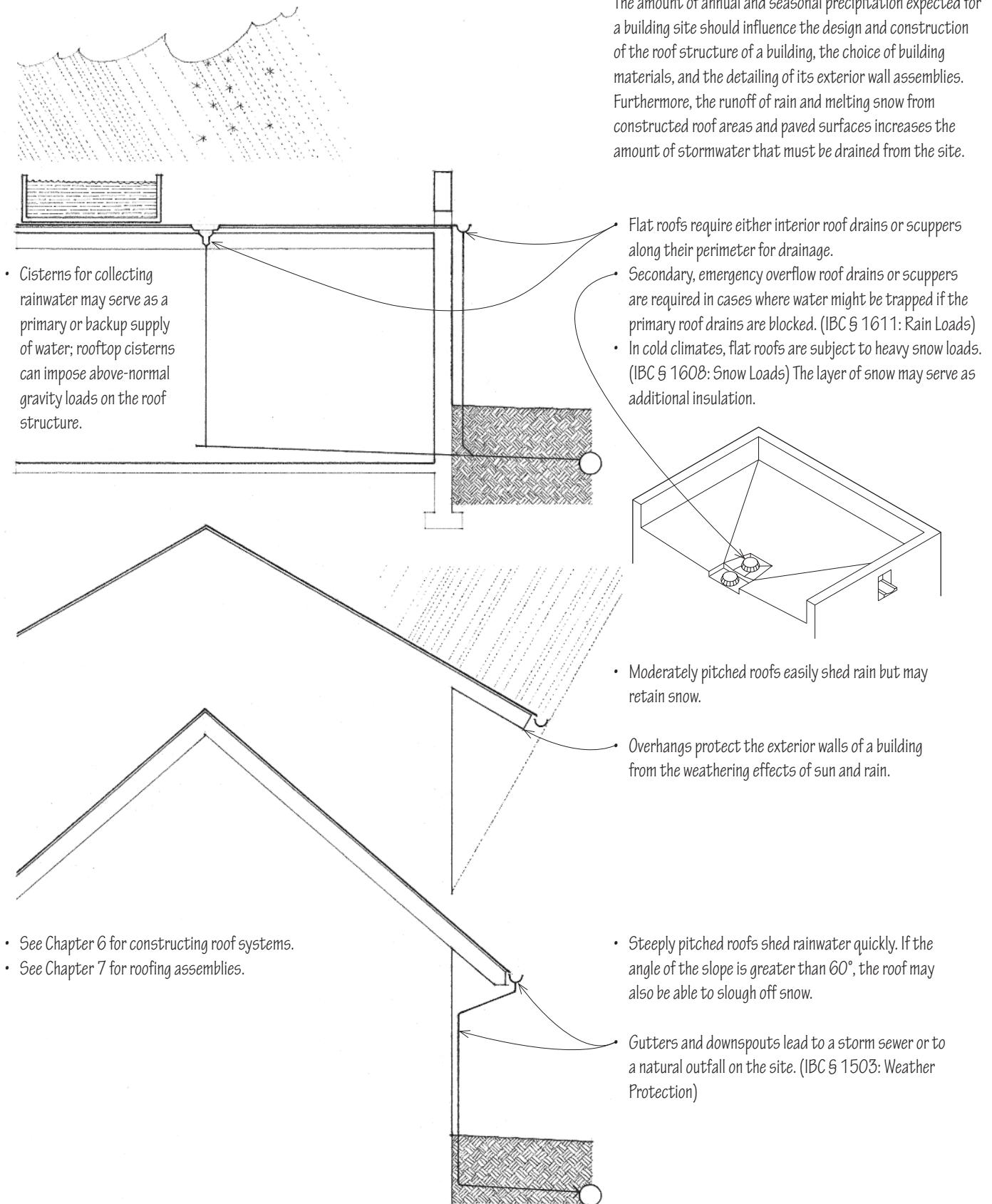

Development of a site can disrupt the existing drainage pattern and create additional water flow from constructed roof areas and paved surfaces. Limiting disruption of a site's natural water hydrology and promoting infiltration by such means as pervious paving and vegetated roofs is always advisable and, in many cases, mandated by code. Site drainage is necessary to prevent erosion and the collection of excess surface water or groundwater resulting from new construction.

There are two basic types of site drainage: subsurface and surface drainage systems. Subsurface drainage consists of an underground network of piping for conveying groundwater to a point of disposal, as a storm sewer system or a natural outfall at a lower elevation on the site. Excess groundwater can reduce the load-carrying capacity of a foundation soil and increase the hydrostatic pressure on a building foundation. Waterproofing is required for basement structures situated close to or below the water table of a site.

Surface drainage refers to the grading and surfacing of a site in order to divert rain and other surface water into natural drainage patterns or a municipal storm sewer system. A holding pond may be necessary when the amount of surface runoff exceeds the capacity of the storm sewer system.

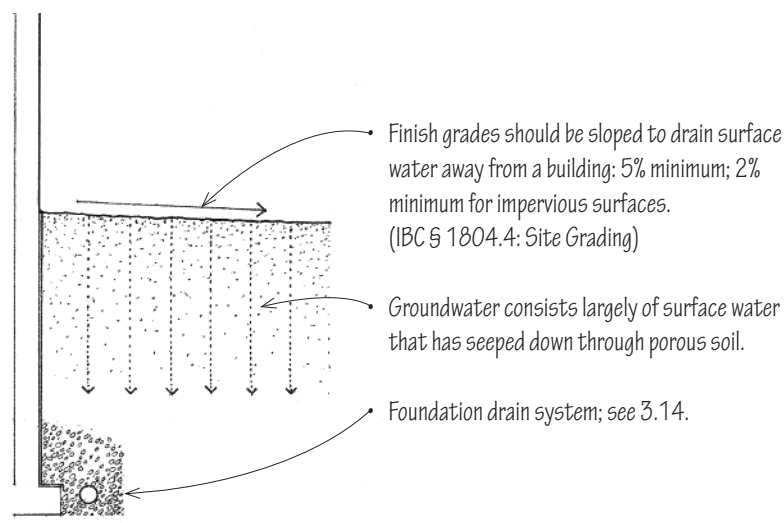

Surface Drainage Slopes

- Grass lawns and fields: 1.5% to 10% recommended.
- Paved parking areas: 2% to 3% recommended.

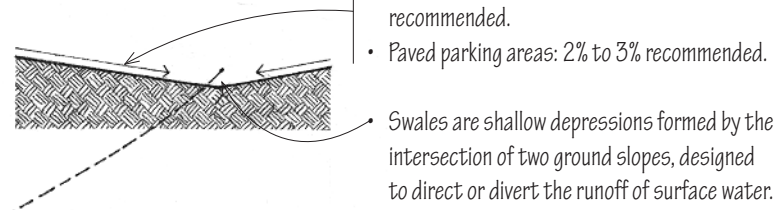

- Grass swales: 1.5% to 2% recommended.
- Paved swales: 4% to 6% recommended.
- Area drains collect surface water from a basement floor or paved area.
- Dry wells are drainage pits lined with gravel or rubble to receive surface water and allow it to percolate away to absorbent earth underground.

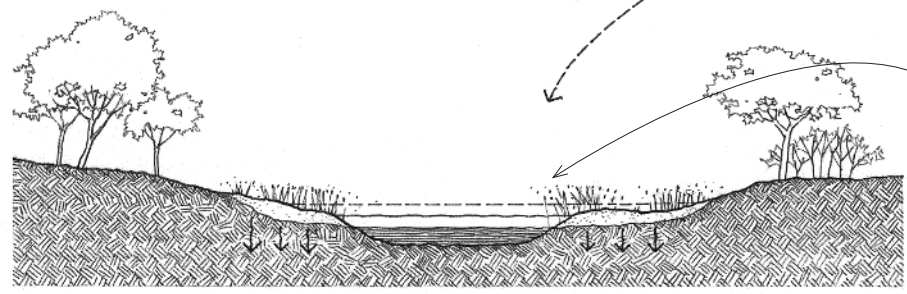
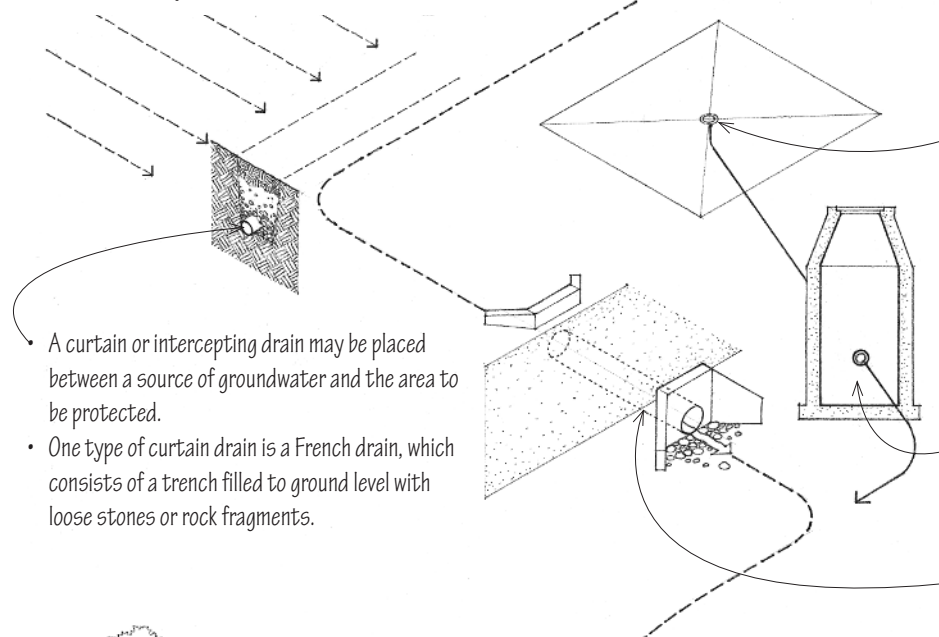

LEED SS Credit 4: Rainwater Management

1.28 WIND

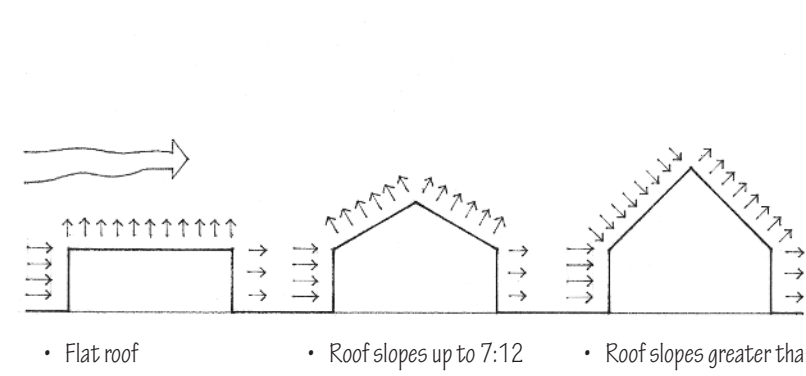
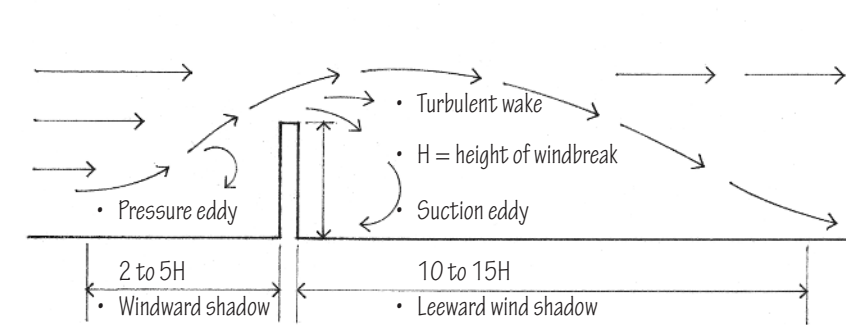
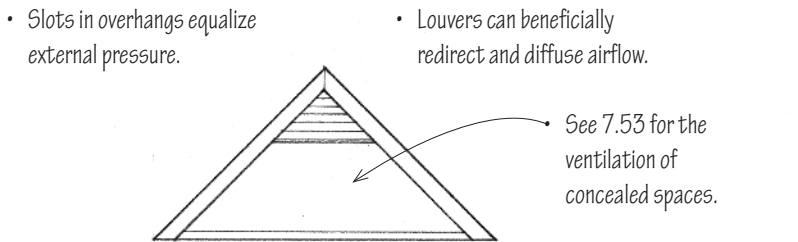
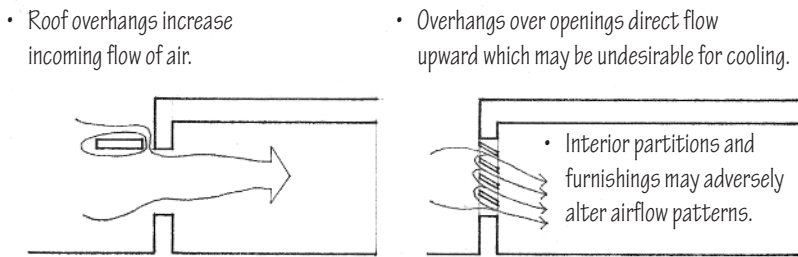
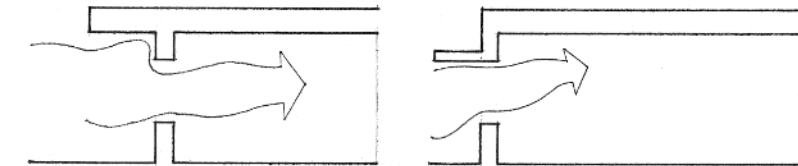
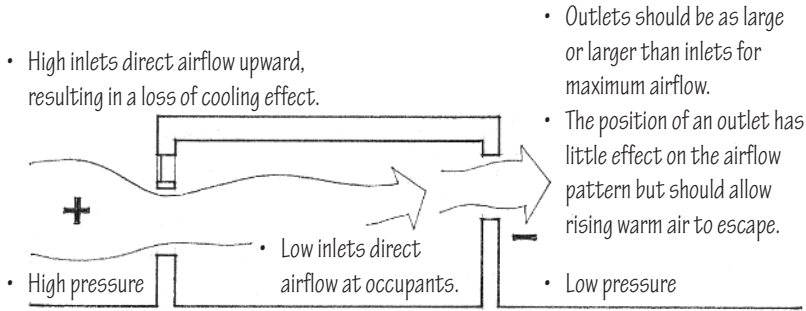

The direction and velocity of prevailing winds are important site considerations in all climatic regions. The seasonal and daily variations in wind should be carefully considered in evaluating its potential for ventilating interior spaces and outdoor courtyards in warm weather, causing heat loss in cold weather, and imposing lateral loads on a building structure.

Wind-induced ventilation of interior spaces aids in the air exchange necessary for health and odor removal. In hot weather, and especially in humid climates, ventilation is beneficial for convective or evaporative cooling. Natural ventilation also reduces the energy required by mechanical fans and equipment. (LEED EQ Credit 1: Enhanced Indoor Air Quality Strategies)

The movement of air through a building is generated by differences in air pressure as well as temperature. The resulting patterns of airflow are affected more by building geometry and orientation than by airspeed.

The ventilation of concealed roof and crawl spaces is required to remove moisture and control condensation. In hot weather, attic ventilation can also reduce overhead radiant heat gain.

In cold climates, a building should be buffered against chilling winds to reduce infiltration into interior spaces and lower heat loss. A windbreak may be in the form of an earth berm, a garden wall, or a dense stand of trees. Windbreaks reduce wind velocity and produce an area of relative calm on their leeward side. The extent of this wind shadow depends on the height, depth, and density of the windbreak, its orientation to the wind, and the wind velocity.

• A partially penetrable windscreen creates less pressure differential, resulting in a large wind shadow on the leeward side of the screen.

The structure, components, and cladding of a building must be anchored to resist wind-induced overturning, uplift, and sliding. Wind exerts positive pressure on the windward surfaces of a building and on windward roof surfaces having a slope greater than 30°. Wind exerts negative pressure or suction on the sides and leeward surfaces and normal to windward roof surfaces having a slope less than 30°. See 2.15 for more information on wind forces.

Sound requires a source and a path. Undesirable exterior sounds or noise may be caused by vehicular traffic, aircraft, and other machinery. The sound energy they generate travels through the air outward from the source in all directions in a continuously expanding wave. This sound energy, however, lessens in intensity as it disperses over a wide area. To reduce the impact of exterior noise, therefore, the first consideration should be distance—locating a building as far from the noise source as possible. When the location or dimensions of a site do not make this possible, then the interior spaces of a building may be screened from the noise source in the following ways.

- Use building zones where noise can be tolerated, for example, mechanical, service, and utility areas, as a buffer.
- Employ building materials and construction assemblies designed to reduce the transmission of airborne and structure-borne sound.
- Orient door and window openings away from the sources of undesirable noise.
- Place physical mass, such as earth berms, between the noise source and the building.
- Utilize dense plantings of trees and shrubs, which can be effective in diffusing or scattering sound.
- Plant grass or other ground cover, which is more absorptive than the hard, reflective surfaces of pavements.

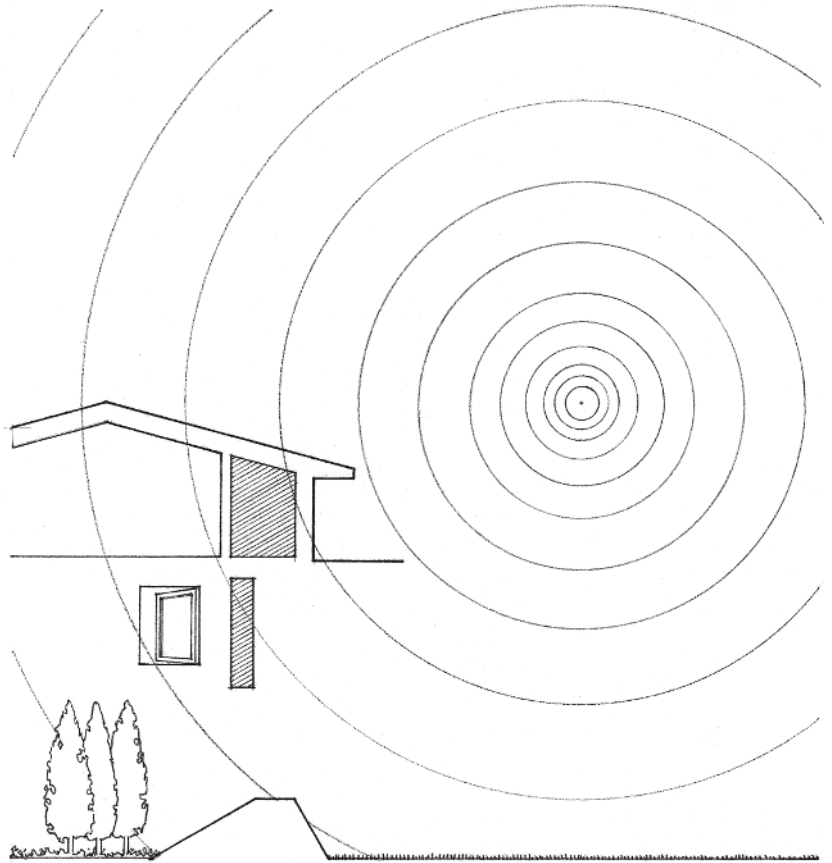

An important aspect of site planning is orienting the interior spaces of a building to the amenities and features of a site. Given the appropriate orientation, window openings in these spaces should be positioned not only to satisfy the requirements for natural light and ventilation but also to reveal and frame desirable views. Depending on the location of the site, these views may be close or distant in nature. Even when desirable views are nonexistent, a pleasant outlook can often be created within a building site through landscaping.

A window may be created within a wall in a number of ways, depending on the nature of the view and the way it is framed in the wall construction. It is important to note that the size and location of windows also affect the spatial quality and daylighting of a room, and the potential for heat loss or gain.

- South-facing windows can be effectively shaded while admitting daylight.
- North-facing windows are exposed to winter winds in cool climates.
- East- and west-facing windows are sources of overheating and are difficult to shade effectively.

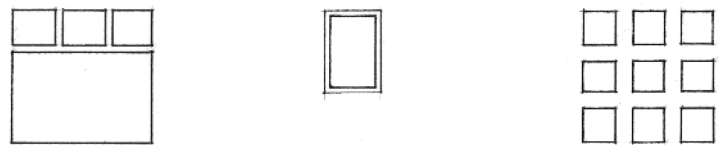
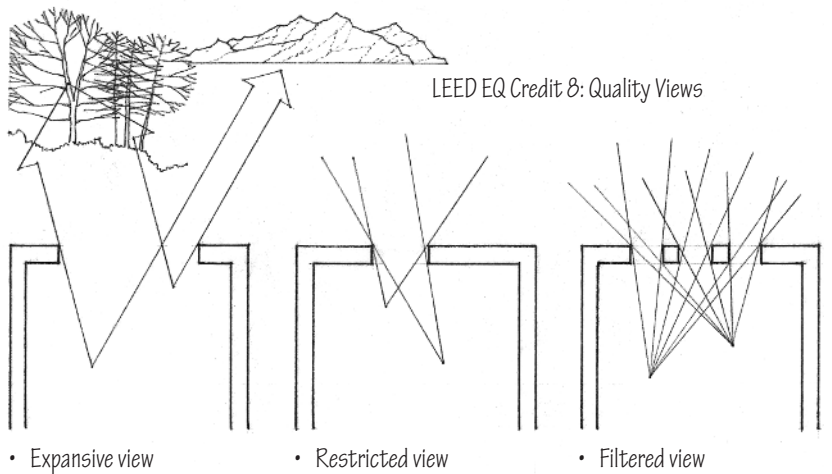

1.30 REGULATORY FACTORS

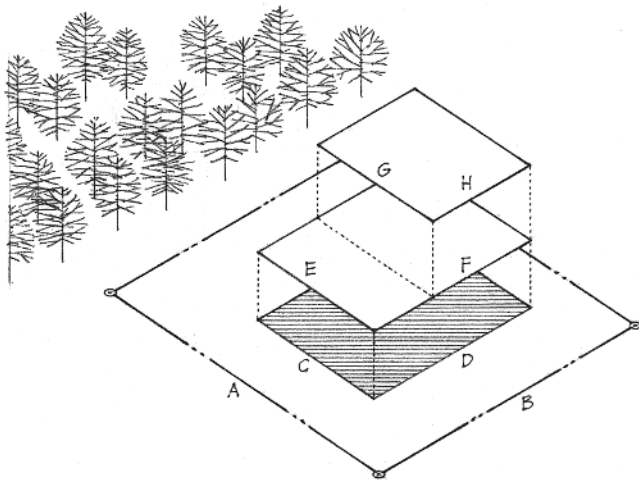

Zoning ordinances are enacted within a municipality or land-use district to manage growth, regulate land-use patterns, control building density, direct development to areas with adequate services and amenities, protect environmentally sensitive areas, and conserve open space.

For any single building site, a zoning ordinance will regulate both the types of activity that may occur on it and the location and bulk of the building or buildings constructed to house such activities. A special type of zoning ordinance is the Planned Unit Development, which allows a fairly large tract of land to be developed as a single entity for added flexibility in the placement, grouping, size, and use of structures.

It is important to understand how a zoning ordinance might constrain the allowable size and shape of a building. The bulk of a building is regulated directly by specifying various aspects of its size.

- Percentage of allowable lot coverage = $(C \times D) / (A \times B)$
- Percentage of allowable total floor area = $[(C \times D) + (E \times F) + (G \times H)] / (A \times B)$

- Percentage of allowable width or depth = C/A or D/B

- Required front, side, rear setbacks
- Buildable area

- Property lines

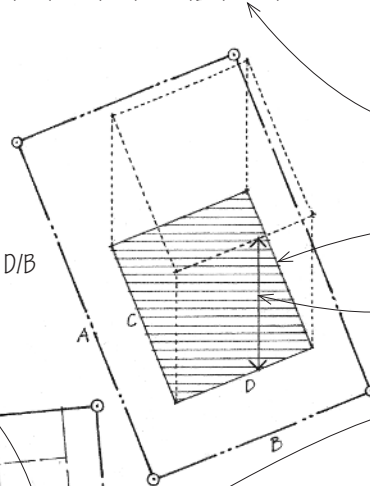

- How much of the land can be covered by a building structure and the total floor area that may be constructed are expressed as percentages of the lot area.
- The maximum width and depth a building may have are expressed as percentages of the dimensions of the site.
- Zoning ordinances also specify how tall the building structure can be.

The size and shape of a building are also controlled indirectly by specifying the minimum required distances from the structure to the property lines of the site in order to provide air, light, solar access, and privacy.

Existing easements and rights-of-way may further limit the buildable area of a site.

- An easement is a legal right held by one party to make limited use of the land of another, as for a right-of-way or for access to light and air.
- A right-of-way is a legal right granted to a single party or the public to traverse another's land, as for access to or the construction and maintenance of utility lines.

All of the above requirements, together with any restriction on type and density of use, define a three-dimensional envelope beyond which the volume of a building may not extend. Refer to the applicable zoning ordinance for specific requirements.

Exclusions to the general requirements of a zoning ordinance may exist in the form of exceptions or allowances. Exceptions to the normal setback requirements may be made for:

- Projections of architectural features such as roof overhangs, cornices, bay windows, and balconies.
- Accessory structures such as low-level decks, fences, and detached carports or garages.
- Precedents set by existing, neighboring structures.

Exceptions are often made for sloping sites, or for sites adjacent to public open spaces.

- Sloping roofs, chimneys, and other roof projections may be allowed to extend beyond the normal height limitation.
- The height limit may be directly related to the slope of a site.
- A reduction in the setback requirements may be made for sloping sites or for sites fronting on open space.

In order to provide adequate light, air, and space, and to enhance the streetscape and pedestrian environment, requirements may exist for:

- Open spaces accessible to the public (LEED SS Credit 3: Open Space).
- Additional setbacks if a structure rises above a certain height.
- Modulation of the facade of a building fronting a public space.
- Vehicular access and off-street parking.

Zoning ordinances may also contain requirements that apply only to specific use categories as well as procedures for requesting a variance from the regulations.

- Restrictive covenants are provisions in a deed that restrict the action of any party to it, as an agreement among property owners specifying the use to which a property can be put. Racial and religious restrictions are legally unenforceable.

Other regulatory instruments exist that affect the way buildings are sited and constructed. These statutes—commonly referred to as the building code—establish the relationship between:

- The type of occupancy a building houses.
- The fire-resistance rating of its structure and construction.
- The allowable height and floor areas of the building, and its separation from neighboring structures.

- See 2.08 for more information on building codes.

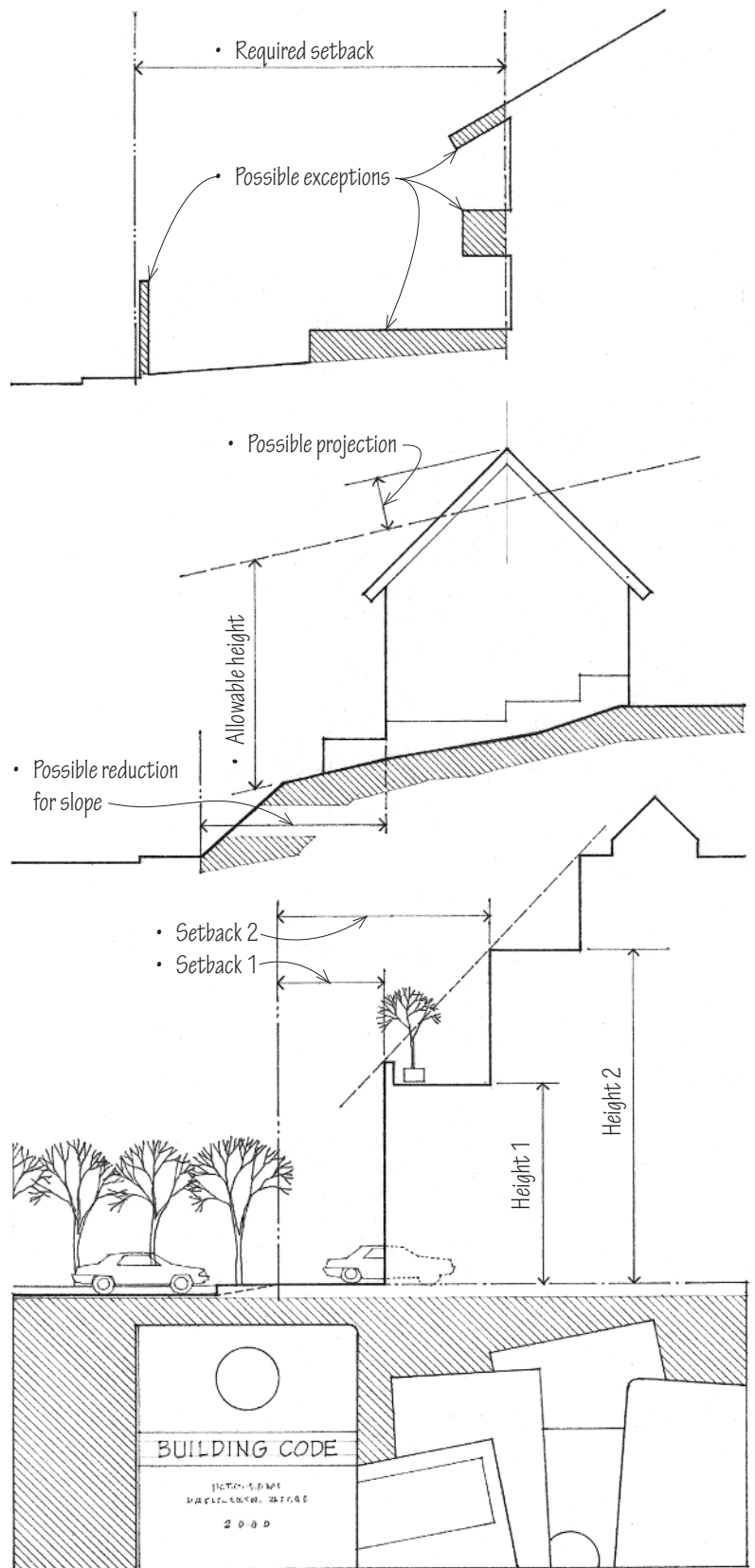

1.32 SITE ACCESS & CIRCULATION

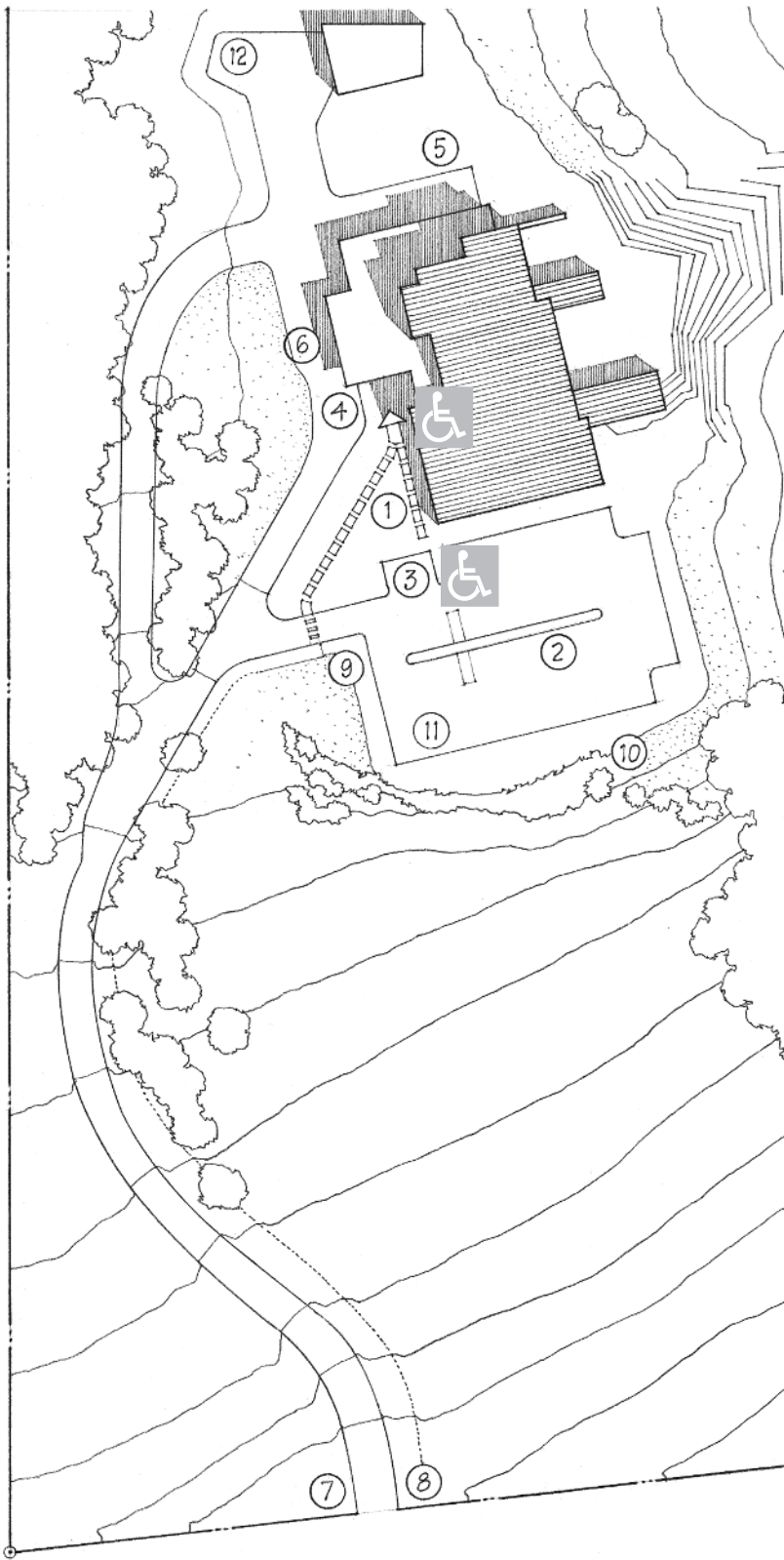

Providing for access and circulation for pedestrians, automobiles, and service vehicles is an important aspect of site planning, which influences both the location of a building on its site and the orientation of its entrances. Outlined here and on the following pages are fundamental criteria for estimating and laying out the space required for walkways, roadways, and surface parking.

1. Provide for safe and convenient pedestrian access and movement to building entrances from parking areas or public transit stops with minimal crossing of roadways.
2. Determine the number of parking spaces required by the zoning ordinance for the type of occupancy and total number of units or floor area of the building.
3. Determine the number of accessible parking spaces as well as curb cuts, ramps, and paths to accessible building entrances required by local, state, or federal law.
4. Provide loading zones for buses and other public transportation vehicles where applicable.
5. Separate service and truck loading areas from pedestrian and automobile traffic.
6. Furnish access for emergency vehicles such as fire trucks and ambulances.
7. Establish the required width and location of curb cuts and their proper distance from public street intersections.
8. Ensure clear sight lines for vehicles entering public roadways.
9. Plan for control of access to parking areas where required.
10. Provide space for landscaping; screening of parking areas may be required by zoning ordinance.
11. Slope paved walkways and parking areas for drainage.
12. Provide space for snow removal equipment in cold climates.

- Illustration adapted from the site plan for the Carré House, designed by Alvar Aalto.

- 7' 6" (2285) minimum overhead clearance
- Minimize conflicts with roadways and parking areas.
- Provide traction in areas subject to icy conditions.
- 0.5% minimum slope for drainage; 1.5% preferred.

Pedestrian Walks

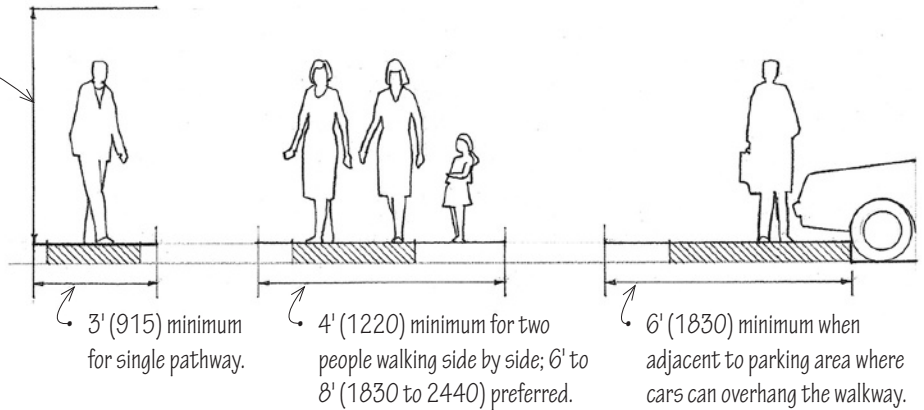

- Minimum of three risers per run of stairs.
- Handrails are required for stairs having four or more risers, or where icy conditions exist.

Exterior Stairs

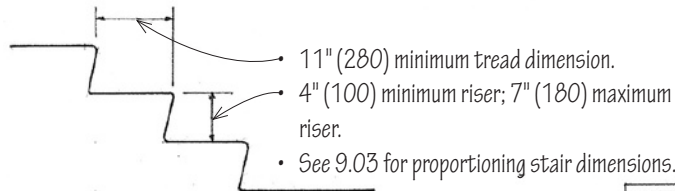

- Provide amenities, such as benches, trash containers, and lighting.

Bike Paths

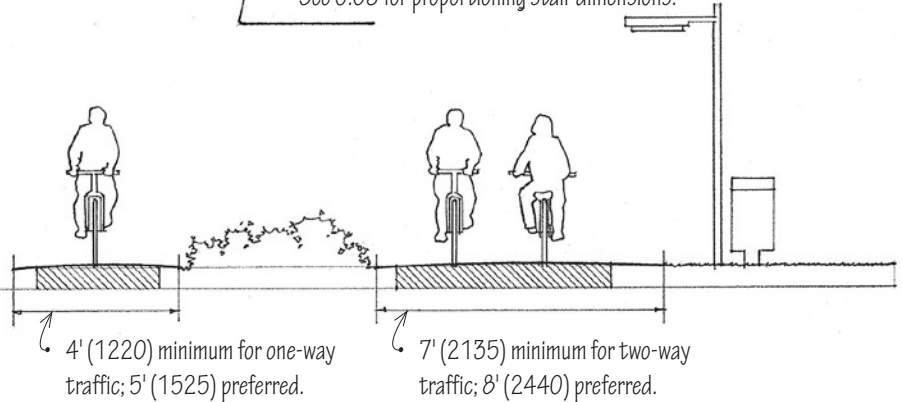

- Avoid surface irregularities that can impede wheelchair traffic.
- Provide tactile warning strips for the visually impaired at grade changes and hazardous vehicular areas.
- See A.03 for general ADA Accessibility Guidelines. (IBC Chapter 11: Accessibility)

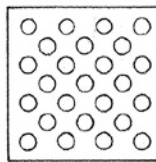

ADA Accessibility Guidelines

- Curb ramps are required wherever an accessible route crosses a curb.
- Surface of ramp should be stable, firm, and slip-resistant.
- Returned curbs are allowable where pedestrians would not normally walk across the ramp.

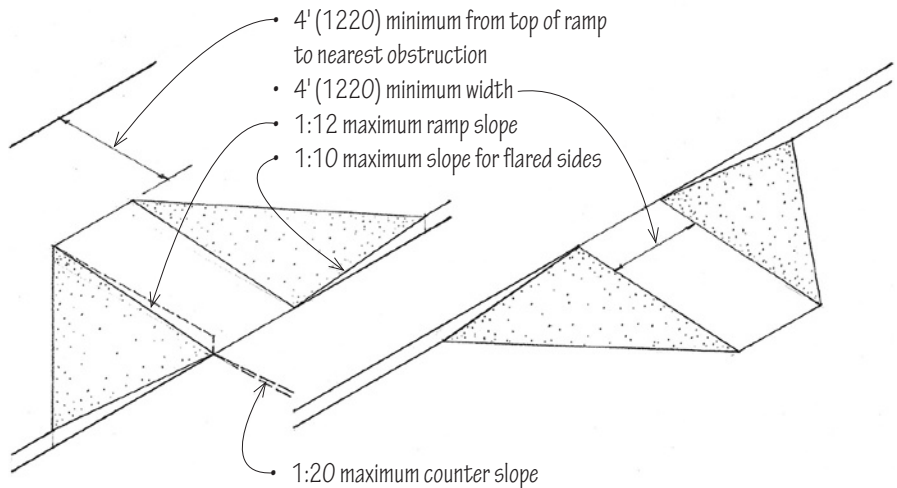
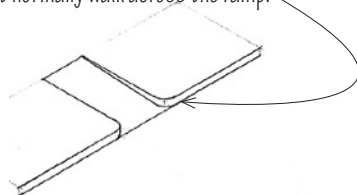

Curb Ramps

1.34 VEHICULAR CIRCULATION

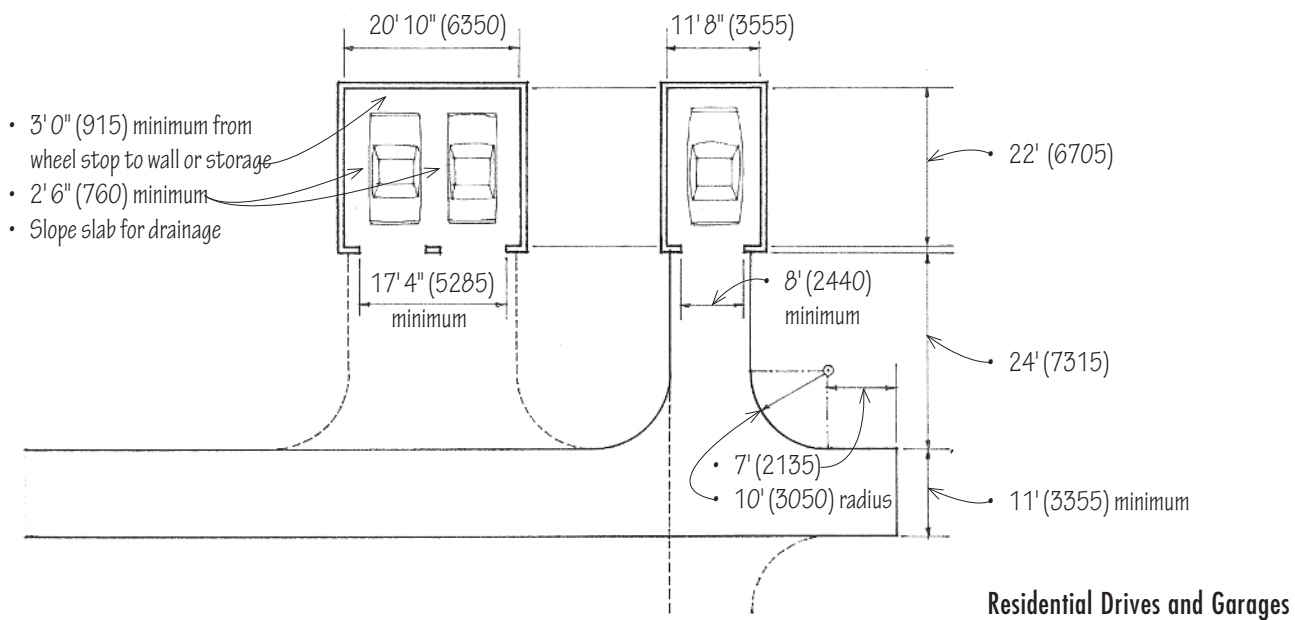
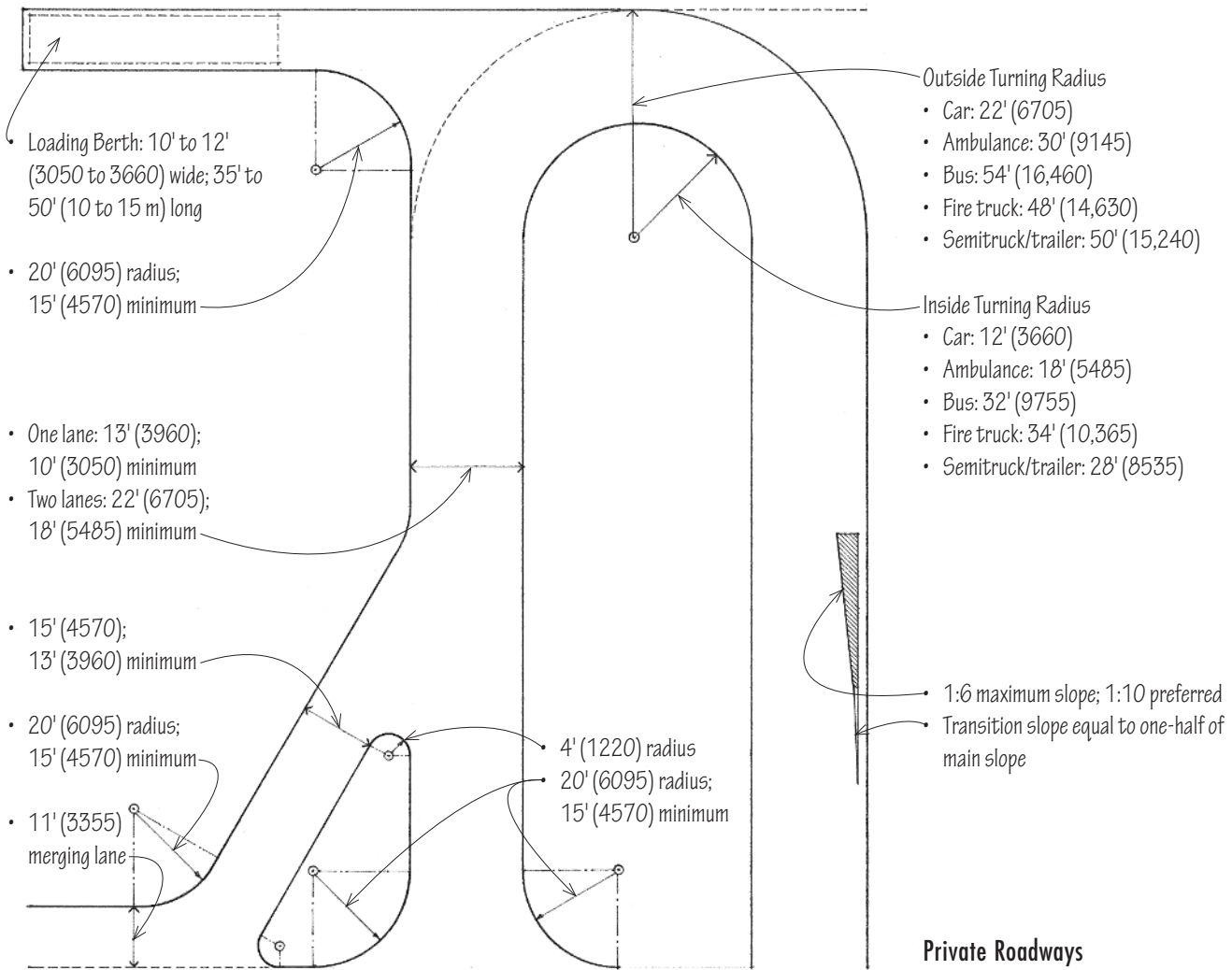

Vehicle Dimensions

- Compact car: 5' 8" x 16' 0" (1725 x 4875)
- Standard car: 6' 6" x 18' 0" (1980 x 5485)

Parking Spaces

- Standard cars: 8' 6" to 9' 0" (2590 to 2745) x 18' 0" to 20' 0" (5485 to 6095)
- Compact cars: 8' 0" (2440) x 16' 0" (4875)

- Slope 1% to 5% for drainage; 2% to 3% recommended.



- Where provided, electric vehicle charging stations are to be installed in accordance with NFPA 70 and are to be listed and labeled in accordance with UL 2202 and UL 2594.

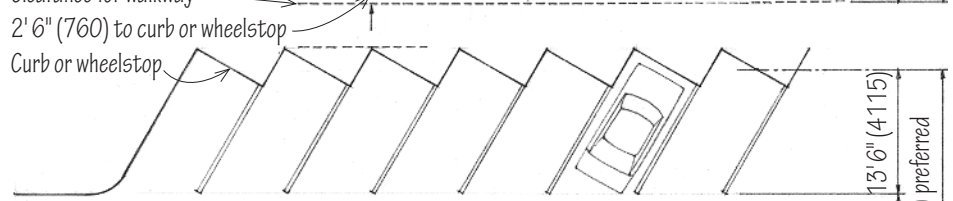
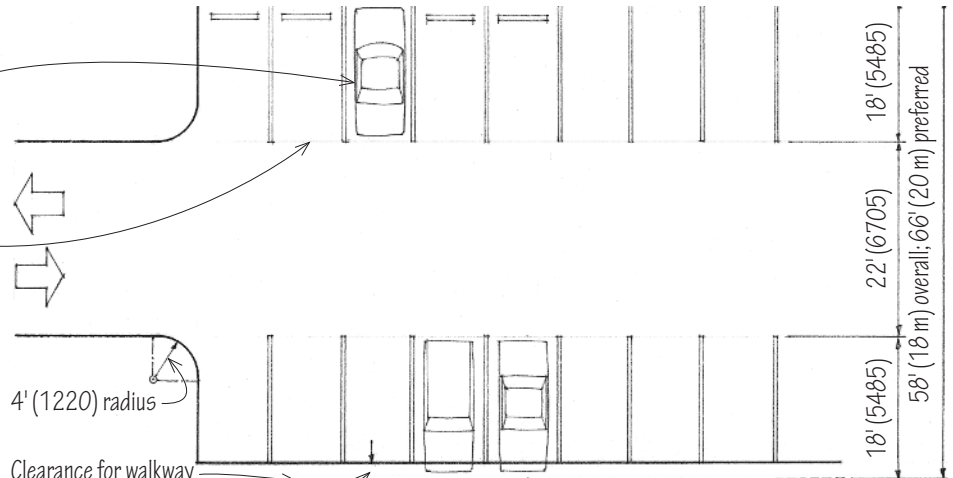

Parking Lots

- 7' (2135) minimum overhead clearance

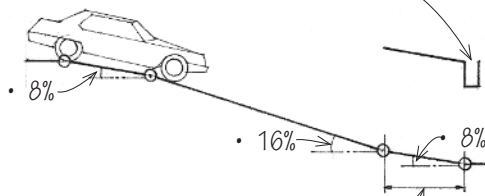

- Transition slope equal to one-half of ramp slope; 10' (3050) length.

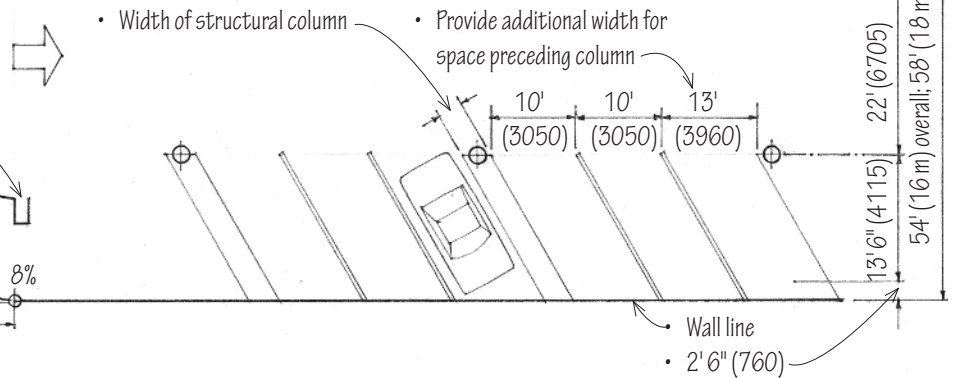

Garage Ramps



- Local, state, and federal laws regulate the number of accessible spaces required.
- Locate accessible parking on the shortest accessible route of travel to the nearest accessible building entrance.
- 1:50 maximum slope for spaces and access aisles.

- 8' (2440) minimum width
- 5' (1525) minimum access aisle; may be shared by two accessible parking spaces.
- Identify accessible parking spaces with a sign showing the international symbol of accessibility.

- At least one van-accessible parking space should be provided for every 6 accessible parking spaces required.
- Van-accessible parking spaces should have a minimum width of 11' (3350), an access aisle at least 5' (1525) wide, and a clear height of 8' 2" (2490).

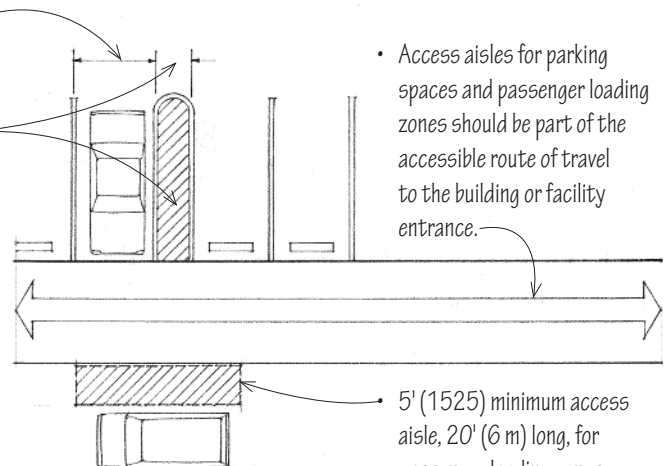

- Access aisles for parking spaces and passenger loading zones should be part of the accessible route of travel to the building or facility entrance.

- 5' (1525) minimum access aisle, 20' (6 m) long, for passenger loading zones adjacent and parallel to the vehicle pull-up space.

ADA Accessibility Guidelines

1.36 SLOPE PROTECTION

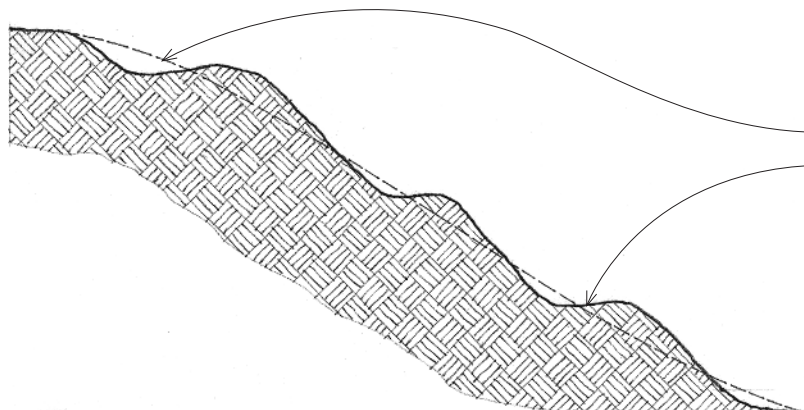

Slopes that are subject to erosion from the runoff of surface water require some means of stabilization. The need for stabilization can be reduced by:

- diverting the runoff at the top of the slope, or by
- creating a series of terraces to reduce the velocity of the runoff.

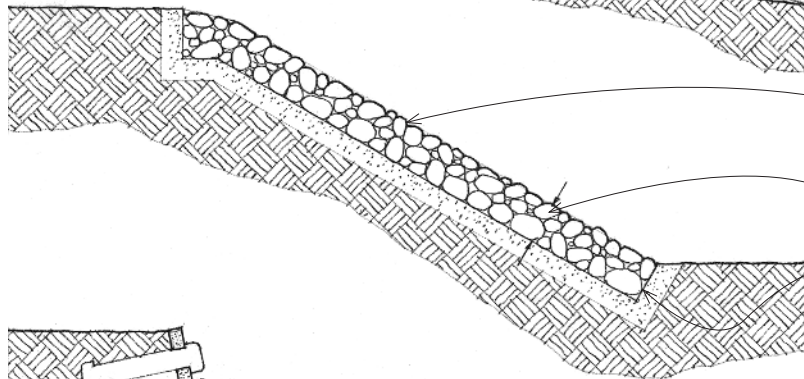

The principal mechanical means of protecting an embankment against erosion is a revetment of riprap or gabions.

- Riprap is a layer of irregularly broken and random-sized stones placed on the slope of an embankment to prevent erosion.
- Depth of layer should be greater than the maximum size of stone.
- Filter fabric or graded sand and gravel for drainage.

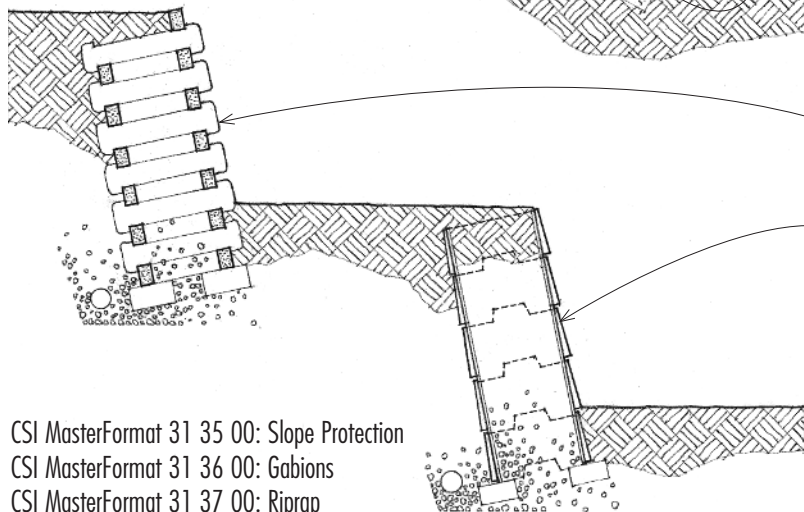

Cribbing or bin walls may also be used to hold back and protect steep embankments.

- Cribbing is a cellular framework of squared steel, concrete, or timber members, assembled in layers at right angles, and filled with earth or stones.
- A bin wall is a type of gravity retaining wall formed by stacking modular, interlocking precast concrete units and filling the voids with crushed stone or gravel.

CSI MasterFormat 31 35 00: Slope Protection
CSI MasterFormat 31 36 00: Gabions
CSI MasterFormat 31 37 00: Riprap

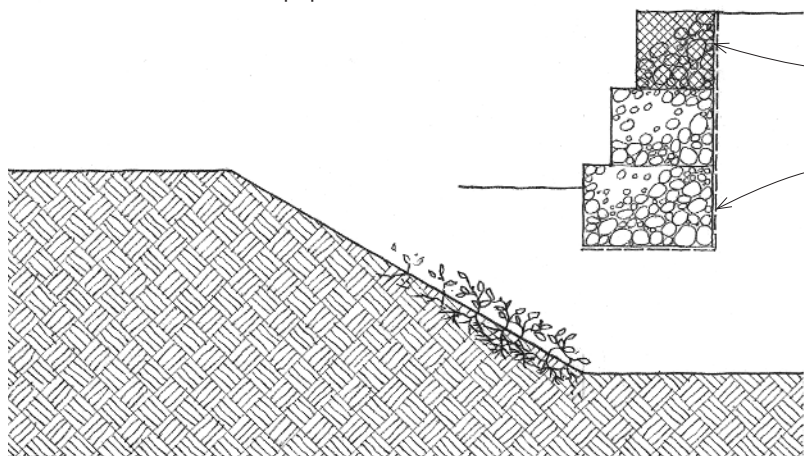

- Gabions are galvanized or PVC-coated wire baskets filled with stones and stacked to form an abutment or retaining structure, or as riprap to stabilize an embankment.
- Filter fabric or graded sand and gravel for drainage.

Natural means of stabilization include soil binders—plant materials that inhibit or prevent erosion by providing a ground cover and forming a dense network of roots that bind the soil.

When a desired change in ground elevation exceeds the angle of repose of the soil, a retaining wall becomes necessary to hold back the mass of earth on the uphill side of the grade change.

A retaining wall must be designed and constructed to resist the lateral pressure of the soil being retained. This active pressure increases proportionally from zero at the upper grade level to a maximum value at the lowest depth of the wall. The total pressure or thrust may be assumed to be acting through the centroid of the triangular distribution pattern, one-third above the base of the wall.

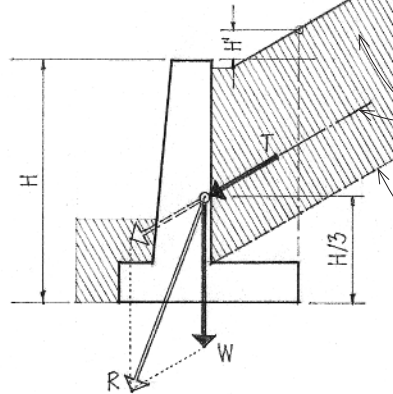
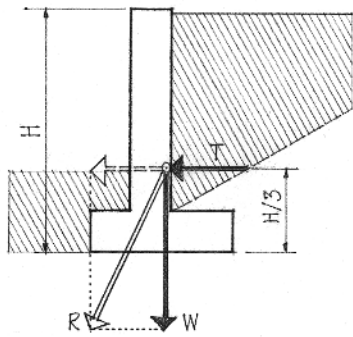
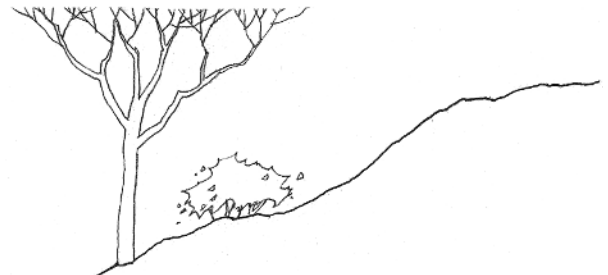

Surcharge is an additional load, as that of the earth above a retaining wall. The line of thrust parallels the slope of the surcharge.

Assume 33° for the angle of repose of most soils. See 1.15 for the angle of repose for bare soil embankments.

- $T = 0.286 \times SH^2/2$

- $T = 0.833 \times S(H + H')^2/2$
(for a retaining wall with surcharge)

A retaining wall may fail by overturning, horizontal sliding, or excessive settling.

- T = total pressure or thrust

- S = weight of retained soil; 100 pcf (1600 kg/m³) typical
- W = composite weight of wall acting through centroid of the section
- R = resultant of T and W

- Thrust tends to overturn wall about toe of base.
- To prevent a retaining wall from overturning, the resisting moment (M_r) of the composite weight of the wall and any soil bearing on the heel of the base ($W \times d$) must counter the overturning moment (M_o) created by the soil pressure ($T \times H/3$). Using a safety factor of 2, $M_r \geq 2M_o$.

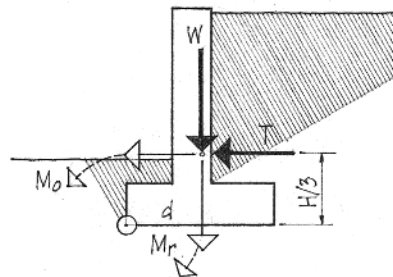

- To prevent a retaining wall from sliding, the composite weight of the wall times the coefficient of friction for the soil supporting the wall ($W \times C.F.$) must counter the lateral thrust on the wall (T). Using a safety factor of 1.5, $W \times C.F. \geq 1.5T$.

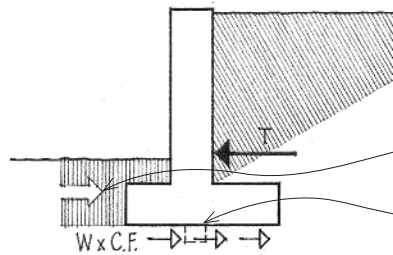

- The passive pressure of the soil abutting the lower level of the wall aids in resisting the lateral thrust (T).
- A key also increases the resistance of the wall to sliding.
- Average coefficients of friction: gravel, 0.6; silt/dry clay, 0.5; sand, 0.4; wet clay, 0.3.

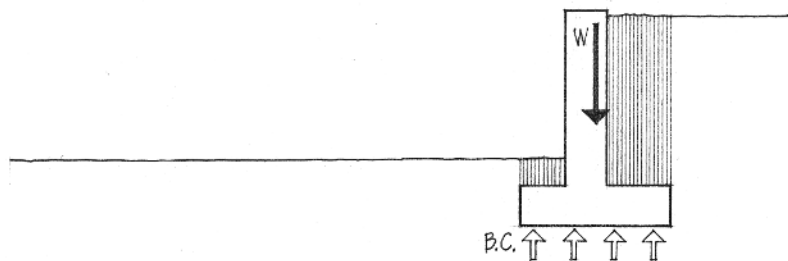

- To prevent a retaining wall from settling, the vertical force (W) must not exceed the bearing capacity of the soil (B.C.), where W = weight of the wall and any soil bearing on the base plus the vertical component of the soil thrust for a wall with surcharge. Using a safety factor of 1.5, $B.C. \geq 1.5W/A$.

1.38 RETAINING WALLS

Reinforced Concrete Retaining Walls

The proportioning guidelines below are for preliminary design only. Consult a structural engineer for final design, especially when a retaining wall is to be built on poor soil or is subject to surcharge or live loads.

Gravity Wall

A gravity retaining wall resists overturning and sliding by the sheer weight and volume of its mass. Gravity walls may be used for retaining structures less than 10' (3048) high.

T-Type Cantilevered Wall

Cantilevered walls of reinforced concrete are used for retaining walls up to 20' (6095) high. Above this height, counterfort walls are employed.

Counterfort Wall

A counterfort wall utilizes triangular-shaped cross walls to stiffen the vertical slab and add weight to the base. The counterforts are spaced at regular intervals equal to one-half the wall height.

L-Type Cantilevered Wall

This type of retaining wall is used when the wall abuts a property line or other obstruction.

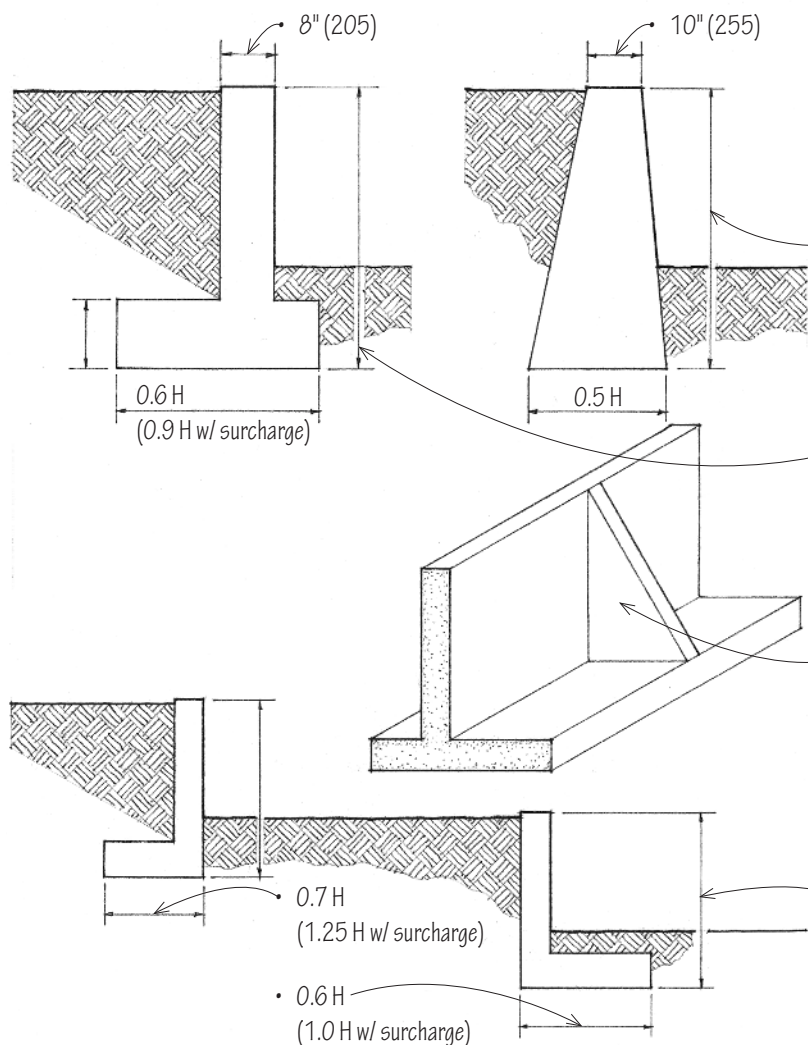

- Batter refers to the backward sloping face of a wall as it rises, which can offset the illusion of the face leaning forward.
- Temperature steel for walls more than 10" (255) thick
- Structural steel reinforcement

- Drainage system may be required to relieve the buildup of water pressure behind the wall.
- Drainage mat w/ filter fabric or porous gravel backfill
- 2" (51) \varnothing weep holes @ 4' to 6' (1220 to 1830) o.c., or perforated drain pipe sloped to outlet away from wall
- 2" (51) minimum
- 3" (75) minimum

- Footing should extend below the frostline or 2' (610) below the lower grade level, whichever is greater.

- Provide vertical control joints @ 25' (7620) o.c., and vertical expansion joints every fourth control joint.

Timber and concrete, brick, or stone masonry may be used for relatively low retaining walls.

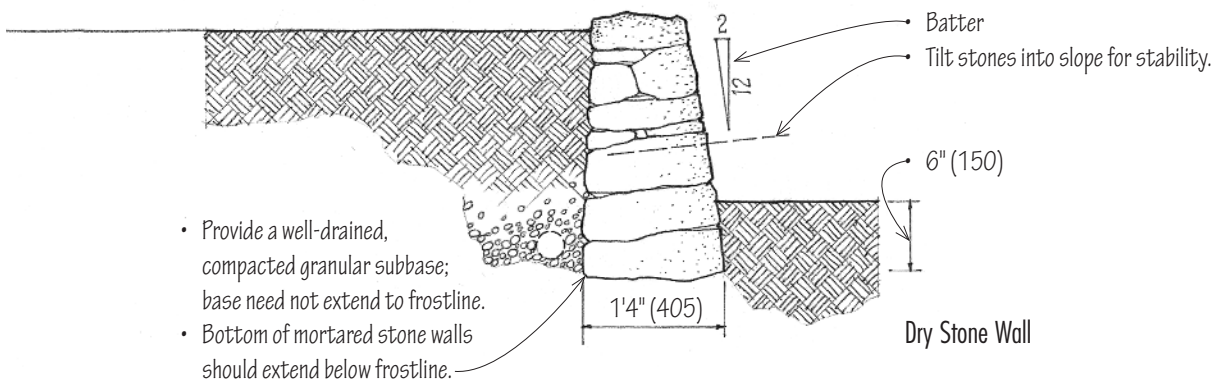
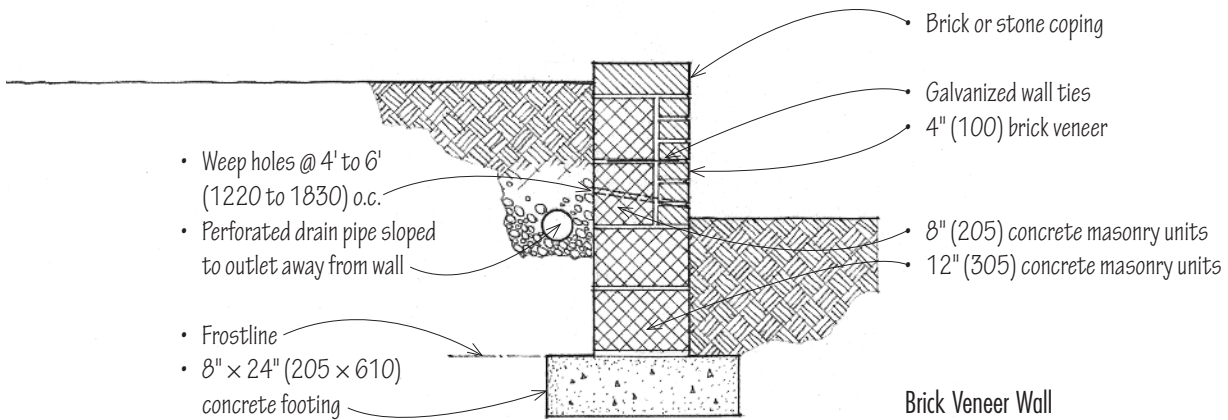
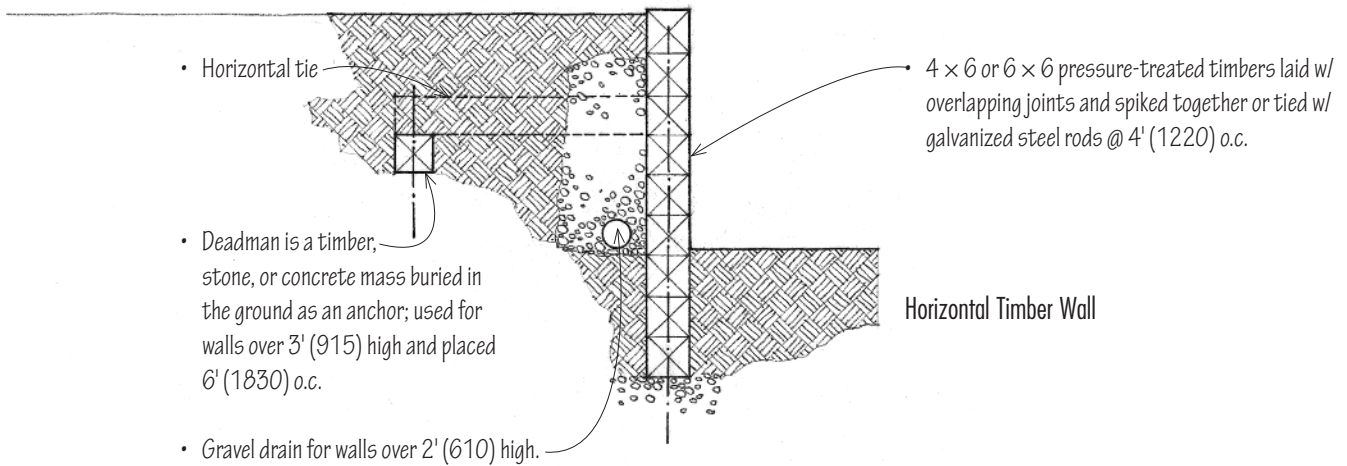

1.40 PAVING

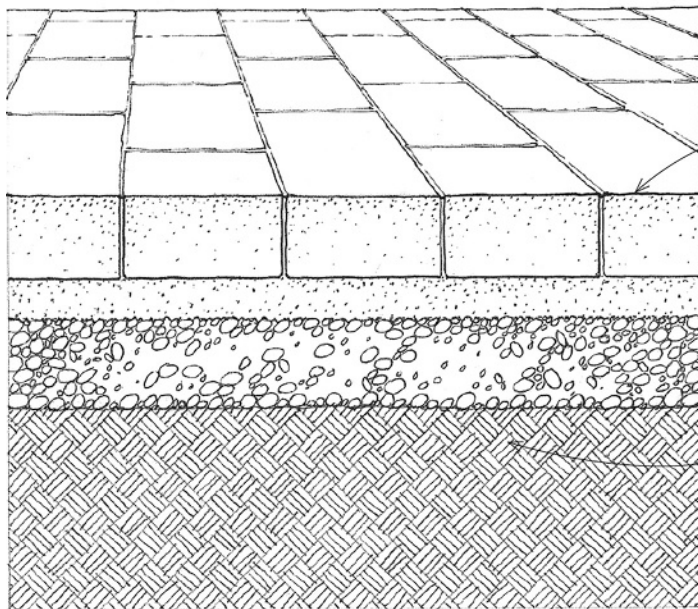

Paving provides a wearing surface for pedestrian or vehicular traffic on a site. It is a composite structure whose thickness and construction are directly related to the type and intensity of traffic and loads to be carried, and the bearing capacity and permeability of the subgrade.

- The pavement receives the traffic wear, protects the base, and transfers its load to the base structure. There are two types of pavement: flexible and rigid.
- The base is a foundation of well-graded aggregate that transfers the pavement load to the subgrade. It also prevents the upward migration of capillary water. Heavy-duty loads may require an additional layer—a subbase of coarser aggregate such as crushed stone.
- The subgrade, which must ultimately carry the pavement load, should be undisturbed soil or compacted fill. Because it may receive moisture from infiltration, it should be sloped to drain.

Flexible pavements, consisting of concrete, brick, or stone unit pavers laid on a sand setting bed, are somewhat resilient and distribute loads to the subgrade in a radiating manner. They require wood, steel, stone, masonry, or concrete edging to restrain the horizontal movement of the paving material. Specially designed unit pavers may qualify as permeable or pervious paving that allows rainfall and stormwater to percolate to an underlying reservoir base where the runoff is either infiltrated to underlying soils or removed by a subsurface drain.

Rigid pavements, such as reinforced concrete slabs or paving units mortared over a concrete slab, distribute their loads internally and transfer them to the subgrade over a broad area. They require reinforcement and an extension of the base material along their edges.

CSI MasterFormat 32 10 00: Bases, Ballasts, and Paving

(LEED SS Credit 4: Rainwater Management) ←

-
- 1% minimum slope for drainage; highly textured paving may require a steeper slope.

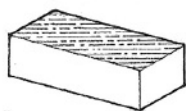

- Brick paver: 4" × 4", 8", 12"; 1"–2" thick (100 × 100, 205, 305; 25–57 thick)

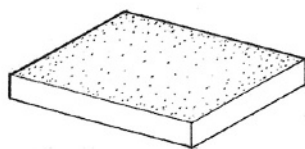

- Concrete unit paver: 12", 18", 24" square; 1½"–3" thick (305, 455, 610 square; 38–75 thick)

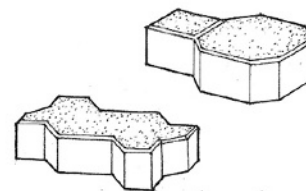

- Interlocking pavers: 2½"–3½" (64–90) thick

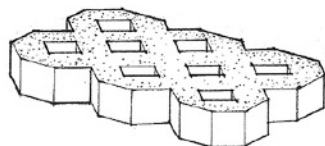

- Grid or turf block: 3½" (90) thick

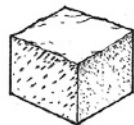

- Granite cobble: 4" or 6" square; 6" thick (100 or 150 square; 150 thick)

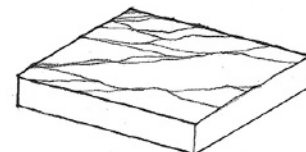

- Cut stone: width and length varies; 1"–2" (25–51) thick

Paving Materials

- Consult local suppliers for availability of shapes, sizes, colors, textures, absorption properties, compressive strength, and installation recommendations.

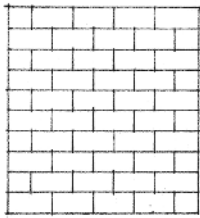

• Unit running bond

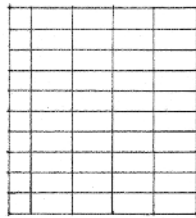

• Stack bond

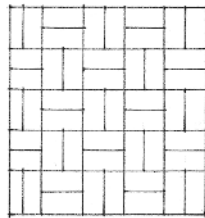

• Unit basketweave

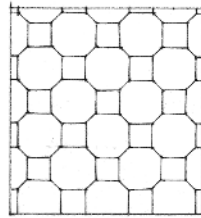

• Interlocking basketweave

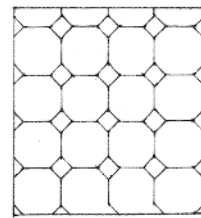

• Octagon and dot

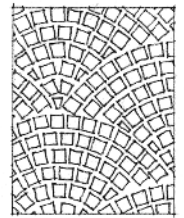

• Roman cobble

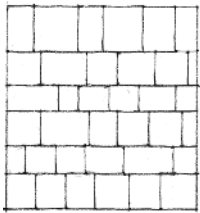

• Coursed ashlar

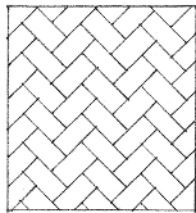

• Unit herringbone

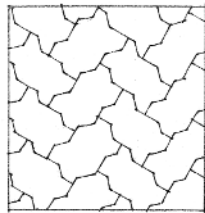

• Interlocking herringbone

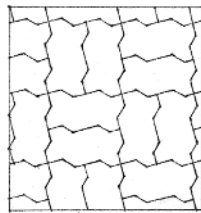

• Interlocking basketweave

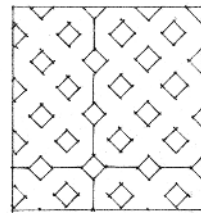

• Turf block

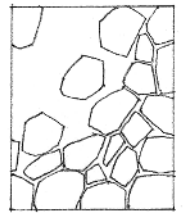

• Random stone

Paving Patterns

- Paving unit on mortar bed, set on edge or laid flat.
- Concrete footing; provide gravel under footing if frost depth is deeper than footing.

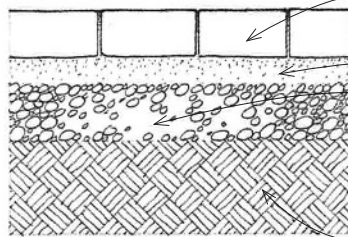
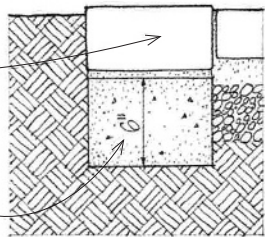

Flexible Base

- Paving unit set vertically on mortar bed; unit may extend up to 1/2 of paver height to form curb.
- Concrete footing

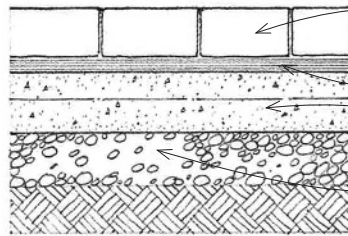
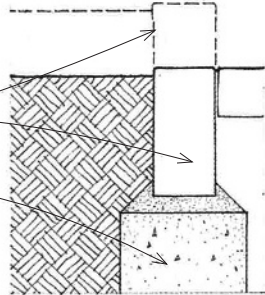

Rigid Base

- 2x, 4x, or 6x pressure-treated wood edge or curb.
- 2" (51) layer of wood chips, crushed stone, or pea gravel.
- 2" (51) base of soil-cement mixture or crushed stone.
- 2 x 2 or 2 x 4 pressure-treated wood stakes, 24" (610) long, @ 3' to 4' (915 to 1220) o.c.

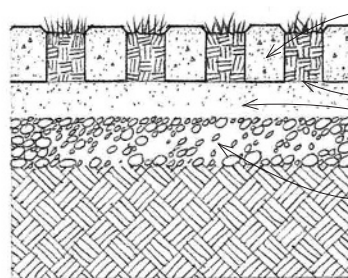
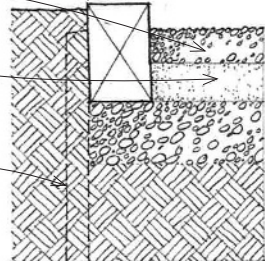

- Unit pavers w/ handtight sand-swept joints.
- 1"-2" (25-51) sand setting bed.
- 2"-6" (51-150) compacted aggregate where required in high traffic areas or over expansive soil.
- Compacted subgrade or undisturbed soil.

- Brick or concrete pavers
- 3/4" (19) bituminous setting bed
- 4"-6" (100-150) concrete slab
- Compacted aggregate, if required

- Turf block
- Topsoil mix for grass or ground cover
- 2" (51) sand setting bed
- 2"-6" (51-150) compacted aggregate

Edge Conditions

1.42 THE SITE PLAN

The site plan illustrates the existing natural and built features of a site and describes proposed construction in relation to these existing features. Usually based on an engineer's land survey, the site plan is an essential piece of a set of construction documents. A completed site plan should include the following items:

1. Name and address of property owner.
2. Address of property, if different from owner's address.
3. Legal description of property.
4. Source and date of land survey.
5. Description of the site boundaries: dimensions of property lines, their bearing relative to north, angles of corners, and radii of curves.
6. Contract or project limits, if different from site boundaries.
7. North arrow and scale of drawing.
8. Location and description of benchmarks that establish the reference points for the location and elevations of new construction.
9. Identification and dimensions of adjacent streets, alleys, and other public rights-of-way.
10. Location and dimensions of any easements or rights-of-way that cross the site.
11. Dimensions of setbacks required by the zoning ordinance.
12. Location and size of existing structures and a description of any demolition required by the new construction.
13. Location, shape, and size of structures proposed for construction, including roof overhangs and other projections.
14. Location and dimensions of existing and proposed paved walkways, drives, and parking areas.
15. Location of existing utilities: water mains, sanitary and storm sewers, gas lines, electrical power lines, telephone and cable lines, and fire hydrants, as well as proposed points of connections.
16. Existing contour lines, new contour lines, and the finish grades of drives, walks, lawns, or other improved surfaces after completion of construction or grading operations.
17. Existing plant materials to remain and those to be removed.
18. Existing water features, such as drainage swales, creeks, flood plains, watersheds, or shorelines.
19. Proposed landscaping features, such as fencing, retaining walls, and plantings; if extensive, landscaping and other site improvements may be shown on a separate site plan.
20. References to related drawings and details.

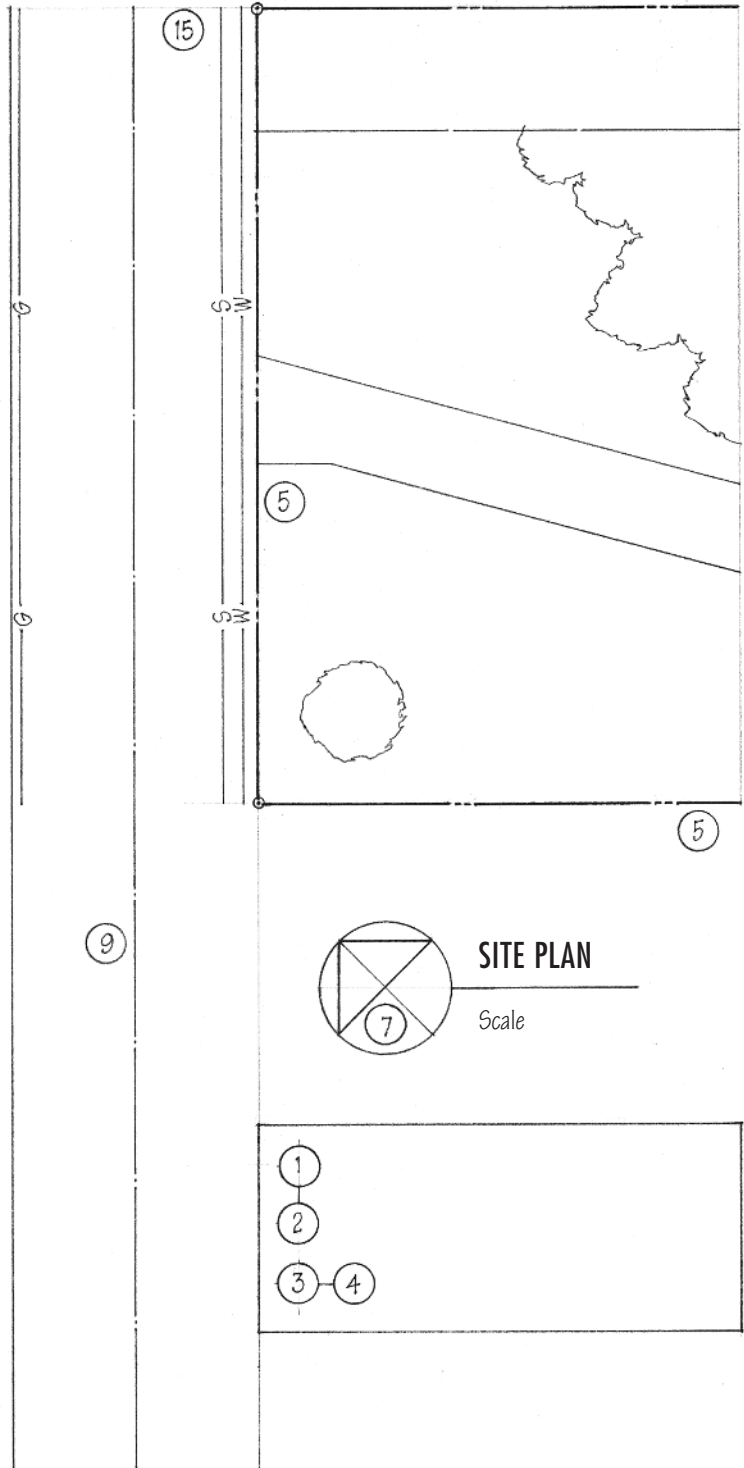

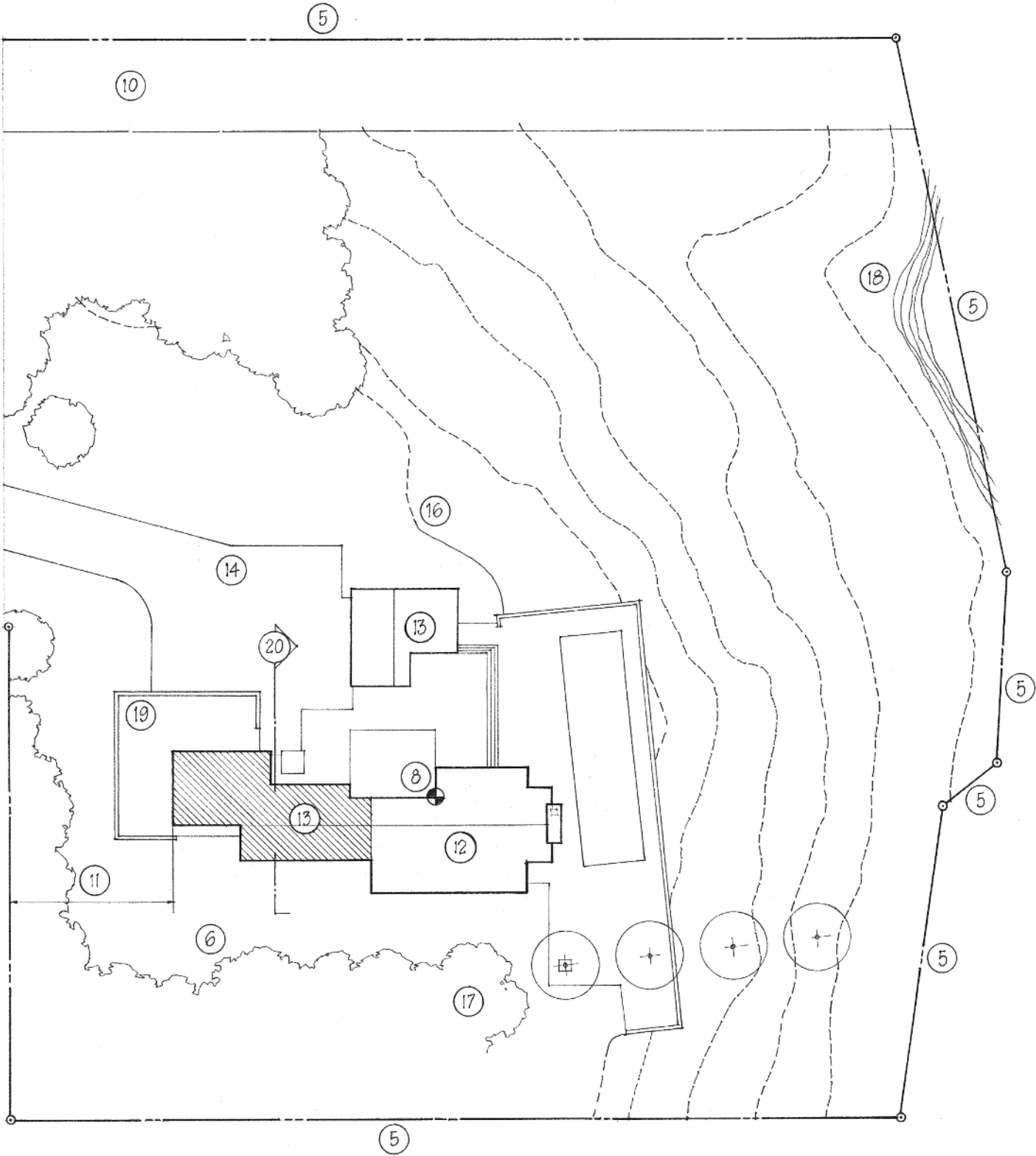

1.44 SITE DESCRIPTION

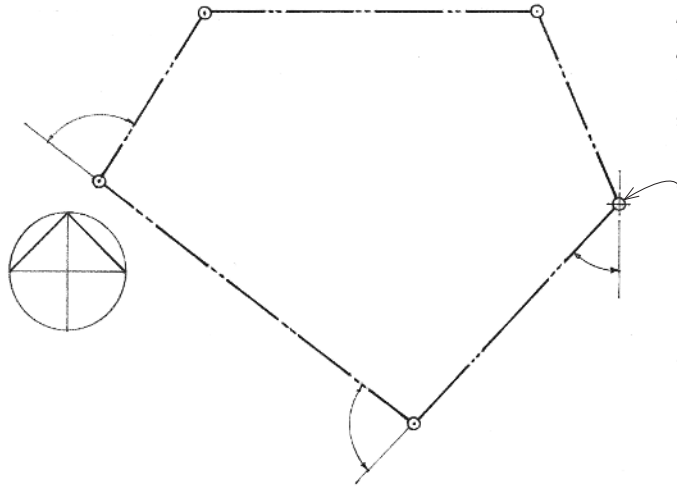

A legal description of a site consists of the location and boundaries of a specific parcel of land, based on a metes-and-bounds survey or a rectangular system of survey, or made with reference to a recorded plat.

A metes-and-bounds survey calls out the course and length of each boundary line of a parcel of land, starting at a known reference point and working around the periphery of the plat until returning to the place of beginning.

- A survey plat is a legal document describing the location, boundaries, and dimensions of a tract or parcel of land, including zoning and planning commission approvals, easements and restrictions, and, for a subdivision, the dividing lines of street, blocks, and lots, and the numbering and dimensions of each lot.

- Principal meridians are north-south reference lines established at substantial landmarks for large areas of land.
- Guide meridians are north-south reference lines located between correction lines at 24-mile (38.62-km) intervals to the east and west of principal meridians.
- Range lines are north-south reference lines located at 6-mile (9.66-km) intervals between guide meridians.
- East-west baseline
- Correction lines are east-west reference lines located at 24-mile (38.62-km) intervals to the north and south of a baseline to correct for the convergence of meridians and equalize east-west distances.

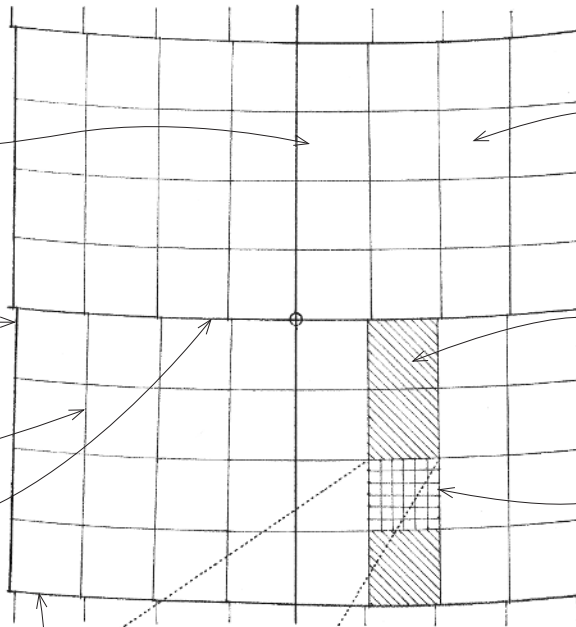

The rectangular system of survey is based on a modified grid of north-south principal and guide meridians and east-west baselines.

Range is one of a series of divisions numbered east or west from a guide meridian and consisting of a row of townships that are numbered north or south from a baseline.

Township is a unit of land area, approximately six miles square (93.2 km²) containing 36 sections.

Section is one of the 36 numbered subdivisions of a township, each approximately one square mile (2.59 km² or 640 acres) and further subdivided into halves, quarters, and quarter-quarters.

