

## 1

## Introduction

Modern society relies heavily on fossil fuel-based transportation for economic and social development – freely moving goods and people. There are about 800 million cars in the world and about 260 million motor vehicles on the road in the United States in 2014 according to the US Department of Transportation's estimate [1]. In 2009, China overtook the United States to become the world's largest automaker and auto market, with output and sales, respectively, hitting 13.79 and 13.64 million units in that year [2]. With further urbanization, industrialization, and globalization, the trend of rapid increase in the number of personal automobiles worldwide is inevitable. The issues related to this trend become evident because transportation relies heavily on oil. Not only are the oil resources on Earth limited, but also the emissions from burning oil products have led to climate change, poor urban air quality, and political conflict. Thus, global energy system and environmental problems have emerged, which can be attributed to a large extent to personal transportation.

Personal transportation offers people the freedom to go wherever and whenever they want. However, this freedom of choice creates a conflict, leading to growing concerns about the environment and concerns about the sustainability of human use of natural resources.

First, the world faces a serious challenge in energy demand and supply. The world consumes approximately 85 million barrels of oil every day, but there are only 1300 billion barrels of proven reserves of oil. At the current rate of consumption, the world will run out of oil in 40 years [3]. New discoveries of oil reserves are at a slower pace than the increase in demand. Of the oil consumed, 60% is used for transportation [4]. The United States consumes approximately 25% of the world's total oil [5]. Reducing oil consumption in the personal transportation sector is essential for achieving energy and environmental sustainability.

Second, the world faces a great challenge from global climate change. The emissions from burning fossil fuels increase the carbon dioxide ( $\text{CO}_2$ ) concentration (also referred to as greenhouse gas or GHG emissions) in the Earth's atmosphere. The increase in  $\text{CO}_2$  concentration leads to excessive heat being captured on the Earth's surface, which leads to a global temperature increase and extreme weather conditions in many parts of the world. The long-term consequences of global warming can lead to rising sea levels and instability of ecosystems.

Gasoline- and diesel-powered vehicles are among the major contributors to  $\text{CO}_2$  emissions. In addition, there are other emissions from conventional fossil fuel-powered vehicles, including carbon monoxide (CO) and nitrogen oxides (NO and  $\text{NO}_2$ , or  $\text{NO}_x$ ) from burning gasoline, hydrocarbons, or volatile organic compounds (VOCs) from evaporated, unburned fuel, and sulfur oxide and particulate matter (soot) from burning diesel fuel. These emissions cause air pollution and ultimately affect human and animal health.

Third, society needs sustainability, but the current model is far from it. Cutting fossil fuel usage and reducing carbon emissions are part of the collective effort to retain human uses of

natural resources within sustainable limits. Therefore, future personal transportation should provide enhanced freedom, sustainable mobility, and sustainable economic growth and prosperity for society. In order to achieve these, vehicles driven by electricity from clean, secure, and smart energy are essential.

Electrically driven vehicles have many advantages and challenges. Electricity is more efficient than the combustion process in a car. Well-to-wheel studies show that, even if the electricity is generated from petroleum, the equivalent distance that can be driven by 1 gallons (3.81) of gasoline is 108 miles (173 km) in an electric car, compared to 33 miles (53 km) in an internal combustion engine (ICE) car [6–8]. In a simpler comparison, it costs 2 cents per mile to use electricity (at US\$0.12 per kWh) but 10 cents per mile to use gasoline (at US\$3.30 per gallon) for a compact car.

Electricity can be generated through renewable sources, such as hydroelectric, wind, solar, and biomass. On the other hand, the current electricity grid has excess capacity available at night when the usage of electricity is off-peak. It is ideal to charge electric vehicles (EVs) at night when the grid has the excess energy capacity.

High cost, limited driving range, and long charging time are the main challenges for battery-powered EVs. Hybrid electric vehicles (HEVs), which use both an ICE and an electric motor to drive the vehicle, overcome the cost and range issues of a pure EV without the need to plug in to charge. The fuel consumption of HEVs can be significantly reduced compared to conventional gasoline engine powered vehicles. However, these vehicles still operate on gasoline/diesel fuel.

Plug-in hybrid electric vehicles (PHEVs) are equipped with a larger battery pack and a larger-sized motor compared to HEVs. PHEVs can be charged from the grid and driven a limited distance (20–40 miles) using electricity, referred to as charge-depletion (CD) mode operation. Once the battery energy has been depleted, PHEVs operate similar to a regular HEV, referred to as charge-sustain (CS) mode operation, or extended range operation. Since most of the personal vehicles are for commuting and 75% of them are driven only 40 miles or less daily [9], a significant amount of fossil fuel can be displaced by deploying PHEVs capable of a range of 40 miles of purely electricity-based propulsion. In the extended range operation, a PHEV works similar to an HEV by using the onboard electric motor and battery to optimize the engine and vehicle system operation to achieve a higher fuel efficiency. Thanks to the larger battery power and energy capacity, the PHEV can recover more kinetic energy during braking, thereby further increasing fuel efficiency.

## 1.1 Sustainable Transportation

The current model of the personal transportation system is not sustainable in the long run because the Earth has limited reserves of fossil fuel, which provide 97% of all transportation energy needs at the present time [10]. To understand how sustainable transportation can be achieved, let us look at the ways energy can be derived and the ways vehicles are powered.

The energy available to us can be divided into three categories: renewable energy, fossil fuel-based non-renewable energy, and nuclear energy. Renewable energy includes hydropower, solar, wind, ocean, geothermal, biomass, and so on. Non-renewable energy includes coal, oil, and natural gas. Nuclear energy, though abundant, is not renewable since there are limited resources of uranium and other radioactive elements on Earth. In addition, there are concerns about nuclear safety (such as the accident in Japan caused by earthquake and tsunami) and nuclear waste processing in the long term. Biomass energy is renewable because it can

**Figure 1.1** A sustainable transportation system.

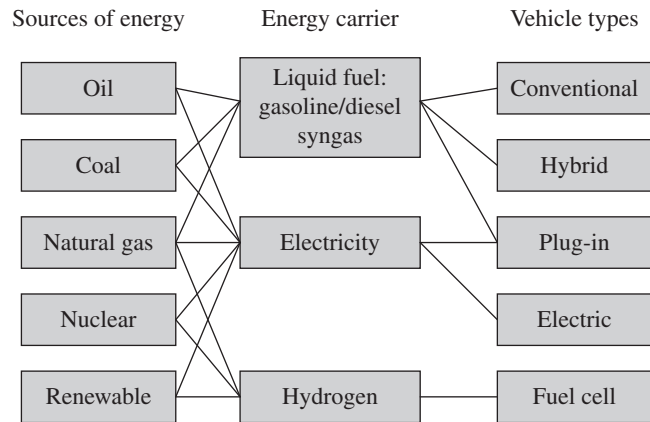

be derived from wood, crops, cellulose, garbage, and landfill. Electricity and hydrogen are secondary forms of energy. They can be generated by using a variety of sources of original energy, including renewable and non-renewable energy. Gasoline, diesel, and syngas are energy carriers derived from fossil fuel.

Figure 1.1 shows the different types of sources of energy, energy carriers, and vehicles. Conventional gasoline-/diesel-powered vehicles rely on liquid fuel, which can only be derived from fossil fuel. HEVs, though more efficient and consuming less fuel than conventional vehicles, still rely on fossil fuel as the primary energy. Therefore, both conventional cars and HEVs are not sustainable. EVs and fuel cell vehicles (FCVs) rely on electricity and hydrogen, respectively. Both electricity and hydrogen can be generated from renewable energy sources; therefore, they are sustainable as long as only renewable energy sources are used for the purpose. PHEVs, though not totally sustainable, offer the advantages of both conventional vehicles and EVs at the same time. PHEVs can displace fossil fuel usage by using grid electricity. They are not the ultimate solution for sustainability, but they build a pathway to future sustainability.

### 1.1.1 Population, Energy, and Transportation

The world's population is growing at a rapid pace, as shown in Figure 1.2a [11]. At the same time, personal vehicle sales are also growing at a rapid pace, as shown in Figure 1.2b ([www.dot.gov](http://www.dot.gov), also [http://en.wikipedia.org/wiki/Passenger\\_vehicles\\_in\\_the\\_United\\_States](http://en.wikipedia.org/wiki/Passenger_vehicles_in_the_United_States)). There is a clear correlation between population growth and the number of vehicles sold every year.

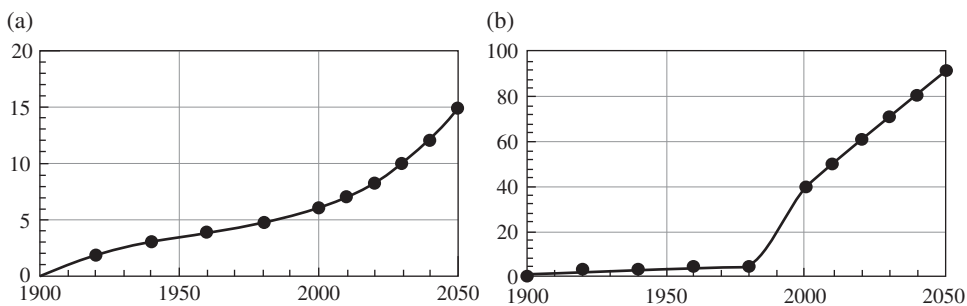

**Figure 1.2** Trends of world population and vehicles sold per year. (a) World population, in billion. (b) Passenger cars sold per year, in millions.

Fuel economy, as used in the United States, evaluates how many miles can be driven with 1 gallon of gas, or miles per gallon (MPG). Fuel consumption, as used in most countries in the world, evaluates the gasoline (or diesel) consumption in liters for every 100 km the car is driven (l per 100 km). The US Corporate Average Fuel Economy Standard, known as the CAFE standard, sets the fuel economy for passenger cars at 27.5 MPG from 1989 to 2008 [12]. With an average fuel economy of 27.5 MPG, an average mileage of 15,000 miles driven per year, and 250 million cars on the road, the United States would consume 136 billion gallons of gasoline per year. This is equivalent to 7 billion barrels of oil, or 0.5% of all the proven oil reserves on Earth.

China surpassed the United States in 2009 to become the largest vehicle market in the world, with more than 13 million motor vehicles sold in 2009. Growth in China has been in double digits for five consecutive years. In 2009, overall vehicle sales dropped by 20% worldwide due to the global financial crisis, but China's car market still grew by more than 6%, along with its sustained economic growth of close to 10%. In 2016, China sold more than 27 million vehicles. China used to be self-sufficient in oil supplies, but is now estimated to import 74% of its oil consumption according to CGEP (Center on Global Energy Policy at Columbia University in the USA: [https://www.energypolicy.columbia.edu/publications/chinas-oil-demand-imports-and-supply-security/#:~:text=In%202024%2C%20China%20imported%2011.1,the%20country's%20apparent%20oil%20consumption.&text=China's%20five%20largest%20crude%20oil,Oman%20\(See%20Figure%202\).](https://www.energypolicy.columbia.edu/publications/chinas-oil-demand-imports-and-supply-security/#:~:text=In%202024%2C%20China%20imported%2011.1,the%20country's%20apparent%20oil%20consumption.&text=China's%20five%20largest%20crude%20oil,Oman%20(See%20Figure%202).)

In addition to industrialized countries such as Japan and Germany, which have high demand for oil imports, developing countries such as India and Brazil have also seen tremendous growth in car sales recently. These countries face the same challenges regarding oil demand and environmental aspects. Figure 1.3 shows liquid energy consumption and demand per day by country [13].

Figure 1.4 shows the history and projections of oil demand and production (<http://www.eia.doe.gov/steo/contents.html>). Many analysts believe in the theory of peak oil at the present time, which predicts that oil production is at its peak in history and will soon be below oil demand. The gap generated by demand and production can most likely cause another energy crisis in the absence of careful planning.

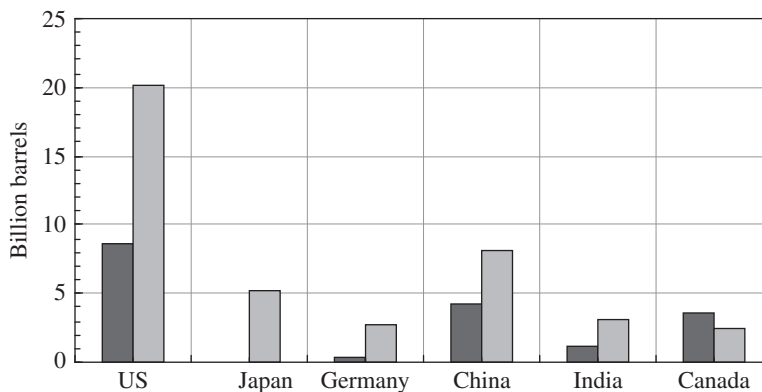

**Figure 1.3** Average crude oil consumption per day by country in 2014, in million barrels. The left column for each country represents the production and the right column the consumption. *Source:* Adapted from [13].

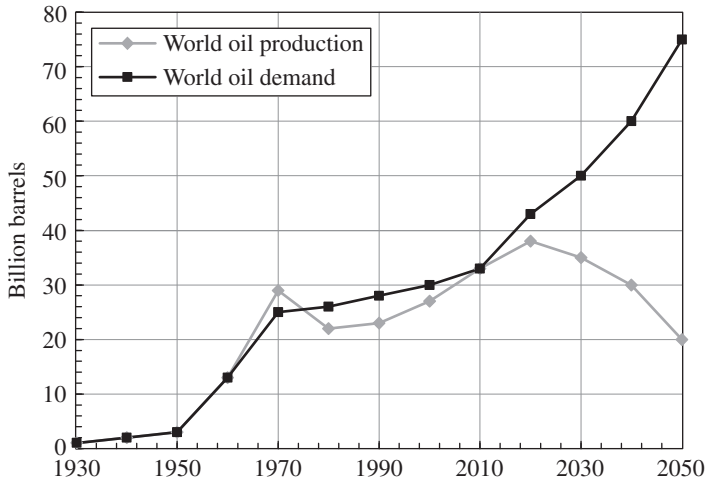
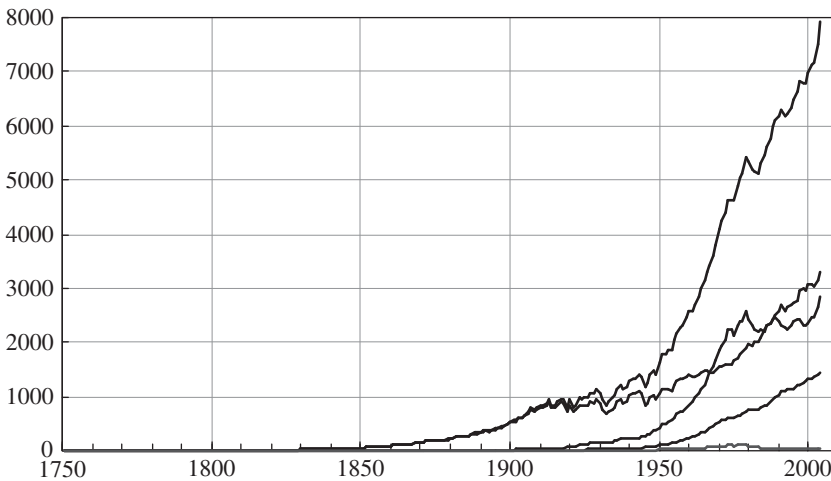

**Figure 1.4** World oil demand and depletion history and projections.

### 1.1.2 Environment

Carbon emissions from burning fossil fuel are the primary source of GHG emissions that lead to global environment and climate change. Figure 1.5 shows the fossil carbon emissions from 1900 to the present [14]. The most dramatic increase in GHG emissions has happened in the past 100 years. Associated with the increase in GHG emissions is the global temperature increase. Figure 1.6 shows the global mean land–ocean temperature change from 1880 to 2015, using the 1951–1980 period as the basis for comparison (<http://data.giss.nasa.gov/gistemp/graphs/>).

As an example of how car emissions contribute to GHG emissions, Figure 1.7 shows the emissions of a typical passenger car during a cold start. Modern cars are equipped with catalytic converters to reduce emissions from the car tailpipes/exhausts. However, the catalytic converter needs to heat up to approximately  $350^{\circ}\text{C}$  in order to function efficiently. It has been



**Figure 1.5** Global fossil carbon emissions from 1800 to 2004 [14]. On the right tip points, from top to bottom: total CO<sub>2</sub>, oil, coal, cement production, and other. Source: ONRL.

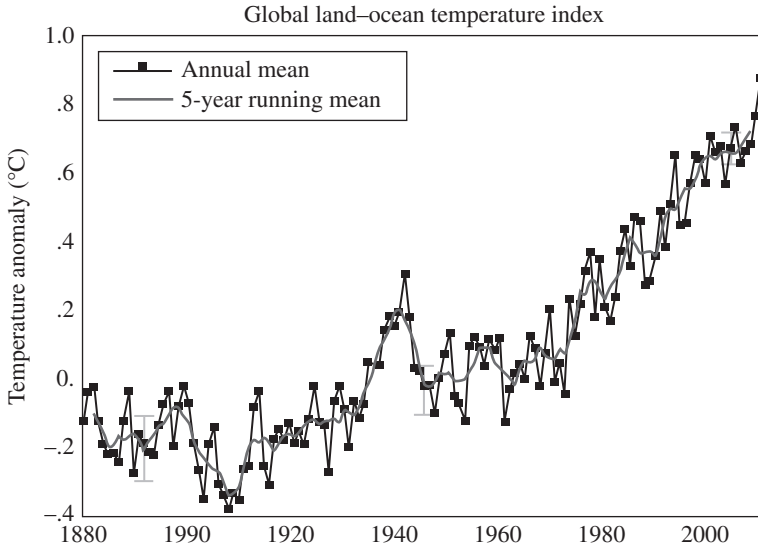

**Figure 1.6** Global annual mean surface air temperature change. *Source:* Data from <http://data.giss.nasa.gov/gistemp/graphs/>. Courtesy NASA.

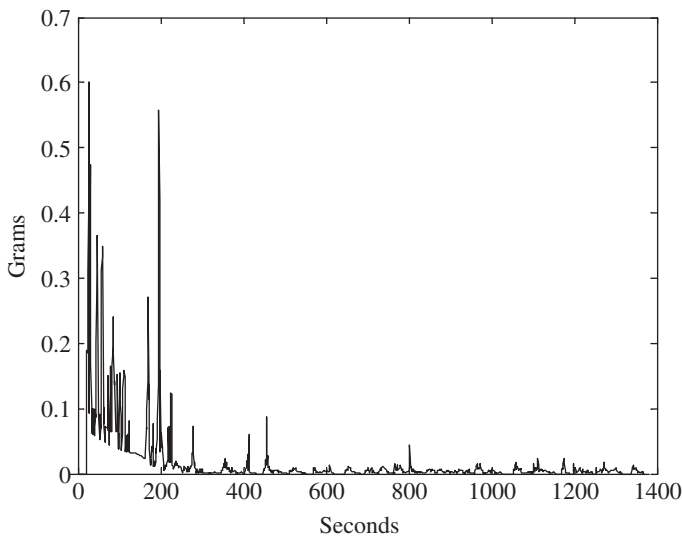
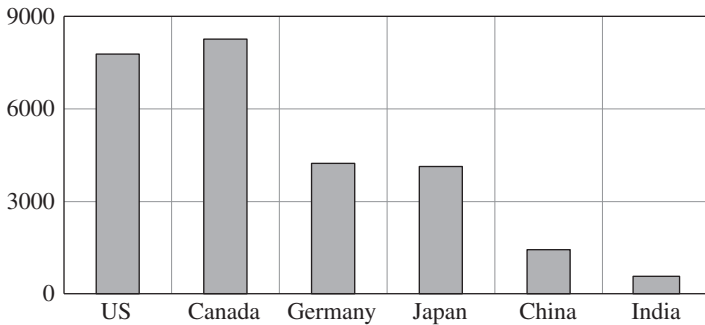

**Figure 1.7** Typical emissions of a passenger car during cold starting (showing the total emissions in grams, made up of hydrocarbons, carbon monoxide, nitrogen oxide, and particulate matter).

estimated that 70–80% of the total emissions occur during the first two minutes after a cold start during a standard driving cycle.

### 1.1.3 Economic Growth

Economic growth relies heavily on energy supply. For example, from 1999 to 2015, China's economy attained an average growth rate of nearly 10%. In the same period, energy demand



**Figure 1.8** Energy consumption per capita in 2014 in kilograms of oil equivalent. *Source:* Adapted from [https://data.worldbank.org/indicator/EG.USE.PCAP.KG.OE?order=wbapi\\_data\\_value\\_2014+wbapi\\_data\\_value+wbapi\\_data\\_value?last&sort=desc](https://data.worldbank.org/indicator/EG.USE.PCAP.KG.OE?order=wbapi_data_value_2014+wbapi_data_value+wbapi_data_value?last&sort=desc).

increased by more than 15% per year. In the early 1990s, China's oil production was sufficient to support its own economy, but as of 2024, China imported about 74% of its liquid fuel consumption as noted earlier.

Figure 1.8 shows the energy consumption per capita, in kilograms of oil equivalent [13]. It is evident that developing countries are still well below the level of the developed countries. To reach sustainability, the global economy must embrace a new model.

#### 1.1.4 New Fuel Economy Requirement

In 2009, the US government announced its new CAFE standard, requiring that all car manufacturers achieve an average fuel economy of 35 MPG by 2020 and 54.5 by 2030. This is equivalent to 6.7l/100 km. The new requirement is a major increase in fuel economy in the United States in 20 years and represents approximately a 40% increase from the current standard as shown in Figure 1.9. This new legislation is a major step forward to effectively reduce energy consumption and GHG emissions. To achieve this goal, a mixed portfolio is necessary for all car manufacturers.

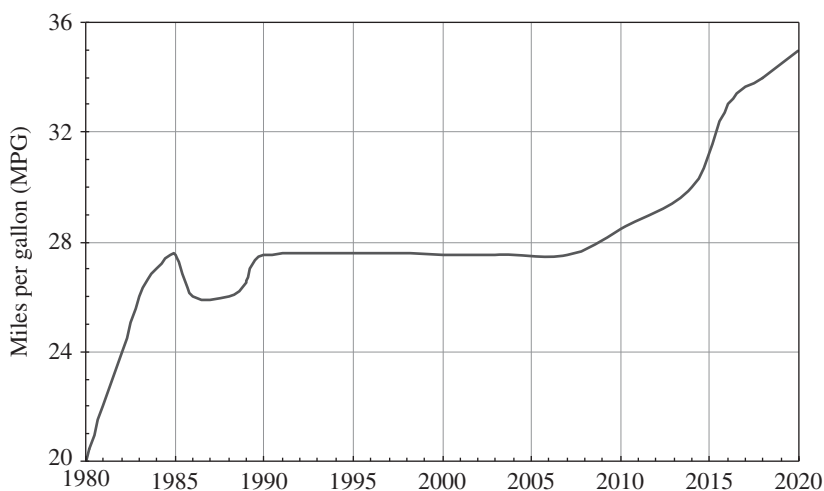

**Figure 1.9** Fuel economy evolution in the United States (CAFE requirements).

First, automakers must shift from large cars and pickup trucks to smaller vehicles to balance the portfolio. Second, they must continue to develop technologies that support fuel efficiency improvements in conventional gasoline engines. Finally and most importantly, they have to increase HEV and PHEV production.

## 1.2 A Brief History of HEVs

EVs were invented in 1834, that is, about 60 years earlier than gasoline-powered cars, which were invented in 1895. By 1900, there were 4200 automobiles sold in the United States, of which 40% were electric cars (<https://science.jrank.org/pages/2320/Electric-Vehicles.html>)

Dr. Ferdinand Porsche in Germany built probably the world's first HEV in 1898, using an ICE to spin a generator that provided power to electric motors located in the wheel hubs (<http://aoghs.org/editors-picks/first-auto-show/>). Another hybrid vehicle, made by the Krieger Company in 1903, used a gasoline engine to supplement the power of the electric motor that used electricity from a battery pack (<http://www.hybridcars.com/history/history-of-hybrid-vehicles.html>). Both hybrids are similar to the modern series HEV.

Also in the 1900s, a Belgian carmaker, Pieper, introduced a 3.5-hp Voiturette in which the small gasoline engine was mated to an electric motor under the seat (<http://en.wikipedia.org/wiki/Voiturette>). When the car was cruising, its electric motor was used as a generator to charge the batteries. When the car was climbing a grade, the electric motor, mounted coaxially with the gas engine, helped the engine to drive the vehicle. In 1905, a US engineer, H. Piper, filed a patent for a petrol–electric hybrid vehicle. His idea was to use an electric motor to assist an ICE, enabling the vehicle to achieve 25 mph. Both hybrid designs are similar to the modern parallel HEV.

In the United States, there were a number of electric car companies in the 1920s, with two of them dominating the EV market – Baker of Cleveland and Woods of Chicago. Both car companies offered hybrid electric cars. However, the hybrid cars were more expensive than gasoline cars and sold poorly.

HEVs, together with EVs, faded away by 1930, and the electric car companies all failed. There were many reasons leading to the disappearance of EVs and HEVs. When compared to gasoline-powered cars, EVs and HEVs:

- were more expensive due to the large battery packs used.
- were less powerful due to the limited power from the onboard battery.
- had a limited range between each charge.
- needed many hours to recharge the onboard battery.

In addition, urban and rural areas lacked accessibility to electricity for charging electric and hybrid cars.

The major progress in gasoline-powered cars also hastened the disappearance of the EVs and HEVs. The invention of starters made the starting of gasoline engines easier, and assembly line production of gasoline-powered vehicles, such as the Model-T by Henry Ford, made these vehicles a lot more affordable than electric and hybrid vehicles.

It was not until the Arab oil embargo of 1973 that the soaring price of gasoline sparked new interest in EVs. The US Congress introduced the Electric and Hybrid Vehicle Research, Development, and Demonstration Act in 1976, recommending the use of EVs as a means of reducing oil dependency and air pollution. In 1990, the California Air Resource Board (CARB), in consideration of the smog affecting Southern California, passed the zero emission vehicle



**Figure 1.10** Ford Electric Ranger.

(ZEV) mandate, which required 2% of vehicles sold in California to have no emissions by 1998 and 10% by 2003. California car sales have approximately a 10% share of the total car sales in the United States. Major car manufacturers were afraid that they might lose the California car market without a ZEV. Hence, every major automaker developed EVs and HEVs. FCVs were also developed in this period. Many EVs, such as GM's EV1, Ford's Ranger pickup EV (Figure 1.10), Honda's EV Plus, Nissan's Altra EV, and Toyota's RAV4 EV, were developed.

In 1993, the US Department of Energy set up the Partnership for Next Generation Vehicle (PNGV) program to stimulate the development of EVs and HEVs. The partnership was a cooperative research program between the US government and major auto corporations, aimed at enhancing vehicle efficiency dramatically. Under this program, the three US car companies demonstrated the feasibility of a variety of new automotive technologies, including an HEV that can achieve 70 MPG. This program was canceled in 2001 and was transitioned to the Freedom CAR (Cooperative Automotive Research), which is responsible for the HEV, PHEV, and battery research programs under the US Department of Energy.

Unfortunately, the EV program faded again away by 2000, with thousands of EV programs terminated by auto companies. This is due partly to the fact that consumer acceptance was not overwhelming and partly to the fact that the CARB relaxed its ZEV mandate.

The world's automotive history turned to a new page in 1997 when the first modern hybrid electric car, the Toyota Prius, was sold in Japan. This car, along with Honda's Insight and Civic HEVs, has been available in the United States since 2000. These early HEVs marked a radical change in the types of cars offered to the public: vehicles that take advantage of the benefits of both battery EVs and conventional gasoline-powered vehicles. At the time of writing, there are more than 40 models of HEVs available in the marketplace from more than 10 major car companies.

### **1.3 Why EVs Emerged and Failed in the 1990s, and What We Can Learn**

During the 1990s, California had a tremendous smog and pollution problem that needed to be addressed. The CARB passed a ZEV mandate that required car manufacturers to sell ZEVs if they wanted to sell cars in California. This led to the development of electric cars by all major

car manufacturers. Within a few years, there were more than 10 production EVs available to consumers, such as the GM EV1, the Toyota RAV4, and the Ford Ranger.

Unfortunately, the EV market collapsed in the late 1990s. What caused the EV industry to fail? The reasons were mixed, depending on how one looks at it, but the following were the main contributors to the collapse of EVs in the 1990s:

- **Limitations of EVs:** These concerned the limited range (most EVs provided 60–100 miles, compared to 300 or more miles from gasoline-powered vehicles); long charging time (eight or more hours); high cost (40% more expensive than gasoline cars); and limited cargo space in many of the EVs.
- **Cheap gasoline:** The operating cost (fuel cost) of cars is insignificant in comparison to the investment that an EV owner makes in buying an EV.
- **Consumers:** Consumers believed that large sports utility vehicles (SUVs) and pickup trucks were safer to drive and more convenient for many other functions, such as towing. Therefore, consumers preferred large SUVs to smaller efficient vehicles (partly due to the low gasoline prices).
- **Car companies:** Automobile manufacturers spent billions of dollars in research, development, and deployment of EVs, but the market did not respond very well. They were losing money in selling EVs at that time. Maintenance and servicing of EVs were additional burdens on the car dealerships. Liability was a major concern, though there was no evidence that EVs were less safe than gasoline vehicles.
- **Gas companies:** EVs were seen as a threat to gas companies and the oil industry. Lobbying by the car and gasoline companies of the federal government and the California government to drop the mandate was one of the key factors, leading to the disappearance of EVs in the 1990s.
- **Government:** The CARB switched at the last minute from a mandate for EVs to hydrogen vehicles.
- **Battery technology:** Lead acid batteries were used in most EVs in the 1990s. The batteries were large and heavy and needed a long time to charge.
- **Infrastructure:** There was limited infrastructure for recharging the EVs.

As we strive for a way toward sustainable transportation, lessons from history will help us avoid the same mistakes. In the current context of HEV and PHEV development, we must overcome many barriers in order to succeed:

- **Key technology:** That is, batteries, power electronics, and electric motors. In particular, without significant breakthroughs in batteries and with gasoline prices continuing at low levels, there will be significant obstacles to the large-scale deployment of EVs and PHEVs.
- **Cost:** HEVs and PHEVs cost significantly more than their gasoline counterparts. Efforts need to be made to cut component and system costs. When savings in fuel can quickly recover the investment in the HEV, consumers will rapidly switch to HEVs and PHEVs.
- **Infrastructure:** This needs to be ready for the large deployment of PHEVs, including electricity generation for increased demand by PHEVs and increased renewable energy generation, and for rapid and convenient charging of grid PHEVs.
- **Policy:** Government policy has a significant impact on the deployment of many new technologies. Favorable policies, including taxation, standards, consumer incentives, investment in research, development, and manufacturing of advanced technology products, will all have a positive impact on the deployment of HEV and PHEV.
- **Approach:** An integrated approach that combines high-efficiency engines, vehicle safety, and smarter roadways will ultimately help form a sustainable future for personal transportation.

## 1.4 Architectures of HEVs

A HEV is a combination of a conventional ICE-powered vehicle and an EV. It uses both an ICE and an electric motor/generator for propulsion. The two power devices, the ICE and the electric motor, can be connected in series or in parallel from the power flow point of view. When the ICE and motor are connected in series, the HEV is a series hybrid in which only the electric motor provides mechanical power to the wheels. When the ICE and the electric motor are connected in parallel, the HEV is a parallel hybrid in which both the electric motor and the ICE can deliver mechanical power to the wheels.

In an HEV, liquid fuel is still the source of energy. The ICE is the main power converter that provides all the energy for the vehicle. The electric motor increases system efficiency, reduces fuel consumption by recovering kinetic energy during regenerative braking, and optimizes the operation of the ICE during normal driving by adjusting the engine torque and speed. The ICE provides the vehicle with an extended driving range, therefore overcoming the disadvantages of a pure EV.

In a PHEV, in addition to the liquid fuel available in the vehicle, there is also electricity stored in the battery, which can be recharged from the electric grid. Therefore, fuel usage can be further reduced.

In a series HEV or PHEV, the ICE drives a generator (referred to as I/G set). The ICE converts energy in the liquid fuel to mechanical energy, and the generator converts the mechanical energy of the engine output to electricity. An electric motor will propel the vehicle using electricity generated by the I/G set. This electric motor is also used to capture the kinetic energy during braking. There will be a battery between the generator and the electric motor to buffer the electric energy between the I/G set and the motor.

In a parallel HEV or PHEV, both the ICE and the electric motor are coupled to the final drive shaft through a mechanical coupling mechanism, such as clutches, gears, belts, or pulleys. This parallel configuration allows both the ICE and the electric motor to drive the vehicle, either in combined mode or separately. The electric motor is also used for regenerative braking and for capturing the excess energy from the ICE during coasting.

HEVs and PHEVs can also have either the series-parallel configuration or a more complex configuration that usually contains more than one electric machine. These configurations can generally further improve the performance and fuel economy of the vehicle with added component cost.

### 1.4.1 Series HEVs

Figure 1.11 shows the configuration of a series HEV. In this HEV, the ICE is the main energy converter that converts the original energy in gasoline to mechanical power. The mechanical output of the ICE is then converted to electricity using a generator. The electric motor moves the final drive using electricity generated by the generator or electricity stored in the battery. The electric motor can receive electricity directly from the engine, from the battery, or both. Since the engine is decoupled from the wheels, the engine speed can be controlled independently of vehicle speed. This not only simplifies the control of the engine, but, more importantly, can also allow the operation of the engine at its optimum speed to achieve the best fuel economy. It also provides flexibility in locating the engine on the vehicle. There is no need for the traditional mechanical transmission in a series HEV. Based on the vehicle operating conditions, the propulsion components on a series HEV can operate with different combinations:

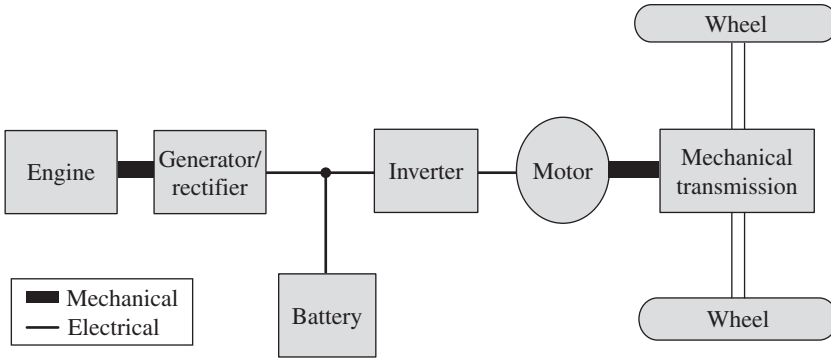

Figure 1.11 The architecture of a series HEV.

- **Battery alone:** When the battery has sufficient energy and the vehicle power demand is low, the I/G set is turned off and the vehicle is powered by the battery only.
- **Combined power:** At high power demands, the I/G set is turned on and the battery also supplies power to the electric motor.
- **Engine alone:** During highway cruising and at moderately high power demands, the I/G set is turned on. The battery is neither charged nor discharged. This is mostly due to the fact that the battery’s state of charge (SOC) is already at a high level, but the power demand of the vehicle prevents the engine from off or it may not be efficient to turn the engine off.
- **Power split:** When the I/G is turned on, the vehicle power demand is below the I/G optimum power, and the battery SOC is low, a portion of the I/G power is used to charge the battery.
- **Stationary charging:** The battery is charged from the I/G power without the vehicle being driven.
- **Regenerative braking:** The electric motor is operated as a generator to convert the vehicle’s kinetic energy into electric energy and charge the battery.

A series HEV can be configured in the same way that conventional vehicles are configured, that is, the electric motor in place of the engine as shown in Figure 1.11. Other choices are also available, such as in-wheel hub motors. In this case, as shown in Figure 1.12, there are four electric motors, one installed inside each wheel. Due to the elimination of the transmission

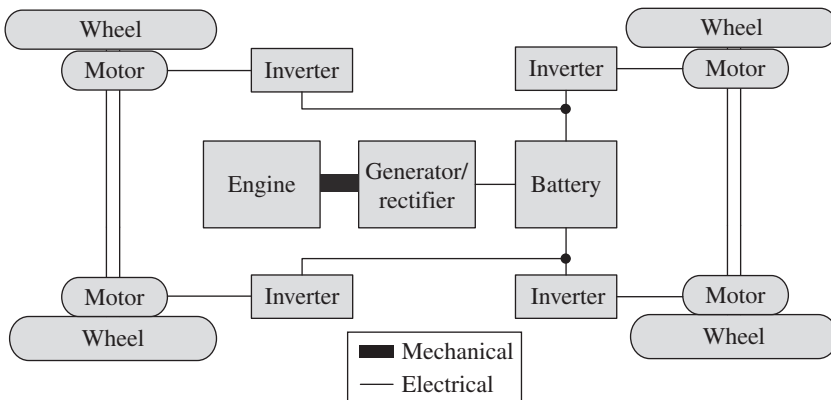

Figure 1.12 Hub motor configuration of a series HEV.

and final drive, the efficiency of the vehicle system can be significantly increased. The vehicle will also have all-wheel drive (AWD) capability. However, controlling the four electric motors independently can be a challenge.

### 1.4.2 Parallel HEVs

Figure 1.13 shows the configuration of a parallel hybrid. In this configuration, the ICE and the electric motor are coupled to the final drive through a mechanism such as clutches, belts, pulleys, and gears. Both the ICE and the motor can deliver power to the final drive, either in combined mode or each separately. The electric motor can be used as a generator to recover the kinetic energy during braking or by absorbing a portion of power from the ICE. The parallel hybrid needs only two propulsion devices, the ICE and the electric motor, which can be used in the following modes:

- **Motor-alone mode:** When the battery has sufficient energy and the vehicle power demand is low, the engine is turned off and the vehicle is powered by the motor and battery only.
- **Combined power mode:** At high power demands, the engine is turned on and the motor also supplies power to the wheels.
- **Engine-alone mode:** During highway cruising and at moderately high power demands, the engine provides all the power needed to drive the vehicle. The motor remains idle. This is mostly due to the fact that the battery SOC is already at a high level but the power demand of the vehicle prevents the engine from turning off, or it may not be efficient to turn the engine off.
- **Power split mode:** When the engine is on, but the vehicle power demand is low and the battery SOC is also low, a portion of the engine power is converted to electricity by the motor to charge the battery.
- **Stationary charging mode:** The battery is charged by running the motor as a generator and driven by the engine, without the vehicle being driven.
- **Regenerative braking mode:** The electric motor is operated as a generator to convert the vehicle's kinetic energy into electric energy and store it in the battery. Note that in regenerative mode it is, in principle, possible to run the engine as well and provide additional current to charge the battery more quickly (while the propulsion motor is in generator mode) and command its torque accordingly, that is, to match the total battery power input. In this case, the engine and motor controllers have to be properly coordinated.

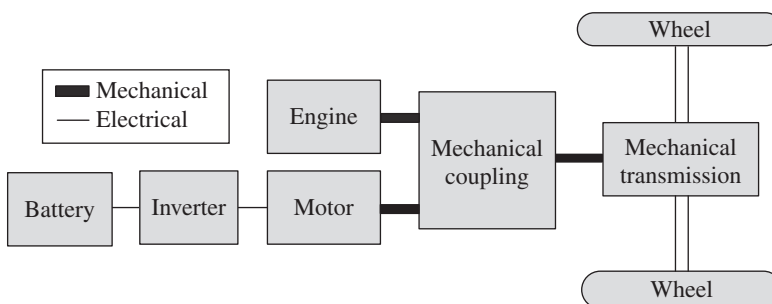

Figure 1.13 The architecture of a parallel HEV.

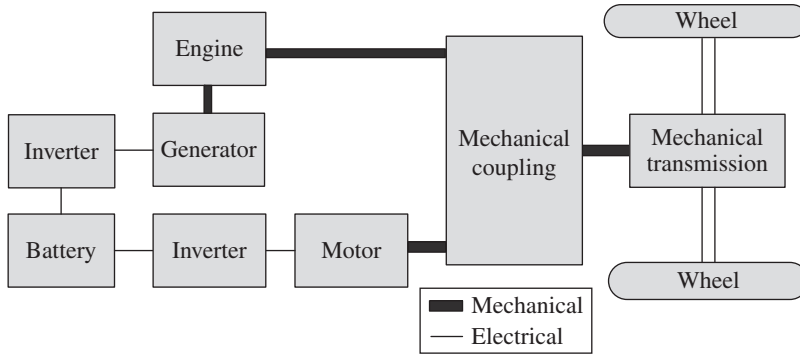

Figure 1.14 The architecture of a series-parallel HEV.

**1.4.3 Series-Parallel HEVs**

The series-parallel HEV shown in Figure 1.14 incorporates the features of both a series and a parallel HEV. Therefore, it can be operated as a series or parallel HEV. In comparison with a series HEV, the series-parallel HEV adds a mechanical link between the engine and the final drive, so the engine can drive the wheels directly. When compared to a parallel HEV, the series-parallel HEV adds a second electric machine that serves primarily as a generator.

Because a series-parallel HEV can operate in both parallel and series modes, the fuel efficiency and drivability can be optimized based on the vehicle’s operating condition. The increased degree of freedom in control makes the series-parallel HEV a popular choice. However, due to increased components and complexity, a series-parallel HEV is generally more expensive than a series or a parallel HEV.

**1.4.4 Complex HEVs**

Complex HEVs usually involve the use of planetary gear systems and multiple electric motors (in the case of four-wheel drive [4WD]/AWD). One typical example is a 4WD system that is realized through the use of separate drive axles, as shown in Figure 1.15. The generator in this system is used to realize the series operation as well as to control the engine operating condition for maximum efficiency. The two electric motors are used to realize AWD and to provide

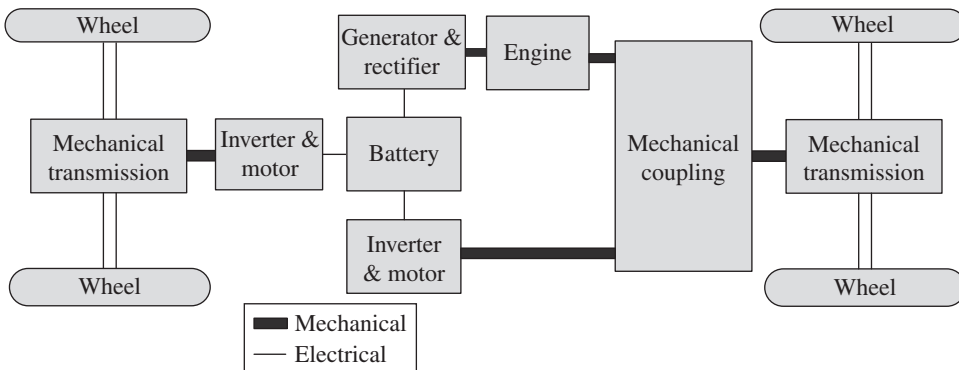

Figure 1.15 The electrical four-wheel drive system using a complex architecture.

better performance in regenerative braking. They may also enhance vehicle stability control and antilock braking control by their use.

### 1.4.5 Diesel and Other Hybrids

HEVs can also be built around diesel vehicles. All topologies explained earlier, such as series, parallel, series–parallel, and complex HEVs, are applicable to diesel hybrids. Due to the fact that diesel vehicles can generally achieve a higher fuel economy, the fuel efficiency of hybridized diesel vehicles can be even better when compared to their gasoline counterparts.

Vehicles such as delivery trucks and buses have unique driving patterns and relatively low fuel economy. When hybridized, these vehicles can provide significant fuel savings. Hybrid trucks and buses can be series, parallel, series–parallel, or complex structured and may run on gasoline or diesel.

Diesel locomotives are a special type of hybrid. A diesel locomotive uses a diesel engine and generator set to generate electricity. It uses electric motors to drive the train. Even though a diesel locomotive can be referred to as a series hybrid, in some architectures there is no battery for the main drive system to buffer energy between the I/G set and the electric motor. This special configuration is sometimes referred to as *simple hybrid*. In other architectures, batteries are used and can help reduce the size of the generator and can also be used for regenerative energy capture. The batteries, in this case, can also be utilized for short-term high current due to torque needs, without resorting to a larger generator.

### 1.4.6 Other Approaches to Vehicle Hybridization

The main focus of this book is on HEVs, that is, electric–gasoline or electric–diesel hybrids. However, there exist other types of hybridization methods that involve other types of energy storage and propulsion, such as compressed air, flywheels, and hydraulic systems. A typical hydraulic hybrid is shown in Figure 1.16. Hydraulic systems can provide a large amount of torque, but due to the complexity of the hydraulic system, a hydraulic hybrid is considered only for large trucks and utility vehicles where frequent and extended period of stops of the engine are necessary.

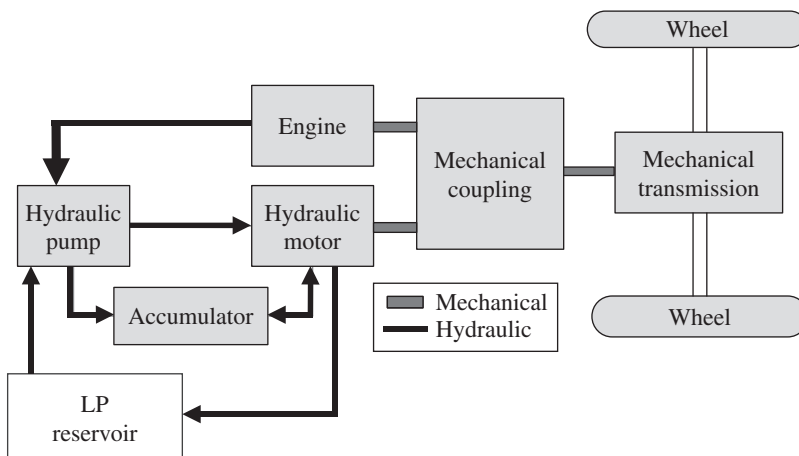

Figure 1.16 A parallel hydraulic hybrid vehicle (LP, low pressure).

### 1.4.7 Hybridization Ratio

Some new concepts have also emerged in the past few years, including full hybrid, mild hybrid, and micro-hybrid. These concepts are usually related to the power rating of the main electric motor in an HEV. For example, if the HEV contains a fairly large electric motor and associated batteries, it can be considered a full hybrid. But if the size of the electric motor is relatively small, then it may be considered a micro-hybrid.

Typically, a full hybrid should be able to operate the vehicle using the electric motor and battery up to a certain speed limit and drive the vehicle for a certain amount of time. The speed threshold is typically the speed limit in a residential area. The typical power rating of an electric motor in a full hybrid passenger car is 50–75 kW.

The micro-hybrid, on the other hand, does not offer the capability to drive the vehicle with the electric motor only. The electric motor is merely for starting and stopping the engine. The typical rating of electric motors used in micro-hybrids is less than 10 kW. A mild hybrid is in between a full hybrid and a micro-hybrid.

An effective approach for evaluating HEVs is to use a hybridization ratio to reflect the degree of hybridization of an HEV. In a parallel hybrid, the hybridization ratio is defined as the ratio of electric power to the total powertrain power. For example, an HEV with a motor rated at 50 kW and an engine rated at 75 kW will have a hybridization ratio of  $50/(50 + 75) \text{ kW} = 40\%$ . A conventional gasoline-powered vehicle has a 0% hybridization ratio, and a battery EV has a hybridization ratio of 100%. A series HEV will also have a hybridization ratio of 100% due to the fact that the vehicle is capable of being driven in EV mode.

## 1.5 Interdisciplinary Nature of HEVs

HEVs involve the use of electric machines, power electronics converters, and batteries, in addition to conventional ICEs and mechanical and hydraulic systems. The interdisciplinary nature of HEV systems can be summarized in Figure 1.17. The HEV field involves engineering

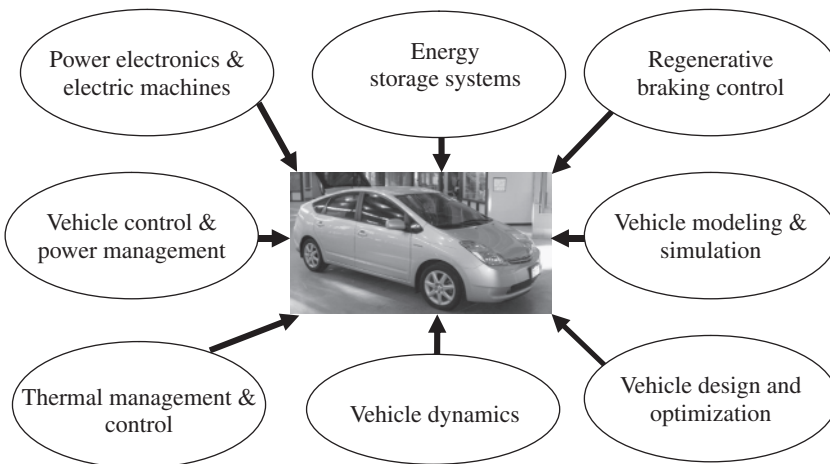

Figure 1.17 The general nature and required engineering field by HEVs.

subjects beyond traditional automotive engineering, which is mechanical engineering oriented. Power electronics, electric machines, energy storage systems, and control systems are now integral parts of the engineering of HEVs and PHEVs.

In addition, thermal management is also important in HEVs and PHEVs because the power electronics, electric machines, and batteries all require a much lower temperature to operate properly, compared to a non-hybrid vehicle's powertrain components. Modeling and simulation, vehicle dynamics, and vehicle design and optimization also pose challenges to the traditional automotive engineering field due to the increased difficulties in packaging the components and associated thermal management systems, as well as the changes in vehicle weight, shape, and weight distribution.

## 1.6 State of the Art of HEVs

In the past 20 years, many HEVs have been deployed by major automotive manufacturers. Figure 1.18 shows HEV, PHEV, and EV sales in the United States from 2000 to 2021 (<https://www.bts.gov/content/gasoline-hybrid-and-electric-vehicle-sales>) and Figure 1.19 shows the US HEV sales by models. Table 1.1 shows HEV sales by model from 1999 to 2019 (<https://afdc.energy.gov/data/10301>) and Table 1.2 shows the partial list of HEVs available in the USA. It is clear that HEV sales have grown significantly over the past 20 years. However, from 2008 onward, occasionally, these sales had a downturn, which is consistent with conventional car sales which dropped by more than 20% in 2008 compared to the previous year. Another observation is that most HEV sales belong to Toyota, which manufactured the earliest modern HEV, the Prius, and also makes most of the models available (including the Lexus).

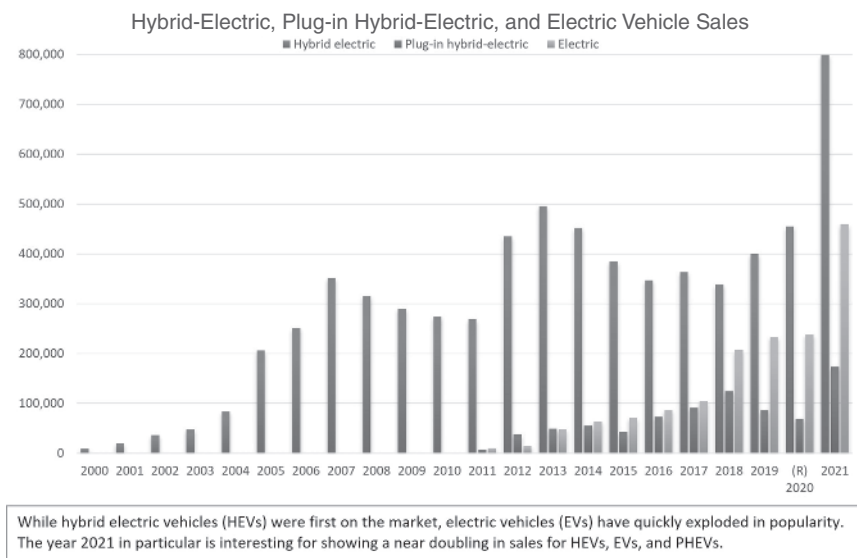

**Figure 1.18** Total numbers of HEVs, PHEVs, and EVs sold in the United States from 2000 to 2021. Source: Adapted from <https://www.bts.gov/content/gasoline-hybrid-and-electric-vehicle-sales>.

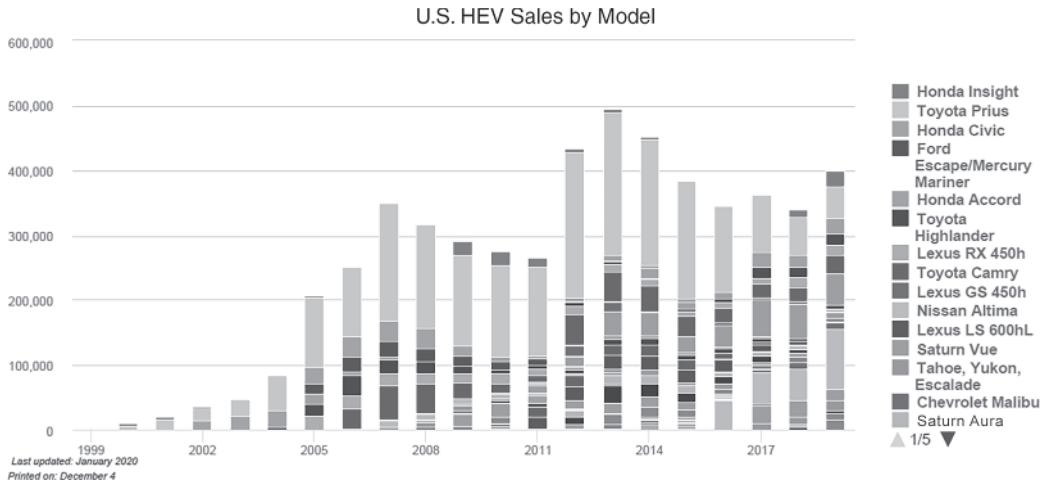

**Figure 1.19** HEV sales by model – label at the right is partial and the full list can be found in <https://afdc.energy.gov/data/10301>. *Source:* Courtesy of U.S. Department of Energy.

### 1.6.1 Toyota Prius

Toyota produced the world's first mass-marketed modern HEV in 1997, the Prius, as shown in Figure 1.20. The worldwide sales of the Prius exceeded 1 million units in 2009. The Toyota Prius uses a planetary gear set to realize continuous variable transmission (CVT). Therefore, the conventional transmission is not needed in this system. As shown in Figure 1.21, the engine is connected to the carrier of the planetary gear, while the generator is connected to the sun gear. The ring gear is coupled to the final drive, as is the electric motor. The planetary gear set also acts as a power/torque splitting device. During normal operations, the ring gear speed is determined by the vehicle speed, while the generator speed can be controlled such that the engine speed is in its optimum efficiency range.

The 6.5 Ah, 2.1 kW nickel metal hydride battery pack is charged by the generator during coasting and by the propulsion motor (in generation mode) during regenerative braking. The engine is shut off during low-speed driving.

The same technology is used in the Camry hybrid, the Highlander hybrid, and the Lexus brand hybrids. However, the Highlander and the Lexus hybrids add a third motor at the rear wheel. The drive performance, such as for acceleration and braking, can thus be further improved.

### 1.6.2 The Honda Civic

The Honda Civic hybrid has an electric motor mounted between the ICE and the CVT, as shown in Figure 1.22. The electric motor either provides assistance to the engine during high power demand, or splits the engine power during low power demand.

### 1.6.3 The Ford Escape

The Escape hybrid from the Ford Motor Company (Figure 1.23) is the first hybrid in the SUV category. The Escape hybrid uses the same planetary gear concept as the Toyota system.

### 1.6.4 The Two-Mode Hybrid

The GM two-mode hybrid transmission was initially developed by GM (Alison) in 1996 and later advanced by GM, Chrysler, BMW, and Mercedes-Benz through a joint venture named

**Table 1.1** HEV sales by model (in order of market introduction).

<b>Vehicle</b>	<b>1999</b>	<b>2000</b>	<b>2001</b>	<b>2002</b>	<b>2003</b>	<b>2004</b>	<b>2005</b>	<b>2006</b>	<b>2007</b>	<b>2008</b>	<b>2009</b>	<b>2010</b>	<b>2011</b>	<b>2012</b>	<b>2013</b>	<b>2014</b>	<b>2015</b>	<b>2016</b>	<b>2017</b>	<b>2018</b>	<b>2019</b>	<b>Total</b>
Honda Insight	17	3788	4726	2216	1168	583	666	722	3	-	20,572	20,962	15,549	5846	4802	3965	1458	75	3	12,510	23,686	123,317
Toyota Prius	-	5562	15,556	20,119	24,627	53,991	107,897	106,971	181,221	158,886	139,682	140,928	136,463	223,906	222,140	194,108	180,603	134,155	87,725	59,995	47,862	2,242,397
Honda Civic	-	-	-	13,707	21,771	26,013	25,864	31,253	32,575	31,297	15,119	7336	4703	7156	7719	5070	4887	896	65	6	-	235,437
Ford Escape/ Mercury Mariner	-	-	-	-	-	2,993	15,960	22,549	25,108	19,522	16,480	12,088	10,089	1441	-	-	-	-	-	-	-	126,230
Honda Accord	-	-	-	-	-	653	16,826	5598	3405	198	1	-	-	-	996	13,977	11,065	9179	22,008	17,188	23,817	124,911
Toyota Highlander	-	-	-	-	-	-	17,989	31,485	22,052	19,391	11,086	7456	4549	5921	5070	3621	4015	5976	16,864	14,513	18,248	188,236
Lexus RX 450h	-	-	-	-	-	-	20,674	20,161	17,291	15,200	14,464	15,119	10,723	12,223	11,307	9,351	7,722	8561	8568	15,656	16,116	203,136
Toyota Camry	-	-	-	-	-	-	-	31,341	54,477	46,272	22,887	14,587	9,241	45,656	44,448	39,515	30,640	22,227	20,985	22,914	26,043	431,233
Lexus GS 450h	-	-	-	-	-	-	-	1784	1645	678	469	305	282	607	522	183	91	70	50	40	7	6733
Nissan Altima	-	-	-	-	-	-	-	-	8,388	8819	9357	6710	3236	103	-	-	-	-	-	-	-	36,613
Lexus LS 600hL	-	-	-	-	-	-	-	-	937	980	258	129	85	54	115	65	47	40	-	211	187	3108
Saturn Vue	-	-	-	-	-	-	-	-	3969	3399	2656	50	-	-	-	-	-	-	-	-	-	10,074
Tahoe, Yukon, Escalade	-	-	-	-	-	-	-	-	-	7612	7192	3857	1877	1801	1036	137	25	-	-	-	-	23,537
Chevrolet Malibu	-	-	-	-	-	-	-	-	-	3118	4162	405	24	16,664	13,779	1018	59	4335	4452	2447	1237	51,700
Saturn Aura	-	-	-	-	-	-	-	-	-	310	527	55	-	-	-	-	-	-	-	-	-	892
Aspen & Durango	-	-	-	-	-	-	-	-	-	81	42	-	-	-	-	-	-	-	-	-	-	123
Silverado & Sierra	-	-	-	-	-	-	-	-	-	-	1598	2393	1165	940	169	30	3	-	1	-	-	6299

(Continued)

**Table 1.1 (Continued)**

Vehicle	1999	2000	2001	2002	2003	2004	2005	2006	2007	2008	2009	2010	2011	2012	2013	2014	2015	2016	2017	2018	2019	Total
Ford Fusion & Milan	-	-	-	-	-	-	-	-	-	-	17,022	22,232	11,286	14,100	37,270	35,425	24,681	33,648	57,474	54,157	49,603	356,898
Lexus HS 250h	-	-	-	-	-	-	-	-	-	-	6699	10,663	2864	650	5	-	-	-	-	-	-	20,881
Mercedes S400	-	-	-	-	-	-	-	-	-	-	-	955	309	121	64	10	1	-	-	-	-	1460
Mercedes ML450	-	-	-	-	-	-	-	-	-	-	-	766	1	22	11	20	10	-	-	-	-	830
Mercedes E320	-	-	-	-	-	-	-	-	-	-	-	-	59	-	-	-	-	-	-	-	-	59
Mazda Tribute	-	-	-	-	-	-	-	-	-	-	-	655	484	90	-	-	-	-	-	-	-	1229
BMW X6 & Activehybrid 3&5&7	-	-	-	-	-	-	-	-	-	-	-	350	381	1040	1456	308	63	64	-	-	-	3662
Honda CR-z	-	-	-	-	-	-	-	-	-	-	-	5249	11,330	4192	4550	3562	3073	2338	705	38	2	35,039
Lincoln MKZ	-	-	-	-	-	-	-	-	-	-	-	1192	5739	6067	7469	10,033	8403	7219	5931	4407	5147	61,607
Porsche Cayenne	-	-	-	-	-	-	-	-	-	-	-	206	1571	1180	615	650	-	-	-	-	-	4222
Lexus CT 200h	-	-	-	-	-	-	-	-	-	-	-	-	14,381	17,671	15,071	17,673	14,657	8903	4690	4	-	93,050
VW Touareg	-	-	-	-	-	-	-	-	-	-	-	-	390	250	118	30	16	1	-	-	-	805
Infinity Q70 (formerly M Hybrid)	-	-	-	-	-	-	-	-	-	-	-	-	378	691	475	180	176	118	58	22	-	2098
Hyundai Sonata	-	-	-	-	-	-	-	-	-	-	-	-	17,366	20,754	21,559	21,052	19,908	18,961	10,338	4526	2636	137,100
Buick LaCrosse	-	-	-	-	-	-	-	-	-	-	-	-	1801	12,010	7133	7353	4042	765	506	2809	1057	37,476
Buick Regal	-	-	-	-	-	-	-	-	-	-	-	-	123	2564	2893	662	186	45	6	-	-	6479
Porsche Panamera S	-	-	-	-	-	-	-	-	-	-	-	-	52	570	113	-	-	-	-	-	-	735

Kia Optima	-	-	-	-	-	-	-	-	-	10,245	13,919	13,776	11,492	6,142	5,589	5,924	10,54	68,141
Acura ILX	-	-	-	-	-	972	1,461	379	1	-	-	-	22	1	-	-	-	2835
Ford C-Max Hybrid	-	-	-	-	-	10,935	28,056	19,162	14,177	-	-	-	11,877	10,221	6,101	38	-	100,567
Lexus ES Hybrid	-	-	-	-	-	7027	16,562	14,837	11,241	-	-	-	7,645	5,394	5,250	8,608	-	76,564
Audi Q5 Hybrid	-	-	-	-	-	270	854	283	97	18	-	-	-	-	-	-	-	1522
Toyota Avalon	-	-	-	-	-	747	16,468	17,048	11,956	8,451	4,990	8,008	-	-	-	6,552	-	74,220
VW Jetta	-	-	-	-	-	162	5,655	19,39	740	709	70	1	-	-	-	-	-	9276
Mercedes E400h	-	-	-	-	-	-	282	158	53	14	3	-	-	-	-	-	-	510
Infiniti Q50	-	-	-	-	-	-	307	3,456	4,012	1,998	870	300	300	870	300	129	-	11,072
Chevrolet Impala Hybrid	-	-	-	-	-	-	56	565	272	35	1	-	-	-	-	-	-	929
Infiniti QX60	-	-	-	-	-	-	676	1678	2,356	1,114	298	-	-	-	-	-	-	6122
Nissan Pathfinder Hybrid	-	-	-	-	-	-	334	2,480	2,245	816	389	-	-	-	-	-	-	6264
Subaru XV	-	-	-	-	-	-	-	7,926	5,589	2,173	45	-	-	-	-	572	-	16,305
Acura RLX	-	-	-	-	-	-	-	133	250	199	292	690	451	2015	451	-	-	2015
Lexus NX Hybrid	-	-	-	-	-	-	-	354	2,573	2,842	3,323	9062	9649	27,803	9649	-	-	27,803
Toyota RAV4	-	-	-	-	-	-	-	-	1,494	45,070	50,559	48,122	92,525	237,770	92,525	-	-	237,770
Acura NSX	-	-	-	-	-	-	-	-	-	269	581	170	238	1258	238	-	-	1258
Kia Niro	-	-	-	-	-	-	-	-	-	-	27,237	25,743	18,336	71,316	18,336	-	-	71,316
Hyundai Ioniq Hybrid	-	-	-	-	-	-	-	-	-	-	10,770	13,068	15,558	39,396	15,558	-	-	39,396

(Continued)

**Table 1.1** (Continued)

Vehicle	1999	2000	2001	2002	2003	2004	2005	2006	2007	2008	2009	2010	2011	2012	2013	2014	2015	2016	2017	2018	2019	Total
Acura MDX Hybrid	-	-	-	-	-	-	-	-	-	-	-	-	-	-	-	-	-	-	1807	2106	2130	6043
GMC Sierra Hybrid	-	-	-	-	-	-	-	-	-	-	-	-	-	-	-	-	-	-	-	3643	114	3757
Lexus LC500h	-	-	-	-	-	-	-	-	-	-	-	-	-	-	-	-	-	-	-	102	37	139
Nissan Rogue Hybrid	-	-	-	-	-	-	-	-	-	-	-	-	-	-	-	-	-	-	-	3363	4205	7568
Lexus LS 500h	-	-	-	-	-	-	-	-	-	-	-	-	-	-	-	-	-	-	-	123	-	123
Lexus UX	-	-	-	-	-	-	-	-	-	-	-	-	-	-	-	-	-	-	-	-	8603	8603
Toyota Corolla	-	-	-	-	-	-	-	-	-	-	-	-	-	-	-	-	-	-	-	-	16,299	16,299
<b>Total</b>	17	9350	20,282	36,042	47,566	84,233	205,876	251,864	351,071	315,763	290,273	274,648	266,501	434,648	495,535	452,172	384,400	346,949	362,868	343,219	400,746	5,374,023

**Abbreviation:** HEV, Hybrid electric vehicle.

**Note:** Year refers to calendar year, not model year.

**Data Source:** Transportation Research Center at Argonne National Laboratory, [anl.gov/es/light-duty-electric-drive-vehicles-monthly-sales-updates](http://anl.gov/es/light-duty-electric-drive-vehicles-monthly-sales-updates) Worksheet available at [afdc.energy.gov/data](http://afdc.energy.gov/data). Last updated January 2020.

**Table 1.2** Partial list of HEVs available in the United States (data from 2011).

Manufacturer	Model	HEV price (US \$)	Base model price (US \$)	Price increase (%)	HEV MPG		Base MPG		Increase in MPG (%)	
					City	Hwy	City	Hwy	City	Hwy
Toyota	Prius <sup>a)</sup>	22,800	15,450	47.6	51	48	26	35	96	37
	Camry	26,400	19,595	34.7	33	34	22	33	50	3
	Highlander	34,900	25,855	35.0	27	25	20	27	35	12
Ford/Mercury	Fusion	27,950	19,695	41.9	41	36	22	34	86	6
	Escape	29,860	21,020	42.1	34	31	22	28	55	11
	Mariner	30,105	23,560	27.8	34	31	21	28	62	11
	Milan	31,915	21,860	46.0	41	26	23	34	78	-24
Honda	Insight <sup>b)</sup>	19,800	15,655	26.5	40	43	26	34	54	26
	Civic	23,800	15,655	52.0	40	45	26	34	54	32
Nissan	Altima	26,780	19,900	34.6	35	33	23	32	52	3
Lexus	RX 450h	42,685	37,625	13.4	32	28	18	25	78	12
	GS 450h	57,450	54,070	6.3	22	25	17	24	29	4
	LS 600h	108,800	74,450	46.1	20	22	16	23	25	-4
	Tahoe	50,720	37,280	36.1	21	22	15	21	40	5
GM GMC, Chevrolet, and Cadillac Saturn <sup>c)</sup>	Yukon	51,185	38,020	34.6	21	22	15	21	40	5
	Sierra	38,710	20,850	85.7	21	22	15	22	40	0
	Malibu	22,800	21,825	4.5	26	34	22	33	18	3
	Escalade	73,425	62,495	17.5	21	22	13	20	62	10
	Silverado	38,340	29,400	30.4	22	21	13	17	69	24
	Aspen <sup>d)</sup>	44,700	40,000	11.8	18	19	15	20	38	6
Chrysler Dodge	Durango <sup>d)</sup>	45,900	40,365	13.7	18	19	15	20	38	6

a) Compared to Corolla.

b) Compared to Civic.

c) Saturn Brand vehicle, including Vue and Saturn Aura, are not offered.

d) Chrysler Aspen uses similar platform to Durango but is no longer offered.



**Figure 1.20** The Toyota Prius (2023 model). *Source:* Core/Wikimedia Commons/CC BY SA 4.0.

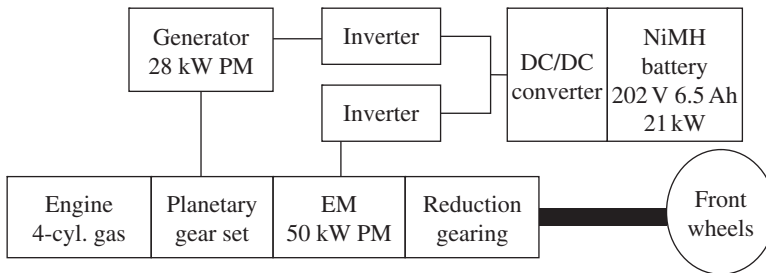

**Figure 1.21** The powertrain layout of the Toyota Prius (EM, electric machine; PM, permanent magnet).

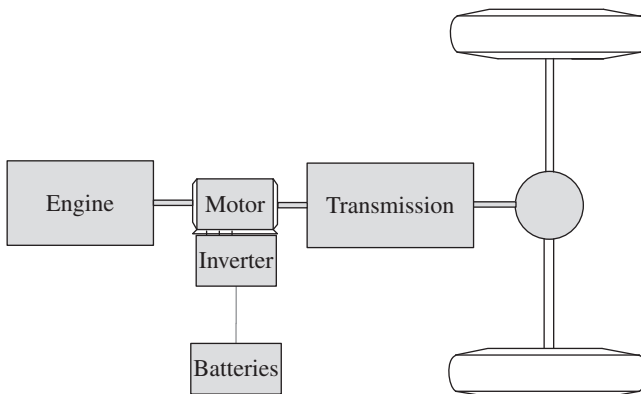

**Figure 1.22** The powertrain layout of the Honda Civic hybrid.

the Global Hybrid Cooperation in 2005. The GM two-mode hybrids (Figure 1.24) use two planetary gear sets and two electric machines to realize two different operating modes, namely, high-speed mode and low-speed mode. Detailed operation of the two-mode hybrid will be discussed in Chapter 4.

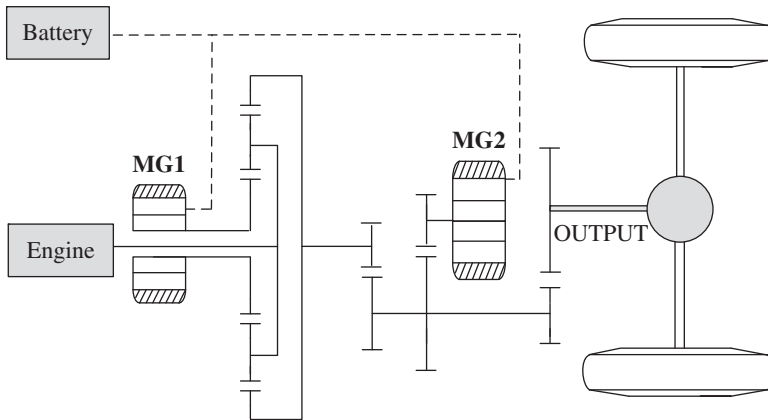

Figure 1.23 The Ford Escape hybrid SUV.



Figure 1.24 The Chrysler Aspen two-mode hybrid.

## 1.7 Challenges and Key Technology of HEVs

HEVs can overcome some of the disadvantages of battery-powered pure EVs and gasoline-powered conventional vehicles. These advantages include optimized fuel economy and reduced emissions when compared to conventional vehicles, and increased range, reduced charging time, and reduced battery size (hence reduced cost) when compared to pure EVs.

However, HEVs and PHEVs still face many challenges, including higher cost when compared to conventional vehicles, electromagnetic interference caused by high-power components, and safety and reliability concerns due to increased components and complexity, packaging of the system, vehicle control, and power management.

- **Power electronics and electric machines:** The subject of power electronics and electric motors is not new. However, the use of power electronics in a vehicle environment poses significant challenges. Environmental conditions, such as extremely high and low temperatures,

vibration, shock, and transient behavior, are very different from what usually affects electric motors and power electronic converters. Challenges in power electronics in an HEV include packaging, size, cost, and thermal management.

- **Electromagnetic interference:** High-frequency switching and high-power operation of power electronics and electric motors will generate abundant electromagnetic noise that will interfere with the rest of the vehicle system if not dealt with properly.
- **Energy storage systems:** These systems are a major challenge for HEVs and PHEVs. The pulsed power behavior and energy content required for the best performance are typically difficult for conventional batteries to satisfy. Life cycle and abuse tolerance are also critical for vehicle applications. Currently, nickel metal hydride batteries are used by most HEVs and lithium-ion batteries are targeted by PHEVs. Ultracapacitors have also been considered in some special applications where power demand is a major concern. Flywheels have also been investigated. The limitations of the current energy storage systems are unsatisfactory power density and energy density, limited life cycle, high cost, and potential safety issues.
- **Regenerative braking control:** Recovering the kinetic energy during braking is a key feature of HEVs and PHEVs. However, coordinating regenerative braking with the hydraulic/frictional braking system presents a major challenge as far as safety and braking performance are concerned.
- **Power management and vehicle control:** HEVs involve the use of multiple propulsion components that require harmonious coordination. Hence, power management is a critical aspect of vehicle control functions in an HEV. An optimized vehicle controller can help achieve better fuel efficiency in an HEV.
- **Thermal management:** Power electronics, electric machines, and batteries all require a much lower operating temperature than a gasoline engine. A separate cooling loop is necessary in an HEV.
- **Modeling and simulation, vehicle dynamics, vehicle design, and optimization:** Due to the increased number of components in an HEV, packaging of the components in the same space is a challenge. Associated vehicle dynamics, vehicle design, and modeling and simulation all involve major challenges.

## 1.8 The Invisible Hand—Government Support

Without government support, the HEV and PHEV may take a longer time to succeed in the marketplace due to their high cost and other limitations. As far as consumers are concerned, there are two kinds of buyers of HEVs. One kind expects to save money over time by saving fuel consumption, and the other buys the hybrid because of environmental concerns. The payback period, or the time it takes for the owner to recover the investment in an HEV due to fuel savings, depends greatly on the price of gasoline.

Take the Toyota Prius as an example. This HEV is priced at US\$22,800, while the conventional similar model, the Corolla, is priced at only US\$15,450. The MPG increases by 96% in city driving and 37% in highway driving. Assume that an owner annually drives an average of 10,000 miles in the city and 5000 miles on the highway. Then, the annual fuel consumption for the base model and for the hybrid will be as follows:

Conventional:	$10,000 \text{ miles}/26 \text{ MPG} + 5000/35 \text{ MPG} = 527 \text{ gallons}$
HEV:	$10,000 \text{ miles}/51 \text{ MPG} + 5000/48 \text{ MPG} = 300 \text{ gallons}$

At US\$2.50 per gallon, the fuel savings are US\$568 per year. In other words, it would take 13 years to make up the cost difference between the two vehicles. However, if gasoline were to cost US\$6.5 per gallon, it would only take 5 years to recover the cost differences.

Consider the Ford Escape SUV as another example. This HEV is priced at US\$29,860, while the conventional model is priced at US\$21,020. Assume an owner drives an average of 10,000 miles in the city and 5000 miles on the highway annually. Then, the annual fuel consumption for the base model and for the hybrid will be as follows:

Conventional: 10,000 miles/22 MPG + 5000/28 MPG = 633 gallons

HEV: 10,000 miles/34 MPG + 5000/31 MPG = 455 gallons

The total fuel saved is 178 gallons. At US\$2.50 per gallon, the fuel savings are US\$455 per year, so it would take 19 years to make up the difference. However, if gasoline were to cost US\$6.5 per gallon, it would take 7.5 years to recover the cost difference.

Government incentives can make a difference in this scenario. At this time in the USA Federal Tax Credits for new Plug-in Electric and Fuel Cell Electric Vehicles Purchased in 2023 or after is up To US\$7,500 and all-electric, plug-in hybrid, and fuel cell electric vehicles purchased new in 2023 or after may be eligible for a federal income tax credit of up to US\$7,500, depending on various factors including the vehicle's MSRP (manufacturer's suggested retail price), its final assembly location, battery component and/or critical minerals sourcing, and the buyer's adjusted gross income (<https://fueleconomy.gov/feg/tax2023.shtml>).

The latest situation on tax credit reads as follows in IRS website ([irs.gov](https://irs.gov)): "If you bought a new, qualified plug-in electric vehicle (EV) in 2022 or before, you may be eligible for a clean vehicle tax credit up to US\$7500 under Internal Revenue Code Section 30D. The credit equals:

- US\$2917 for a vehicle with a battery capacity of at least 5 kWh
- Plus US\$417 for each kWh of capacity over 5 kWh

The maximum credit is US\$7500.

A few states and metropolitan cities in the United States, such as California and Washington DC, allow access of HEVs to the high-occupancy-vehicle (HOV) lane. Due to the fact that a significant amount of time can be saved by driving in the HOV lane, some consumers are motivated to buy an HEV or PHEV for their daily commuting to save time.

Some other states, such as Colorado and California, have separate incentives in addition to those from the federal government. A number of private companies such as Google, Bank of America, STMicroelectronics, and Hyperion reward their employees for buying or leasing an HEV. It is interesting to note that the motivation of the companies toward such investment by their employees may be to allow them to spend time in the office rather than in traffic.

In 2009, the US president announced funding of US\$2.4 billion for PHEV development that supported 48 projects being undertaken by major car manufacturers and automotive suppliers. The projects support the development of batteries and electric drive components as well as the deployment of electric drive vehicles. The president of the United States set the goal of reaching 1 million plug-in hybrids by 2015. Additional incentives are in place for PHEV developers and consumers.

At the time of writing the first edition of this book, China, Japan, the European Union, and many other countries around the world have initiated support for the development, demonstration, and deployment of EVs, PHEVs, and associated battery and electric drive components.

However, hybridization of vehicles is not the ultimate solution for sustainability, though it builds the pathway to a sustainable future. The technology developed along this pathway will allow the necessary transition from fossil fuel-based transportation to ultimate electrification of the transportation sector.

Electrification alone will not provide sustainability. There will be a need for a coordinated effort along this critical path, including smarter urban planning, public transient systems, high-speed rail networks, and smarter and safer vehicles and roads. There will also be a need for a collective effort by multiple stakeholders. The power industry must increase its renewable energy and cleaner energy generation. Governments will need to develop fast rail transportation systems in and between dense metropolitan areas.

## 1.9 Latest Development in EV and HEV, China's Surge in EV Sales

At the time of writing the second edition of this book, there have been significant advances in the electrification of the automobile:

- HEV, EV, and PHEV sales are steadily increasing, with PHEV and EV sales significantly increased over the past five years. The US saw 114,022 EV and PHEV sales and 384,404 HEV sales in 2015.
- China sold 21.15 million passenger cars in 2015, including sedans, sport-utility vehicles, and minivans, a 7.3% increase from 2014, and sold 23.9 million cars in 2016, a 15.9% gain over 2015. This is less than the 10% and 16% gain in 2013 and 2014, respectively. It is predicted that China will see a 7.8% increase in auto sales in 2016, increasing to 22.76 million vehicles in 2016.
- China had the largest surge of EV sales due to its massive government incentives and sold more than 300,000 in 2015 (188,700 passenger cars and 124,000 electric buses) or 223% of the previous year's sales, not including more than 300,000 low-speed vehicle sales. (<http://cleantechnica.com/2016/03/08/china-electric-car-sales-increased-223-in-2015/> and <http://www.wsj.com/articles/china-car-sales-growth-slows-further-1452587244>). It sold 350,000 EVs and PHEVs in 2017, almost half of all EV/PHEVs sold in the world.
- A number of companies have gone bankrupt in the past six years, while EV sales have steadily increased, including EV maker Fisker Karma, lithium-ion battery maker A123, and battery swapping company Better Place.
- The oil price is maintained low, reaching below US\$30 per barrel in 2016, 80% down from its peak in 2008.

Historically, the high oil prices have spiked the interest in EVs. The current low price of oil will generate uncertainties for the future of EVs and HEVs, partly due to the low gasoline prices. Take the example in the previous section where the gasoline price was set at US\$3.30 per gallon and the cost to drive with gasoline was almost five times the cost to drive using electricity. With the gasoline price at US\$1.65 per gallon, the cost to drive a car using gasoline is only 2.5 times that of electricity. With an average of 15,000 miles per year, it will save US\$375 per year for a typical compact sized car. Therefore, if the incremental cost of EVs (including battery cost) is at US\$5000, it will take nearly 15 years to recover the initial investment. Hence, economically, EVs and HEVs become less attractive.

Government incentives can completely change the scenario. For example, in 2015, China sold more than 300,000 EVs. However, in the last three months of that year, they saw 75% sales of EVs compared to the total of EVs sold in the first nine months. This surge is due to the fact that some government subsidies were due to expire at the end of the year. In some cases, the subsidy will cover more than 90% of the selling price of the car. However, China will gradually reduce the government subsidies, at the rate of 20% per year starting in 2016, resulting in no or little subsidies for EVs by 2020. We will have to see how the market and consumers react to the reduction in subsidies.

On the other hand, Tesla, for example, has gained a lot of momentum in its EV sales, especially the much anticipated Model 3, which starts at just US\$35,000, compared to US\$75,000 for Model S. The Model 3 has already had more than 400,000 orders placed as of June 2016. But even with the sales volume realized, Tesla lost US\$889 million in 2015 and US\$282 million in the first quarter of 2016 [https://www.google.com/search?q=Tesla+lost+%24889+million+in+2015+and+%24282+million+in+the+first+quarter+of+2016.+&sca\\_esv=fd5281d190bdab12&hl=en&sxsrf=AE3TifNZUkfilFjbO2WUdbV\\_cwYJdH0QBA%3A1748804338462&source=hp&ei=8qI8aPS6Gcv0PEP8qyMoA8&iflsig=AOW8s4IAAAAAaDyxAlUAAI-KbMKuqnv8UdSn3Ub52Rzw&ved=0ahUKEwj0-3q89CNAXVLOTQIHXIWA\\_QQ4dUDCCs&uact=5&oq=Tesla+lost+%24889+million+in+2015+and+%24282+million+in+the+first+quarter+of+2016.+&gs\\_lp=Egndnd3Mtd2l6Ik9UZxNsYSBs3N0ICQ4ODkgbWlsbGlvbiBpbiAyMDE1IGFuZCAkMjgyIG1pbGxpb24gaW4gdGhlIGZpcnN0IHFIYXJ0ZXIgb2YgMjAxNi4gSABQAFgAcAB4AJABAjgBAKABAKoBALgBA8gBAPgBAvgBAZgCAKACAjgDAJIHAKAHALIHAlgHAMIHAMgHAA&scclient=gws-wiz](https://www.google.com/search?q=Tesla+lost+%24889+million+in+2015+and+%24282+million+in+the+first+quarter+of+2016.+&sca_esv=fd5281d190bdab12&hl=en&sxsrf=AE3TifNZUkfilFjbO2WUdbV_cwYJdH0QBA%3A1748804338462&source=hp&ei=8qI8aPS6Gcv0PEP8qyMoA8&iflsig=AOW8s4IAAAAAaDyxAlUAAI-KbMKuqnv8UdSn3Ub52Rzw&ved=0ahUKEwj0-3q89CNAXVLOTQIHXIWA_QQ4dUDCCs&uact=5&oq=Tesla+lost+%24889+million+in+2015+and+%24282+million+in+the+first+quarter+of+2016.+&gs_lp=Egndnd3Mtd2l6Ik9UZxNsYSBs3N0ICQ4ODkgbWlsbGlvbiBpbiAyMDE1IGFuZCAkMjgyIG1pbGxpb24gaW4gdGhlIGZpcnN0IHFIYXJ0ZXIgb2YgMjAxNi4gSABQAFgAcAB4AJABAjgBAKABAKoBALgBA8gBAPgBAvgBAZgCAKACAjgDAJIHAKAHALIHAlgHAMIHAMgHAA&scclient=gws-wiz)

The battery is still the bottleneck for EV penetration. Cost, energy density, durability, reliability, and safety are the major concerns for the currently available lithium-ion batteries. Other technologies, such as graphene material, which could potentially help to significantly increase battery energy density, are still to be further developed and validated. If indeed the energy density could be tripled or quadrupled in the next few years, and the cost could come down to one-third of the current cost, EVs would be more competitive than gasoline-powered cars.

It should be noted that at the time of writing this third edition of this book, the situation on EVs has significantly changed, compared to what existed in the past. For example, the latest customer demand suggests that people have become more reluctant to purchase full EVs. Rather, they are more interested in HEVs, PHEVs, and fully gasoline- or diesel-based ICEs. Apparently, the main reasons for this are range anxiety, the absence of sufficient infrastructure for charging, and the cost of replacing the battery in the EV for people who want to keep their vehicle longer than what is warranted in a new EV.

## References

- 1 Table 1060. State Motor Vehicle Registrations: 1990 to 2007, <http://www.statista.com/statistics/183505/number-of-vehicles-in-the-united-states-since-1990/> (accessed June 11, 2016).
- 2 China's Auto Sales Rebound in August after July's Monthly Decline, [http://news.xinhuanet.com/english2010/business/2010-09/09/c\\_13487102.htm](http://news.xinhuanet.com/english2010/business/2010-09/09/c_13487102.htm) (accessed June 11, 2016).
- 3 Owen, N.A., Inderwildi, O.R., and King, D.A. (2010) The status of conventional world oil reserves – hype or cause for concern? *Energy Policy*, 38, 4743. <http://dx.doi.org/10.1016%2F.enpol.2010.02.026> (accessed June 11, 2011).

- 4 US Oil Demand by End-Use Sector (1950–2004), [http://www.eia.doe.gov/pub/oil\\_gas/petroleum/analysis\\_publications/oil\\_market\\_basics/dem\\_image\\_us\\_cons\\_sector.htm](http://www.eia.doe.gov/pub/oil_gas/petroleum/analysis_publications/oil_market_basics/dem_image_us_cons_sector.htm) (accessed June 11, 2016).
- 5 International Energy Outlook. United States Energy Information Administration (2007) Petroleum and Other Liquid Fuels, May, <http://www.eia.doe.gov/oiaf/archive/ieo07/pdf/oil.pdf> (accessed June 11, 2016).
- 6 Williamson, S.S. and Emadi, A. (2005) Comparative assessment of hybrid electric and fuel cell vehicles based on comprehensive well-to-wheels efficiency analysis. *IEEE Transactions on Vehicular Technology*, 54 (3), 856–862.
- 7 Imai, S., Takeda, N., and Horii, Y. (1997) Total efficiency of a hybrid electric vehicle. Proceedings of the Power Conversion Conference, Nagaoka.
- 8 Rousseau, A. and Sharer, P. (2004) Comparing Apples to Apples: Well-to-wheel Analysis of Current ICE and Fuel Cell Vehicle Technologies. Argonne National Laboratory, [http://www.autonomie.net/docs/6%20-%20Papers/WTW/apples\\_to\\_apples.pdf](http://www.autonomie.net/docs/6%20-%20Papers/WTW/apples_to_apples.pdf) (accessed June 11, 2016).
- 9 Sanna, L. (2005) Driving the Solution – The Plug-in hybrid Vehicle, [http://mydocs.epri.com/docs/CorporateDocuments/EPRI\\_Journal/2005-Fall/1012885\\_PHEV.pdf](http://mydocs.epri.com/docs/CorporateDocuments/EPRI_Journal/2005-Fall/1012885_PHEV.pdf) (accessed June 11, 2016).
- 10 The Energy Report, <http://comptroller.texas.gov/specialrpt/energy/> (accessed June 11, 2016).
- 11 World Population, [http://www.google.com/publicdata?ds=wb-wdi&met=sp\\_pop\\_totl&tdim=true&dl=en&hl=en&q=world+population](http://www.google.com/publicdata?ds=wb-wdi&met=sp_pop_totl&tdim=true&dl=en&hl=en&q=world+population) (accessed June 11, 2016).
- 12 Annual Update on the Automotive Fuel Economy Program, <http://www.nhtsa.gov/cars/rules/CAFE/updates.htm> (accessed June 11, 2016).
- 13 The World Factbook, Oil Consumption by Country, [http://data.worldbank.org/indicator/EG.USE.PCAP.KG.OE?order=wbapi\\_data\\_value\\_2014+wbapi\\_data\\_value+wbapi\\_data\\_value-last&sort=desc](http://data.worldbank.org/indicator/EG.USE.PCAP.KG.OE?order=wbapi_data_value_2014+wbapi_data_value+wbapi_data_value-last&sort=desc) (accessed June 11, 2016).
- 14 Global, Regional, and National Fossil Fuel CO<sub>2</sub> Emissions, <https://www.osti.gov/biblio/1389331>