

1 Brackets and Bridges

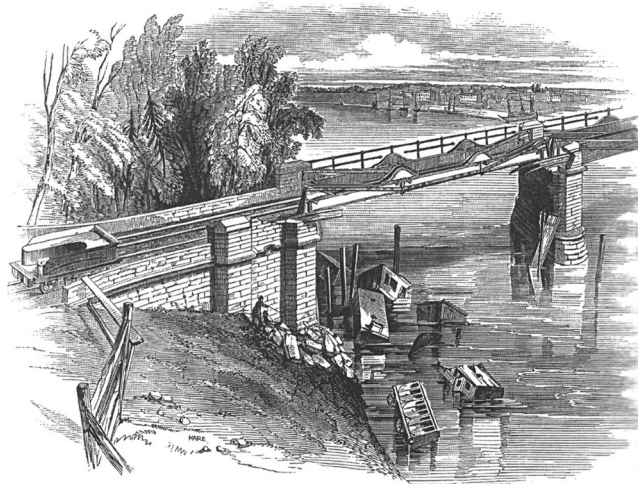

Figure 1.1 Failure of the Dee railway bridge, 1846.

When civil engineers in Canada graduate, they are given a steel ring, to be worn on the little finger of their writing hand, which identifies them as graduate engineers. No doubt those who wear it see it as a kind of badge of honour, but they should see it as a constant warning because traditionally it was made from the steel of the first Quebec railway bridge, which collapsed during construction. The warning is simple; no matter how experienced you might be as an engineer – and Theodore Cooper, the consulting engineer for the Quebec Bridge, was very experienced – you can still have a failure. When the Dee railway bridge collapsed in England in 1846 (Figure 1.1), it might well have destroyed the reputation of Robert Stephenson, then Britain's leading railway engineer. Instead, it led to a major enquiry because at that time the behaviour of iron railway structures was little understood. The same cannot be said of the Quebec Bridge – the story of its collapse is a human drama and a human tragedy. It involved no complex technical issues, as some engineering failures have, and Cooper's career ended in

How Structures Work: Design and Behaviour from Bridges to Buildings, Third Edition. David Yeomans.
© 2026 John Wiley & Sons Ltd. Published 2026 by John Wiley & Sons Ltd.

disaster rather than triumph. Most of the technical issues were very simple, with a structural type similar to the successful Forth Bridge, built just a few years earlier, so what could have gone wrong? To understand this involves understanding something of the process of design and having some very simple technical understanding of the structural principles involved. This collapse is an excellent introduction to the latter.

Cooper's tragedy

Theodore Cooper began his career as an assistant to another famous engineer, James Eades, on the St Louis Bridge, another very significant structure in the history of engineering. This elegant three-span arch bridge over the Mississippi River, completed in 1874, was the first all steel bridge; bridges up to then had been in cast and *wrought iron*. Cooper then had a long and successful career as a bridge engineer, but he had never built a really long span, so that his appointment by the Quebec Bridge Company as consulting engineer for a railway bridge over the St Lawrence River must have suited both him and the bridge company. The bridge company had the services of the leading North American bridge engineer, while Cooper had an opportunity to build what he would surely have seen as his crowning achievement. Instead, it was to be a disaster, and his career ended with a major failure instead of a record-breaking span. This was to be a cantilever bridge rather like the Firth of Forth Bridge, with cantilevers extending from either shore and a suspended span between them. With the south side cantilever completed and the suspended span under construction, the cantilever suddenly collapsed and over 80 men working on the bridge at the time lost their lives.

By then in his early 60s, Cooper had been reluctant to travel frequently from his New York office to Quebec to inspect the work in progress and instead relied upon the services of a young assistant, Norman McClure, just as Eades had relied upon him in the construction of the St Louis Bridge when he was a young man. Unfortunately, this assistant proved too inexperienced, or perhaps lacked sufficient self-confidence, and when things began to go wrong, there were conflicts of opinion in which his voice was insufficiently firm. But at the same time, all was not well within Cooper's office. He was understaffed for the magnitude of the task so that the true situation was not appreciated. The result was fatal delays in taking the action that might have prevented the collapse and saved those lives.

Of course, failures are not unknown. There had been bridge failures before, and there were to be failures to follow, but of the most famous failures, that of the Quebec Bridge stands out because it did not involve any principles that were unknown at the time, something that has not been true of some other significant collapses. The Dee Bridge on the Chester and Holyhead Railway collapsed when a train was crossing it and there was some loss of life. This bridge used a combination of wrought and cast iron in a form that had been used on other bridges but was in principle simply wrong. What was significant about that collapse was that it led to a government enquiry into the use of cast iron in railway bridges. Railway construction then involved longer spans than had been built before and much heavier loads so that engineers were stepping into unknown territory. While the design of this bridge was wrong in principle, it was not obvious to engineers at the time that this was so, and the report of the commission of enquiry provides a good insight into contemporary engineering knowledge.¹ Stephenson's career

¹ *The Report of the Commissioners appointed to inquire into the Application of Iron to Railway Structures*, 1847.

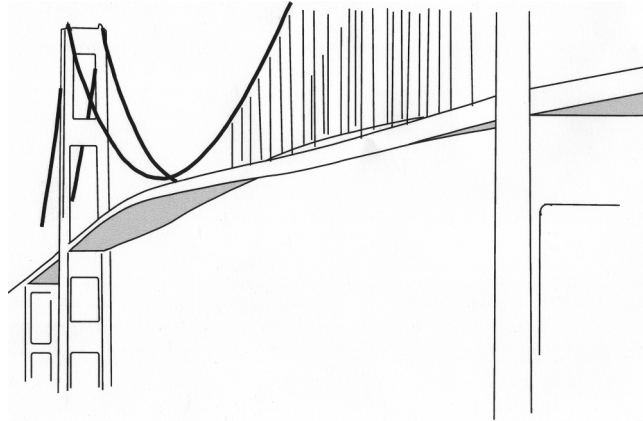

Figure 1.2 Tacoma Narrows Bridge twisting in the wind.

survived this failure, and he went on to complete the spectacular Conway and Britannia tubular bridges on the railway line to Holyhead and the Victoria Bridge over the St Lawrence at Montreal.

Sir Thomas Bouch was not so lucky when his Tay Bridge collapsed in a storm in 1879, taking with it a train and the lives of all those on board. The bridge had scarcely been completed, and the inquiry into that disaster revealed a story that included poor construction and irresponsible use by the engine drivers who were in the habit of ignoring the speed limit and racing the ferry across the river.² But it also became clear that Bouch had not taken wind loads into proper account in his design. This was not something that bridge engineers had taken much note of until then, but the failure now concentrated minds on the issue, and it was certainly taken into account in the design of the Forth Bridge.

It was wind that was also to bring down the Tacoma Narrows Bridge in 1940, although it was not a particularly severe wind that caused the problem, nor was the bridge a particularly long span. It was, however, the most slender suspension bridge that had been built up to that time, and the wind produced aerodynamic effects that had not been previously recognised. Because of its slenderness, it twisted in the wind (Figure 1.2) in a way that exaggerated the effect of what became known as vortex shedding, until the bridge was destroyed. The replacement bridge was made much stiffer, and since then engineers have been aware of the need to guard against this kind of failure, sometimes using wind tunnel tests to explore the behaviour of their bridge decks.

These three failures all occurred when engineers were pushing at the boundaries of what was then known. When buildings are built higher, or bridges have longer spans, there is always the possibility that one will discover some aspect of the structure's behaviour that was not previously recognised. But the span of the Quebec Bridge was not that much greater than that of the Forth Bridge, less than 10% longer, so that should not have been an issue. What Cooper also did, however, was to design for higher stresses in the steel than had been used previously, something that will be dealt with in more detail later in the chapter, and this in part was his undoing. But the structural issues come down to too much load on members that were too weak – and it is the reason for this that needs to be explained.

² *The Inquiry into the Tay Bridge Disaster*, 1880. For a popular account of this, see Preeble, John, *The High Girders*, Secker and Warburg, London, 1966.

The Forth Bridge

In building a bridge across a wide body of water, an engineer has to balance two difficulties: the difficulty of having a long span (or several long spans) and the difficulty of making foundations in the river. The simplest iron or steel bridge structure is just a series of girders resting on piers. The ill-fated Tay Bridge had been just that, and so is its replacement that is still in service today, but these designs required a great many piers and so a great many underwater foundations. When Baker came to bridge the Firth of Forth, he chose to limit his foundations to shallow water and an island and build gigantic cantilever structures to span across the gaps between them (Figure 1.3). A cantilever is a structure that is supported at one end only, unlike a beam, which is supported at both ends. A simple example is a shelf bracket, but Baker's design involved cantilevering out in both directions from each of the supports, double cantilevers, like brackets fixed back to back.

To explain this design, Baker made a now famous demonstration to show exactly how it would work. He had his assistant, Kaichi Watanabe, sit on a board to represent the weight of one of the suspended spans supported between the cantilevers. The board was supported by a pair of inclined wooden struts while two men sitting on chairs with their arms held out grasped the ends of these struts. The men, their arms, the struts and the chairs they sat on represented these massive double cantilever structures, and, with counterbalancing weights, they were able to support the weight of Baker's assistant on the suspended board.

This has become such a well-known demonstration because we can all understand it by imagining the forces in our own bodies if we were one of the men sitting on the chairs helping to support Watanabe's weight. The wooden struts must be there pushing upwards or the men would not be able to hold their arms out to support his weight. Their arms must be holding the ends of the timber struts and pulling inwards on them or these struts would collapse downwards, rotating about their supports. The counterweights at either end must be there or the two men, the struts and their chairs would topple into the centre.

Figure 1.4 is based on the photograph of the time, reducing it to a simple line drawing, but we could reduce it still further to a diagram of forces, by simply removing the drawings of the men and leaving the lines representing the forces. That is how engineers represent structures. In the diagram, Watanabe's weight is represented by an arrow that pushes downwards on the suspended board. The struts are pushing upwards against this weight, and the forces in these struts can also be represented by arrows. As they push upwards against the board on which Watanabe sits, they push downwards on the chairs, but they also push outwards against the hands of the men holding them and whose arms pull inwards against this force. Again, arrows represent the forces in the men's arms: they pull inwards on the ends of the struts but at the same time are pulling on their shoulders in the other direction. Of course, the counterweights produce similar forces on the other side of the men, and adding more arrows there completes

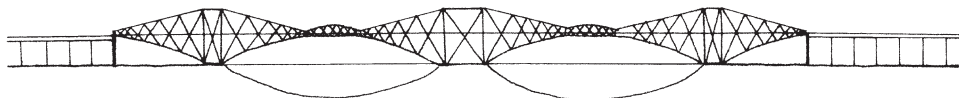

Figure 1.3 The Forth Bridge.

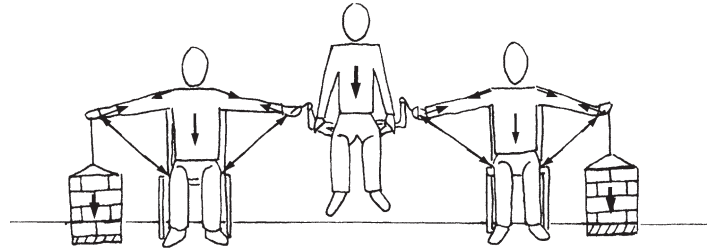

Figure 1.4 Baker's demonstration of the Forth Bridge.

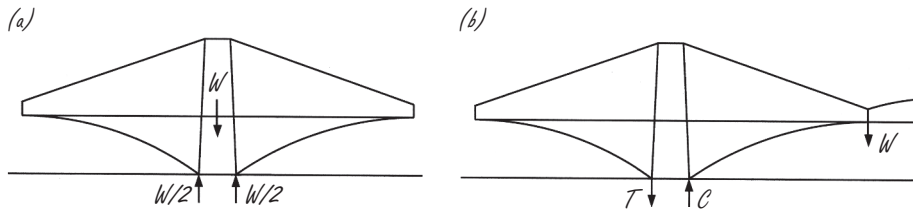

Figure 1.5 The cantilever support forces with (a) self-weight alone and (b) load of the suspended span alone.

a diagram of forces within the demonstration structure (ignoring for the moment the forces in the men's bodies and their own weight). All that is now required is to add in the upward forces from the ground under the chairs because all structures are eventually supported by the ground.

Rather than do that with Baker's demonstration, we can do it with a diagram of the structure of the bridge. The cantilevers were built first; Figure 1.5a shows what the structure looked like before the suspended spans were added, the weight of the structure being equally distributed across the foundations.

In the demonstration, Watanabe's weight is balanced at either end by heavy weights, and the simple diagram of the bridge shows why these were needed. If the main structure weighed nothing, a suspended span would put a load on the ends of the cantilever arms that, if not counterbalanced by some weight on the other side, would lift the structure off the opposite foundation and it would have to be tied down – as shown by the arrow marked T. The weight of the main structure itself and the span on the other side prevent this from occurring.

We can see from this that there are two ways of looking at a structure. We can consider its overall behaviour, as in Figure 1.5, and think about the forces at the ground that are necessary to support it, or we look at what is happening inside it, as in Figure 1.4, looking at what happens at the ends of each member. This second way of thinking about a structure, taking each of the joints between members in turn and imagining which way each member is pulling or pushing at it, is a fairly standard way of analysing a structure and drawing the forces in it. Notice that apart from the applied loads, Watanabe's weight and the two counterweights, the other forces, those in the members of the structure, are in pairs. The arms have pairs of arrows pointing inwards, and we know that the arms are in tension as they pull inwards. The timber struts have pairs of arrows pointing outwards, and we know that these are in compression as they push outwards and upwards. Tension involves pulling and compression involves pushing.

Some grammar - actions and reactions

At this point it is appropriate to introduce a little grammar in the form of a term that we shall need later. The forces shown in the arms of the men and the timber struts would not exist if it were not for the loads that have been applied: Watanabe's weight on the suspended span and the counterweights. These loads are sometimes referred to as *actions* upon the structure, the forces generated in the members being *reactions* to them. This calls into mind Newton's third law, that for every action there is an equal and opposite reaction. This equality of action and reaction might not be so apparent here but we shall see how that works in the next chapter. Also note that because the word 'load' is so commonly used we shall continue to use it so that the forces generated in the structure are reactions to the applied loads.

Note that the arrows representing forces in the members show the action, or reaction, at their ends. Struts, which are members in compression thrust outwards. Ties, which are members in tension pull inwards. This is discussed in more detail in Chapter 4.

Baker's design for the Forth Bridge required three of the double cantilever structures. The suspended spans between them were simple girders, and we shall look at how they work in the next chapter. The tension members of the cantilevers are straight lattice members, while the lower compression members are curved tubes. As the structures were cantilevers, once the foundations in the river had been completed and the central support structure erected above them, the equivalent of the chairs and the bodies of the men, the cantilevers could be built out on either side. At every stage, the weight on one side of the central support would be balanced by the weight on the other. Moreover, the cantilever arms would be working exactly as they would when the bridge was completed, that is, with the top members in tension and the bottom in compression. Sometimes, the forces in a structure during construction are different from those once it is completed, and that was so for the girders spanning between the cantilevers. They were designed so that when completed, they would span like beams between their ends, but they were built by cantilevering from the ends of the main cantilever structures. When they met in the middle, they could be joined together to form a beam. How exactly that was done need not concern us here; sufficient to say that it was successfully accomplished at the Forth, but over the St Lawrence, it was while this suspended span was being constructed that the collapse occurred.

Members in compression

The collapse at Quebec occurred because of failure of compression members. Members in compression cannot be made too small or they will collapse through *buckling*, something that can easily be demonstrated with some simple struts; garden canes will serve the purpose. Take a long thin garden cane and load it in compression. The cane will bend sideways under this load, as shown by the dotted lines in Figure 1.6, and if enough force is applied, it will eventually break. One can readily imagine that if the struts of Baker's demonstration were

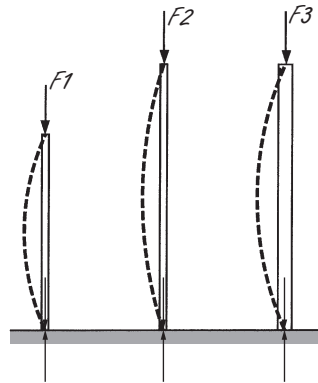

Figure 1.6 Column buckling.

made progressively smaller, they would eventually collapse in the same way. Some simple experiments illustrate how the properties of a column affect the load that it can carry – changing the length of the cane, for example. Garden canes are sold in different lengths and thicknesses. By cutting canes down to the lengths we want we can have two thin canes of different lengths and two long canes of different thicknesses. By applying loads to the ends of these until they buckle, it will immediately be apparent that the longer the cane, the smaller the force that has to be applied to produce this buckling effect. The long thin cane will buckle under a smaller force than the short cane of the same thickness. A thicker cane of the same length will take a much larger load before buckling occurs.

If the forces shown in Figure 1.6 are those that cause the cane to buckle, then F_2 is less than F_1 (normally represented as $F_2 < F_1$) because the second cane is longer. But as the third cane is thicker than the second, F_2 is less than F_3 ($F_2 < F_3$). (The symbol $<$ is read as ‘less than’, while the symbol $>$ is read as ‘greater than’.)

Garden canes are almost solid circular columns and can bend just as easily in any direction. If a thin lath were used instead, it would bend about the narrow dimension, and if this were progressively reduced, it would eventually be unable to support even its own weight, just as a piece of paper cannot. Since a lath always buckles about its smaller dimension, we might reasonably assume that a symmetrical section was the most efficient as a column, that is, for the same cross-sectional area, a square column would be better than a rectangular one. For a given cross-sectional area of material, a circular tube is the best shape for members in compression, something that one might demonstrate by rolling a piece of paper into a tube. A sheet of paper that cannot support its own weight can be easily folded into a square tube or taped to make a circular one and will then stand upright and might even be made to carry a small load.

In Figure 1.7, a column shaped like ‘a’ will carry more weight than ‘b’ although both have the same cross-sectional area and so will have the same compressive *stress* for the same load. Column ‘c’ has twice the cross-sectional area of the other two but will carry more than twice the load of ‘a’ simply because of its shape.

This shows clearly why tubes were used for the compression members of the Forth Bridge. The tension members at the top of the cantilevers are built up to the required size as square lattices with rolled angle sections riveted together. This would have been the simplest way of

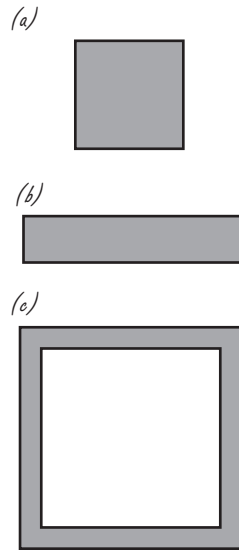

Figure 1.7 Column cross sections of equal area.

building up sufficient material to carry the forces. In contrast, the tubes of the compression members at the bottom would have been more difficult to make but were known to be much more efficient in carrying the compressive load. The diagonal members between these are also tubes in one direction but lattices in the other so it is clear that the designer intended one set to work in compression while the others worked in tension.

The Quebec Bridge

The original design for the Quebec Bridge produced by the Phoenix Bridge Company was for a span of 1600 ft (480 m), but Theodore Cooper recommended increasing the span to 1800 ft (540 m), the intention being to move the bridge piers into shallower water, which would speed construction and so reduce the costs. This was important in a river that froze in winter, and it was a sensible suggestion, although all involved were aware of the fact that it would make the span greater than those of the Forth Bridge and therefore set something of a record; as such, it would have been a fitting culmination to Cooper's distinguished career as a bridge engineer. The eventual dimensions are shown in Figure 1.8. The central span was to be 675 ft (205.74 m) with the cantilever arm supporting it 562 ft 6 in. long (171.45 m). The landward cantilever span, called the anchor span, was slightly smaller at only 500 ft (152.4 m). Unlike the Forth Bridge, where lattice girders were used for the tension members, the Quebec Bridge used much simpler eye bars for the top *chord* of the cantilevers and the diagonal tension members. These are flat bars with holes at either end through which there were pins to join the bars together. Each 'member' would be built up from a number of such eye bars. The compression members comprised plates built up to form four flats then connected together with a lattice to make them all act together, rather than the tubes that Baker had used. From

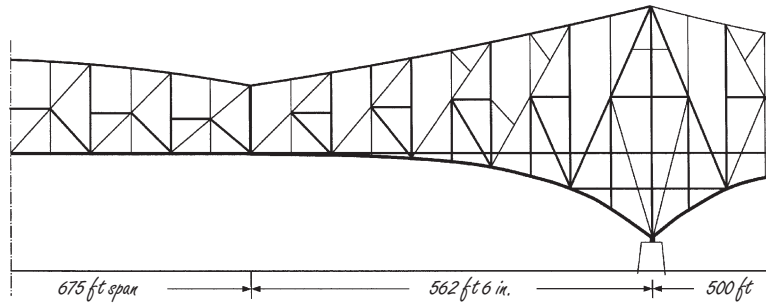

Figure 1.8 Quebec Bridge showing dimensions.

what has been said, this might seem a strange decision. It is clearly not as structurally efficient as tubes but easier to make.

There had been some warning of the impending failure because deflections of the compression members had been noticed by McClure, who was overseeing the construction on Cooper's behalf, but his concerns were not acted upon. This was partly because of differences of opinion about the cause of the deflections, partly because of poor communications between the parties involved, and also because of lack of adequate authority on site. Cooper was in his office in New York and only receiving letters from his young assistant, expressing his concerns. The Phoenix Bridge Company, who were making the components for the bridge, claimed that what McClure saw as deflections in the members was simply because the members were not quite straight when brought to the bridge. But deflections measured on different days had shown that they were increasing: the bridge was already beginning to collapse. At one stage, the foreman of the construction crew had become concerned about the state of the structure and ordered his men off the bridge but was then persuaded to let them back. Eventually McClure travelled to New York to discuss his concerns, and it then became clear that the weights of the suspended span that was in the process of being built was too great for the strength of the cantilevers. It seems that the weight had crept up in part because the connections between the members proved larger and therefore heavier than had been anticipated. Last-minute instructions from Cooper to stop work so that no more load was put on the structure arrived too late, and at the end of the shift on August 29, 1907, the compression members on the south anchor span failed. Of 88 men on the bridge at the time, only 11 survived the collapse.³

Forces in a bracket

The forces on the compression members were clearly larger than the members could have withstood, so either there was an error in calculating them or Cooper had been optimistic about the stresses that the steel could carry. Whatever the strength of the steel, there was

³ This can only be a brief account of the collapse. For a fuller account, see Eda Kranakis, 'Fixing the Blame: Organizational Culture and the Québec Bridge Collapse', *Technology and Culture* 2004:45.3; 487–518; and William D. Middleton, *The Bridge at Québec*, Indiana University Press, Bloomington, IN, 2001.

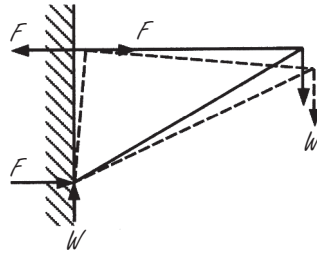

Figure 1.9 The virtual movement of a bracket under load.

certainly an error in calculating the forces in the members, but this requires some explanation because it is not a difficult figure to find. If we knew the weight that the cantilever had to carry we could estimate the forces ourselves. Cantilever bridges are rather like shelf brackets writ large, and most of us have had some experience of putting up a shelf bracket, and perhaps having one fail, when the forces acting become only too apparent.

To fix a bracket to a masonry wall, holes are first drilled in the wall to take the fixings. These take the form of plugs, nowadays made of plastic, with screws fixing the bracket to them. Each screw grips the plug but also forces the plastic against the sides of the hole in the masonry to develop the friction forces that hold it in place. But it is not always as simple as that. Sometimes, perhaps if we drill into soft mortar rather than into a brick, the top fixing fails, pulling out of the wall and allowing the bracket to rotate about the bottom fixing. The dotted lines of Figure 1.9 show the movement that will occur.

This failure clearly shows the forces involved, and imagining the mechanism of failure is a useful way of understanding most structures. If it fails, how will it fail? In which direction will it move? Therefore, what forces are required to prevent this movement? We can see from the bracket failure that the load on the end of it is trying to rotate it one way about the lower fixing (clockwise in the drawing), while the force in the upper fixing is trying to prevent this with a force that is producing a rotational effect in the other direction (counterclockwise). The two forces are different in magnitude, but if the bracket is successfully fixed, they must be producing equal but opposite rotational effects about the bottom fixing.

The forces are of different magnitude because their distances from the pivot are different. This is something that we should be familiar with. It occurs when a parent balances their child on a see-saw. The parent has to sit closer to the pivot than the child in order to balance the see-saw simply because of the difference in their weights. If the weights and distances are represented by their initial letters, then a large **W**eight multiplied by a small **d**istance is balanced by a small **w**eight multiplied by a large **D**istance, that is, $W \cdot d = w \cdot D$ ($W \times d = w \times D$) (Figure 1.10). This is exactly the arithmetic of the bracket and the bridge. The turning or rotational effect of a force about a point is called the *moment* of the force, that is, 'moment' = 'turning effect', and it is convenient to use this word simply to avoid the longer two-word phrase. The moment (turning effect) of any force about a point is simply the product of that force and its distance from the point in question, sometimes called its lever arm (often but not always the pivot about which it might rotate). Notice that to complete the diagram of forces, the force at the pivot has been included. Ignoring the weight of the see-saw itself, this must be the sum of the weights of the two people sitting on it.

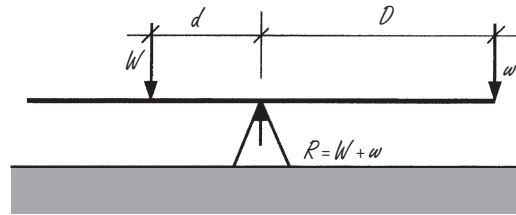

Figure 1.10 The forces on a see-saw.

The steelyard

There is a measuring device called a steelyard that uses just this principle. As heavier loads are placed upon it so the moveable weight has to be slid further along the arm to balance the device. Weights placed on the pan are indicated by distances along the arm.

On one side there is an unknown weight W at a fixed distance l from the pivot while the fixed weight, w , is at a variable distance x from the pivot. The product $Wl = wx$.

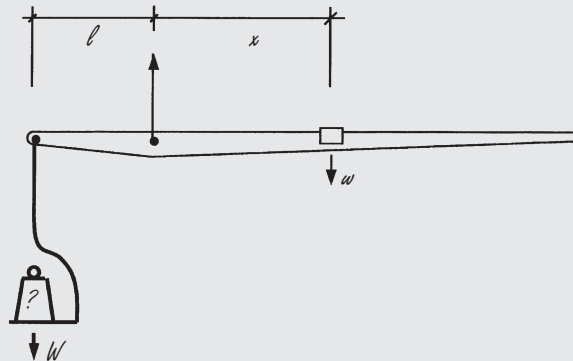

Figure 1.11

In the see-saw and the steelyard, all the forces are vertical and the structure connecting them is a simple beam, whereas in the bracket one of the forces is horizontal and its distance from the point about which rotation is occurring is measured vertically up the wall (Figure 1.12a). Nevertheless, the principle remains the same. If the horizontal force is represented by the letter F and the height of the bracket by the letter h , then $Wl = Fh$, precisely the same arithmetic as the see-saw. The bracket also has the same forces in it as the cantilever bridge, although one of the members is horizontal and the other inclined. The lower member must be in compression pushing out on the end of the upper member and inwards on the wall. The upper member is pulling inwards on the end supporting the load and outwards on the wall. There also needs to be an upwards force at the wall to balance the downward force of the load on the end of the bracket.

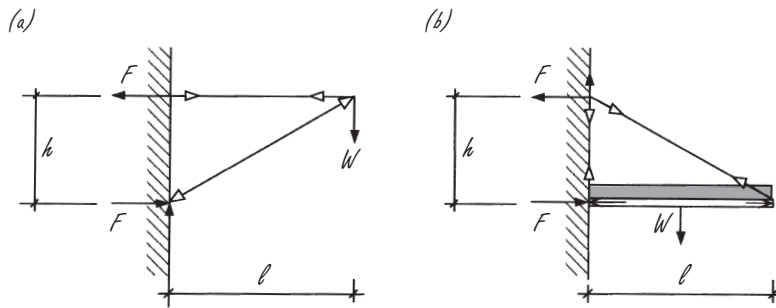

Figure 1.12 Two different brackets.

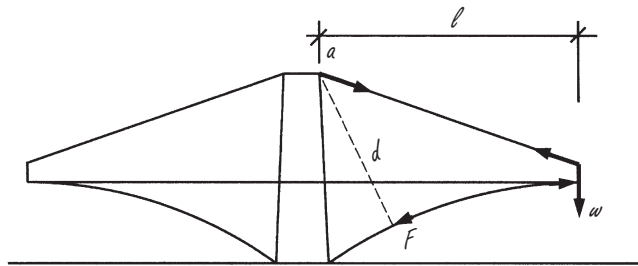

Figure 1.13 Principal forces in a bracket of the Forth Bridge.

Anyone who has difficulty with this might usefully read the first few pages of Chapter 8, which describe the process of putting up a ladder. This is the closest that we come to experiencing ourselves the effect of moments of forces with the forces in different directions.

Before leaving the simple bracket, we should note that there is another way of arranging the forces. In Figure 1.12b, a wooden shelf is assumed to be supported by a simple loop of string at either end. The string passes under the shelf, up the wall to some fixing and then down to the front of the shelf. The weight on the shelf is represented by the shaded area, and we can assume that it acts in the middle of the shelf as shown. The string is naturally in tension, nothing else is possible, and it is the shelf that is providing the compression force at the bottom. If the weight to be carried is the same as before and the geometry is the same, the forces at the wall are half of the forces in Figure 1.12a simply because the weight has shifted inwards to the middle of the shelf.

In the Forth Bridge, and in the design for the original Quebec Bridge, both of the bracket members are sloping and the lower member is curved. The latter, an aesthetic decision, complicates things a little, but we can still treat the structure like a simple bracket. The compression in the lower member can be found if we know the weight of the suspended span and the geometry of the structure. In this case, to find the compression in the lower member, we need to consider moments about the top of the bracket, the point marked 'a' in Figure 1.13. This point rather than the bottom is considered as the pivot. The weight on the end of the bracket multiplied by its length is balanced against the force in the compression member multiplied by its distance from the pivot. Note that the distance is measured at right angles to the member, something that will be dealt with in more detail in Chapter 8. The horizontal line simply

represents the internal viaduct, which plays no part in carrying the load of the suspended spans. In fact, it places additional loads on the structure, which for the moment we shall ignore.

It is possible to turn the verbal description into a simple equation. If the span is l and the load on the end of the cantilever is W , then the moment about a is $W.l$. The resisting moment is the force in the bracket multiplied by its lever arm d , so that $F.d = W.l$ and therefore (dividing both sides by d) $F = W.l/d$.

If the calculation is that simple, then how was it that Cooper got it wrong? The answer to that is that he did not know accurately enough the weight of the suspended span, that is, the magnitude of the weight W . Of course, it was a little more complex than that because there was also the weight of the cantilever itself, which doubtless had also been underestimated, but the overall principle is the same. To understand how that happened, we need to look at the process of the design.

The design process

‘Begin at the beginning,’ the King said, gravely, ‘and go on till you come to the end: then stop.’

Alice’s Adventures in Wonderland

If only it were that simple. Just as the design of the Quebec Bridge demonstrates a small number of structural principles, it also shows some of the features of engineering design. The principal cause of the collapse was the failure of the engineers to make a proper estimate of the weight of the suspended span. While the function of a bridge is to carry some load across a gap, a great deal of what it is carrying is its own weight, which may be many times that of the load to be imposed upon it. The ideal is to start at the top and work down so that one knows the weight of each part before designing the structure to carry it, but the engineer cannot always do that, as the case of the Quebec Bridge shows. Any structure is built from the foundations up so that the first things required by the contractor are the drawings for the foundations, ideally the last thing to be designed – but engineering designs are seldom carried out under ideal conditions.

The Quebec Bridge Company was initially short of funds, but when it was eventually known that there would be funds for the bridge it wanted work to start as soon as possible – it is always thus. As so often happens, this means that detailed design and construction are proceeding at the same time. How then are we to be sure that the overall design is adequate, especially in a bridge where most of the load to be carried is its own weight? The answer is to make a guess – or rather an estimate, which is the word that engineers prefer to use.

Making an estimate like this might seem to be a rather crude way of determining the forces in a structure, but it is something that engineers often do and is an essential part of the design process. In the early stage of a design the engineer has some ideas of what forms the structure might take and wants to know whether or not any particular idea is practical. Will it result in acceptable forces that can be accommodated or will they simply be too large? The engineer will probably have more than one idea and would like to compare them. To do this what is needed are simple ‘back of an envelope’ calculations just to give some idea of the forces involved. Such calculations might quickly rule out some impractical ideas, hence the

engineering adage that 'a job worth doing is worth doing badly'. Of course, the estimates used for such calculations are important, and if they are wrong, there can be problems later in the design process as the engineer has to find ways of dealing with unexpectedly large forces.

A similar process is carried through into the design proper as estimates are made of the foundation loads on the assumption of the weights of the superstructure. One of the more recent buildings where this caused a serious problem was in the design of the Sydney Opera House. It was originally assumed that this would comprise relatively thin shell structures and the foundations were designed on the basis of the weights of such shells. In the event, that was not possible and a much heavier structure based on arches was adopted. Thus, the already constructed foundations had to be strengthened.

There is clearly a certain amount of engineering judgement in such early estimates, dramatically demonstrated by the Quebec Bridge failure. The superstructure of the Quebec Bridge can be divided into two parts, the structure of the cantilevers and that of the suspended span between them. Just as the foundations had to be designed before the superstructure, so the cantilevers had to be designed before the designs for the suspended span were completed. Therefore, the cantilever design had to be based upon an estimate of the weights coming onto them. As the design proceeds, the calculations should be refined, but, in this case, even though the suspended span had been designed and was being constructed, no one had checked the weights to compare them with the original estimate, which in the event proved disastrously low. With detailed design and construction pressing ahead after initial delays, accurate figures were not produced until rather late, and it was only when McClure had pointed out the buckling of the members that mistakes were realised. Long before Cooper sent the telegram ordering work to be stopped so that no more load should be put on the cantilevers, the latter were already carrying a much larger load than the structure was designed for.

Stresses

The problem was exacerbated by Cooper's assumption of high stresses in the steel. The question is: how much stress will a material carry before it fails? It is possible to ensure low stresses simply by using more material, but one of the definitions of an engineer is someone who can do for a shilling what any fool can do for two. The idea is to use as little material as possible. As the Quebec Bridge Company was short of funds, Cooper, as well as increasing the span, proposed to allow high stresses in the steel as an economy measure. By designing for a higher stress, he reduced the quantity of material needed and so saved money, and as this is such a central aspect of engineering design it is sensible to tackle the definition of stress.

If we stand on a piece of blackboard chalk it will crush under our weight, but use a block of chalk large enough and it will carry our weight. It is not the force that a material carries that causes it to fail but the stress within it, which is defined as the force per unit area. If we wanted to suspend a heavy load, we would all be aware that it would be better to use a steel wire than a piece of string of the same diameter. The steel wire would be capable of carrying a higher stress and therefore a greater load. Figure 1.14 shows how stress is measured. The column has a compressive force in it that is acting along the column. The area, A , the cross-sectional area of the column, is at right angles to the direction in which the force is acting and the stress is the magnitude of the force divided by this area. The stress is simply the load

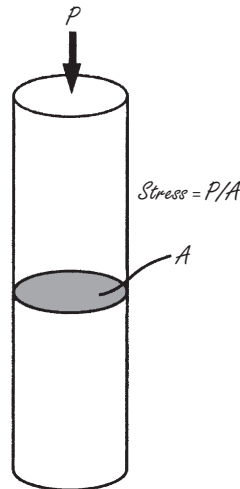

Figure 1.14 Stress.

divided by the area of material that is carrying it. In Figure 1.14, the weight on the column exerts a force P on the column, which has a cross-sectional area A . Therefore, the stress in the column is simply P/A .

If the engineer begins by knowing the forces in a member, the question is then how much stress might be safely allowed in the material that is to carry that force, something that is found by loading materials to failure. The results provide the data that engineers use for sizing the members of their structures. The problem is a little more complex than that because excessive deflection might be regarded as a failure. Also, as we have already seen, failure of long members in compression occurs because of buckling, which involves a more complex calculation of behaviour than we can deal with here. Nevertheless, the allowable stress is still the place to start.

At the time of the construction of the Quebec Bridge, steel was still a relatively new material in structures. True it had been used by Eades, Cooper's former employer, on the St Louis Bridge, but the tendency had been to use the same safety factors for steel as those that had been used for wrought iron.⁴ If higher stresses could be allowed, then the quantity of steel used, and hence the cost, would be reduced. This was Cooper's strategy, but here, he was sailing into the unknown and seems to have gone beyond what other engineers were to regard as prudent. When the bridge was redesigned, both lower stresses and a different profile were used, resulting in a much greater weight of steel. But there was also the form of the compression members that did not behave as assumed. Tubes were more difficult to fabricate, but the lattice joining the steel flats together was inadequate for its task. The collapse led to concerns about the design of the Queensboro Bridge, New York, which was then under construction; consequently, its loading was reduced by having fewer train tracks across it than originally intended. Engineers either learn by their own mistakes or by the mistakes of others.

⁴ Pugsley, Sir Alfred, *The Safety of Structures*, Edward Arnold, London, 1996, pp. 34–35.