

Chapter 1

Exploring the World of Electronics Projects

In This Chapter

- ▶ Understanding exactly what an electronics project is
 - ▶ Exploring the effects you can achieve
 - ▶ Considering what's in it for you
 - ▶ Determining what you need to invest to get started
-

You probably picked up this book because you love tinkering with gadgets, from that train set you got as a kid to the motion-activated dancing monsters on display in the store aisles at Halloween. Not only are you intrigued by them, but you wonder whether you can build something like them yourself. Now that you own this book, yes, you can!

In this chapter, we take a look at exactly what getting into building electronics projects involves, the kinds of great gadgets you can build yourself, what you'll get from spending your time with electronics, and what you need to commit to take the plunge.

What Is an Electronics Project, Anyway?

Obviously, an *electronics* project involves electronics, meaning that you use electricity to make something happen. However, overlaps exist among electronics, mechanics, and even programmable devices such as robots. Here's what we mean when we say *electronics projects*.

Electronics, mechanics, robotics: Huh?

Do you dream of building elaborate Erector Set-types of mechanical structures — perhaps a model of the Golden Gate Bridge with pulleys and levers moving objects around? Is your goal to create a robot butler with a programmed brain that enables it to serve your every whim? Well, those aren't exactly what we categorize as electronics projects.

Certainly, electronics projects are often combined with mechanical structures that use motors, and a robot has electronic components driven by microcontrollers and computer programs. In this book, though, we focus on projects that use simple electronics components to form a circuit that directs voltage to produce effects such as motion, sound, or light. By keeping to this simple approach, you can pick up all the basic skills and discover all the common components and tools that you need to work on a wide variety of projects for years to come. For these projects, you don't have to become a mechanical or programming whiz.

An electronic circuit might run a motor, light an LED display, or set off sounds through a speaker. It uses various components to regulate the voltage, such as capacitors and resistors. A circuit can also use integrated circuits (ICs), which are teeny, tiny circuits that provide a portion of your circuit in a very compact way. This saves you time micromanaging pieces of the project because somebody else has already done that job for you, such as building a timer chip that sets off a light intermittently.

Programmable versus nonprogrammable

ICs are preprogrammed or programmable. And that brings us to our next distinction.

Although we do use ICs in many of our projects — for example, in the form of a sound chip that's preprogrammed with beeps and music — for the most part, we keep away from programmable electronics. In order to work with programmable electronics, you have to get your hands dirty with programming code and microcontrollers, and that's not what we're about here. Instead, we focus on building electronics gadgets that teach you about how electricity works and get your mind stirring with ideas about what you can do by using electronics, rather than computers.

Don't get us wrong: Microcontroller projects can be a lot of fun. After you get your hands dirty and pick up lots of basic skills doing the projects in this book, you might just go out and buy *Microcontroller Projects For Dummies* (if such a book existed).

Battery-powered versus 120 volts+

One other thing that we made a conscious decision about when writing this book was that we didn't want you tinkering with high-voltage projects. Electricity can be dangerous! Keeping to about 6 volts keeps you reasonably safe whereas working with something that uses 120 volts — like the juice that comes out of your wall socket — can kill you. While you're discovering the basics of electronics, our advice is that it's better to be safe than sorry.

When you get more comfortable and more knowledgeable about tools and skills and safety measures (which we put a lot of emphasis on, especially in Chapter 2), you might explore higher-voltage projects such as high-powered audio or ham radio projects. In this book, we show you how to work with low-voltage batteries and still have fun in the process.

Mixing and Matching Effects

The possibilities of what electronics projects can do are probably endless; on a basic level, the projects in this book use electricity to do a variety of things, from running a small cart around the room to setting off a sequence of lights or sounds.

Generally, most electronics projects consist of four types of elements:

- ✔ **Input:** This sets off the effect, such as a remote control device or a switch that you push. An event and a sensor, such as a motion or light detector, can also be used to activate an effect.
- ✔ **Power source:** We typically use batteries in these projects.
- ✔ **Circuit:** Components that control the voltage — such as transistors, capacitors, amplifiers, and resistors — are connected to each other and to the power source by wires and make up the circuit.
- ✔ **Output:** This is what is powered by the circuit to produce an effect, such as speaker emitting sound, LED lights going off, or a motor that sets attached wheels spinning.

What Can You Do with Electronics Projects?

You get to explore a number of variations in the projects in this book. And sure, this stuff sounds like it might be cool, but what's in it for you? Electronics projects offer three benefits (at least):

- ✓ Fun
- ✓ The thrill of making something work all by yourself
- ✓ A boatload of useful knowledge

Just for the fun of it

One obvious benefit of tinkering with gadgets is that it's just plain fun. If you're the type who's intrigued by how things work and what's under the hood, you probably already know this.

In fact, we have lost ourselves for hours figuring out circuits (this is the electronics equivalent of a jigsaw puzzle, which starts as a drawing, like the one shown in Figure 1-1), wiring the components, and refining the results. You can also, quite literally, amaze your friends with the things you build. And if you go in for electronic gizmos that you can race, scare people with, or use to entertain crowds at parties, you can share the fun with others.



Don't forget the social aspect: Electronics projects devotees comprise a friendly bunch of folks who like to help each other. You can get into discussion groups online or join a local electronics club and find both interesting ideas and friendships at the same time. Chapter 16 provides ten great Web sites about electronics where you'll find such online groups.

Figure 1-1:
The schematic for the Dance to the Music project in Chapter 5.

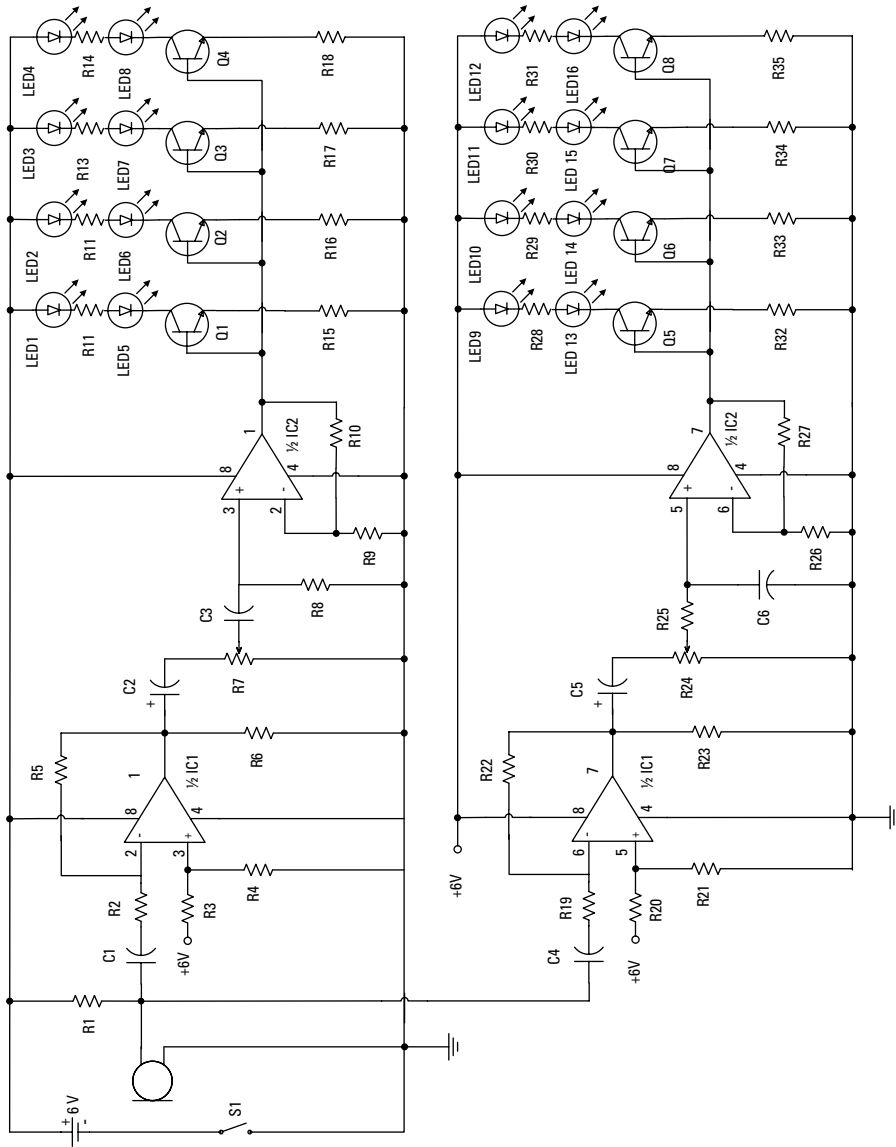

Building things you can actually use

So why, when you can buy an AM radio for \$7.95, would you decide to build one yourself with parts that cost \$30? That's a good question. The truth is just about everything you build in the projects included in this book — and most of the circuits floating around on the Internet — is something that you could probably buy in some form somewhere. But where would the challenge be in that?

Here's why hundreds of thousands of electronics junkies build instead of buying: Because they can. They can make something that grabs music out of the airwaves or sets off a light display or sends a little cart wheeling around the room themselves. We guess this is why people knit sweaters instead of buying them or work on old cars instead of taking them to mechanics. It just feels good to master something on your own.



Parts II, III, and IV of this book are where you can find all these cool projects, divided into categories by what the projects do, such as producing light, sound, or motion.

Some of the things that you build in this book are just for fun, like the dancing dolphin light display (Chapter 10). Other things have a practical use: the Couch Pet-ato (Chapter 14) keeps your cat off the furniture when you leave the house, for example.

Besides building gadgets that have a use, in some cases, you can build items more cheaply than you can buy them in the store. You could just end up with projects you can put to work and save a few bucks in the process.

Picking up lots of cool stuff along the way

One of the great things about electronics is that it teaches you about all kinds of things you can use in your life. For example, you discover

- ✓ How electricity works and how to stay safe when working with it
- ✓ How to read an electronic circuit and build it on a breadboard like the one shown in Figure 1-2
- ✓ How to use a variety of tools to solder, build, and customize casings to hold your gadgets
- ✓ How to work with integrated circuits
- ✓ A bit about wiring (which can give you a head start when you decide to learn how to add an outlet to your kitchen someday)

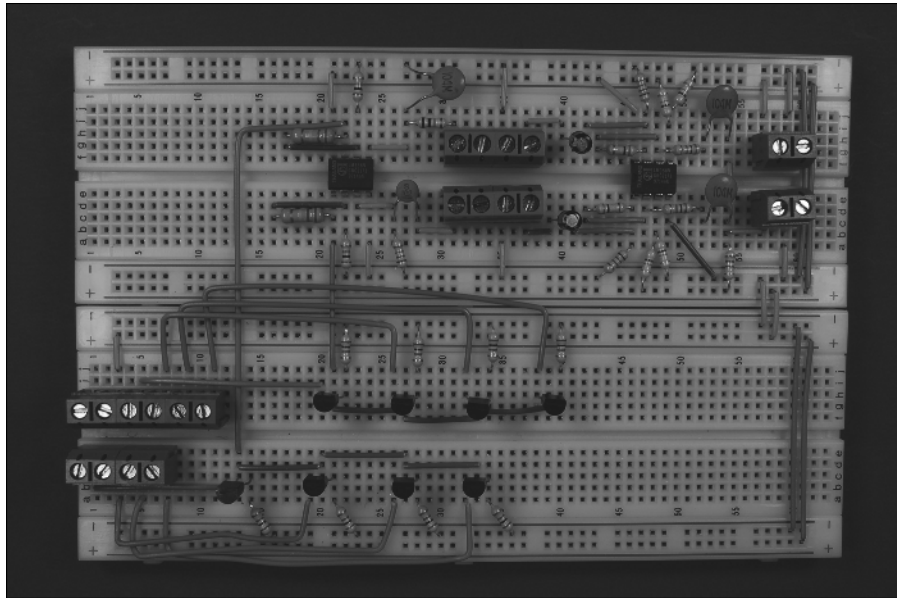

Figure 1-2:
Here's
what the
breadboard
for Dance to
the Music in
Chapter 5
looks like.



This book is full of lots of School of Hard Knocks information that might take you years to acquire doing electronics projects on your own; you'll also pick up lots of wisdom as you work through the projects and try things out for yourself.

What You Need to Get Started

Now that you're all excited about the benefits of working on electronics projects, you're probably wondering what this will cost you in dollars and workspace.

How much will it cost?

We tried to keep the cost of the projects in this book to under \$100; in many cases, the materials and parts will cost you under \$50 or so.

Depending on what you have lying around the house already, you might not have to invest in some of the basic tools, such as pliers or a screwdriver. You will probably have to spend \$50 or so for electronics-specific tools and materials such as a soldering iron, solder, and a multimeter like the one shown in Figure 1-3.



Figure 1-3:
A multi-
meter is a
measuring
device that
you'll use
often.

If you want to get really fancy, you could spend a couple hundred dollars on fancy testing equipment such as an oscilloscope, but you don't have to have that equipment to get through these projects, by any means.

Of course, in the world outside this book, projects can cost you hundreds of dollars. Like any hobby, you can spend a few bucks to dabble or mortgage your house to get into it in a big way. To get your feet wet in electronics, though, the investment is not that great.



Keep in mind that you can reuse some of the parts of one project (such as a breadboard) in another and cut your electronics budget further.

See Chapter 3 for information about the parts and tools that we recommend you get to build your basic electronics workshop.

Space . . . the final frontier

One thing you do need to leap into the world of electronics projects is space. That doesn't mean you have to take over your living room and build a fancy workbench. In most cases, a corner of your garage or laundry room stocked

with a shelf where you can keep parts and a card table works just fine. We do advise that you find a specific space for your projects.



In short order, your workspace will be filled with tools and parts and all kinds of (useful) junk (see Figure 1-4). See Chapter 2 for advice about safety when working with all this stuff. For example, stock your workspace with safety glasses that protect you whenever bits of wire go flying, and find a place where you can keep your soldering iron in a stand so it doesn't roll into your lap.

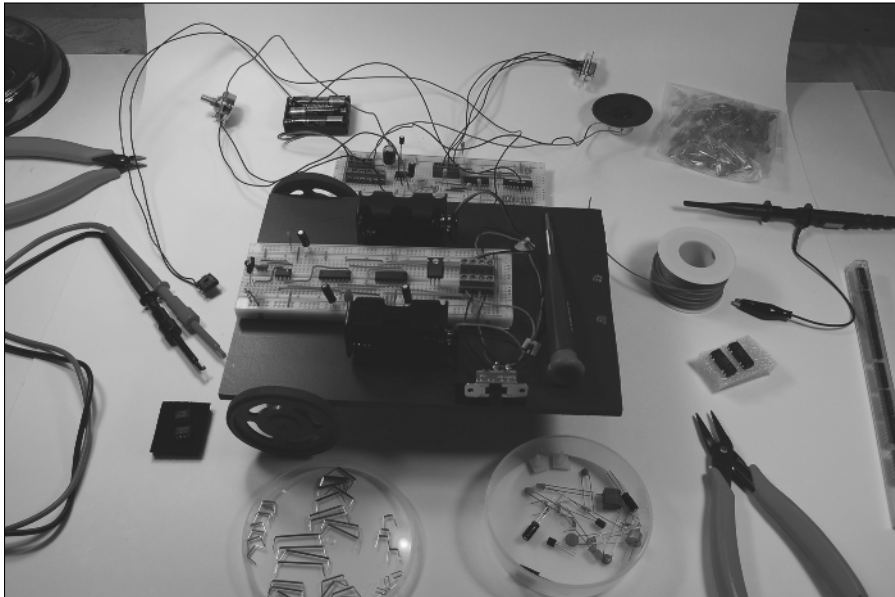

Figure 1-4:
A typical
assortment
of electron-
ics para-
phernalia.

We also recommend finding a spot that you can close off if there are others in your household — especially small children or pets — who could topple your work surface or eat tiny electrical parts and do themselves damage. Electronic projects don't happen in a day, and you might work on a single project over a matter of weeks. If you have a small room with a door to keep others out, great. If not, use your common sense about what you leave out on your work surface overnight.

