

# CHAPTER 1

---

## DIRECT-CHILL CASTING: HISTORICAL AND INDUSTRIAL PERSPECTIVE

---

### 1.1 INDUSTRIAL PERSPECTIVE

Aluminium is the second most economically important metal after steel, and of the approximately 80 million tonnes of aluminium cast every year, we estimate more than half is direct-chill (DC) cast on hundreds of DC casting machines worldwide, representing a multibillion dollar activity.

DC casting is also applied to copper, zinc, and magnesium alloys. The tonnage of products made by DC casting of these alloys is much smaller than aluminium and in the case of magnesium is estimated at less than 20,000 tonnes per annum (tpa), which is nevertheless critical to producing important wrought alloy products such as armour plate and sacrificial anodes.

Despite the economic importance of DC casting, and although there have been a number of reviews [1–5], including Eskin's recent book on physical metallurgy of DC casting [6], there exists no book in English giving a comprehensive coverage of the science and technology of DC casting. Two Russian monographs published in the former Soviet Union (V.I. Dobotkin, *Direct Chill Casting and Casting Properties of Alloys*, 1948, and V.I. Livanov et al., *Direct Chill Casting of Aluminium Alloys*, 1977) are significant yet outdated resources.

The two light metals, aluminium and magnesium, fit naturally together in a book on DC casting technology.

---

*Direct-Chill Casting of Light Alloys: Science and Technology*, First Edition.

John F. Grandfield, Dmitry G. Eskin, and Ian F. Bainbridge.

© 2013 The Minerals, Metals & Materials Society. Published 2013 by John Wiley & Sons, Inc.

DC castings are produced from either smelter primary metal or secondary scrap materials to make intermediate products for either remelting or forming (forging, rolling, and extrusion). The quality of DC castings has a direct bearing on the yield, productivity, and properties of the final products used in transport, buildings, and many other applications. Operators of DC casting installations therefore seek to control the quality of the castings, while minimising costs, maximising throughput, at the same time producing these products safely and with minimal environmental impact. This book is a resource to assist in achieving those goals.

Aluminium DC casting technology is now relatively standardised and is openly practised around the world; however, magnesium DC casting practice varies considerably from plant to plant, and the technology tends to be rather guarded. With tens of millions of tonnes of aluminium DC cast every year, typical capacities for aluminium vertical DC units are around 100,000 tpa. New installations are generally highly automated. Since the volume of magnesium DC cast is much smaller (<20,000 tpa), the DC casting units are on a much smaller scale to aluminium. The “boutique” scale, almost hand craft activity has precluded extensive investment in large-scale magnesium DC casting technology and development. While aluminium DC casting has continuously evolved as described later in this chapter, the DC casting practice applied to magnesium in many cases is exactly as was used in the 1940s, although there are some laboratory units with advanced capabilities.

The production of primary magnesium in the Americas and Europe has declined, while China has become the main primary producer. Consequently, the tonnage of magnesium that is DC cast has significantly reduced because Western primary producers were in the habit of DC casting large format T-bar remelt ingot, while Chinese smelters generally produce small remelt ingots cast in shape moulds. In the late 1990s, about 45,000 tonnes of magnesium was being DC cast [7], much of it remelt product; however, today, there is likely to be less than 20,000 tpa DC cast. Magnesium DC casting facilities in the West which have been closed include those of DOW, Hydro, and Timminco. US Magnesium, Dead Sea Magnesium, and AVISMA in Russia continue to produce magnesium T-bar remelt DC product. Meanwhile, Chinese DC casting of magnesium is increasing, and there is much interest in new magnesium wrought alloys and markets.

## 1.2 HISTORICAL DEVELOPMENT

Ingots of metal have been produced in shape casting moulds since antiquity. More recently in the twentieth century, ingots from aluminium and magnesium for subsequent deformation were also produced commercially by casting in permanent moulds. Although the demand for wide sheets and large extrusions was increasing since the 1920s due to the development of all-metal aircrafts, as late as in the 1930s and in some aluminium-producing companies up

to the 1950s, aluminium flat-shaped ingots and large, round billets were cast in permanent moulds that for the benefit of the quality and soundness were designed as tipping moulds, water-dipped moulds, or moulds with walls built up while pouring progressed. The desire to make the casting process of light alloys continuous was strong and resulted eventually in the development of DC casting.

The idea of making the casting process more productive through continuity can be attributed to J. Laing (USA) who in 1843 patented and successfully tested a machine for horizontal continuous casting of tubes and sheets from low-melting metallic alloys [8]. In this invention Laing proposed feeding the liquid metal from a vertical reservoir through a trough to a preheated horizontal mould with an inserted mandrel that rotated around its axis to prevent sticking to the casting. The tube was cooled at the exit from the mould.

Further development of the idea of continuous casting is ascribed to Henry Bessemer (UK) who in 1857 suggested and patented a device that would be nowadays called a twin-roll caster [9]. In this device, liquid steel was poured between two water-cooled drums, and the resultant thin solid sheet was extracted through curved guide plates where the sheet was continuously cut to measure, and further extracted through spring-loaded rolls as shown in Figure 1.1. Although it has been successfully tested, the device has not been

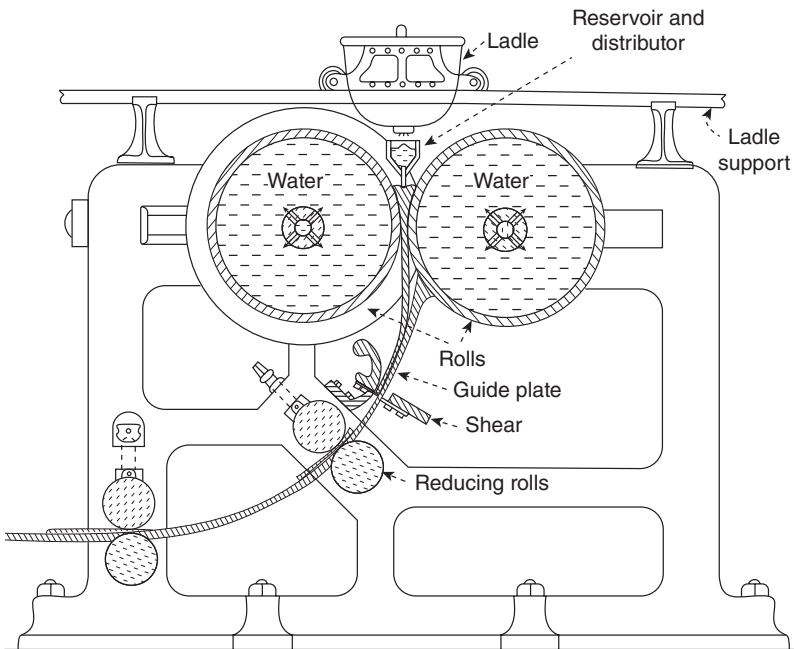

**Figure 1.1.** A scheme of Bessemer's continuous casting machine.

used in production. As Sir Bessemer rightly put in his speech delivered to the Autumn Meeting of the Iron and Steel institute in 1891, “. . . Some inventions, which appear worthy of trial, are never put to any practical test, through having appeared at a time when the state of the particular manufacture to which they apply was not so far advanced as to render the proposal feasible with the then existing state of knowledge, although at a later period, and a more advanced state of the arts, they would at once have been adopted” [10].

It took more than 100 years for the continuous casting of steel to become a mass production technology, but then with a different design, and more than that for the twin-roll casting to be applied to light alloys on the industrial scale.

The next step was made by B. Atha (USA) in 1886. He suggested casting molten steel into a high, water-cooled, bottomless mould and extracting the resultant billet with withdrawal rolls [11]. This method was used for semi-commercial production of steel bars  $100 \times 100$  mm in cross section in the beginning of the twentieth century, but did not make it to mass production.

A similar technique was developed by Siegfried Junghans (Germany) in the 1930s [12]. This machine was initially used at Wieland-Werke in Germany for casting brass [13]. The mould consisted of a copper tube open at both sides and surrounded by a water jacket. The melt was fed into the mould from the top, and the solidified part was withdrawn by rolls from the bottom. By a special system, the melt feeding was adjusted to the withdrawal speed in such a way that the melt level was maintained constant in the mould. This was important part of the technology and a vivid example that the continuous casting process offers an advantage of automation and control. The mould was lubricated and given an up-and-down oscillating movement to prevent sticking of the solid metal to the mould walls (the feature that was eventually adopted for the continuous casting of steel). Flying saws were positioned in the pit below the installation for continuous cutting of the billet into required lengths. Such a scheme had success and was widely used for casting copper and aluminium alloys in Germany, the USA, and the USSR. The Junghans process was applied to magnesium from 1937 onward [14] to cast 200-mm diameter extrusion billets and slabs up to  $600 \times 100$  mm.

Figure 1.2 depicts the Junghans method of continuous casting. Later on, Junghans added water spraying directly on the billet and made many innovations regarding the proper melt feeding and distribution system. Dobatkin [15] mentions that the maximum casting speed achieved for aluminium alloys with the Junghans machine was 300 mm/min for relatively small rods.

As compared with the permanent-mould casting used before, the Junghans method gave the following advantages [16]:

- truly continuous process with possibility of advanced automation that allowed increased productivity with less manpower;
- reproducible casting regimes that allowed reproducible quality of billets;
- better feeding of the central portions of billets with correspondingly increased soundness of billets;

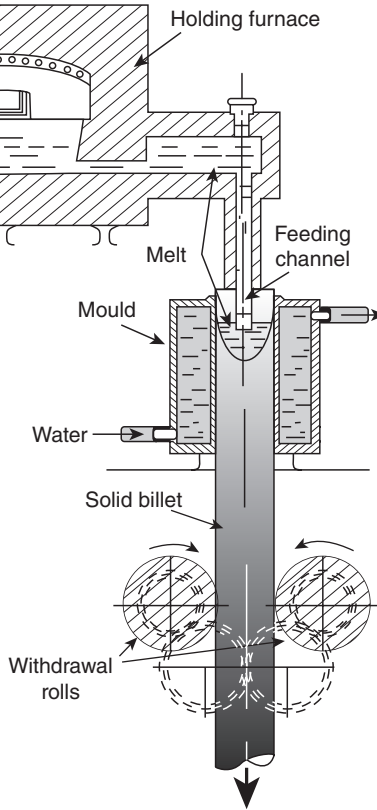

**Figure 1.2.** A diagram of Junghans' method of continuous casting. (Reproduced with kind permission of Taylor & Francis/CRC Press.)

- more uniform structure across the billet;
- better removal of gases during casting through the liquid portion of the billet;
- less scrapped material.

At the same time, this method did not solve all problems of permanent-mould casting, mainly due to the heat extraction being predominant through the walls of the mould [16]. As a result, the sump of the billet was deep, the solidified shell was subjected to high thermal gradients, and the air-gap formation required the maintenance of low casting speeds or, in other words, longer solidification times. Larger billets (300–500 mm in diameter) were characterised with inhomogeneous structure and chemical composition (macrosegregation). The long moulds that were necessary for proper cooling called for very fine finish of the internal surface.

In order to eliminate these shortcomings, it was necessary to develop a technology where the heat would be extracted predominantly through the solid part of the casting. As a result, the sump of the casting would be shallower and the solidification profile would be flatter. The macrosegregation, structure inhomogeneity, and radial stresses would be much less pronounced. These needs were met with a new casting technology developed almost simultaneously and independently in Germany and the USA. The technology was given a German name “Wasserguß” or “water-casting”, and was later called “direct-chill casting” or DC casting. As initially invented, the process is the vertical direct-chill casting or VDC, as opposed to horizontal direct-chill (HDC) invented subsequently. The priority here could not be established without reasonable doubt. What is known are names of the inventors and the companies where their inventions have been commercialised and used on an industrial scale. Berthold Zunckel (1935) [17], Walter Roth (1936) [18], and William T. Ennor (1938) [19] filed and subsequently received patents on the technology of casting that had the following common features. Melt was poured from the top in an open, relatively short water-cooled mould, which in the beginning was closed from the bottom by a dummy block connected with a hydraulic or mechanical lowering system. After the melt level in the mould reached a certain level, the ram was lowered and the solid part of the billet or the ingots was extracted downwards. The melt flow rate and the casting speed were adjusted in such a way that the melt level in the mould remained constant. As soon as the solid shell emerged from the bottom part of the mould, water was applied to the surface in a form of spray or water film. Cooling of the solid billet (or ingot) was further intensified by lowering it into a pit filled with water (which also made the process safer, as liquid metal, in the case of a bleed-out, was rapidly cooled in a large amount of water). The process was semi-continuous. As soon as the ram reached its lowest position in the pit, the casting was stopped, and the billet (or ingot) was removed from the pit. Figure 1.3a–c shows schematic drawings of these three inventions, obviously demonstrating that the principal similarities are more important than differences. The new casting technology gave flexibility in casting applications. Immediately, trials were started with round, rectangular, and hollow billets. In addition, multiple casting was possible with several moulds positioned on a single casting table.

The DC casting inventions were commercialised in Germany at Vereinigte Leichtmetall-Werke since 1936 [13] and in the USA at Alcoa since 1934 [20]. DC casting of magnesium soon followed aluminium in the 1940s at Alcoa in the USA [14], the Magnesium Elektron Ltd in the UK in 1944 [21], and at the Vereinigte Leichtmetall-Werke in Germany [22]. One can notice that the water cooling or direct chill in these first patents was done either by dipping the billet directly into the water bath or by spraying water onto the surface using separate sprinklers located along the billet length. But already in 1937, Roth suggested to use openings in the lower part of the water-cooled mould

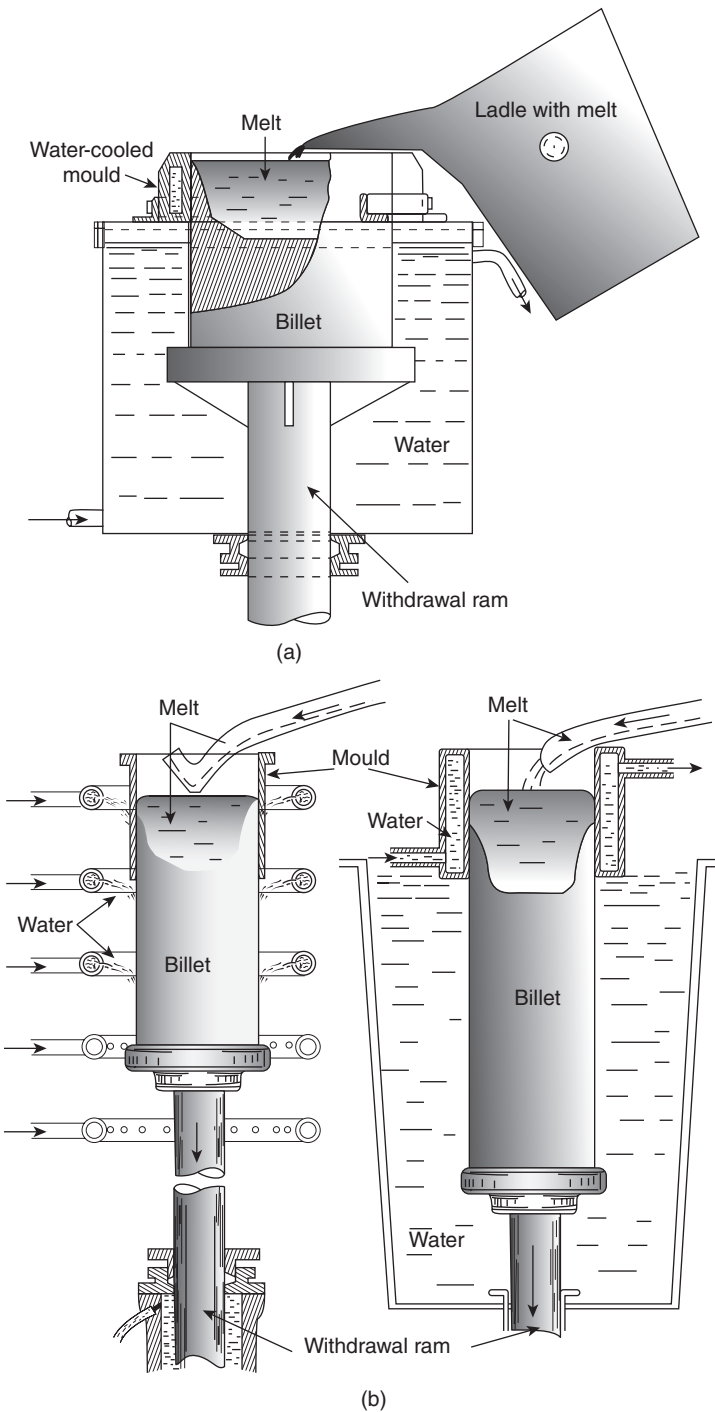

**Figure 1.3.** DC casting methods patented by Zunkel (a), Roth (b), and Ennor (c), and a scheme of a working DC casting machine used in the 1940s (d) [15]. (Reproduced with kind permission of Taylor & Francis/CRC Press.)

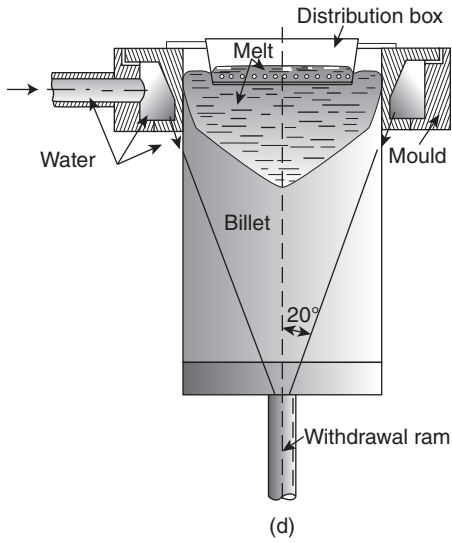
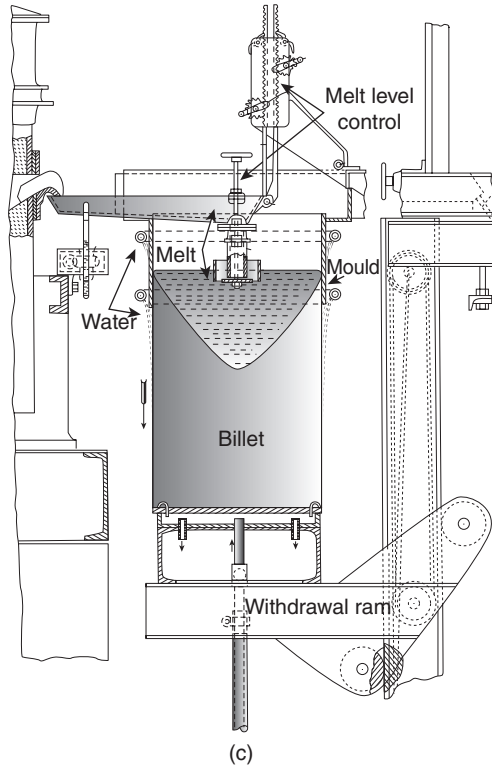

Figure 1.3. (Continued)

for spraying the coolant onto the billet surface [23]. Roth, Patterson, and Kondic were also among the first to publish scientific papers based on the extensive research of a new technology [24–28]. In 1939, the USSR started extensive works on the development and use of DC casting of aluminium alloys, building up mainly on the German inventions (Figure 1.3d) [15]. This rapid advance could be facilitated by tight economical links between the USSR and Germany, with many Russian and German engineers visiting each other, exchanging ideas and technologies. Well-known names in the Russian DC casting are S.M. Voronov, V.A. Livanov, R.I. Barbanel, and V.I. Dobatkin. Extensive reports on the Russian experience in DC casting as well as on the physical metallurgy of the process were published immediately after World War II [15, 16, 29]. Roth, Livanov, and Dobatkin recognised the important role of heat transfer, thermal contraction, and the dimensions of the semi-solid region in the billet, and made the first attempts to explain the formation of hot and cold cracks, macrosegregation, and the homogeneity of structure and properties distribution. We will consider these phenomena in Chapter 5.

DC casting of aluminium alloys was born and presents a vivid example of a technology that appeared just in time to serve the needs of the industry. The industry that demanded large blocks of aluminium for rolling and forging at this time was aircraft building.

In the period from 1924 to 1939, the average weight of an aluminium flat ingot cast in a permanent mould increased from 20 to 500 kg [30]. Most of bulk ingots and billets by the mid-1930s were made by permanent-mould casting, while the increased volume and cross section exponentially deteriorated the structure and properties of the cast metal. DC casting offered an answer to these demands, solving successfully and simultaneously two problems: control of solidification and production of large ingots and billets. In the 1950s, the weight of the DC cast ingot exceeded 3 tonnes and nowadays has reached 15–16 tonnes [31].

Let us here define the terms “billet” and “ingot” that are adopted in industry and in research literature. Billets are castings that are round in cross section and are mostly used for further extrusion. Large billets are also used for forging. Ingots are rectangular in cross section, with one side usually much longer than the other. Ingots are also called “slabs”, “blocks”, or “rolling ingot” and are for further rolling. In this case, the wider face of the ingot is called “rolling face”.

DC casting has a unique feature that makes it very distinct from previously used casting techniques. The solidification occurs in a narrow layer of the casting inside and below the mould. During the steady-state stage of casting, the shape and the dimensions of this region remains constant and reproducible from one heat to another. By controlling the melt distribution during feeding the mould, cooling conditions inside the mould, direct cooling below the mould, and the casting speed, the shape and dimensions of the solidification region can be maintained within the optimum limits. As these shape and dimensions determine the thermal gradient and are responsible for cracking,

macrosegregation, and structure homogeneity, the occurrence of these defects can also be controlled (see more in Chapters 5 and 6).

Extensive research performed in tight connection with industrial DC casting produced outstanding results. By the end of World War II all high-strength aluminium alloys in the USA and the USSR were cast by this new technique.

The comparison of DC casting and Junghans' method showed the following advantages of the former [16]:

- considerably reduced centreline segregation;
- increased density of the central portion of a billet;
- finer and more homogeneous structure with correspondingly improved mechanical properties;
- better surface quality;
- lower operation costs.

The first three features are attributed to the shallower sump and flatter solidification front. It was shown that for the same casting speed and billet diameter, the sump depth would be four times larger for the Junghans' method than upon DC casting [16]. Therefore, using the scaling rules, one can say that the billet with the same sump depth can be cast four times faster by DC casting than by Junghans' technique. The DC cast billet would also have four times higher solidification rate and hence better structure and properties [15].

The great and obvious success of DC casting triggered a torrent of inventions directed on the improvement of the technology. Some of these inventions were short-lived, some were minor. But some became very successful. A more detailed insight into the mould design and considerations will be given in Chapter 6. In this chapter, we will only briefly summarise some of the important milestones.

One of the important problems to be tackled was the melt level in the mould and the height of the mould itself. Initially, moulds were quite high to assure that the bottom of the sump will be confined within the mould. Later it was found that it was not necessary and that the thickness of the solid shell should just be sufficient to hold the liquid contents. However, the melt level inside the mould should have been maintained carefully in order to assure that on the one hand, the solid shell of required thickness is formed, and on the other hand, the extent of the solid shell within the mould is not too long to prevent the uncontrolled air-gap formation and too high a thermal gradient (Figure 1.4a, b). The necessity to maintain low melt level in the mould became more and more a notorious problem, as the cross sections of billet and ingots became larger and larger. But there was no way out – the level should be maintained low in order to avoid large thermal stresses, wide transition region, and large zone of air gap within the mould.



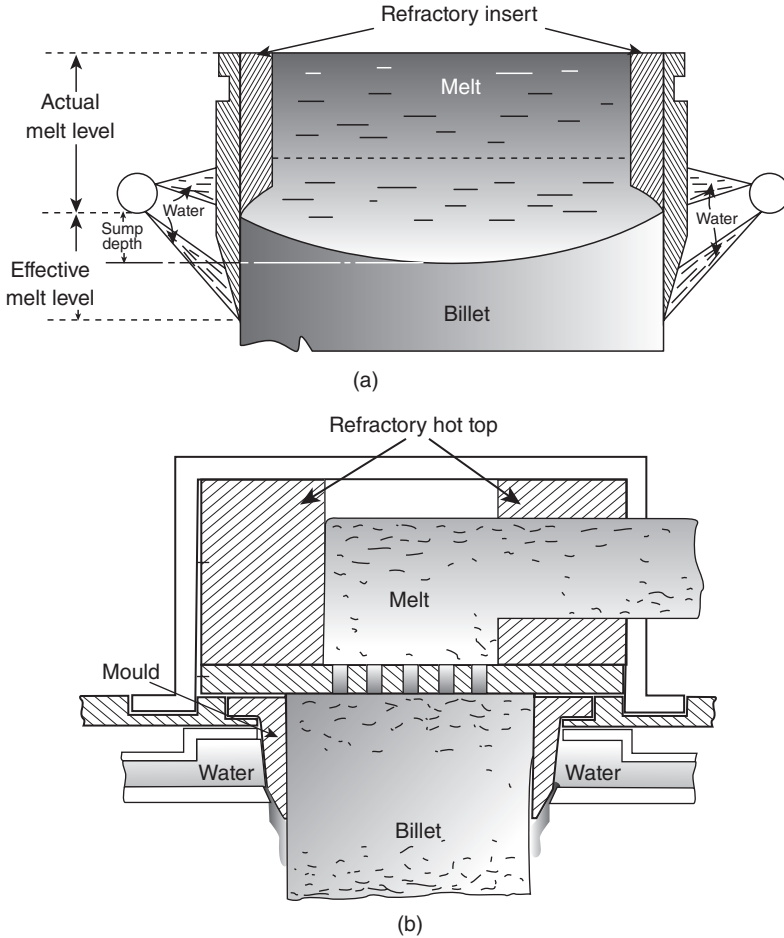

**Figure 1.5.** Development of DC casting moulds in the 1960s–1990s: (a) refractory insert; (b) hot top; (c) dual-jet mould; and (d) electromagnetic casting. (Reproduced with kind permission of Taylor & Francis/CRC Press.)

A.G. Furness and J.D. Harvey of British Aluminium in 1973 [34] (Figure 1.5b). The introduction of the hot-top mould was an important step that won much popularity and spread through casting houses around the world in the 1970s. Essentially, hot-top moulds are the main means of vertical casting of extrusion billets where the technology is also known as level-pour casting as the melt is fed to several moulds through the joint feeding system that includes the launder and hot tops with the same melt level. Because of the large deformations of the rectangular ingots at the start of casting where the short ends lift up (butt curl), it is not possible to have an overhanging refractory hot top else

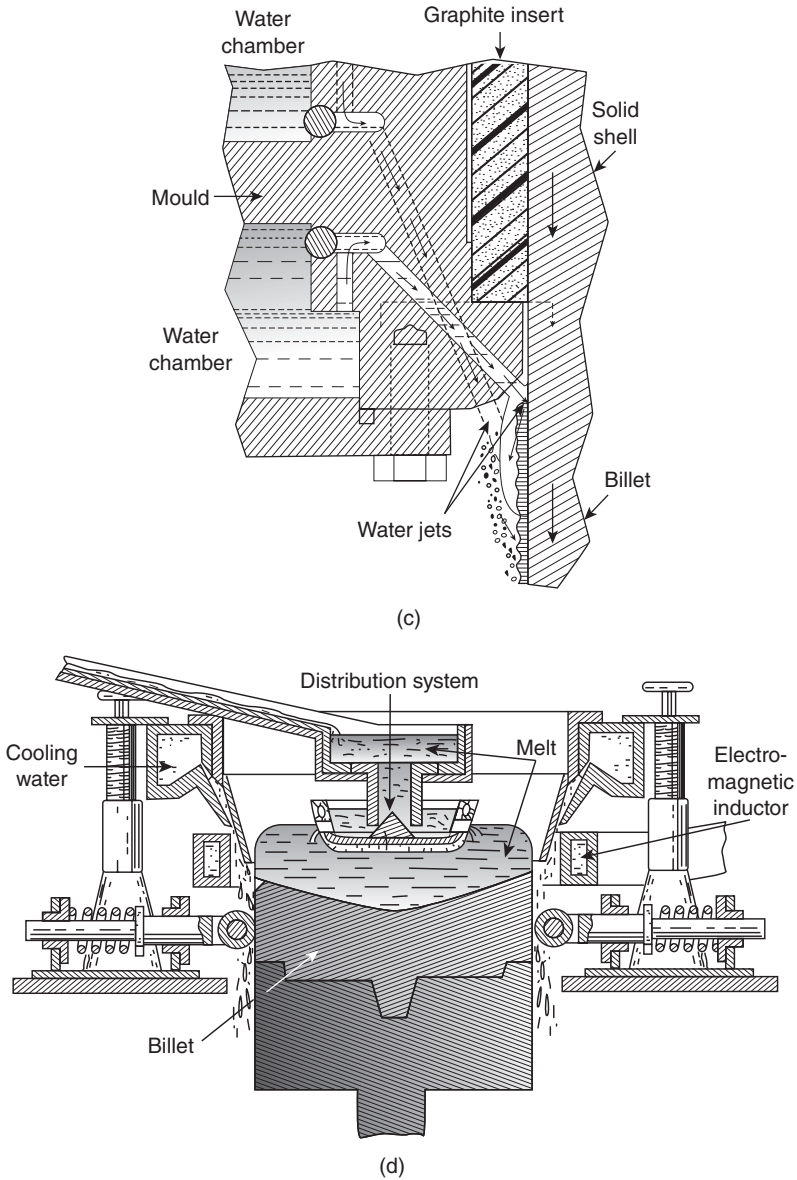

**Figure 1.5.** (Continued)

the ingot pushes up into the refractory and destroys it. Refractory paper-lined slab moulds are, however, used for some alloys.

The control of heat transfer in the mould and of the meniscus position below the hot top was substantially advanced by constant feeding of gas into the mould. This process was invented by Ryota Mitamura and Tadanao Itoh at Showa Denko in Japan (1977) [35]. The air and oil in the Showa design are

fed into the mould through channels beneath the refractory hot top. This mould technology was further developed by a number of companies (see Section 6.2). The most widely used version is that developed in 1983 by Wagstaff Engineering as the “AirSlip®” mould where the gas and lubricant are supplied to the inner surface of the mould through a fine-porous graphite ring [36]. The main improvement of these gas-pressurised moulds was in the surface quality and increased casting speed. Many other variants of these moulds with different arrangements for introducing the gas and lubricant followed. Examples of these include

1. VAW’s AirGlide moulds where the reduced amount of gas and oil was fed in the meniscus region through peripheral radial channels and a graphite insert was positioned below the outlets;
2. Hydro Aluminium’s Hycast moulds, also using a graphite ring but with the air delivered in the upper portion and the lubricant in the lower portion;
3. injection of the gas through porous refractory [37];
4. injection of gas and oil through a porous sintered bronze disk [38].

The next problem to be solved was the formation of the air gap, when the solidified shell contracts away from the mould, effectively decreasing the heat transfer. An area of a coarser structure was formed inside the casting at some distance from the surface because of the lower cooling rate at which the billet was solidified while travelling from the point of the air-gap formation to the point of water impingement below the mould. Moreover, the slowed-down cooling in this area might cause failure (even remelting) of the thin shell, resulting in bleed-out. The use of gas-pressurised moulds partially solved the problem, taking the initial point of contact against the mould (the base of the meniscus) down, into the influence of the water spray cooling that extends up into the mould. An elaborated attempt to overcome the air-gap problem and to control the cooling in the start-up stage of the casting was the invention of a so-called dual-jet mould by Wagstaff Engineering (1994) [39]. In this mould design, two water jets exited the mould and hit the billet surface at two different angles, 22° and 45°, as shown in Figure 1.5c. The region of slower cooling was thus considerably shortened. Wagstaff Engineering also produced a combination of air-slip and dual-jet moulds.

It is worth noting here that the whole system of establishing the correct mould length and balancing the cooling distance, air gap, mould wall heat flow, and meniscus size is under development and has yet to receive full confirmation in the industry. At the moment, the commercial technologies are using some of the elements of this system, sometimes on the intuitive level with empirical feedback. See more on the mould design in Chapter 6.

DC casting offers flexibility in mould design and in control of solidification conditions. So-called clad-ingot or composite-ingot casting is a good example of that. Although the idea is not new (first trials with aluminium were in 1972

[40]) and there have been a number of patents describing the casting of a layered ingot composed from different alloys [41], the industrial-scale technology has been developed only recently (2004) and is already commercialised by Novelis as “Fusion™” casting [42]. In this technology an open ended, water-cooled mould has a divider wall with a separate cooling system, dividing a feed end of the mould into at least two separate feed chambers. During casting, different alloys are fed through separated launders into different but adjacent chambers. A self-supporting surface is generated on the surface of the core alloy, and the second alloy gets in contact with the solid shell of the core alloy and solidifies, forming a continuous bond [43].

Another example of technology flexibility was the so-called electromagnetic casting or mould-less casting. It is obvious that the idea of DC casting included the mould with primary cooling of the melt where the solid shell was formed and the secondary, direct cooling of this shell with water outside the mould. The existence of the mould created some difficulties: premature solidification with potential hanging of the billet or ingot, freezing of liquid meniscus and formation of banded surface with cold shuts, formation of air gap and corresponding change of solidification conditions, requirements for lubrication, and so on. An engineer, Zinovy N. Getselev, who worked at Kuibyshev (Samara) Aluminium Works in the USSR in the late 1960s came up with an idea to abandon the mould altogether. The molten metal was shaped and held in the required position by an alternating electromagnetic field that induced electromotive forces and eddy currents in the melt. The interaction between these eddy currents with the external magnetic field created electrodynamic forces that compressed the melt and balanced the metallostatic head pressure, thus levitating the melt. The cooling water was applied onto the surface of this moulded melt, and the solidified part was withdrawn downwards as in normal DC casting [44, 45]. Start-up was, however, difficult and required very accurate maintenance of several parameters such as the pouring rate, water flow rate and composition, initial casting speed, and strength of the magnetic field. Figure 1.5d depicts the principle of the proposed method. The most important features of this method of casting are the absence of the air gap between zones of primary (mould) and secondary (submould) cooling typical of traditional DC casting, and stirring of the melt in the sump by electromagnetic forces. This technology and its variations were patented in most industrialised countries between 1969 and 1977. The advantages of electromagnetic casting (EMC) include very good surface that requires almost no scalping, less macrosegregation due to the melt stirring during casting, and more uniform and generally finer structure [46]. The sump during electromagnetic casting is shallower, and the thermal gradients are less (Figure 1.4c). The disadvantage of this method that limits its wider application is the relative complexity and high capital cost of the casting machine. Technology royalties were also a barrier to the adoption of the technology.

The VDC that we have talked about is not a true continuous casting process as the length of the billet or ingot is limited by the depth of the pit and is

usually between 4 and 10 m. Fully continuous VDC casting can be achieved with rolls supporting the product and a flying saw below the mould cutting the ingots to the desired length. DOW pioneered this approach for magnesium casting at Madison, Illinois (USA). This process was used for aluminium but not so nowadays, though it continues to be used for magnesium and copper today.

For aluminium and, potentially, magnesium, another casting scheme seems to be more promising: horizontal, or with the bend so that the strand coming out of the vertical mould is bent to the horizontal position (as it happens in the continuous casting of steel). Actually, the first inventions of Laing and Bessemer were horizontal continuous casting set-ups. HDC casting with a flying saw was developed in France and in the USA during the 1960s [41] and was subsequently adopted for small aluminium alloy remelt ingot, small-diameter forging stock, rolling slab,  $10 \times 1000$ -mm strip, T-bar, and extrusion billet production. Attempts to apply HDC casting to magnesium include efforts of DOW, Hydro, and AMC, but these have been fraught with technical difficulties [47]. As yet, HDC casting has not been commercially applied to magnesium but continues to be investigated [48].

The scheme of the HDC process is shown in Figure 1.6a (a version used for Mg casting at CSIRO, Brisbane). Within this technological approach, long billet and ingots can be cast without interruption. Flying saws or shear cutters can be used to cut the ingot to measure. Continuous operation allows for more complete automation and better control of the casting parameters. In addition, there is no need for expensive deep casting pits and hydraulic rams, and so on. This technological scheme also can use an analogue of hot top. In this case, the insulating partition is inserted between the pouring reservoir and the mould. This partition has two roles. First, it provides the control of the melt flow, and second, it seals the set-up against melt leakage.

Because the casting axis is at right angles to gravity in HDC casting, the natural convection driven flows in the melt are not symmetrical about the casting axis as they are in VDC casting. To offset this effect, the mould inlet is positioned in the lower half of the mould. We discuss this issue in more detail in Chapter 6.

HDC casters are generally run at higher casting speeds than VDC casters. However, despite being fully continuous, the lower number of strands cast at any one time results in a lower annual capacity than VDC casting. Typical capacities are around 20,000–40,000 tpa for an HDC caster (depending on the product size and number of strands), whereas a modern VDC caster capacity is around 100,000 tpa. On the positive side, the capital cost per tonne of an HDC unit is less. See Table 9.2 in Chapter 9 for economical comparison between VDC and HDC.

Other schemes of continuous casting are used for more specific products, most notably for thin sheets and rods. Let us consider them briefly.

Wire is difficult to produce from DC castings and alternate processes must be used. During World War II, aluminium wire for fasteners was mass

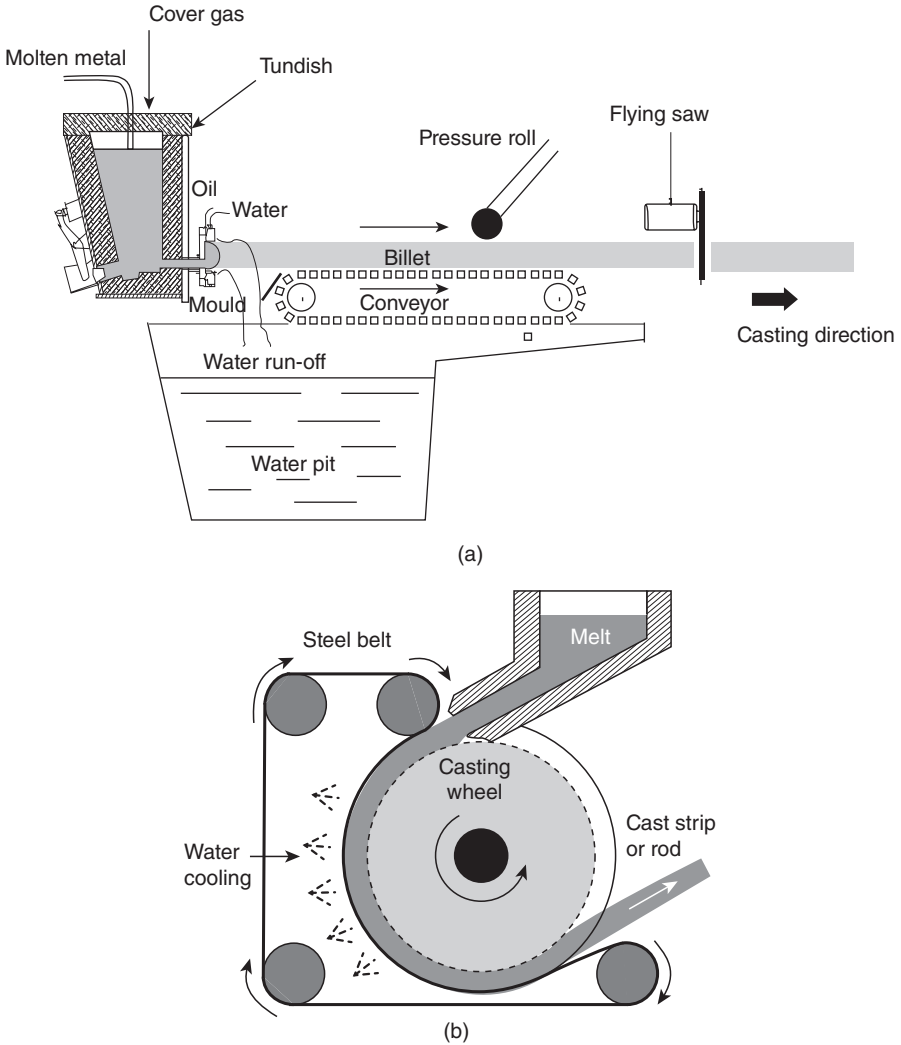

**Figure 1.6.** Continuous casting methods: (a) horizontal direct-chill casting; (b) Properzi wheel and band casting; (c) Hazelett twin-band casting; and (d) twin-roll casting.

produced in the USSR by the method of horizontal continuous mould-less casting suggested by V.G. Golovkin. In this method, the aluminium melt was squeezed by metallostatic pressure from the holding furnace through a side, calibrated opening. The round-shaped exudate was immediately sprayed with water and withdrawn by rolls in the horizontal direction and then coiled. Wire up to 9 mm in diameter was produced at a speed of up to 36 m/h [49].

One of quite popular schemes for production of thin rods and wires is the Properzi casting machine developed by Ilario Properzi of S.p.A. Continuous of

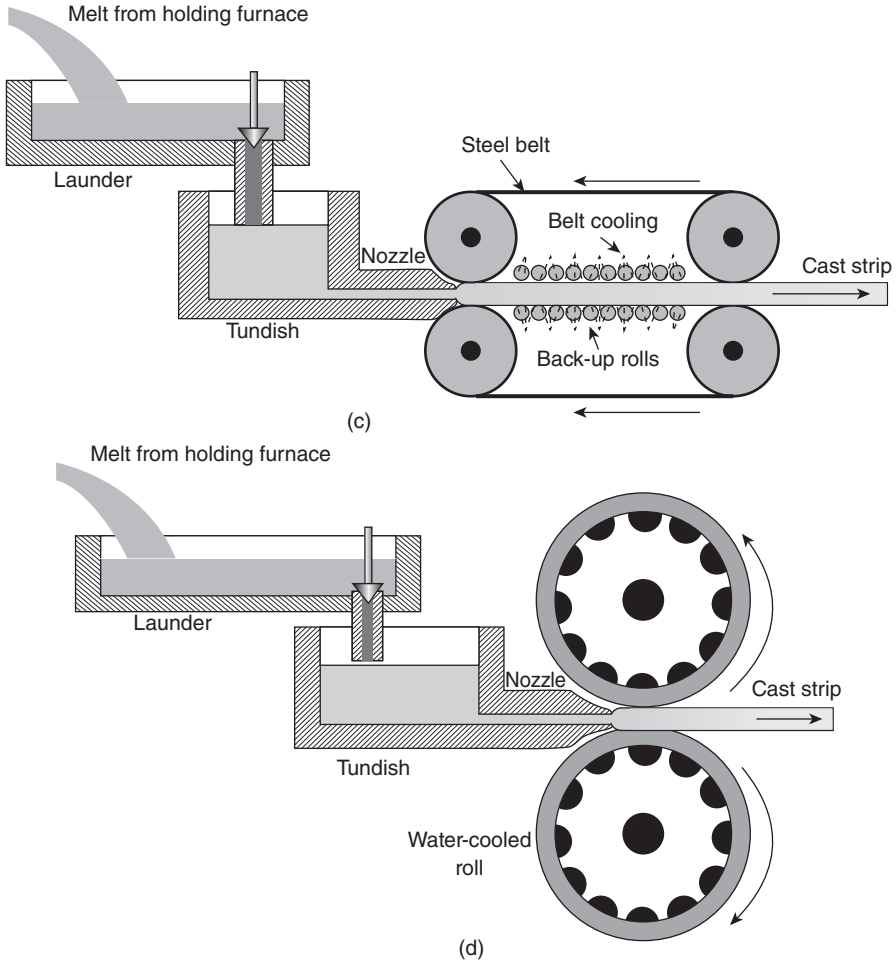

**Figure 1.6.** (Continued)

Milan in the late 1940s [41, 50, 51]. The precursors of the Properzi technology were strip and slab casting machines invented by Lyman (1882) and Daniels (1886) [50]. Since the 1950s, this method became standard for casting copper and aluminium electric conductor wire. The casting scheme is wheel-and-belt, where the melt is poured in the opening between the rotating copper wheel with the groove of the rod/wire shape and the steel band wrapped over the periphery of the wheel, which is water-sprayed from the outside (Figure 1.6b). The wheel can be also water-cooled. The solidified rod/wire is extracted continuously and coiled. In this setting, the mould is virtually moving with the casting, avoiding friction problems. The technology is used mostly for pure or

low-alloyed metals. Nowadays, 85% of aluminium wire is produced by Properzi-type technology.

More recently, the Properzi continuous casting method became useful for production of master alloy rods such as AlTiB and AlTiC, where the casting step was followed by Conform or other extrusion stage. There is a modification of the Properzi method for casting narrow sheets; it is called the Rigamonti method. It is used for producing strips up to  $500 \times 20$  mm in cross section that are then stamped to make aerosol containers, cans, and tubes [52].

The Hazelett twin-belt caster is a representative of a family of continuous casting machines for production of thin sheets and strips which are an alternative to DC casting slabs and rolling them. Clarence W. Hazelett has suggested a series of designs between 1948 and 1956 [53]. The main principle is that a metallic sheet is solidified between two wide, continuously moving steel bands that are water-cooled from inside (Figure 1.6c). The bands are made of steel. An alternate configuration developed by Alusuisse used articulated copper blocks. The edges of the sheet are formed by dams at the edges of the bands. Sheets up to 2000 mm wide can be produced continuously. At the beginning, the choice of alloys was limited to low-alloyed aluminium. Later with the development of better feeding and cooling control (especially though use of helium), the casting of medium-strength alloys became possible as well. Generally, the material coming from a Hazelett caster is too thick to coil, and the most useful configuration is best achieved when the sheet passes through a hot-rolling mill immediately after casting.

The idea of Bessemer to use a combination of a casting machine and a rolling mill to produce a strip or sheet was quite fruitful and resulted in a number of successful attempts to introduce this technology into industrial practice [54, 55]. The machine of Hunter (1957) eventually became a prototype for modern twin-rolled casters. The principal innovation was the withdrawal of the solidifying sheet upwards from the liquid pool instead of downward [9] or sideward [54]. The basic incentive for the development of the twin-roll casting was minimising the need for further rolling. The cast strip first rises vertically upward from the rolls and is then bent in a smooth curve to pass in a horizontal direction into the straightener and eventually to the coiler. The main challenge is to maintain the balance between metal throughput, speed of rolls, and the efficiency of heat removal. This problem was solved by the design of a special melt distributor that narrows the incoming melt stream almost to the size of the “roll bite” and helps to reduce the solidification time. The melt temperature should be maintained close to the liquidus. The maximum thickness of aluminium strip produced by the original Hunter twin-roll caster was limited to 6.5 mm [50]. In the late 1970s, Hunter introduced a much more robust machine (“SuperCaster”) which offered an increase in productivity and was capable of casting a wider range of alloys at sheet widths up to 2.0 m. Twin-roll casting is nowadays the main means to produce continuously cast thin sheets from aluminium alloys, which can then be cold-rolled to thinner sheets or foil [31].

The upward melt feeding of the original Hunter design is currently replaced by horizontal feeding, especially for the production of wide aluminium sheets 1000–2000 mm wide and with the thickness down to 2 mm (Figure 1.6d). Aluisse and Pechiney made such machines. The casting speed usually depends on the alloy, between 1 and 5 m/min. These casters are most suitable for alloys with a narrow solidification range, for example 1000, 3000, and 5000 series (with up to 2.5% Mg content). When casting more concentrated alloys, the casting rate must be significantly reduced, leading to an uneconomic productivity [52]. Modern twin-roll casters, known as Jumbo 3C, are capable of casting wide sheets more than 2000 mm wide and down to 2 mm thick. Such casters give an advantage of rapid solidification – less than 3 seconds for a strip of 10-mm thickness [52]. To use the full benefit of this advantage, the shape and size of the nozzle are designed to ensure a regular, turbulence-free molten metal supply. A modern twin-roll caster features a tilting melting/holding furnace; a molten metal feed system including a motorised support table, a tundish, and a preset-up nozzle kit; and an automatic level control system in the tundish and nozzle.

The cooling rates in a twin-roll caster are significantly higher than those of DC casting,  $10^2$ – $10^3$  K/s versus 1–10 K/s, which are beneficial for the resultant microstructure and extend the solubility limit of some alloying elements. On the other hand, the deformation of semi-solid material and high thermal gradients cause problems with macrosegregation and oriented grain growth. The primary markets for continuously cast sheet are construction, household foil, and can stock. The advantages for the flat-product industry include elimination of the DC casting stage, scalping, breakdown rolling, and general lowering of capital costs. Its application to magnesium alloys is also promising [56]. Starting from the early 1980s (Dow Chemical), the technology of twin-roll casting of magnesium is going from R&D to pilot and semi-commercial scale, and full-scale production seems likely soon. Recently, several Mg twin-roll caster research programmes have been under development in different countries (Posco, Korea; GKSS-HZG, Germany; CSIRO, Australia; and Canmet, Canada). The developments have resulted in the successful production of full-size 1.5-m wide coils of magnesium sheet in 2009 [57] and 2-m wide sheets in 2011 [58].

Continuous casting offers obvious advantages as compared to semi-continuous DC casting followed by deformation [52]. The processing costs are only a third to a half as high, operating and investment costs are only a quarter to a third as high, and there are smaller space and labour requirements. Less energy is required because it is no longer necessary to preheat the ingot before hot rolling. The productivity is 15–20% higher; the material consumption is 1.5–2% lower. Some typical characteristics of the different techniques of continuous casting are shown in Table 1.1. Obviously, the DC casting does not have an alternative when it comes to producing large-scale billets and ingots for subsequent deformation from all kind of alloys. The methods of continuous casting are more specialised and limited to low- and medium-strength alloys.

**TABLE 1.1. Typical Features of Different (Semi-)Continuous Casting Processes**

Process	Cooling Rate (K/s)	Casting Speed (mm/min)	Product	Dimensions of Casting	Alloy Selection
Direct-chill casting	0.5–20	Up to 200	Round and hollow billets, flat ingots	Max. diameter 1200 mm, max cross-section 2400 × 1000 mm, length 4000–10,000 mm	All alloys
Properzi	0.5–15	22,000	Rod and wire of different cross-section geometry	Max cross-section 5000 mm <sup>2</sup> , typical 12 mm diameter	Al, Al–Mn, Al–Mg–Si, Al–Ti–B, Al–Fe, Al–Zr, Al–Cu–Mg
Rigamonti	–	Up to 14,000	Sheet	Thickness 20 mm; width 500 mm	Al, Al–Mn; Al–Mg (less than 4.5% Mg), Al–Mg–Si, some Al–Cu–Mg
Hazelett	Up to 100	Up to 9000	Strip and sheet	Thickness 15–25 mm; max width 2000 mm	Al, Al–Mn, Al–Mg
Twin-roll casting	200–1000	Up to 38,000	Sheet, strip, foil	Thickness 0.635–10 mm, width 600–2,134	Al, Al–Mn, Al–Mg

Yet another alternative to DC casting for remelt ingot production is the recently developed track and belt system of Properzi. Articulated, copper blocks circulate on a track with the liquid metal being fed at one end, a water-cooled belt applied on the top, and the bar withdrawn at the other end [59].

Two more methods of continuous casting should be mentioned, though they are not very common. The first is the Ohno continuous casting which is used for unidirectional solidification of copper, silver, bismuth, aluminium, and other alloys. The listed benefits are clean surface, near-net shape casting configuration, lesser porosity, and in some cases, single-crystalline casting [60]. The concept is quite original and has been suggested by Atsumi Ohno in the 1970s and formalised later in his paper [61]. The mould is heated to a temperature above the liquidus of the cast alloy in order to prevent solidification on mould walls. The melt is cooled directly at the exit from the mould, and the semi-solid material is withdrawn from the mould to the cooling area where water is sprayed on the surface of the billet (Figure 1.7a). The zone of mould cooling where the shell is formed in the DC casting is therefore absent in the Ohno process. Inside the mould, the heat is extracted along the axis of the billet rather than in the transversal direction as in the conventional continuous or DC casting. Rods and wires of small cross sections (up to 2 mm) can be produced in vertical or horizontal arrangement [62].

The other interesting modification of DC casting is upward casting. This casting scheme has an obvious advantage of protection of the melt in the mould from atmosphere. Several schemes have been suggested with the following common features [41]: melt is supplied directly from the furnace or holding furnace through a closed trough that is attached to the water-cooled mould; a substrate or dummy is placed at the top of the mould and solidification starts onto this substrate; the melt is supplied to the mould at a constant rate through either metallostatic pressure from the furnace that is elevated above the mould level or by applying external pressure onto the melt surface in the furnace (Figure 1.7b). Secondary water cooling poses a challenge and needs to be designed with wipers or special rings that prevent water from falling back into the mould [63]. Some casting schemes do not have secondary cooling at all. This approach is used for production of copper rod. The advantages of the upward casting include well-organised melt feeding which requires no melt level control and prevents leakage of melt upon bleed-out; easily achieved melt protection through use of closed melt delivery system with protective atmosphere; and simple security automation by using melt detection sensor at the exit from the mould [63, 64]. All these features make the upward casting particularly interesting for casting magnesium alloys.

Let us now compare the casting of aluminium and magnesium alloys. The production of both materials uses basically the same technologies yet with some peculiarities dictated by the properties of the base metals.

Although the commercial application of magnesium alloys dates back to the beginning of the twentieth century, the production level of magnesium is much smaller than that of aluminium (less than 0.7 Mt of Mg vs more than

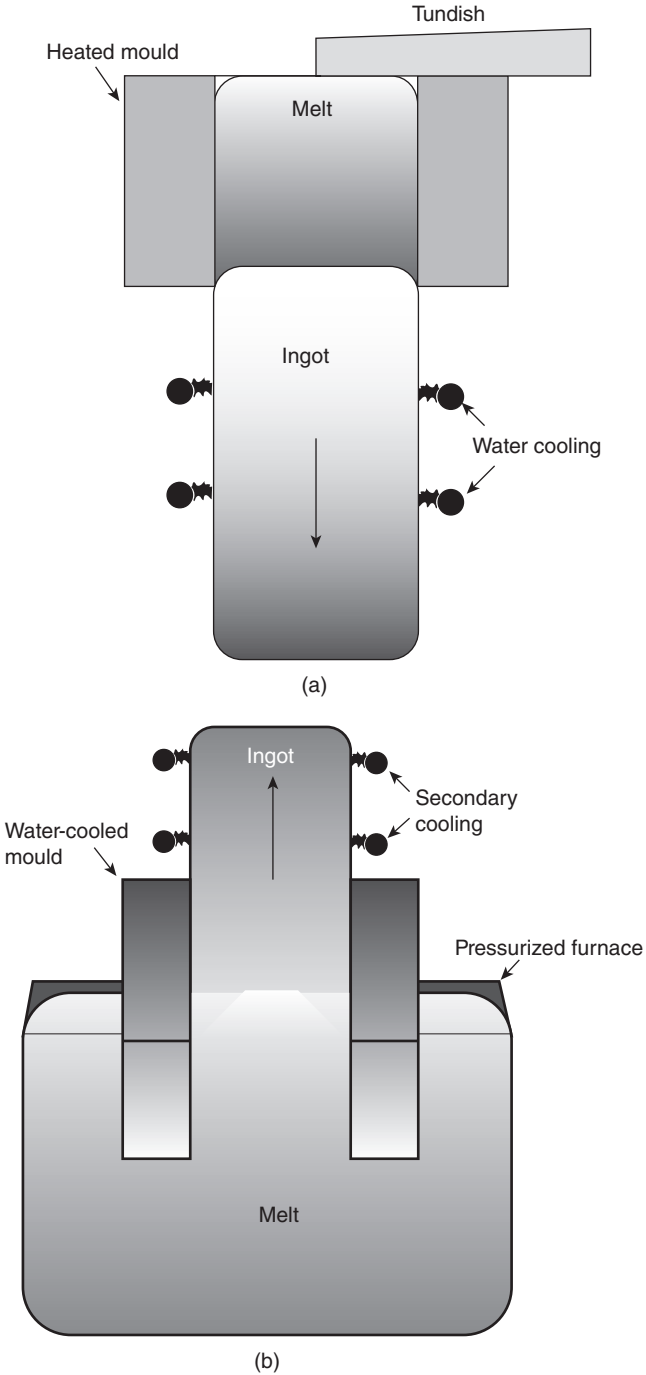

**Figure 1.7.** Ohno continuous casting with heated mould (a) and upward direct-chill casting (b).

25 Mt of Al in 2010 [65]). On top of that, the total amount of aluminium in use is much larger; due to its excellent recyclability, most of aluminium produced since the beginning of production in 1886 is still in use, which amounts to 640 Mt [66]. Also the commercial demand for magnesium alloys is much smaller. Most of magnesium cast products are currently produced by die casting. DC casting has been applied to magnesium alloys since its invention. A very important contribution of these earlier works was the possibility to use water as a coolant agent [49]. But the natural fear of potential explosion upon direct contact of magnesium with water resulted in the prolonged use of ingot casting in a submerged mould. From the 1960s, the vertical DC casting is used on an industrial scale for production of billets and ingots. Today, hot-top and gas-pressurised AirSlip-type moulds are most frequently used, though horizontal DC casting and twin-roll casting are being rapidly developed.

It is a common notion that magnesium alloys freeze faster than aluminium alloys due to their lower volumetric specific and latent heats. This causes difficulties when using hot-top moulds due to freezing of metal against the refractory hot top. Also magnesium alloys frequently have a larger solidification range which makes them more prone to segregation, cracking, and other casting defects. Table 1.2 lists some of the thermo-physical properties of these two base metals as well as the possible consequences for their solidification behaviour and casting performance.

In summary, magnesium alloys exhibit faster primary solidification, but overall longer solidification path with potentially high thermal gradients. Oxide film that plays an important role in holding together the liquid bath in the upper part of the mould is very weak in magnesium alloys, which may trigger bleed-outs, surface cracking, and liquation during casting [49]. And, finally, magnesium and its alloys are highly reactive with oxygen and nitrogen, which requires special protection of the molten magnesium that can combust in air, as well as special safety precautions upon casting in order to prevent reaction of molten magnesium with cooling water generating hydrogen, for example, in the case of bleed-out.

This last but not the least difference with aluminium determines some specific casting schemes that include melting under flux, use of silica-free refractories, closed transport of melt into the mould (e.g. using siphon, mechanical, or magnetohydrodynamic pumps), blowing of protective gas mixture (e.g. SF<sub>6</sub> and CO<sub>2</sub>) onto the surface of the melt, and special means to prevent interaction of molten magnesium with cooling water (e.g. using special vacuum-suction systems).

All these issues are addressed in Chapters 2, 3, 5, and 6.

The history of DC casting invention and progress shows that the engineering ingenuity always matched the demands of the industry and answered the challenge of new products and new materials. Today all aluminium alloys for deformation (wrought alloys) are produced by DC and continuous casting techniques and supply vital industries such as aerospace, automotive,

**TABLE 1.2. Thermo-Physical Properties of Al and Mg [67–70]**

Property	Al	Mg	Consequences for Mg as Compared to Al
Thermal conductivity at 300°C, W/m K	233	150	Large thermal gradient in a casting, slower heat removal, but per unit volume heat removal rate is comparable
Specific heat of solid at 300°C, J/K kg	1029	1151	
Volumetric specific heat of solid at 300°C, J/K m <sup>3</sup>	$2.72 \times 10^6$	$1.93 \times 10^6$	Easier to cool the same volume
Specific heat of liquid, J/K kg	1300	1357	
Volumetric specific heat of liquid, J/K m <sup>3</sup>	$3.08 \times 10^6$	$2.14 \times 10^6$	Easier to cool the same volume
Solidification range of some alloys, K	3004–25 5052–43 6061–70 2024–138 7075–140	AZ31–25 ZK60–117 ZC71–180 AZ80–183 AZ61–202	Larger solidification range makes alloys more prone to casting defects
Coefficient of linear thermal expansion, K <sup>-1</sup>	$23\text{--}24 \times 10^{-6}$	$26 \times 10^{-6}$	More prone to air-gap formation, shape distortion
Thermal conductivity of liquid, W/m K	91	79	Slower superheat dissipation
Latent heat, J/kg	$397 \times 10^3$	$368 \times 10^3$	
Volumetric latent heat, J/m <sup>3</sup>	$9.4 \times 10^8$	$5.8 \times 10^8$	Faster primary solidification, more prone to cold folds
Liquid thermal expansion, kg/K m <sup>3</sup>	$3.2 \times 10^{-4}$	$2.3 \times 10^{-4}$	Lesser natural convection
Kinematic viscosity, m <sup>2</sup> /s	$5.3 \times 10^{-4}$	$7.94 \times 10^{-4}$	More laminar flow
Surface tension, N/m	0.87–1.05 (much more when oxidised)	0.545–0.563	Weaker solidified shell, more prone to surface cracking

packaging (including beverage cans), construction, and maritime with specific products made out of specific alloys. Magnesium alloys are following suit.

In this book, we try to encompass the present and the future of DC casting technology for aluminium and magnesium alloys with the emphasis on both basics and advances. We have attempted to cover all the activities, and related science and technology from raw materials and melt preparation through final product (Figure 1.8), but the emphasis is on the DC casting process.

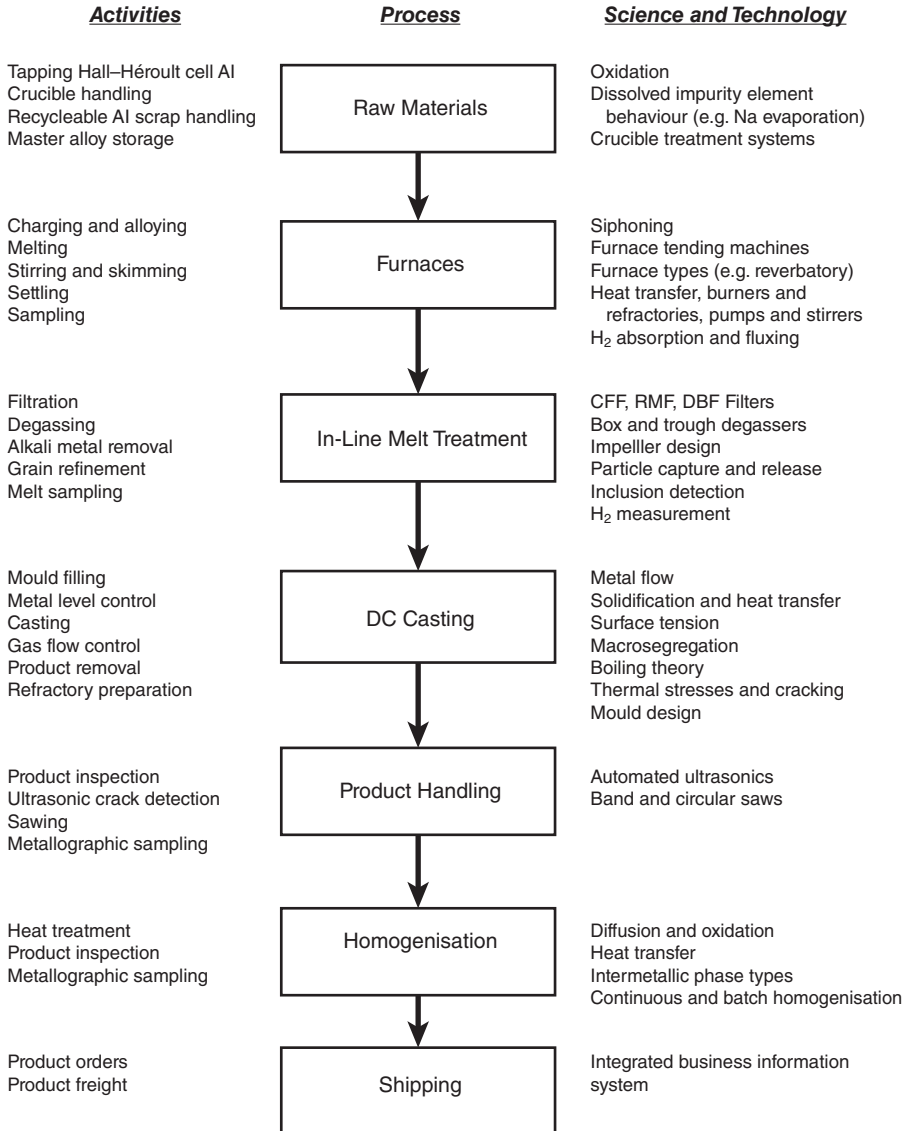

**Figure 1.8.** Activities, science and technology involved in DC casting. CFF, ceramic foam filter; RMF, rigid media filter; DBF, deep bed filter.

## REFERENCES

1. E.F. Emley. *Int. Met. Rev.*, 1976, vol. 21, pp. 75–115.
2. J.F. Grandfield, P.T. McGlade. *Mater. Forum*, 1996, vol. 20, pp. 29–51.
3. D.A. Granger. In *Aluminum Alloys—Contemporary Research and Applications*, Vol. 31, *Treatise on Material Science and Technology*, A.K. Vasudevan, R.D. Doherty, eds. Academic Press, San Diego, CA, 1989, pp. 109–135.
4. L. Katgerman. *Cast Met.*, 1991, vol. 4, no. 3, pp. 133–139.
5. W. Schneider. In *Light Metals 2002*, W. Schneider, ed. TMS, Warrendale, PA, 2002, pp. 953–960.
6. D.G. Eskin. *Physical Metallurgy of Direct Chill Casting of Aluminum Alloys*, CRC Press, Boca Raton, FL, 2008.
7. P. Baker. In *Proc. Symp. Light Metals 1997 Metaux Legers*, 36th Annual Conf. Metallurgists of CIM, 1997, MetSoc, Montreal, pp. 355–367.
8. J. Laing. US Patent 3023, 1843.
9. H. Bessemer. UK Patent 221, 1857; US Patent 4953, 1865.
10. H. Bessemer. *J. Iron Steel Inst.*, 1891, vol. 1, pp. 23–41.
11. M. Wolf. *Rev. Metall.—CIT*, 2001, vol. 98, no. 1, pp. 63–73.
12. S. Junghans. US Patent 2135184, 1938, filed 1936; German Patent 750301, filed 1933.
13. H. Kastner. *Met. Ind.*, 1947, vol. 71, August, pp. 83–85; 106–108; 131–132.
14. T.W. Lippert. *Iron Age*, 1944, vol. 153, no. 8, pp. 48–146.
15. V.I. Dobatkin. *Continuous Casting and Casting Properties of Alloys*, Oborongiz, Moscow, 1948.
16. S.M. Voronov. *Continuous Casting of Round Billets from Light Alloys*, Selected Works on Light Alloys (1946), Oborongiz, Moscow, 1957, pp. 336–362.
17. B. Zunckel. German Patent 678534, 1939, filed 1935.
18. W. Roth. FRG Patent 974203, 1960, filed 1936.
19. W.T. Ennor. US Patent 2301027, 1942, filed 1938.
20. M.B.W. Graham, B.H. Pruitt. *R&D for Industry. A Century of Technical Innovation at Alcoa*, Cambridge University Press, Cambridge, 1990, pp. 251–262.
21. R.G. Wilkinson, S.B. Hirst. *J. Inst. Met.*, 1952–1953, vol. 81, pp. 393–400.
22. W. Roth, E. Weisse. *Aluminium*, vol. 26, no. 7/8, 1942, pp. 134–136.
23. W. Roth. GB Patent 492216, 1937.
24. P. Brenner, W. Roth. *Metallwirtschaft, Metallwissenschaft, Metalltechnik*, 1942, vol. 21, pp. 695–699.
25. W. Roth. *Aluminium*, 1943, vol. 25, pp. 283–291.
26. W. Roth. *Z. Metallkde*, 1949, vol. 40, pp. 445–456.
27. V. Kondic. *Met. Ind.*, 1944, vol. 65, pp. 56–58.
28. W. Patterson. *Aluminium*, 1943, vol. 25, pp. 75–78.
29. V.A. Livanov. In *Proc. of the First Technol. Conf. of Metallurgical Plants of Peoples' Commissariat of Aviation Industry*, Oborongiz, Moscow, 1945, pp. 5–58.
30. V.A. Livanov. In *Aluminium Alloys*, Collection of papers, Oborongiz, Moscow, 1955, pp. 128–168.

31. R.E. Sanders, Jr. JOM, 2001, vol. 53, no. 2, pp. 21–25.
32. G.E. Moritz. US Patent 2983972, 1961, filed 1958.
33. G.E. Moritz. US Patent 3212142, 1965, filed 1962.
34. A.G. Furness, J.D. Harvey. GB Patent 1389784, 1975, filed 1973.
35. R. Mitamura, T. Itoh. US Patent 4157728, 1979, filed 1977.
36. F.E. Wagstaff, W.G. Wagstaff, R.J. Collins. UK Patent Application 2129344A, 1983; US Patent 4598763, 1986, filed 1985.
37. G.M. Apostolou. Aluminium Technology '86, IOM, London, 1986, pp. 149–156.
38. J.F. Grandfield, J.A. Taylor, I.F. Bainbridge. US Patent Application, US 2008/0283212 A1, filed 2008.
39. R.B. Wagstaff, D.A. Salee. US Patent 5582230, 1996, filed 1994.
40. G.J. Binczewski, W.K. Kramer. In Light Metals 1972, W.C. Rotsell, ed. Met. Soc. AIME, Warrendale, PA, 1972, pp. 465–481.
41. E. Herrmann, D. Hoffmann. Handbook on Continuous Casting, Aluminim-Verlag, Düsseldorf, 1980.
42. M.D. Anderson, K.T. Kubo, T.F. Bischoff, W.J. Fenton, E.W. Reeves, B. Spendlove, R.B. Wagstaff. US Patent 7472740, 2009, filed 2004.
43. R.B. Wagstaff, D.J. Lloyd, T.F. Bischoff. Mater. Sci. Forum, 2006, vol. 519–521, pp. 1809–1814.
44. Z.N. Getselev, G.A. Balakhontsev, G.V. Cherepok, V.K. Zinoviev, A.A. Ershova, M.M. Nonin. US Patent 3467166, 1969, filed 1967.
45. Z.N. Getselev. US Patent 3605865, 1971, filed 1969.
46. V.A. Livanov, R.M. Gabidullin, V.S. Shipilov. Continuous Casting of Aluminium Alloys, Metallurgiya, Moscow, 1977.
47. J.F. Grandfield. PhD thesis, 2001, University of Queensland, Brisbane.
48. B.S. You, C.D. Yim, S.H. Kim. Mater. Sci. Eng. A, 2001, vol. 413–414, pp. 139–143.
49. M.V. Chukhrov, I.P. Vyatkin. Continuous Horizontal Casting of Ingots from Metals and Alloys, Metallurgiya, Moscow, 1968.
50. D.M. Lewis. Metall. Rev., 1961, vol. 6, no. 22, pp. 143–192.
51. I. Properzi. US Patent 2710433, 1955, filed 1949.
52. C. Kammer. Continuous Casting of Aluminium, TALAT lecture 3210, 1999. <http://www.alueurope.eu/talat/lectures/3210.pdf>.
53. C.W. Hazelett. US Patent 2640235, 1953, filed 1949.
54. T. Sendzimir. US Patent 2074812, 1937.
55. J.L. Hunter. US Patent 2790216, 1957.
56. S.S. Park, W.-J. Park, C.H. Kim, B.S. You, N.J. Kim. JOM, 2009, vol. 61, no. 8, pp. 14–18.
57. O. Duygulu, S. Ucuncuoglu, G. Oktay, D. Temur, O. Yucel, A. Kaya. Magnesium Technology 2009, S. Agnew, N. Neelameggham, E. Nyberg, M. Pekguleryuz, eds. TMS, Warrendale, PA, 2009, pp. 385–390.
58. W. Park, J. Kim, I. Kim, D. Choo. Magnesium Technology 2011, W.H. Sillekens, S.R. Agnew, N.R. Neelameggham, S.N. Mathaudhu, eds. TMS, Warrendale, PA, 2011, pp. 143–146.
59. C. Brocato. Mater. Sci. Forum, 2010, vol. 630, pp. 243–250.

60. A. Ohno. Proc. 4th Decennial Intern. Conf. Solidification Processing, J. Breech, H. Jones, eds. University of Sheffield, Sheffield, 1997, pp. 17–20.
61. A. Ohno. *J. Met.*, 1986, vol. 38, no. 1, pp. 14–16.
62. A. Ohno. US Patent 4605056, 1986; US Patent 5074353, 1991.
63. F.-W. Bach, S. Schacht, A. Rossberg. *Continuous Casting*, H.R. Miller, ed. Wiley-VCH, Weinheim, 2006, pp. 95–100.
64. U. Holzkamp, H. Haferkamp, M. Niemeyer. *Continuous Casting*, K. Ehrke, W. Schneider, eds. Wiley-VCH, Weinheim, 2000, pp. 94–100.
65. J.W. Evans. *JOM*, 2007, vol. 59, no. 2, pp. 30–38.
66. F. Bijlhouwer. Proc. 11th Intern. Aluminium Conf. INALCO 2010, L. Katgerman, F. Soetens, eds. IOS Press, Amsterdam, 2010, pp. 39–46.
67. P.W. Baker, P.T. McGlade. *Light Metals 2001*, J.L. Arnjier, ed. TMS, Warrendale, PA, 2001, pp. 855–862.
68. V. Sarou-Kanian, F. Millot, J.C. Rifflet. *Int. J. Thermophys.*, 2003, vol. 24, pp. 277–286.
69. J.R. Davis, ed. *Aluminium and Aluminium Alloys*, ASM Specialty Handbook, ASM International, Materials Park, 1994.
70. M.M. Avedesian, H. Baker, eds. *Magnesium and Magnesium Alloys*, ASM Specialty Handbook, ASM International, Materials Park, 1998.