

Introduction

The Rise of Animation in France

If cinema marvelously expresses an age dominated by science, it is because cinema is “scientifically founded on movement.” In effect, cinema relies upon a series of mechanisms designed to produce an illusion of animation. (Guido 2007: 28)

Images remained fixed for 32,000 years. Drawings could only move once the camera was invented and put to work reproducing them 24 times a second, filming and projecting them. That is the real cinematic revolution! Animation is a completely virtual art which logically leads into the synthetic image and the modern world. The modern revolution was born with Emile Reynaud and his projected animation in 1892. Live action cinema with actors is merely a pale copy of reality. It is moving photography. . . . But the moving photograph will never be as magical as the moving drawing! (René Laloux, in Blin 2004: 148)

From the very beginning there was great potential for animation in France. Importantly, the French had built up strong traditions in the visual and graphic arts, scientific inquiry, and theatrical spectacles during the late 1800s and early 1900s. Artists from around the world came to Paris to study the fine arts and decorative arts, leading to one of the richest eras for aesthetic experimentation across the media. A number of avant-garde artists, including Marcel Duchamp, Man Ray, and Fernand Léger, were drawn toward experimenting with the representation of time and motion and became fascinated with animated cinema’s potential. It is true that France never possessed large specialized commercial animation studios during the silent or classical sound eras. Nonetheless, French animation has

always existed and its animators have managed to turn out some incredibly creative and influential animation over the years. The bulk of that work has been produced by a relatively limited number of small animation firms and individual animators, often working parallel to other modern artists, exploring their media and looking for unique aesthetic approaches to animating images. Until fairly recently, animation remained on the economic periphery of French film production. French animation has also suffered from film critics and historians who have concentrated almost exclusively on France's famed avant-garde movements and narrative auteurism. Yet the history of animation is essential for understanding French film culture, its history, and its reception. Fortunately, there has been something of a renaissance in animation production within France over the past 20 years, which has motivated new interest in the long and frequently torturous history of French cartoons.

Animation has always been a more highly visible component of American film production than in France, and Hollywood cartoons have also received much more attention from film studies over the years. American animation began with a wide range of styles, techniques, and subjects during the silent era, much like in France. But American animation quickly became standardized as cartoons shifted from ink on paper to clear cels over painted backdrops. In Hollywood, animation fell into step with many conventions of live action filmmaking. By the 1930s, some major studios, including Warner Bros. and MGM, established their own animation wings while others, such as RKO and Paramount, entered into production and distribution deals with specialized animation companies like Disney and Fleischer. Hollywood's cartoon industry was built around division of labor, recurring characters and cartoon series, plus fixed durations of 6 to 8 minutes. American cartoons also received guaranteed distribution and thus predictable income. Most animation was commercially viable and highly capitalized. While there was creative differentiation from studio to studio, the output remained relatively similar, as even the series titles such as *Merry Melodies* and *Looney Tunes* (Warners), *Silly Symphonies* (Disney), and *Happy Harmonies* (MGM), suggest. Further, since the cartoons were produced under the institutionalized conditions of classical Hollywood cinema, they were also subject to regulation by the Motion Picture Producers and Distributors Association, which included censorship at the hands of the Production Code Administration. Cartoons were a very stable, successful, family friendly component of the American film industry.

By contrast, French animators worked more independently, like their colleagues in the plastic arts, or they formed small firms to create short animated motion picture commercials to be shown before the regular shows in theaters. These advertising contracts could ideally provide regular income and help bankroll more personal sorts of animated films on the side. Yet, as we shall see, animation remained a fragile cottage industry in France, an artisanal practice produced by individual auteurs or very small teams of animators. Although France was home to the world's first large movie studios, Pathé and Gaumont, animation was never a large part of their output. By the 1920s and 1930s, Pathé and Gaumont were primarily distributing independent and foreign films, including American cartoons. They did not have any sort of in-house animation unit during the years of classical cinema. Unlike Disney's animators or directors such as Chuck Jones and Tex Avery at Warner Bros., French animators never had access to long-term contracts, crews of assistants and in-betweeners, professional music and sound effects departments, or staff camera operators to compile and photograph their work. In France, animation teams were small and necessarily self-sufficient, working within an art cinema mode of production. The result is a fascinating cluster of films by individual stylists struggling to survive on the margins of a national film industry that was not really built to support their productions. Despite those conditions and challenges, the contributions of French animation have managed to be strong and varied over the past 120 years. Moreover, even before the first movies by Louis Lumière in 1895, France proved instrumental to the rise of animation and the representation of movement.

Motion picture animation fully exploits the potential of the cinematic apparatus, from camera to lab to projector. Thus, it seems valuable to situate cartoons at the very heart of cinematic technology and practice, rather than treating them as some marginal side-show or second-tier subset of national cinema. *French Animation History* investigates the rise and development of French animation, chronicles the norms and conventions of particular animators and their small, niche studios, and tests how story structures, graphic style, and sound strategies have shifted across time. Importantly, French animation exploits a wide range of techniques, some of which, from the earliest modes of animated pictures to the most contemporary computer generated and motion capture technology, even defy narrow definitions of animated cinema. While there is some reference here to television and other media, this study remains focused on cinema, helping situate animation as a

vibrant, essential facet of film studies. France has also been a major player in exploring and exploiting new technologies. With the advances in computer generated imaging and digital compositing, the distinction “live action/not live” becomes less functional every day with each new development, further shifting various forms of animation to the core of film production today (Denslow 1997: 2). But even from the very earliest forms of motion devices, animation was a fundamental component for the successful recording and projection of moving images.

The Beginnings of Animation

Explanations of the origins of animation typically do not differ much from summaries of the origins of cinema itself. Survey histories often begin by mentioning cave paintings, magic lantern shows, and nineteenth-century motion devices. For many, when *Ice Age's* (Wedge, Saldanha, 2002) woolly mammoth Manfred wanders into a cave only to discover primitive sketches of men killing his ancestors, it is a poignant self-referential acknowledgment of modern animation's place in the history of humanity's deep-seated desire to represent movement. Paul Wells agrees that animation, in one form or another, has almost always been with us and cites Lucretius as describing a mechanism for projecting hand-drawn images onto a screen as early as 70 BC (Wells 1998: 11). Much later, optics and magic lantern shows during the seventeenth and eighteenth centuries were often initiated by scientists but adapted for public presentations of various sorts of lectures and entertainment spectacles. Some historians even argue that once the magic lantern was mass produced in the 1800s, it became “the first medium to contest the printed word as a primary mode of information and instruction” (Gunning 2000: xxvii). Certainly, by the nineteenth century, when the illusion of motion became quite common thanks to a wide variety of toys, scientific devices, and serial photography experiments, there were many amusements and businesses devoted to replicating movement, rather than just presenting still images in a sequence.

Paris, along with London, Berlin, and Brussels, was among the cities boasting networks of important scientists specializing in experiments involving the capturing of fixed images and replication of motion. One of the earliest instruments was the spinning thaumatrope, which might have a drawing of an empty bird cage on one side, and a painted bird on the other.

When the device is spun around fast enough, the viewer's perception joins the two images and a relatively convincing image of a bird in a cage results. This apparatus was initially made available commercially thanks to Dr. John A. Paris in England in the 1820s. Peter Mark Roget and Belgium's Joseph Plateau were also researching "persistence of vision" during this era, continuing a long line of scientific inquiry into measuring how briefly image impressions may remain on the human eye and still be legible. Plateau's phenakistoscope, patented in 1833, allowed more stable illusions via two discs: one static disc had a slit for looking at the second spinning disc, which featured a series of up to 20 images or "phases of action" arranged around its surface. The phenakistoscope, like many early optical toy attractions, is based on circularity and repetition, and its functions are ultimately limited by the small number of images on a disk (Dulac and Gaudreault 2006: 230).

One scholar of early motion devices, David Robinson, states confidently that Joseph Plateau was the first true animator: "Plateau had devised the earliest form of moving picture" (Robinson 1991: 8). French animator Emile Cohl acknowledges Plateau's significance: "Without animation we perhaps never would have had that incomparable invention, Lumière's cinématographe. . . . Most of us owned a phenakistoscope . . . the cinema is right there" (Cohl 2007: 301). A confederation of Belgian scholars concurs: "The cinema was born in Belgium. The animated film was as well since its inventors are Joseph Plateau with his phenakistoscope and the painter Madou who drew the images onto the cut wheels that made the device work" (Sotiaux 1982: 8). As many historians will warn, declaring a "first" anything is often a risky venture. Further, even defining what might qualify as the earliest instance of animation, much less cinema, is still hotly debated. Some might productively argue that spinning discs such as the phenakistoscope function as their own "screen" and thereby qualify as animated cinema, before the fact. It proves more functional, however, to designate such early modes as "animated pictures," as in the case of a flip book, thaumatrope, and phenakistoscope, and "animated photographs" for looping devices exploiting serial photography, while reserving "animated cinema" for devices that exploit projection and/or a screen as part of their illusion of movement (the terms "animated pictures" and "animated photographs" are also employed by Dulac and Gaudreault 2006: 227–244). For our purposes, it seems valuable to investigate briefly several significant figures operating before the launch of Edison and Lumière's recorded live action films of the 1890s, since part of Robinson's important point is that

cinema's first cartoons develop from techniques already pioneered and exploited in optical illusions, photographic processes, and projected spectacles that had become so important internationally during the 1800s.

The zoetrope, also known as "the Wheel of Life," was much like the phenakistoscope, though it functioned thanks to a series of small images on a band of paper, rather than a spinning disc. While not specific to France, zoetropes were manufactured there and became quite popular. During the 1860s and 1870s, one could buy assorted sets of images, arranged in bands, much like comic strips, for zoetropes. Among the available subjects are such illustrative titles as "The Rising Moon," "The Indian Juggler," and "Fly! Leave my nose alone." "The French Revolution" involves heads rolling off bodies, while others exploit abstract visuals. Further, image discs for the bottom of the zoetrope could also be purchased, such as the visually stunning but unsettling "Man Eater," in which a small black figure seems to be flung by centrifugal force into a happy tiger's mouth (for more titles and illustrations, see Robinson 1991: figs. 31–46). Hence a zoetrope could actually have two separate animated cycles going every time it was spun, with the primary series of images on the inside drum and a rotating design or sequence at the bottom. The strip on the inside of the drum provided a horizontal circularity that allowed a minimally narrative "linearization of the action performed by the subjects depicted" (Dulac and Gaudrault 2006: 235), while the bottom disc recalled the radial arrangement of the phenakistoscope. The repetition of a limited number of images in this and other optical toys is in many ways typical of recent computer animation programs such as Flash, exploited so relentlessly by Internet web-page ads in particular. We should see a direct connection between the images that represent a monkey continually running back and forth across the top of an Internet site and the often spellbinding nineteenth-century motion devices of girls eternally jumping rope, horses leaping, or couples waltzing in circles.

Importantly, during the 1860s and 1870s, a variety of devices were developed to allow for the projection of zoetrope bands and other photographic images. The major French figure during this era of early animation devices was Emile Reynaud (1844–1918). In his teens, Reynaud had been an apprentice in mechanical engineering for precision machinery, where he learned to work on optical and scientific instruments. He pursued industrial design but also studied photography with Adam Salomon and learned magic lantern skills from a famous Catholic scientist and educator of the era, Abbé Moigno, also known as "the apostle of projection" (Mannoni 2000: 365). A popular scientist, subscribing to *La Nature*, the influential journal

devoted to scientific applications for the arts and industry, Reynaud became frustrated with the poor image and color quality in the zoetrope and other optical devices, so he designed a superior alternative, the praxinoscope, which was patented in 1877. A series of 12 drawn images, color lithographs, on a flexible strip of paper was placed within a cylinder. In the center, a rotating “cage” of mirrors reflected the surrounding images as they passed by. The entire device looks a bit like a toy merry-go-round. Viewers looked directly at the sequence of stable images momentarily reflected on a mirror’s face, rather than through slits. A candle in the middle could provide extra light for crisp resolution. During 1878, Reynaud marketed his praxinoscopes, along with packets of replaceable strips of images which typically involved subjects such as jugglers, animal tricks, or cavorting children. One series was even called “Baby’s Lunch,” predating Lumière’s famous film by nearly two decades. In the more elaborate “theater” versions sold in folding wooden boxes, a small rectangular peep hole provided the viewer a perfect vantage point onto the reflected series of images framed by drawn sets, creating a child’s replica of a small theatrical stage.

By 1879 Reynaud was producing a variation, the praxinoscope-théâtre, which printed isolated, colorful characters on the strips. An additional mirror allowed the viewer to project a background into the scene, so, for instance, a juggler could be seen in an interior room setting or outdoors in a garden. This was an early form of composite animation and delivered a new sense of depth to the presentations. Reynaud claimed eventually to have sold 100,000 praxinoscopes, which appeared in various models over the years, including one that was driven by an electric motor.

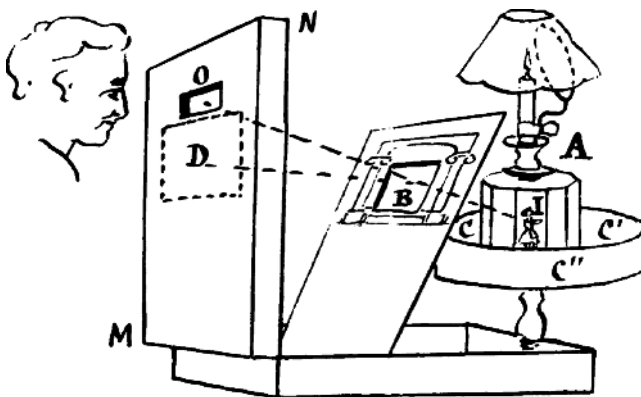

Figure 1.1 Praxinoscope patent, Emile Reynaud, 1878.

During the early 1880s Reynaud also experimented with projecting the drums of spinning images. When he presented a new projecting model of the praxinoscope to the Société Française de Photographie in 1880, for instance, he explained that the ideal goal would be for someone to invent a way to project photographic images for a better illusion of movement than drawn figures could generate (Mannoni 2000: 374). Reynaud's early prototype projector used 12 glass slides strapped together into a flexible belt of images for projection. This device also involved combining the moving figures from the glass slides with painted static backgrounds. They were both reflected onto the same mirror during projection for the composite image. But clearly Reynaud saw the continued limitations of his short series of hand-drawn images printed on slides. In 1888, Reynaud patented an important variation on the praxinoscope that allowed the projection of a large, clear, longer string of pictures.

This device, renamed the "théâtre optique," or optical theater, showed a series of images that were initially painted on glass plates connected by a flexible band that unwound from one reel and rewound onto another. These slides could briefly lie flat in front of the light source for sharp projection onto a mirror before being reflected onto the final screen. Reynaud next painted on a flexible roll of gelatine bordered by cardboard or cloth. This strip wound its way through a series of rollers before passing by the mirrored surface for projection. One of the inspirations for the overall design was apparently the mechanics of the nineteenth-century bicycle with its large front wheel, long chain, and smaller rear wheel, driven by pedals and a crank (Myrent 1989: 193). The initial patent application carefully outlined the components for the apparatus, including gears, rollers, and take-up reels, but he also left vague the definitions of the "flexible band," and allowed that the machine would work whether the "successive poses" were opaque or transparent, and he even acknowledged that the designs could be printed mechanically onto the malleable strip. A catalogue for a 1982 exhibition on "100 Years of French Animation" credits Reynaud with launching a new medium: "With characters drawn and colored on a large perforated strip of film, animation existed before the cinema!" (Maillot 1982: n.p.).

Importantly, Reynaud's optical theater allowed "unlimited durations allowing for real animated scenes" (Lonjon 2007: 201). The patent explained that this device decisively surpassed such repetitive, circular devices as the zoetrope and praxinoscope (Reynaud and Sadoul 1945: 55). A linear "show" was now possible rather than the spinning discs and strips with their brief

loops that had preceded the optical theater. As Nicolas Dulac and André Gaudreault point out, “Reynaud’s apparatus thus went beyond mere gyration, beyond the mere thrill of seeing the strip repeat itself . . . narrative had taken over as the primary structuring principle.” Reynaud offered “a new paradigm within which narration would play a decisive role” (Dulac and Gaudreault 2006: 239). Individual titles lasted from 8 to 15 minutes and consisted of 300 to 700 images, so the duration of Reynaud’s subjects far exceeds the subsequent 50-second Lumière films, anticipating instead the length of eventual one- and two-reel short films. Pauses were built into the presentations, and they still seem to have had a rather slow projection time, averaging one second per image. However, Reynaud also designed the drawings to allow for some repetitions. For instance, when Harlequin first sneaks over the wall in *Pauvre Pierrot* (*Poor Pierrot*, 1892), he acts rather hesitant. Reynaud would stop advancing the band of animation, reverse it to show the character climb back up the wall, then crank it forward again as Harlequin finally decided to drop into the garden for good (Auzel 1998: 68). When a character danced with delight, Reynaud could also draw the frames in such a way that they could be shown forward, then backward, then forward again, but it looked like three sequential dance steps. Significantly, such back and forth maneuvers were possible because Reynaud was actually projecting two images. A magic lantern projected the static painted slide of the background set which was constant, while only characters and occasional objects were drawn on the moving strip. Thus, a composite image resulted that prefigures later cel animation, where the objects changing from frame to frame were drawn on clear sheets set on top of their fixed, painted setting. So, even if a character were reversing his actions, or briefly disappearing altogether, there was always a constant projected setting visible. It would be several decades before any other animator would separate the figure and ground for animated motion pictures.

Emile Reynaud’s invention back-projected the images onto a screen, which reportedly dimmed and possibly distorted the initial image somewhat for the audience watching the translucent screen from the other side. Initially, he relied upon a gas lamp powered by igniting oxygen and hydrogen for a bright light, but when bright electric lamps became available Reynaud switched over to that safer, cooler option. Beyond the moving images, an important part of the show was also the “man behind the screen” presenting his spectacle. Emile Reynaud’s name figured prominently on the advertising posters for the Musée Grévin wax museum. *La Nature* even featured a famous illustration of Reynaud at the controls, operating the

optical theater, and one historian points out that Reynaud looks superb in the midst of the apparatus, with his hands turning the controls: “He resembles Captain Nemo at the helm of the *Nautilus* – 20,000 leagues under his dreams” (Tchernia 1998: 5). France’s *Figaro* featured a story in 1892 declaring that Reynaud’s ingenious machine “creates characters whose expressions and gestures are so accurate as to give a complete illusion of life” (cited in Cayla 2007: 15).

Reynaud signed an exclusive contract with the Musée Grévin in Paris to present his shows, which he called “lighted pantomimes.” Other Grévin acts performed in between each of his presentations. His earliest program included *Poor Pierrot*, which premiered on October 28, 1892 as one of three different films he presented that evening. *Poor Pierrot*, based on the well-known pantomime, features the trickster Harlequin hiding in a moonlit garden, tormenting Pierrot who has arrived to serenade Columbine, the woman of both their dreams. The mime action takes place in distinct scenes, with Harlequin showing up first to flirt with Columbine, then hiding when Pierrot arrives. Harlequin succeeds eventually in frightening Pierrot out of the yard, leaving the field free for Harlequin to woo Columbine. *Poor Pierrot* successfully synthesizes conventions from live theatrical performance with those of the comic strip. Its narrative space is shallow, with a playing space that reflects a stage setting, though the painted door in the back garden wall “opens” several times to create an increased sense of depth, reinforced by the brightly rendered moonlight pouring forth through the opening into the garden. *Poor Pierrot* contained roughly 500 drawings and initially ran for 10 minutes, and its premiere was accompanied by a piano piece written specifically for the narrative by Gaston Paulin. There were even specific songs sung in time with the characters’ gestures, as well as tiny silver tabs that triggered sound effects as they passed by (Lonjon 2007: 125–128; see also Leslie 2002: 4). Georges Sadoul writes, “Reynaud’s first ‘pantomime lumineuse’ is also the first masterpiece of the animated cartoon” (Sadoul 1972: 278) (see Plate 1).

Clown et ses chiens (*The Clown and his Dogs*), the second show on the original program, was made up of 300 images of a clown presenting various dog tricks, and ran for roughly 8 minutes. It was intensely colored and accompanied by a fast-paced waltz. Reynaud often began his presentations with *Le Bon Bock* (*A Good Beer*), a 15-minute comical playlet featuring antics among four characters at a village inn, including a waitress, thirsty hiker, a kitchen boy who repeatedly drinks the hiker’s beers, and another traveler passing through. Importantly, the Grévin’s manager had invited a magician

he knew, Georges Méliès (1861–1938), to Reynaud’s premiere. Méliès, who at this point was projecting magic lantern slides as part of his own theatrical spectacles, met with Reynaud right after the show. When Reynaud explained his labor-intensive process, the magician apparently inquired about whether some mechanical process for reproducing the images might not be possible. Reynaud mentioned that he was aware of Thomas Edison’s experiments in the US but told Méliès he personally had been trying since 1888 to come up with his own more efficient process. So far the solution had eluded him (Lonjon 2007: 129–130).

Reynaud’s illuminated pantomimes quickly became a central attraction for the Musée Grévin where they were part of the wax museum’s daily program, running ten to twelve times on weekend days. The Grévin contract prohibited Reynaud from presenting his spectacle anywhere else as well as from selling the apparatus itself, something Reynaud had initially planned on. However, later that year the sponsors of a large charity event in Rouen convinced Grévin’s manager to lend out Reynaud and his device. During one day, December 3, 1892, Reynaud gave 12 performances of the three films to a total audience of 1,300 spectators. The next day, a Rouen newspaper praised Reynaud’s “elegant entertainment”: “The scenery, viewpoint, characters, and costumes were all stunning successes. Everything had accurate depth and correct coloring. This is really theater in action and the illusion was perfect. We only regret that this theater could only stay in Rouen for the one day” (Lonjon 2007: 131). Back in Paris, Reynaud continued to sell his original praxinoscopes via large department stores. But he also had to repair, update, and replace his optical theater strips regularly since the gelatine surfaces were delicate, and there were no copies, so the bands of images wore out steadily from the constant use.

Thus, Reynaud provides a good model for the strengths and weaknesses surrounding the production and exhibition of animated pictures prior to the development of motion picture film stock and its ability to reproduce countless identical copies from a negative. While Reynaud paved the way in terms of subjects, exhibition, and marketing, the long-term limitations of his one-of-a-kind bands of images were obvious. When he was not selling praxinoscopes or projecting the optical theater shows, he was kept busy designing and drawing new episodes in order to continue his profitable Grévin performances. Reynaud’s teenage son André also helped paint in the characters. Yet while this sort of labor-intensive moving picture mode did attract a steady audience, it was necessarily limited to one physical venue, so the profits were fixed; without an ability to copy his work, there was no hope

of multiple projections in a number of theaters simultaneously. He was an artisan soon to be overtaken by the sort of mechanical reproduction that would be made possible by the highly capitalized corporate research and development of Thomas Edison and the Lumière family.

Among Reynaud's subsequent hand-made shows was *Autour d'une cabine* (*Around a Bathing Hut*), completed in 1894 for the 1895 season at the Musée Grévin. This new subject comprised 660 images, running roughly 12 minutes. Historian Georges Sadoul called it "the richest and most complex" of Reynaud's works. In addition to the bathers and their comical actions at the beach, *Around a Bathing Hut* included sea gulls circling in the sky, which opened up the action far beyond the more theatrical settings from the earlier titles (Sadoul 1949: 15). The slight diagonal perspective onto the beach scene, with a diving board intruding into the space at an angle, provides a more dynamic setting than the straight-on *Poor Pierrot* and even anticipates the framing of later Lumière films of bathers diving off piers. *Around a Bathing Hut* began with bathers frolicking on the pier, where one pushes another into the water, followed by the arrival of a "Parisian" couple. While the man goes into his beach hut to change, the wife and her dog bump into a flirtatious older dandy. When the woman enters her own hut, this fellow stoops to peek in the keyhole. Her husband soon emerges in his swimsuit and kicks the old voyeur. The couple then takes a swim, but once they return to the beach in the foreground to change back into regular clothes they find the dandy waiting in her hut. The husband pushes the man into the sea and then the little dog chases him off out of the frame. A boat heads past and its unfurled sail reads "End of the show." Thus this presentation unfolds in a series of chronological scenes that all play out on the unified section of beach, and much like Jacques Tati's *Les Vacances de M. Hulot* (1953), the story is a loose collection of anecdotes. Once again, this was not a silent presentation. Gaston Paulin wrote two songs for *Around a Bathing Hut*, one called "At the Beach" and the other "The Sea Gulls," which were performed behind the screen beside Reynaud, by a Cuban musician, Albert Faucon (Lonjon 2007: 142).

With the arrival of Edison's kinoscope and then Lumière's cinématographe screenings, Reynaud's one-man operation, with its recurring titles, soon became a quaint and dated attraction. Yet, Reynaud had developed important and influential animation techniques that helped move animated pictures beyond the repetitive sequential poses of the zoetrope. His painted human figures often moved toward or away from the audience, employing far greater depth of field and more accurate and fluid character motion than

previous motion devices. Georges Sadoul points out that Reynaud made use of the zoological findings in Eadward Muybridge and Etienne-Jules Marey's serial photography to make his own drawn horses gallop correctly and to add complex shifts in body and gesture to other characters (Sadoul 1949: 14). His significance can also be judged by the fact that an estimated half a million people attended his projections between 1892 and 1900, when Reynaud lost his contract at Grévin and was forced to discontinue his shows (Bendazzi 1994: 5). As David Robinson argues, "Indisputably the greatest animator of the pre-cinema era, Emile Reynaud, with his *Pantomimes Lumineuses* of 1892, provided the ultimate link between these six decades of animation devices and the motion picture proper" (Robinson 1991: 16).

Emile Reynaud's projected drawn images certainly count as moving picture animation and his shows inspired both Thomas Edison and the Lumière brothers. The Lumières had indeed visited both the Musée Grévin and Reynaud's workshop in 1894. During the late 1890s, Reynaud even used motion picture cameras to film actions, including the popular comic act Footit and Chocolate performing a pantomime version of William Tell against a black background. Such presentations were billed as animated photo-paintings (Auzel 1998: 94–95). Reynaud did not use the cinematic images themselves, rather he cut them up and colored them or traced and redrew their actions, exploiting the camera simply to streamline his process (see Bendazzi 1994: 5–6; Myrent 1989: 199). This animation technique anticipates the rotoscope developed by Max and Dave Fleischer during the 1910s, to say nothing of motion capture technology today. Interestingly, Louis Lumière also filmed the Footit and Chocolate act in 1900. Thus Reynaud's work is closely entwined with motion studies and entertainment during this era and should not be reduced to an odd, isolated side-show in motion picture animation's history.

Unfortunately, Emile Reynaud smashed his apparatus and threw most of his remaining film strips into the Seine after Musée Grévin ended his contract. Very little remains from his many intricate works, though the French Centre National de la Cinématographie (CNC) released a restored version of a portion of *Poor Pierrot* in 2007 and partial prints of *Around a Bathing Hut* circulate. These two titles had been saved by another son, Paul Reynaud. Emile Reynaud's final project involved trying to invent a commercially viable stereoscopic motion picture camera and projector, which never found financial backing. Yet Reynaud should be credited as a founding figure of international cinema alongside Edison and Lumière.

Kristen Whissel asserts that though the latter two invented more practical and marketable devices, “Reynaud first simulated movement and projected shows upon a screen” (Whissel 2007: 303). Thus, if Louis Lumière can be said to have invented a more complete form of cinema by getting Edison’s kinoscope images “out of the box,” projecting them for multiple viewers, then surely Reynaud should be credited as successfully getting animation out of the zoetrope cylinder and onto the screen for a popular, paying audience, all before reels of film wound their way through Edison’s kinoscope or Lumière’s cinématographe.

Among the other essential figures in the development of animation, and cinema in general, is the famous photographer and scientist Eadweard Muybridge (1830–1904), who was ultimately influenced by French advances. During the 1870s and 1880s, Muybridge was a leading figure in serial photography, designing elaborate experiments involving banks of cameras to record sequentially animal and human motion. Muybridge sought to understand animation locomotion more fully by breaking down real movement via discrete photographs. His wet plates were exposed in carefully timed sequences, sometimes with exposure times as fast as 1/500th of a second, and he employed banks of individual cameras, often using 24, triggered one second apart. He arranged the photos onto plates to compare specific poses frozen in time by his apparatus. But he also transferred them onto glass discs, sometimes tracing the original photographs, other times striking positive copies from negatives, which were then projected by the zoopraxiscope. Many of Muybridge’s subjects were animals and people walking laterally past his lenses, as well as naked men and women performing everyday chores. Muybridge was an important early animator, copying onto discs photographic records of people and animals undertaking some brief practical task. However, his famous horse experiments of the 1870s were of relatively poor quality. It was only after a European lecture tour, where Muybridge met Etienne-Jules Marey, among others, that his best, most scientifically useful work began. Upon returning to the United States, he set up his lab in 1884 at the University of Pennsylvania, strongly inspired by Marey in particular.

France’s Etienne-Jules Marey (1830–1904) experimented with sequential “chronographic films” and time-lapse photography during the 1880s and 1890s in order to “de-animate” or break down motion into various static records to study it better, sometimes in marvelously beautiful multiple exposures. However, Marey came to his motion studies directly from the world of medicine and science. He was never interested in being the sort of

public entertainer who would come to dominate early cinema and animation. Rather, Marey was an extremely accomplished physiologist who saw the practical merits of optical devices and photography for conducting and then demonstrating his research. He began his medical career interested in precise measurement of blood flow and other mechanics in humans and animals. He invented, among other things, the polygraph and the first cardiograph before inventing chronophotographic equipment to analyze movements of everything from tiny insects to humans to elephants. Much of his research work at his elaborate laboratory station was supported by the French government, and he published widely, from exemplary articles in *La Nature* to influential and often quite beautiful books on human and animal movement, including *La Machine animal* (*The Animal Mechanism*, 1873). Many of his initial chronophotographs involved multiple exposures on one large image, which resulted in fascinating, complex photos that greatly influenced later artists, anticipating, among others, Giacomo Bala's *Dynamism of a Dog on a Leash* and Marcel Duchamp's *Nude Descending a Staircase*, both 1912. For some studies, his photographed subjects would wear thin reflective metal strips on black outfits, to further isolate body parts, and these suits resemble today's motion capture suits. The precise representations by researchers like Marey also participated in the shift toward modernist representations of lived experience and helped boldly document the rift between knowledge and the limits of human perception. New functions of visual culture were being forged at a rapid rate, especially in France where a surprisingly high number of popular science societies and a vast slate of expositions allowed for scholars, researchers, and practitioners from many nations and disciplines to interact productively and follow-up on one another's experiments and triumphs (for more on modernism and shifts in visual culture, see Crary 1992).

Marey's various chronophotographs, including the famous rifle-camera invention, were constantly upgraded for his various research tasks. The initial 1882 rifle exposed a sequence of 12 images on a rotating photographic disc. Marey had read about Muybridge's horse photos in *Nature*, but he was also impressed by Pierre-Jules-César Janssen's photographic revolver which took low quality but groundbreaking photos of the planet Venus passing between the earth and sun. Already in 1888 Marey was exposing 20 images per second on a roll of sensitized paper and later he exposed longer, 90 mm wide transparent gelatine strips for large clear negatives, before finally switching to flexible 35 mm Eastman celluloid stock in the 1890s. Interestingly, Marey, Reynaud, and Thomas Edison all displayed their recent

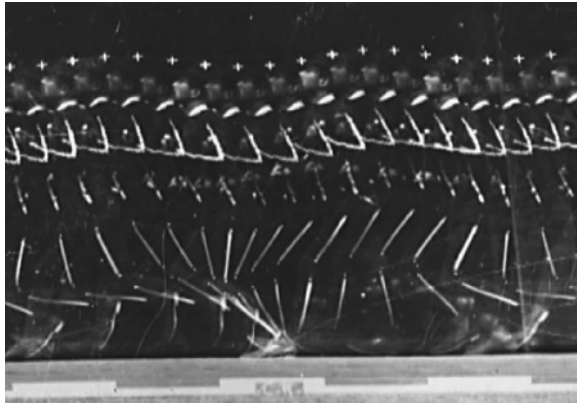

Figure 1.2 Marey's multiple exposure, produced and photographed by Etienne-Jules Marey, 1881.

inventions at the 1889 Universal Exposition in Paris, and Marey's work was greatly celebrated by physiologists, popular scientists, and photographers alike. His recurring obsessions included the study of flying birds, as well as the photographic documentation of flowing liquids and even air currents. Much of his work eventually proved crucial for early studies of air travel. For recording tiny insects scurrying past his lens, Marey reportedly managed to reach exposure times of $1/25,000$ th of a second (Braun 1992: 166). Marey investigated a wide range of tactics for projecting his various recorded series of photographic images, including tracing the images and even cutting up the film strips to place individual images on his crude projector. However, while Marey could reconstruct movement between his animated photographs, he was first and foremost a motion scientist. Marey wanted an apparatus to slow down some movements and speed up others: "He was not after a machine that would replicate the continuity of perceived movement. . . . The idea of reproducing movement as the unaided eye grasps it would be absurd" to Marey (Braun 1992: 174). Further, Marey was aided over the course of 14 years by Georges Demeny, a talented assistant who became frustrated by Marey's relative lack of interest in the potential for public projections or sale of their devices.

In 1892, Marey and Georges Demeny demonstrated their projecting phonoscope with a 24-frame shot of Demeny mouthing the phrases "I love you" and "Vive la France." Demeny was interested in using close-up shots of speaking subjects to help teach lip-reading to the deaf. By 1894, Marey and Demeny were filming and projecting a host of subjects. Yet the fixing and

“re-animating” of images remained a research and educational venture for Marey, rather than a potentially lucrative entertainment spectacle. He had no interest in the sort of public showings that made Reynaud famous. Nonetheless, many of his chronophotography experiments also hold value as stunning visual presentations of moving pictures. As historian Marta Braun points out, Marey’s work dealt head-on with the reconceptualization of time and space, influencing artists, scientists, and philosophers, including Henry Bergson: “Marey’s imagery, embedded in the discourse of nineteenth-century science, comes to belong to the canon of early twentieth-century art and aesthetic modernism. . . . Marey’s work – his subject, movement, and his method of mechanical decomposition – is at once the beginning of a new synthesis of science and labor and the focal point of the artistic dissolution of the space-time continuum” (Braun 1995: 88). This deconstruction of the visual and the ensuing exploration of rhythm between still images inspired French researchers and artists alike. According to Laurent Mannoni, “Marey’s film strips are true embryonic stages of the cinema, priceless evidence of the genius of this great researcher, and just as importantly remarkable works of photographic art” (Mannoni 2000: 343). While Marey’s devices may have “paved the way for the study of movement on a frame-to-frame basis” (Furniss 2007: 76), they did not yet motivate a boom in French animated pictures for popular entertainment. His animation remained closely tied to his laboratory.

By the mid-1890s, when Edison and Lumière had launched their moving picture companies, animation entered a new phase, with flexible celluloid film stock becoming the standard mode of support for the images. However, even during the rise to dominance of the 35 mm film stock, there were alternatives. Beyond the individuals and devices mentioned so far, there were scores of other techniques for representing motion, including both photographic and non-photographic means. The mutoscope, for instance, was a very popular and profitable apparatus for a short time during the 1890s. It was initially a single-viewer peep show device, something like a later roldex, with individual cards on a drum that rotated. It was a mechanical improvement on the flip book, capable of advancing a thick stack of cards at a constant rate. The images were often recorded with a camera, transferred to the cards, then shown in mutoscopes, where the viewer turned the crank to control the sequence of printed cards. The subjects were often strongly voyeuristic and some famously erotic. A number of subjects were also hand-drawn or printed mechanically. This period of competing modes for animating images proved vital and inspiring



Figure 1.3 Marey's dragonfly, produced and photographed by Etienne-Jules Marey, 1891.

for later animators and helped prepare their audiences for diverse spectacles and increasing uses of moving, drawn images. Variations on the mutoscope would later become a useful tool for animators previewing and testing their sketches for fluid motion and accuracy.

Beyond the devices and presentational modes mentioned thus far, there was another interesting subset of motion picture animation at the turn of the century which is often overlooked today. During the 1890s, Germany's Gebrüder Bing Company devised a small projection device for children that involved short lengths of flexible film stock that looped through a small projector. The images, in black and white as well as color, were printed via lithography onto a piece of Edison's 35 mm film stock. The images sat sideways on the film strip, so passed horizontally through the projector. Typical subjects included soldiers marching across the frame, acrobats and dancers performing, or children skipping rope. These attractions were brief, repetitive, and aimed at children, and sold in packs of eight. According to Robinson, "These eight films may be regarded as the origins of [the] animated cartoon in the cinema" (Robinson 1991: 18). The Bings, whose projectors are already described in Henry Hopwood's *Living Pictures*, published in 1899 (Hopwood 1970), were quickly followed by other entre-

preneurs selling these expensive children's projectors, including France's Lapiere Company. These devices are another important link between the motion devices aimed at private use in the wealthy nineteenth-century home, and the earliest forms of film production and exhibition. Clearly, the animated cinema is a fascinating series of experiments, devices, and marketable products that does not begin with any single cartoon or individual. It was invented over the course of the entire nineteenth century and many of those investigations and accomplishments took place in France or were directly related to French research.

Stop-Motion Animation Attractions

In part because of the rich context of nineteenth-century France's fascination with technology, French filmmaking quickly led the world in fantasy, science fiction, and special effects techniques. Certainly, Georges Méliès established the sub-genre of the "trick film" which typically exploited stop-motion pixilation of actors and objects. However, much of his work avoided frame-by-frame construction of images, but rather exploited substitutions of objects to represent transformations. As Giannalberto Bendazzi remarks, "Screening Méliès films today is like viewing an animated film . . . without animation" (Bendazzi 1994: 11). Importantly, Georges Méliès blurred the lines between live action and animation in productive ways and encouraged others to investigate methods for stopping real time and manipulating individual items between the filmed frames. On stage, before his famous trick films, Méliès regularly performed live magic acts and illusions with trap doors and lighting effects to create sudden changes as he seemingly transformed objects before the audience's eyes. He had also incorporated some lightning drawing techniques, appearing as a dessinateur express, quickly sketching portraits and caricatures of famous people, including Queen Victoria, during 1896, years before J. Stuart Blackton's lightning sketches in America (Crafton 1993a: 50). However, rather than expand on frame-to-frame animation, Méliès soon specialized in pixilation and fantastic effects. He was intent on making cinema parallel his theatrical spectacle via performance illusions rather than exploring its own full potential to animate drawings (Mitry 1967: 117).

Thanks in large part to Méliès, French cinema offered high quality special effects films, many accomplished via in-camera manipulation but also with profilmic trickery, so that the pixilation of objects, for fantasy or comic

purposes, became a common strategy from the start. Stop-motion pixilated scenes helped update the sort of illusionist performances that were so popular in the late nineteenth century. Assorted objects could be filmed with a combination of regular motion, fast motion (undercranking the camera to make the process look slightly sped up), or by stopping the camera, moving something, then starting the camera anew. Pixilation has long been a favorite technique for amateur and student filmmakers as well who delight in exploiting the camera's ability to speed up clouds passing in the sky or make a friend, sitting on the floor, seem to "drive" himself down their school's corridors. Further, digital video cameras today make pixilation as easy as the push of a button, proving a continuing fascination for stop-start image technology that "moves" static objects or reduces real movement down to stroboscopic effects.

One other major participant in the cinema of attraction trick films is Segundo de Chomon (1871–1929), a Spanish immigrant who became a key filmmaker for Pathé where his work, such as *Sculpture moderne* (*Modern Sculpture*, 1908), combined the conventions and staging of the magic act with pixilation. His films were inspired by Méliès and erased barriers between realism and fantasy (Viminet 2007: 35). Chomon was a master at spectacular special effects, including stop-motion tricks such as his character "Slippery Jim" pulling bicycle parts out of his sport coat pockets, rapidly assembling them into a real bike and then riding it on top of a train in composite shots during *Pickpock ne craint pas les entraves* (*Slippery Jim*, 1909). Chomon's work animates objects and exploits editing to substitute one object for another. In his famous *Electric Hotel* (1908), suitcases unpack themselves, brushes polish boots on their own, and the female guest's long hair braids itself. However, beyond occasional instances such as lines being scratched on subsequent frames of the film's negative to represent shocks pulsating from the hotel's electric system, Chomon's effects remain rooted in pixilation. One exception, *Chiffonniers et caricaturistes* (*Artistic Rag-Pickers*, 1908), briefly allows Chomon's performers to generate comical portraits in the lightning sketch tradition (Abel 1994: 281–282). Unfortunately, most of Segundo de Chomon's work remains lost. A recent study attributes many modes of animation to him, including silhouettes and drawing on paper, but no concrete evidence exists that can corroborate the catalogue notations and anecdotal evidence relating to this pioneering filmmaker's animated output (Tharrats 2009: 74–84).

Cinema's first attempts to adapt animated toys, scientific motion photography, and comics, among other generating contexts, reinforced the

nearly magical aspect of the first animation for spectators. Much of the earliest work by animators clearly counts as what Tom Gunning (2006), André Gaudreault (Dulac and Gaudreault 2006), and others have labeled attractions, though not all may qualify as full-fledged “cinema” attractions. This famous phrase designates early cinema’s dominant tendency to present overtly exhibitionistic displays to the spectator. Much like the later shocks and attractions theorized and practiced by Sergei Eisenstein, an attraction shows little evidence of character development, diegetic coherence, or narrative logic, and is specifically designed to grab the attention of the viewers and hopefully even surprise them. The first animated motion pictures gradually shift away from the “player mode of attraction,” such as a zoetrope or mutoscope, to a “viewer mode of attraction,” in which the spectator takes a more passive role, and this certainly would hold for Reynaud’s optical theater. Narrative, as we shall see, comes more slowly to dominate animated cinema than live action films, while the various forms of animation take great advantage of cinema’s ability to display its power to create illusions. The subject matter generally remained minimal, exhibitionistic gags.

During the late 1800s, France provided the most vital breeding ground in the world for scientific and aesthetic experimentation with the moving image, and it also boasted a variety of crucial venues for displaying those results. Not only was there a strong tradition of performance and a wide range of spectacles that could incorporate the latest technological advances, there was also an intricate network of professional organizations, publications, and conferences to encourage the verification and sharing of new inventions. Further, France had the added advantage of regular international conferences devoted to science and industry. It was, therefore, quite common for entrepreneurs and inventors from across Europe and the Americas to pass through Paris, and thus not only could Georges Méliès attend both the premiere projections by Emile Reynaud and Louis Lumière, but people like Thomas Edison could also meet and chat with Europe’s motion image pioneers at France’s international congresses and exhibitions. From the earliest motion toys to serial photography to Lumière’s cinématographe, France helped forge the concepts and deliver the devices that would launch animation throughout world cinema.