

1

Introduction to Line-Commutated HVDC

1.1 HVDC Applications

Thyristor-based high-voltage direct-current (HVDC) transmission has been used in over 150 point-to-point installations worldwide. In each case it has proven to be technologically and/or economically superior to AC transmission. Typical HVDC applications can be grouped as follows:

- *Submarine power transmission.* The AC cables have large capacitance and for cables over 40–70 km the reactive power circulation is unacceptable. This distance can be extended somewhat with reactive power compensation. For larger distances, HVDC is more economical. A good example is the 580 km, 700 MW, ± 450 kV NorNed HVDC between Norway and the Netherlands.
- *Long-distance overhead lines.* Long AC lines require variable reactive power compensation. Typically 600–800 km is the breakeven distance and, for larger distances, HVDC is more economical. A good example is the 1360 km, 3.1 GW, ± 500 kV Pacific DC intertie along the west coast of the United States.
- *Interconnecting two AC networks of different frequencies.* A good example is the 500 MW, ± 79 kV back-to-back Melo HVDC between Uruguay and Brazil. The Uruguay system operates at 50 Hz whereas Brazil's national grid runs at 60 Hz.
- *Interconnecting two unsynchronized AC grids.* If phase difference between two AC systems is large, they cannot be directly connected. A typical example is the 150 MW, ± 42 kV McNeill back-to-back HVDC link between Alberta and Saskatchewan interconnecting asynchronous eastern and western American systems.
- *Controllable power exchange between two AC networks (for trading).* The AC power flow is determined by the line impedances and it cannot therefore be controlled directly in each line. In complex AC networks it is common to observe loop power flow or even overloading or underutilization of some AC lines. Many HVDC systems participate directly in trading power and one typical example is the 200 MW, ± 57 kV Highgate HVDC between Quebec and Vermont.

There are other less common applications of LCC (line-commutated converter) HVDC technology, including the 300 MW Levis De-Icer HVDC project. Here, one standard HVDC converter station – a

converter from a Static Var Compensator (SVC) – is used to provide a very high DC current of up to 7920 A (feeding essentially a DC short circuit) to enable heating of remote Canadian overhead lines in order to prevent ice buildup.

An important argument for selecting HVDC instead of an AC for a new transmission line is the contribution to the short-circuit level. High-voltage direct current is able to limit the fault current and therefore it will not require the upgrading of substation equipment.

Figure 1.1 shows a comparison of costs for DC and AC transmission lines. In the case of HVDC the initial capital investment is much higher because of the converter costs. As the transmission distance increases, the benefits of DC offset the capital investment and at certain distance the total cost of an HVDC system is same as an AC line. The breakeven distance is in the range of 40–70 km for submarine cables and in the range of 600–800 km for overhead lines. Figure 1.2 shows an aerial view of the

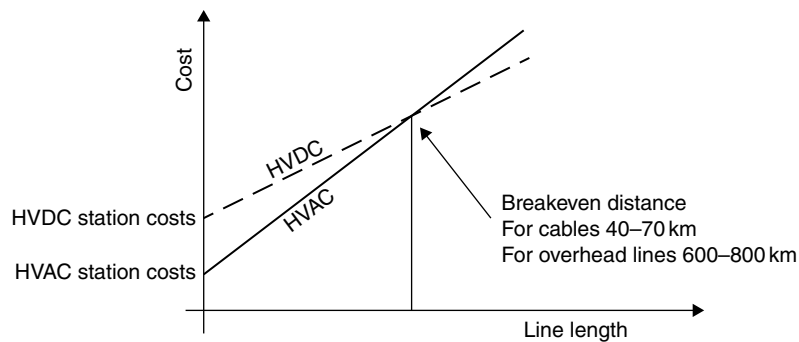

Figure 1.1 HVDC and HVAC transmission cost comparison.



Figure 1.2 Terminal station of Moyle HVDC interconnector (Bipole 2×250 MW, ± 250 kV, with light triggered thyristors, commissioned in 2001). Reproduced with permission of Siemens.

terminal station of the 500 MW Moyle HVDC link. This HVDC enables a controllable bidirectional power exchange between Scotland and Northern Ireland.

1.2 Line-Commutated HVDC Components

Figure 1.3 shows a typical LCC HVDC schematic interconnecting AC systems 1 and 2. It consists of two terminals and a DC line between them. Each terminal (converter station) includes converters, transformers, filters, reactive power equipment, control station and a range of other components. There are two DC lines in this figure while one line is at ground potential.

As shown in Figure 1.3, the major components of an HVDC system include:

- *Converters.* They typically include one or more six-pulse thyristor (Graetz) bridges. Each bridge consists of six thyristor valves, which in turn contain hundreds of individual thyristors. With large systems, bridges are connected in series in 12-pulse or 24-pulse configuration. The 12-pulse converters can be connected into poles or bipoles.
- *Converter transformers.* These are a special converter transformer type, which is somewhat more expensive than typical AC transformers of the same rating. The converter transformers are designed to operate with high harmonic currents and they are designed to withstand AC and DC voltage stress. In most cases converter transformers will have tap changers, which enable optimization of HVDC operation.
- *Smoothing reactors on DC side.* Typical inductance for large HVDC systems is 0.1–0.5 H, which is determined considering DC fault responses, commutation failure and dynamic stability. The reactors are of air-core, natural air-cooling type and costs are modest.
- *Reactive power compensation.* The converters typically require reactive power of around 60% of the converter power rating. A large portion of this reactive power is supplied with filter banks and the remaining part with capacitor banks. Reactive power demand varies with DC power level, so the capacitors are arranged in switchable banks.
- *Filters.* A typical 12-pulse thyristor terminal will require 11th, 13th, 23rd and 25th filters on the AC side. A high-pass filter is frequently included. In some cases third harmonic filters are required. Some HVDC systems with overhead lines also employ DC-side filters.

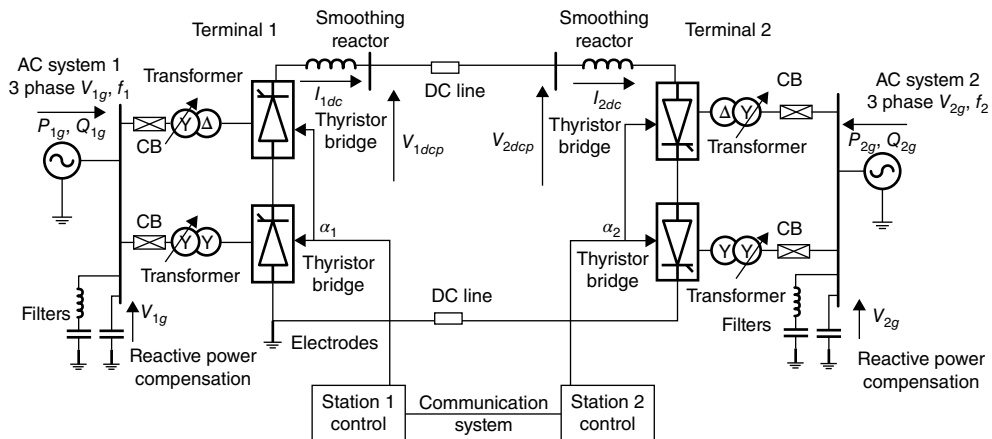

Figure 1.3 Typical HVDC schematic (12-pulse monopole with metallic return).

- *Electrodes.* Some old HVDC systems normally operate with sea/ground return but most grid operators no longer allow permanent ground currents for environmental reasons. Electrodes demand ongoing maintenance costs. Many new bipolar systems are allowed to operate with ground return at half power for a short time (10–20 minutes) in case of loss of an HVDC pole. This implies that electrodes are designed for full current, but carry no current in normal operation.
- *Control and communication system.* Each terminal will have a control system consisting of several hierarchical layers. A dedicated communication link between terminals is needed but speed is not critical. An HVDC link can operate in the event of a loss of a communication link.

1.3 DC Cables and Overhead Lines

1.3.1 Introduction

Line-commutated converter HVDC has been implemented using overhead lines and underground/subsea DC cables. Overhead lines are vulnerable to lightning strikes, which are essentially DC faults. Nevertheless DC faults only cause transient disturbances and they are readily managed by LCC HVDC. On the other hand, with voltage source converter (VSC) HVDC, as will be discussed later, DC faults cause much more serious disturbances.

The most common cable technologies that have been developed so far include:

- mass-impregnated (MI) cables;
- low-pressure oil-filled (LPOF) cables;
- extruded cross-linked polyethylene (XLPE) cables.

The above cable types have same conductors and their construction is similar but the insulation material is substantially different. The cable voltage rating depends on the capability of the insulation (dielectric) material, and there are two main types of dielectrics, namely lapped and extruded.

1.3.2 Mass-impregnated (MI) Cables

Since 1895, MI cables have been used in power transmission. In MI cables, the dielectric is lapped paper insulation, which is impregnated with high-viscosity fluid. For bulk power transmission, mass impregnated cables still prove to be the most suitable solution because of their capacity to work up to 500 kV DC. These cables also tolerate fast DC voltage polarity reversal, making them suitable for LCC HVDC. The MI cables have a long record of field operation at voltages of 500 kV and transmission capacity of over 800 MW (1.6 kA) for monopole HVDC but 600 kV and 1000 MW ratings have been announced. An HVDC with a bipolar connection is therefore able to transmit up to 2000 MW with MI cables. These cables can be installed at depths to 1000 m under the sea level and with nearly unlimited transmission length. The capacity of this system is limited by the conductor temperature, which can reduce overload capabilities. The 580 km-long 700 MW, 450 kV cable link between Norway and the Netherlands represents the greatest power and length for this cable type. At present over 90% of submarine cables are of the MI type.

1.3.3 Low-pressure Oil-filled Cables

Low-pressure oil-filled cables are similar in construction to MI cables but the cables are insulated with paper impregnated with low viscosity oil under an overpressure of a few bars. The technology available today ensures voltages up to 500 kV and powers up to 2800 MW for underground installation. It can be used for both AC and DC transmission applications. As oil flow is required along the cable, cable length is limited to around 80 km. The risk of oil leakage must be taken into account for environmental reasons.

Table 1.1 DC cables types for underground and submarine application.

Type	Mass impregnated	Oil filled	XLPE
Conductor	Cu/Al	Cu/Al	Cu/Al
Insulation	Paper and mass	Paper and fluid	Cross-linked PE
Voltage (kV)	600	500	320 (525 kV is available)
Capacity per cable (MW)	1000	2800	1000
Converter type	LCC or VSC	LCC or VSC	VSC or unidirectional LCC
Distance	Unlimited	Limited because of oil	Unlimited

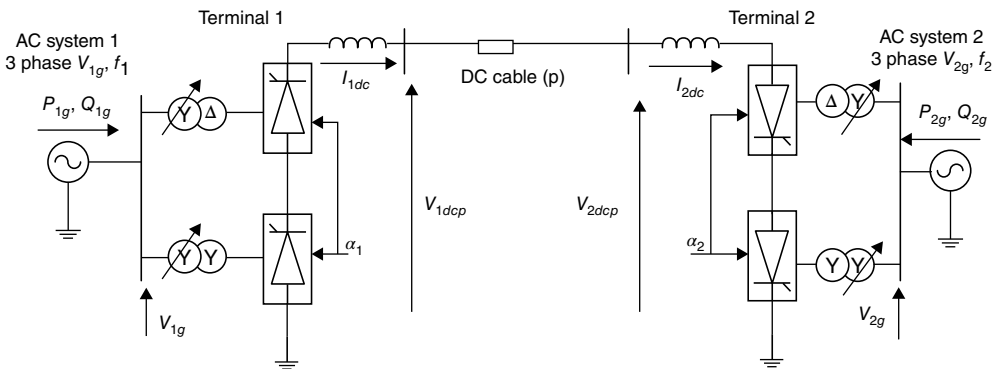
**Figure 1.4** Twelve-pulse monopolar HVDC with ground return.

1.3.4 Extruded Cross-linked Polyethylene (XLPE) Cables

Extruded cross-linked polyethylene cables cannot withstand fast polarity reversal and they are not normally used with LCC HVDC (unless it is a unidirectional system). They will be discussed further with VSC HVDC.

The above three types of cables are used for both underground and submarine cables and their basic properties are shown in Table 1.1. The difference between the underground and submarine cables is in the conductor material and the armour layer. Armour strengthening is used in submarine cables to withstand the axial mechanical tension during laying and operation.

Cables with copper conductors are used for submarine applications whereas aluminium conductors are generally preferred for underground. Copper has high electrical conductivity and mechanical properties. It is also simpler to implement strong joints using copper. However it is heavy and more expensive and for these reasons it is used when the mechanical properties are mandatory, as in submarine cables. Aluminium has low conductivity and low mechanical properties. Splicing is more difficult. It is lighter and less expensive than copper.

1.4 LCC HVDC Topologies

High-voltage direct-current systems are divided into transmission systems and back-to-back HVDC. High-voltage direct-current transmission can be bipolar or monopolar.

Monopolar HVDC is typically used for smaller systems and the topology is shown in Figure 1.4. Typically, positive DC voltage is adopted because of less corona issues. The return current can run through ground or a dedicated cable can be employed. If a return cable is used (metallic return) it will

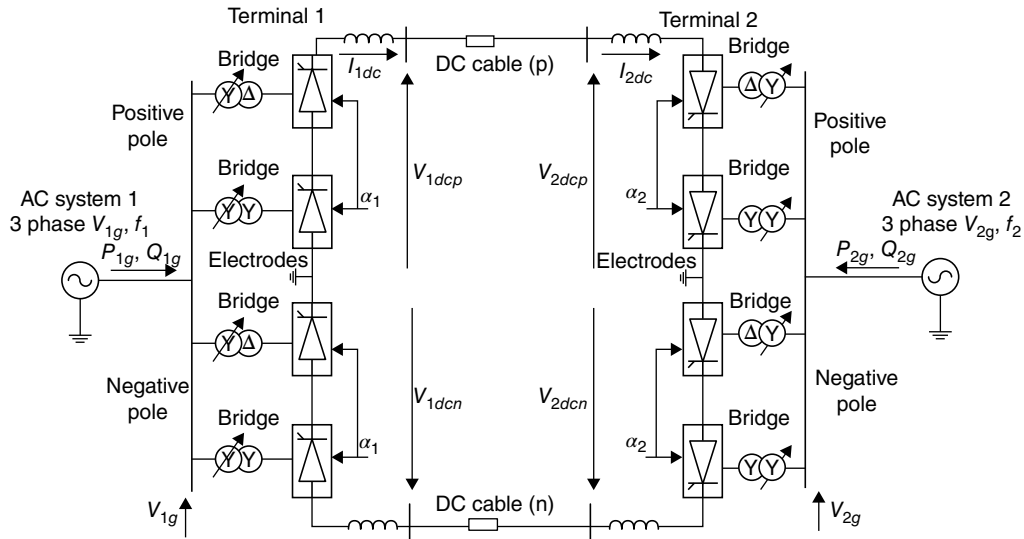

Figure 1.5 Bipolar HVDC (12-pulse) with ground return.

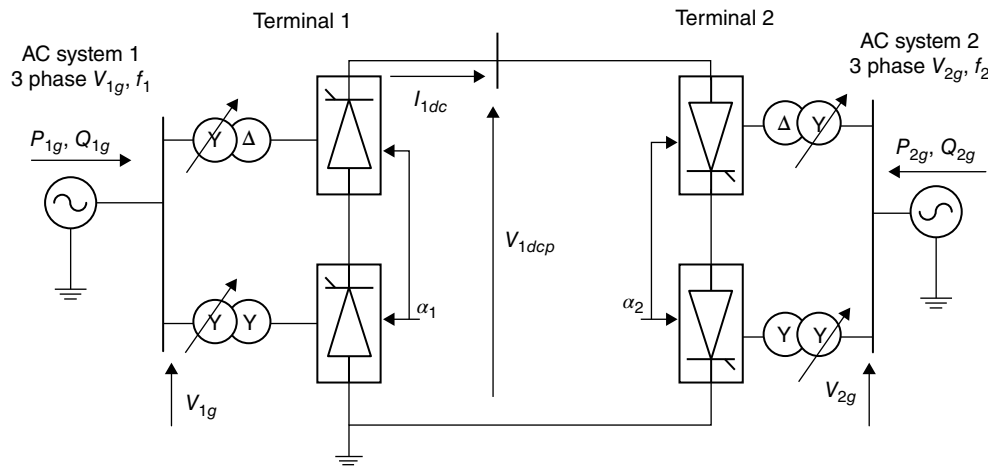

Figure 1.6 Back-to-back HVDC topology.

be at ground potential with low insulation level (typically around 10 kV) and costs are therefore lower than positive-pole DC cable. A 12-pulse topology is shown with two six-pulse converters in series.

Figure 1.5 shows a bipolar HVDC. Bipolar HVDC has two independent poles and it can operate at half power if one DC cable or pole is out of service. Normally the poles are balanced and there is no ground current but ground return would be used if one pole is out of service. In modern grid codes, ground current would not be allowed because of environmental concerns. In some national standards ground currents are allowed only for short periods of time in emergency situations (e.g. secondary reserve startup for 10–20 minutes). Instead of ground return a third cable or DC cable from the faulted pole can sometimes be used.

Figure 1.6 shows a back-to-back HVDC, which is frequently monopolar. In this topology both converter terminals are located in a single station and DC cables are very short. The main purpose of back-to-back HVDC is to provide controllable power transfer between two asynchronous AC

systems or AC systems with different frequency. As DC cables are very short and therefore transmission losses are low, back-to-back HVDC are designed at low voltage (as high current as possible) in order to reduce costs (costs are proportional to insulation level). The smoothing reactors are very small or not required because there is a low probability of DC line faults. Back-to-back HVDC allows for operation with variable DC voltage and this facilitates some limited reactive power control capability.

1.5 Losses in LCC HVDC Systems

The losses in HVDC systems will include converter station losses and DC cable losses. Figure 1.7 shows the main components of typical HVDC station losses. The total LCC HVDC station losses will depend on the size of HVDC station, the voltage level, configuration and typically may amount to 0.5–1% of the power transfer.

At partial loading the percentage losses will generally increase. Figure 1.8 shows the load dependence of major loss components. As an example, magnetizing current in converter transformers will be constant irrespective of loading and at 10% loading the transformer losses are 20%.

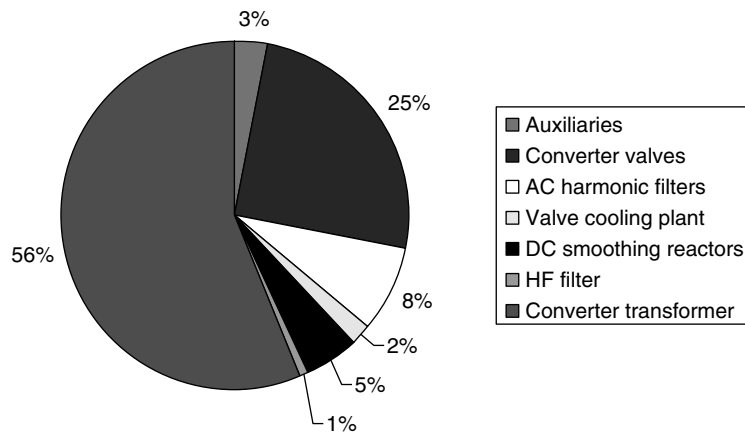

Figure 1.7 Breakdown of typical LCC HVDC station losses at 1 pu power.

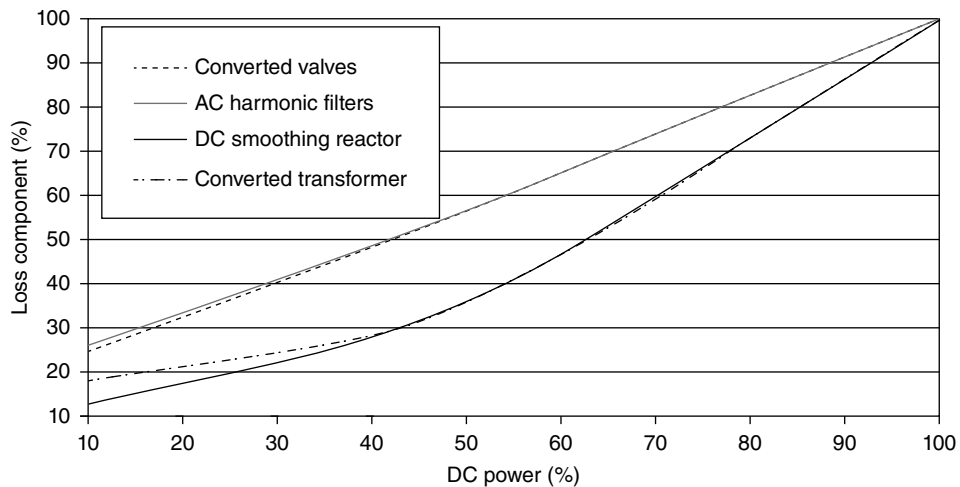

Figure 1.8 Variation of HVDC station losses with the DC power, shown relative to 1 pu losses.

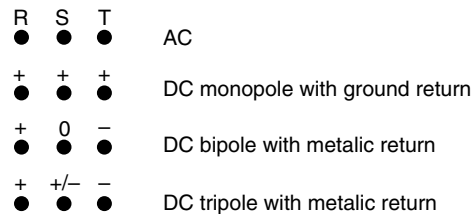

Figure 1.9 Options for conversion of three-phase AC lines into DC.

1.6 Conversion of AC Lines to DC

There have been many studies worldwide on converting existing AC lines into DC. This mainly results from the desire to increase AC line capacity or to remove stability constraints. These issues usually require costly line upgrades/reconductoring, series compensation or installing a device from the flexible AC transmission systems (FACTS) family. In such cases, conversion to HVDC can usually offer the highest capacity increase and a range of other benefits. Typically towers and conductors will not be changed but insulators may need to be upgraded to operate with DC lines.

The main advantages of converting existing AC line to HVDC are:

- an increase in capacity;
- fewer corona issues and a generally higher operating voltage;
- better control of active and reactive power and other system-level benefits;
- better stability limits and active stabilization of the grid;
- lower transmission losses.

Some of the disadvantages of conversion to HVDC include:

- more pollution is attracted to insulators energized with DC – insulator upgrade is recommended;
- converter station costs.

Figure 1.9 shows some common options for converting a single-circuit three-phase AC transmission into DC which include:

- The first option employs all three conductors for a single DC pole while the ground is used for return. This method will significantly increase current carrying capacity but ground return will not be allowed in many modern systems.
- The second option adopts DC bipole with metallic return. The neutral conductor can be used for monopolar operation.
- The third option is based on the tripole HVDC concept. This method uses the third conductor alternatively as a positive or negative pole, which exploits the long thermal constants of conductors. The capacity increase of around 37% is achieved (over bipole configuration) using lines and the RMS values of current in the conductors (over 10 minutes) are equal to the conductor rating. An additional bidirectional converter is required.

1.7 Ultra-High Voltage HVDC

The standard DC voltage for HVDC is 500 kV and the Itaipu 3150 MW, ± 600 kV HVDC has used the highest DC voltage for a long period. However the emerging requirements for bulk power transmission

over long distances of 5–10 GW in Asia, Africa and South America in late 1990s have resulted in the progressive development of UHVDC (ultra-high voltage direct current).

Xiangjiaba–Shanghai 6400 MW, ± 800 kV UHVDC, implemented in 2010, was the first commercial UHVDC, and four other ± 800 kV systems have been implemented in 2011–2013, while studies are underway for 1100 kV DC voltages. The progress towards UHVDC has demanded a lot of research and development effort and the main challenges are summarized below:

- improving insulation, in particular in polluted areas;
- transformer development, including bushings;
- developing ultra-high voltage (UHV) test centres.

It is important to appreciate that all the equipment, including auxiliaries that connect to DC lines, must be changed to UHV. In practice this translates to longer units – bushings, arresters, VT (voltage transducers), CT (current transducers), and so forth – with more series-connected basic elements. Frequently, the main challenge is the need for mechanical strength in the face of increased forces from seismic requirements, wind and other factors.

The use of new insulating materials and corona shields becomes a standard method of increasing insulation levels, although developing UHV insulators and bushings remains challenging.

The UHV valve design is not considered to be a significant obstacle.