

Interior Space

COPYRIGHTED MATERIAL

Space is a prime ingredient in the designer's palette and the quintessential element in interior design. Through the volume of space we not only move; we see forms, hear sounds, feel gentle breezes and the warmth of the sun, and smell the fragrances of flowers in bloom. Space inherits the sensual and aesthetic characteristics of the elements in its field.

Space is not a material substance like stone and wood. It is inherently formless and diffuse. Universal space has no defining borders. Once an element is placed in its field, however, a visual relationship is established. As other elements are introduced into the field, multiple relationships are established between the space and the elements, as well as among the elements themselves. Space is formed by our perception of these relationships.

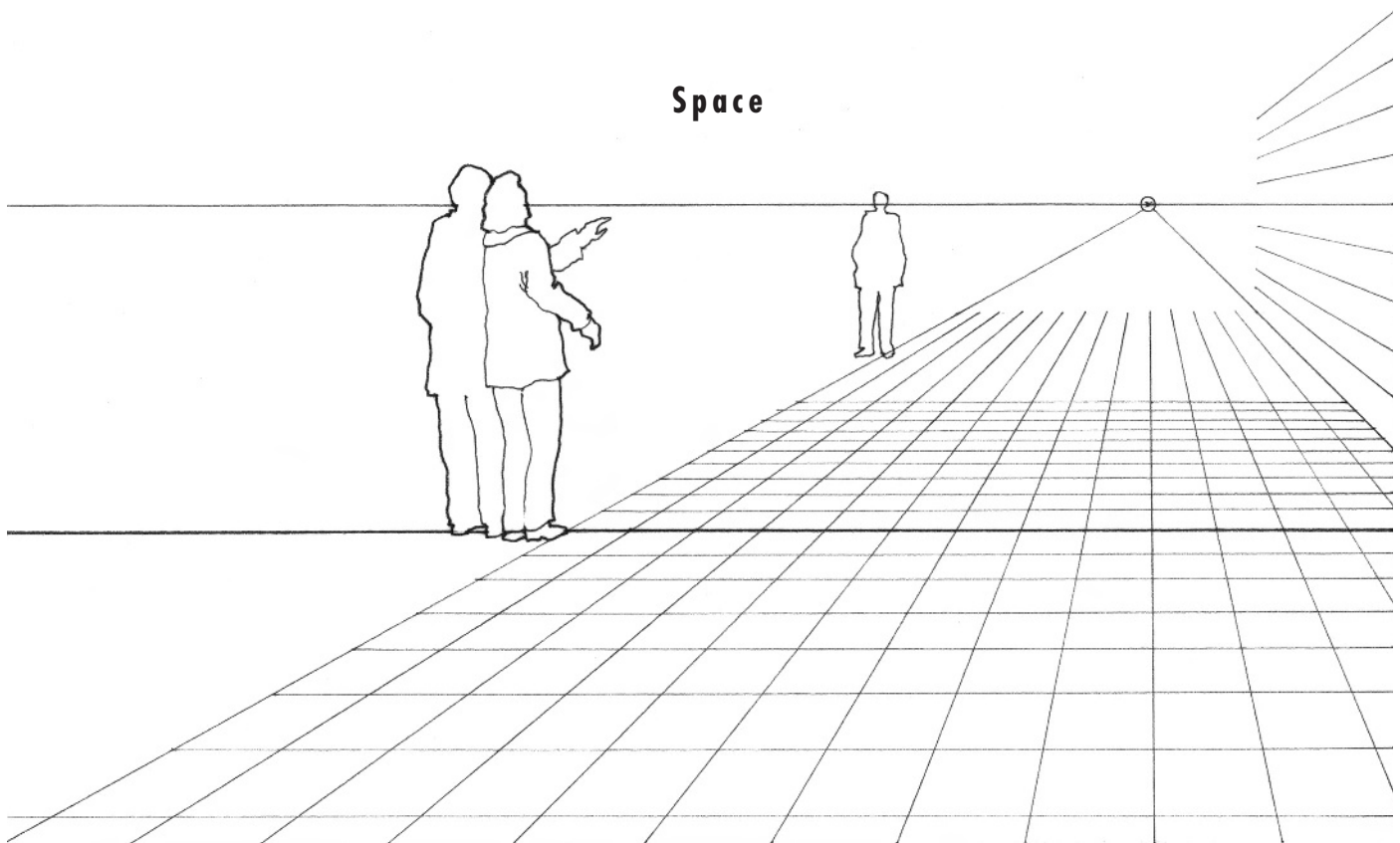

The geometric elements—point, line, plane, and volume—can be arranged to articulate and define space. In architecture, these fundamental elements become linear columns and beams, planar walls, floors, and roofs.

- A column marks a point in space and makes it visible in three dimensions.
- Two columns define a spatial membrane through which we can pass.
- When supporting a beam, the columns delineate the edges of a transparent plane.
- A wall, an opaque plane, marks off a portion of amorphous space and separates here from there.
- A floor defines a field of space with territorial boundaries.
- A roof provides shelter for the volume of space beneath it.

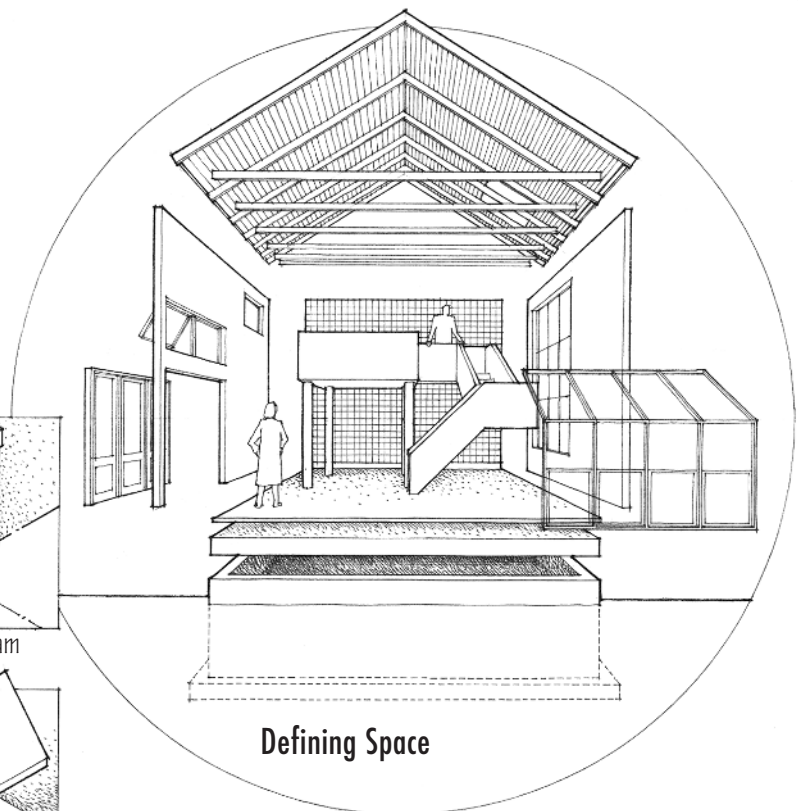
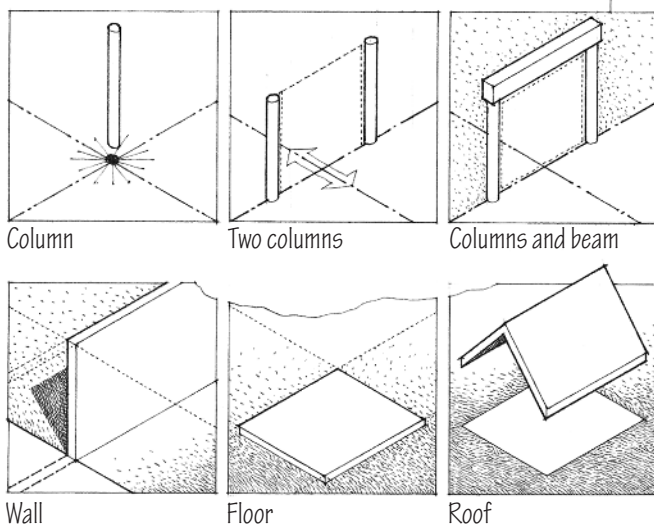

Defining Space

In architectural design, these elements are organized to give a building form, differentiate between inside and outside, and define the boundaries of interior space.

EXTERIOR SPACE

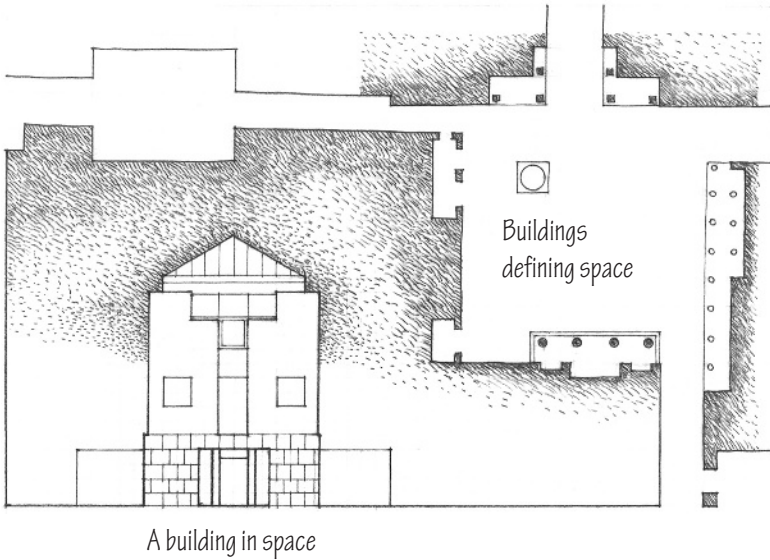

A building's form, scale, and spatial organization are the designer's response to a number of conditions—functional planning requirements, technical aspects of structure and construction, economic realities, and expressive qualities of image and style. In addition, the architecture of a building should address the physical context of its site and the exterior space.

A building can be related to its site in several ways. It can merge with its setting or dominate it. It can surround and capture a portion of exterior space. One of its faces can be made to address a feature of its site or define an edge of exterior space. In each case, due consideration should be given to the potential relationship between interior and exterior space, as defined by the nature of a building's exterior walls.

Buildings affect and are affected by conditions of their sites and the wider environment. Selecting and developing sites to reduce site disturbance, stormwater runoff, heat island effects, and light pollution contribute to sustainable design.

Buildings

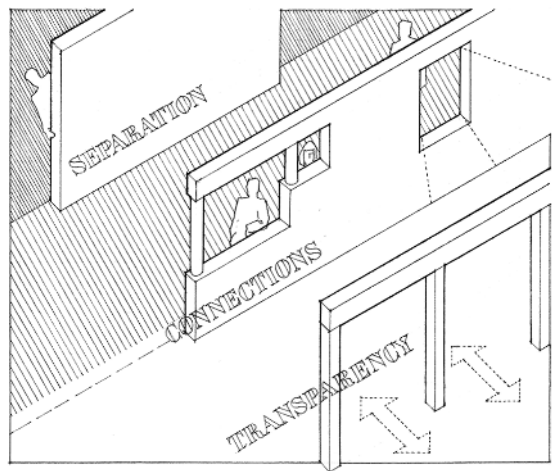
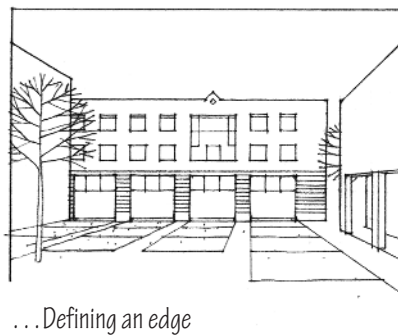
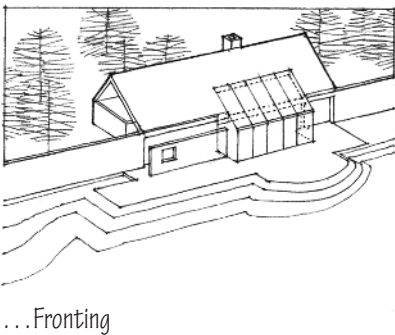
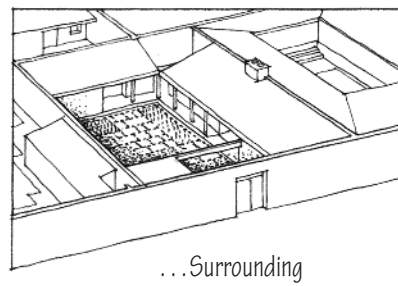
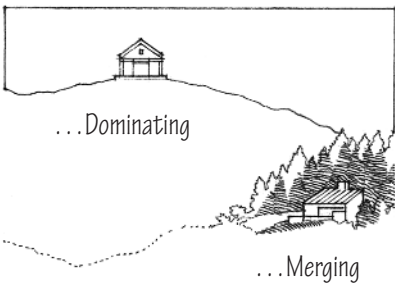

Exterior Walls

A building's exterior walls constitute the interface between our interior and exterior environments. In defining both interior and exterior space, they determine the character of each. They may be thick and heavy, expressing a clear distinction between a controlled interior environment and the exterior space from which it is isolated. They may be thin, or even transparent, and attempt to merge inside and outside.

Windows and doorways, the openings that penetrate a building's exterior walls, are the spatial transitions between exterior and interior space. Their scale, character, and composition often tell us something about the nature of the interior spaces that lie between them.

Special transitional spaces, belonging to both the outside world and the inside, can be used to mediate between the two environments. Familiar examples include a porch, a veranda, or an arcaded gallery.

Many single-family residences have steps at all entrances that present barriers to people with physical disabilities. *Visitability* is a movement to construct new homes so that they can be readily lived in and visited by people with mobility impairments.

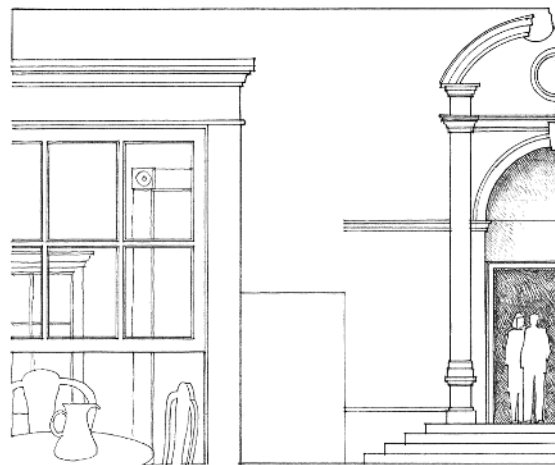
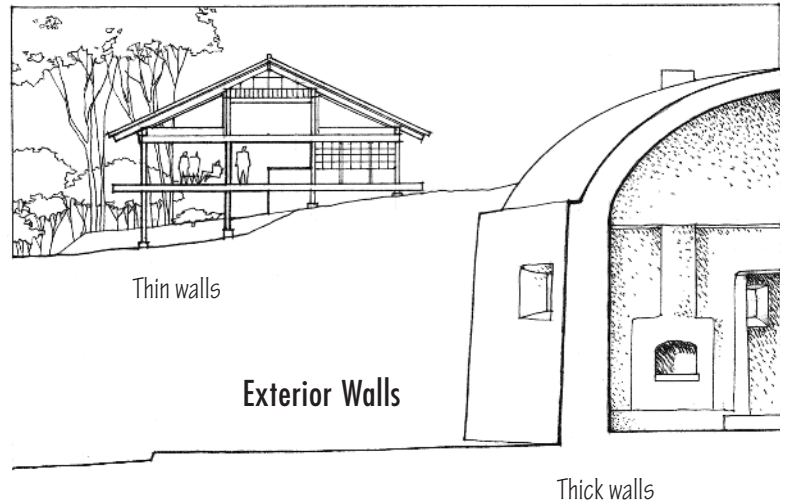

Spatial Transitions

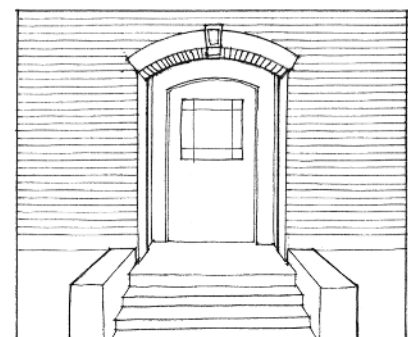
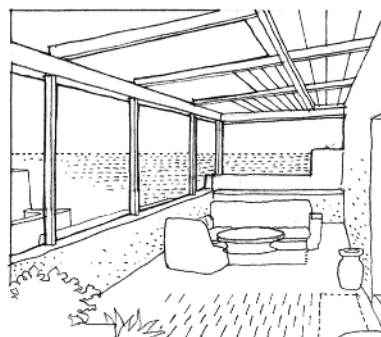
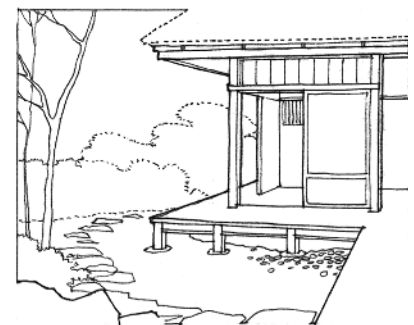
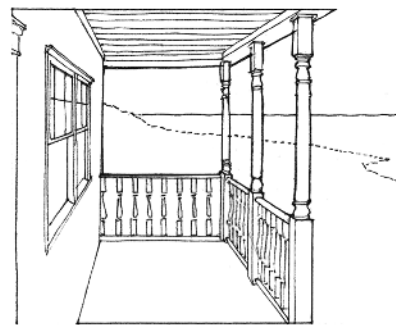

INTERIOR SPACE

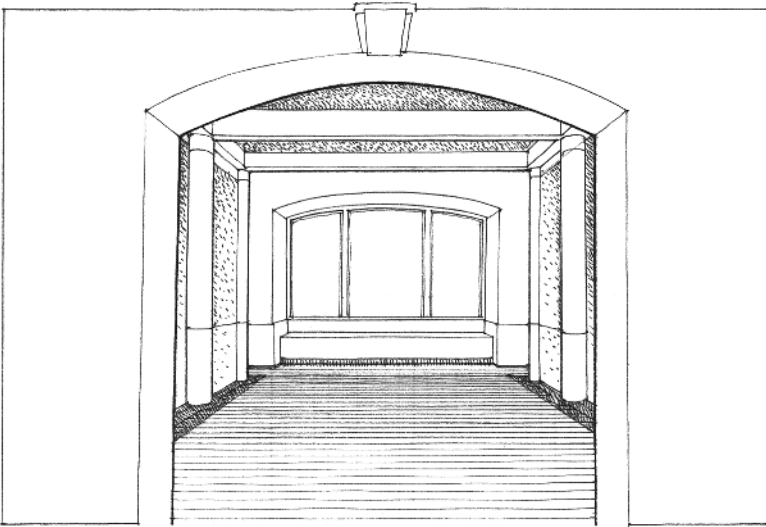

Entrances mark the transition from here to there.

Upon entering a building, we sense shelter and enclosure. This perception is due to the bounding floor, wall, and ceiling planes of interior space. These are the architectural elements that define the physical limits of rooms. They enclose space, articulate its boundaries, and separate it from adjoining interior spaces and the outside.

Floors, walls, and ceilings do more than mark off a simple quantity of space. Their form, configuration, and pattern of window and door openings also imbue the defined space with certain spatial or architectural qualities. We use terms such as grand hall, loft space, sun room, and alcove not simply to describe how large or small a space is, but also to characterize its scale and proportion, its quality of light, the nature of its enclosing surfaces, and the way it relates to adjacent spaces.

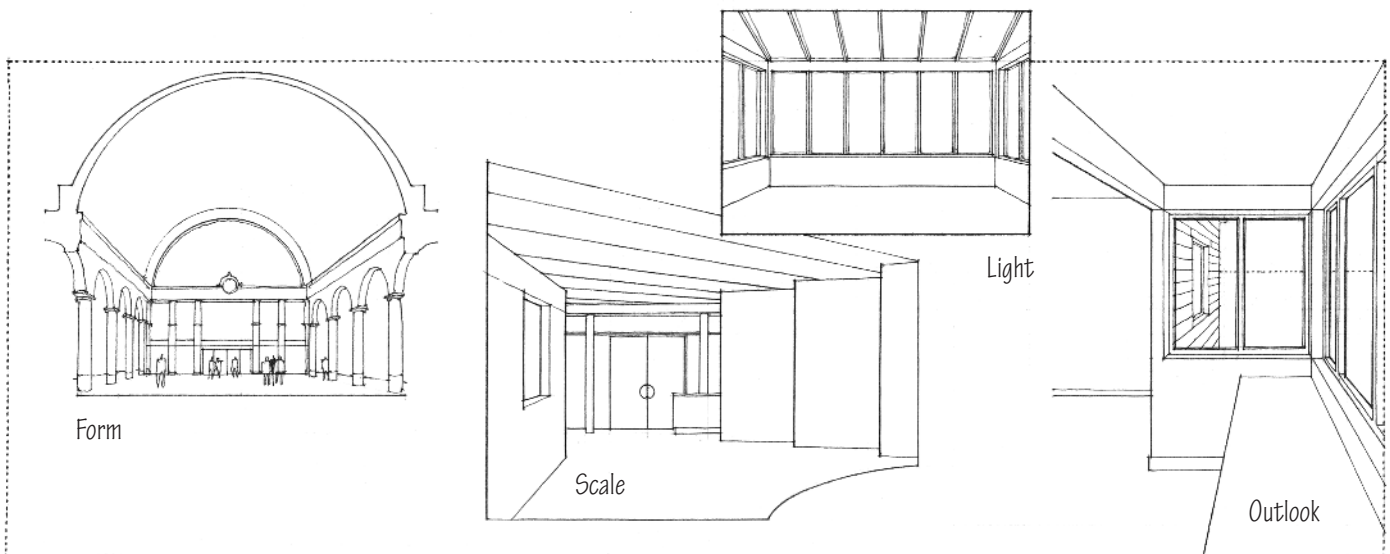

Spatial Qualities

Interior design necessarily goes beyond the architectural definition of space. In planning the layout, furnishing, and enrichment of a space, the interior designer should be acutely aware of its architectural character as well as its potential for modification and enhancement. The design of interior spaces requires, therefore, an understanding of how they are formed by the building systems of *structure* and *enclosure*. With this understanding, the interior designer can effectively elect to work with, continue, or even offer a counterpoint to the essential qualities of an architectural space.

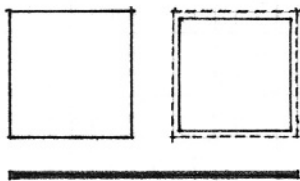
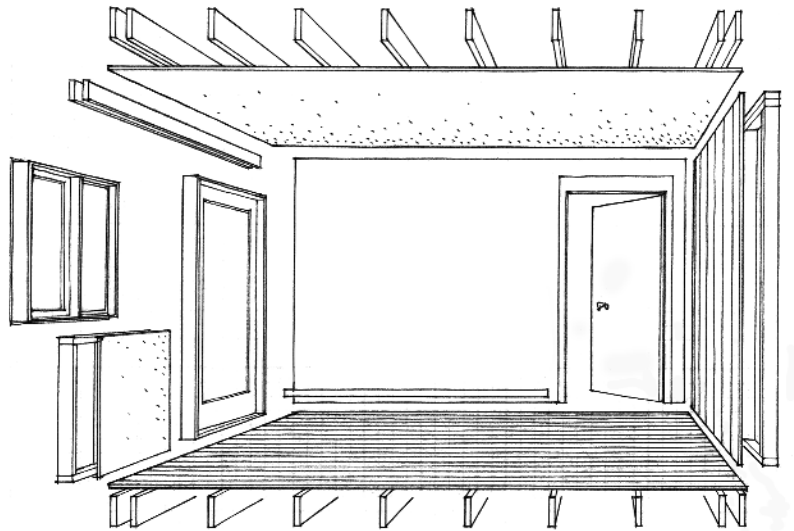

Continuation

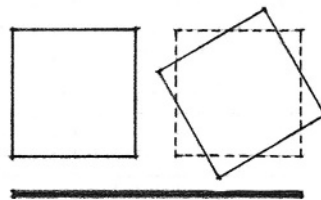

Contrast

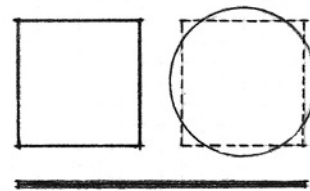

Counterpoint

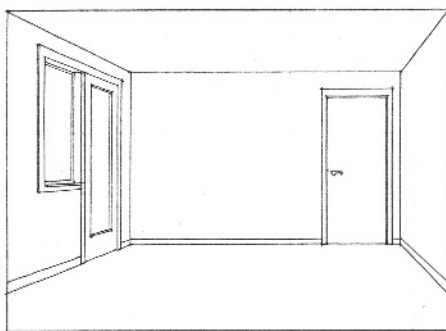

The basic shell

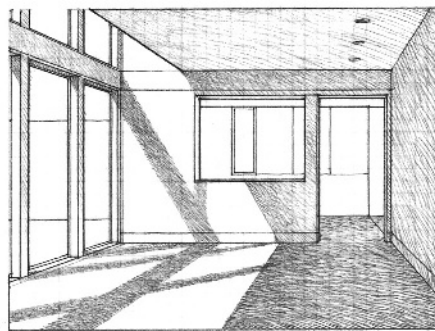

... modified architecturally

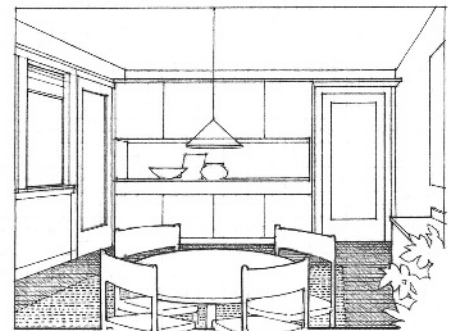

... or through interior design

Interior Space

Buildings typically consist of physical systems of structure, enclosure, and building services equipment.

Structural Systems

- The *superstructure* is the vertical extension of the foundation system and consists of the columns, beams, and load-bearing walls that support the floor and roof structures.
- The *foundation system* is the substructure that forms the base of a building, anchors it firmly to the ground, and supports the building elements and spaces above.

These systems must work together to support the following types of loads:

Dead Loads: How a building is constructed determines its *dead load*, which is a static vertical load comprising the weight of its structural and nonstructural components, including any equipment permanently attached to the structure.

Live Loads: How a building is used determines its *live load*, which is a movable or moving load comprising the weight of its occupants and any mobile equipment and furnishings. In cold or wet climates, collected snow and water impose an additional live load on a building.

Dynamic Loads: Where a building is located determines its potential to bear a *dynamic load*, which can change suddenly due to the forces of wind and earthquakes.

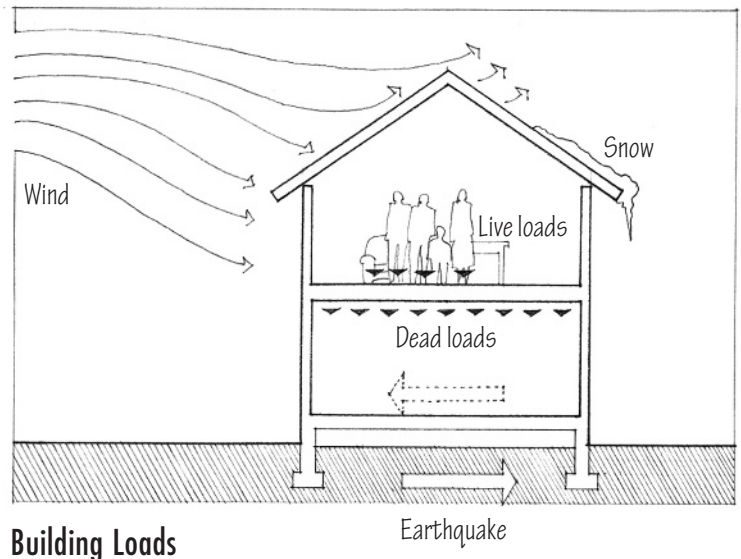
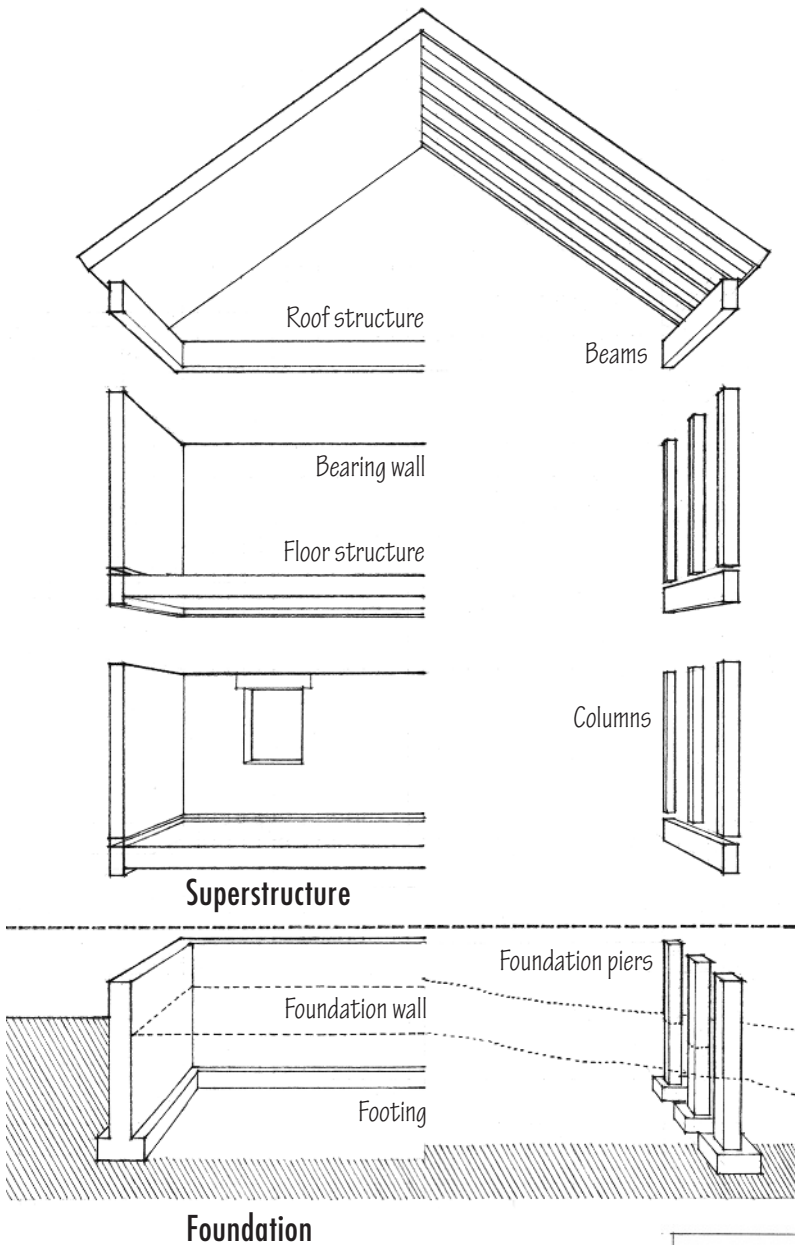

Enclosure System

- The *building envelope* consists of exterior walls, windows, doors, and roof, which protect and shelter interior spaces from the exterior environment.
- Interior walls, partitions, and ceilings subdivide and define interior space. Many of these components are nonstructural in nature and carry no loads other than their own weight.

Building Services

- Mechanical systems provide essential services to a building, such as the heating, ventilation, and air-conditioning of interior spaces.
- Plumbing systems supply water suitable for human consumption and firefighting, and dispose of sanitary waste.
- Electrical systems control and safely distribute power for lighting, equipment, security, communication, and vertical transportation.

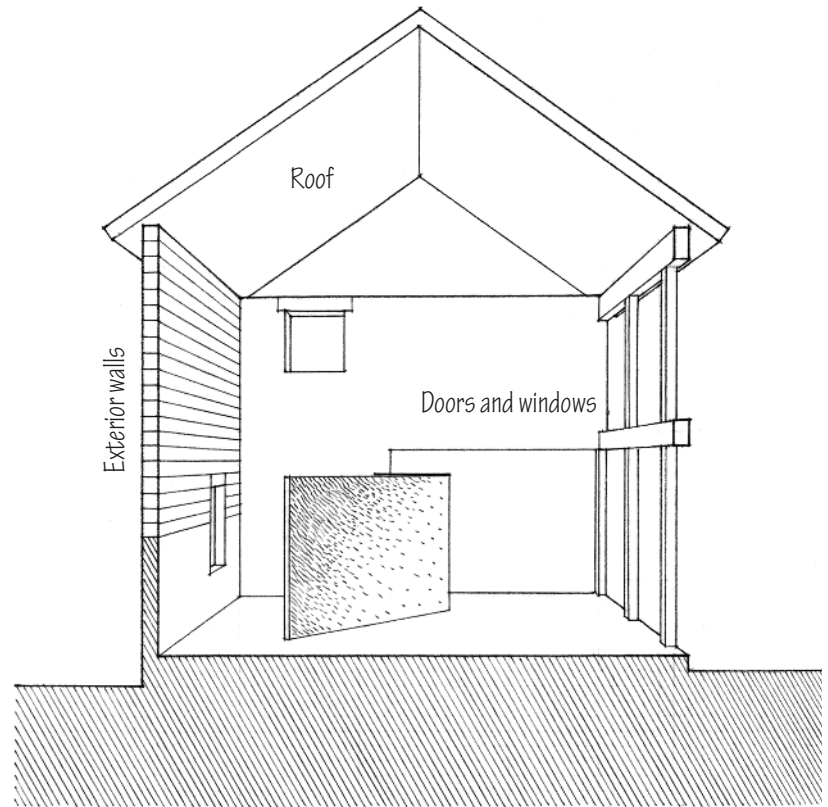

Building Envelope

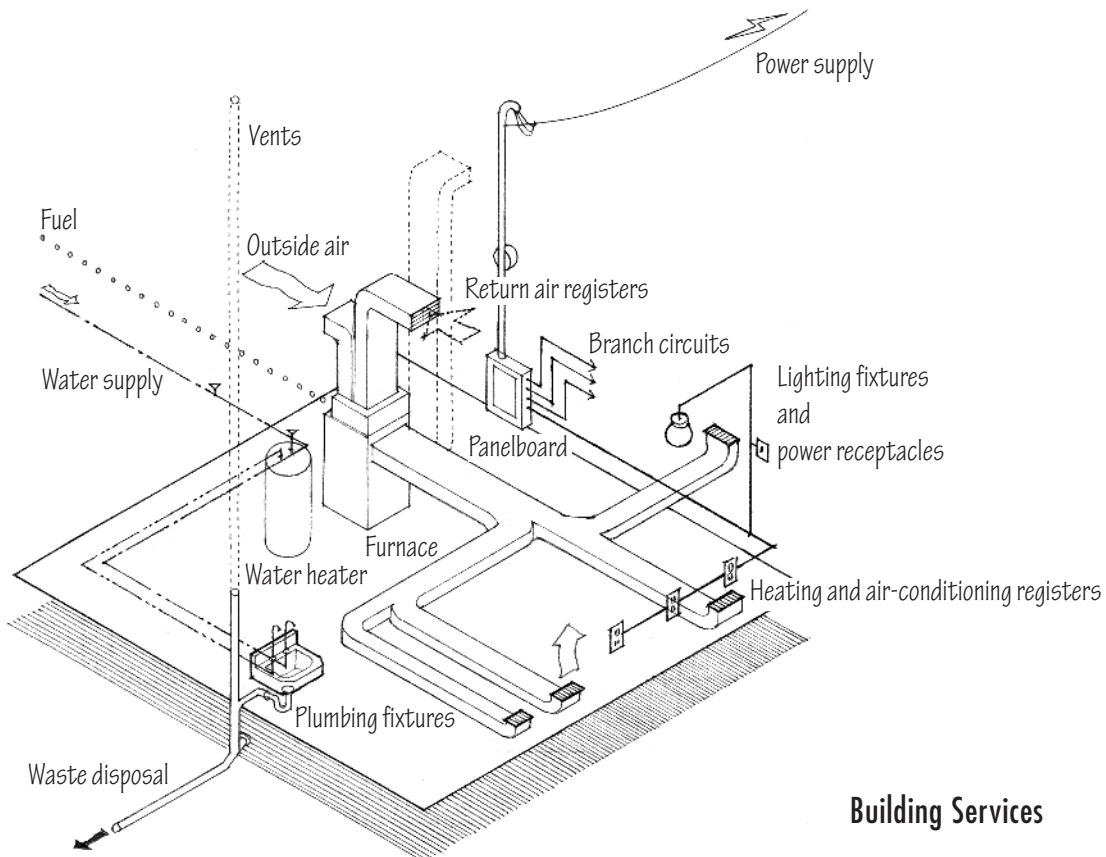

Building Services

STRUCTURAL SYSTEMS

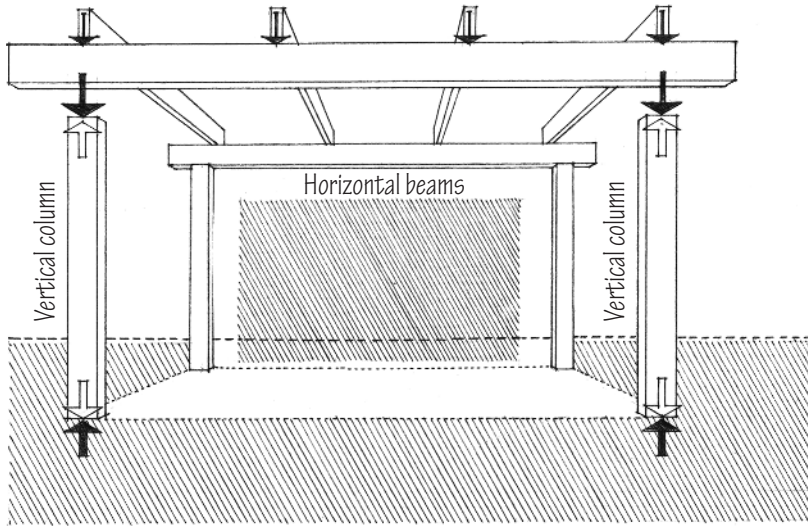

A building's structural system is formed according to the geometry of its materials and the way they react to the forces applied to them. This structural form and geometry, in turn, influence the dimensions, proportion, and arrangement of the interior spaces within the building volume.

The two basic linear structural elements are the column and the beam. A *column* is a vertical support that transmits compressive forces downward along its shaft. The thicker a column is in relation to its height, the greater its load-bearing capacity and its ability to resist buckling resulting from off-center loading or *lateral forces*.

A *beam* is a horizontal member that transmits forces perpendicular to itself along its length to its supports. A beam is subject to bending and deflection, which result in an internal combination of compressive and tensile stresses. These stresses are proportionally greater along the upper and lower region of a beam's cross section. Increasing depth and placing material where stresses are greatest optimize a beam's performance.

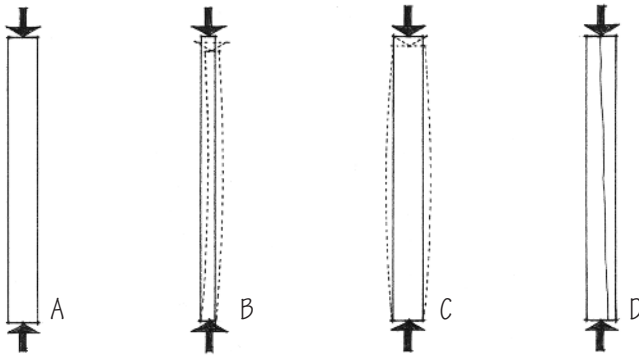

- A. Columns are subject to compression.
- B. Slender columns are subject to buckling.
- C. Thick columns may compress, or
- D. In the case of timber or concrete, they may split or fracture.

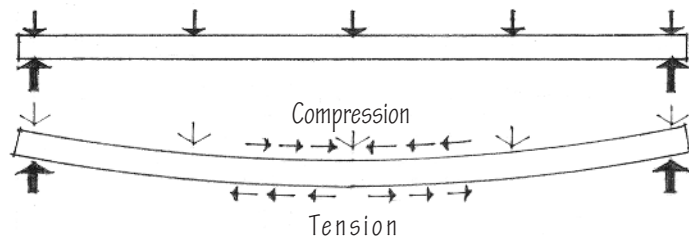

Beams are subject to bending.

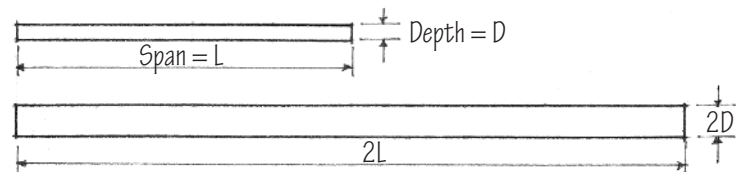

Increasing a beam's depth enables it to span greater distances.

Columns mark points in space and provide a measure for its horizontal divisions. Beams make structural and visual connections across space between their supports. Together, columns and beams form a skeletal framework around interconnected volumes of space.

A linear structural system may suggest a grid layout of repetitive spaces, but floor, wall, and ceiling planes are necessary for the support and enclosure of interior space. Floor and ceiling planes, which define the vertical limits of space, may consist of planar *slabs* or a hierarchical arrangement of *girders* (large primary beams) and beams and *joists* (a series of smaller, parallel beams). Walls and partitions need not be load-bearing and do not have to be aligned with the columns of a structural frame, except where serving as *shear walls* and providing for lateral stability. They are free to define the horizontal dimensions of space according to need, desire, or circumstance.

Linear structural systems are cumulative by nature and eminently flexible. They allow for growth, change, and the adaptation of individual spaces to their specific uses.

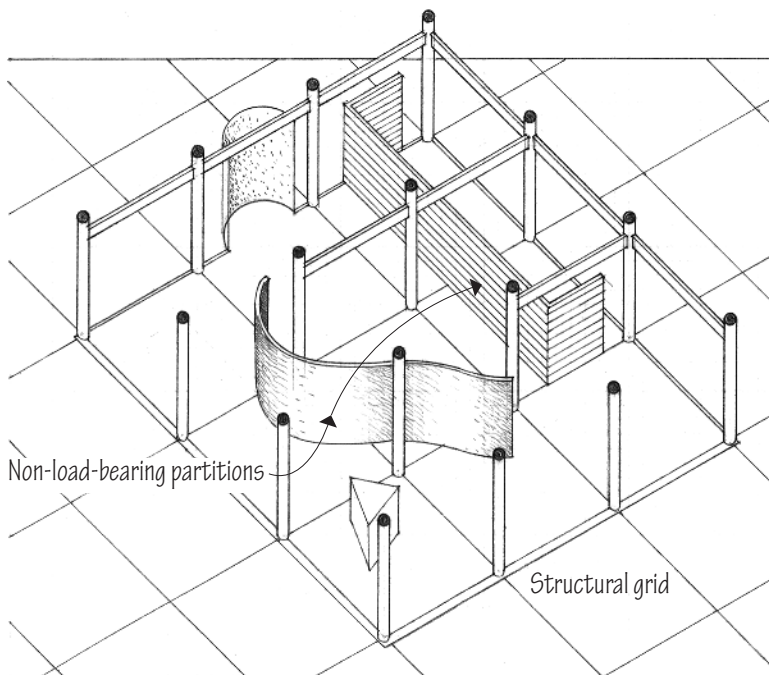
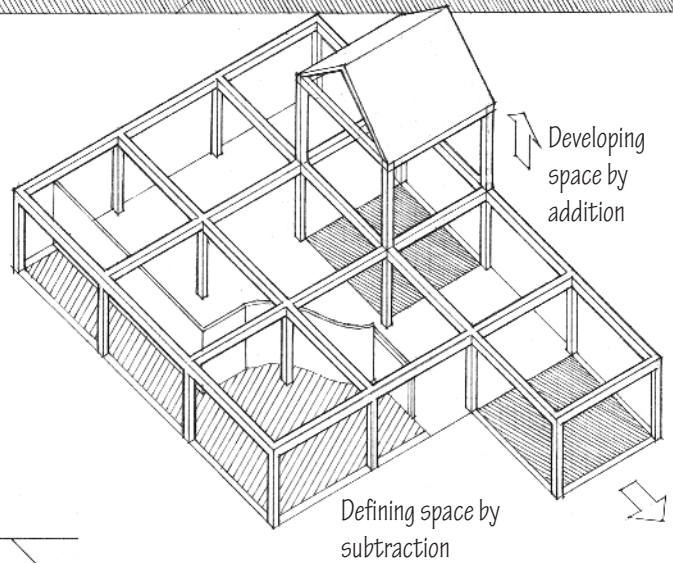
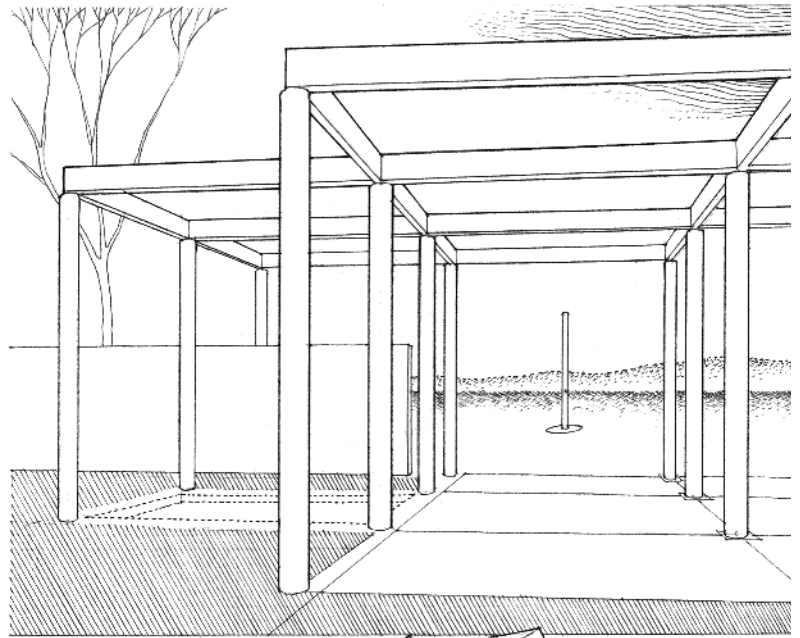

PLANAR STRUCTURAL SYSTEMS

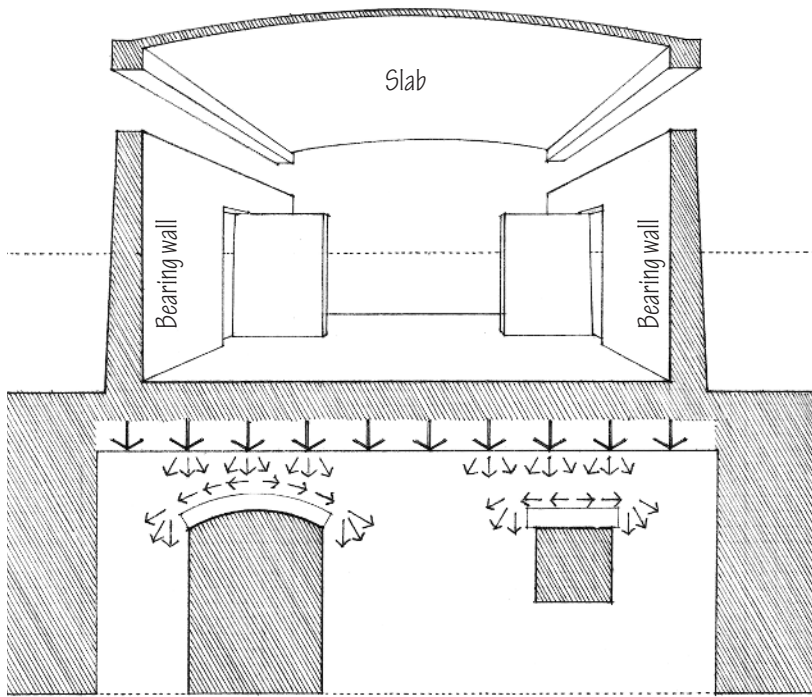

Small beams or lintels are required to span openings in bearing walls.

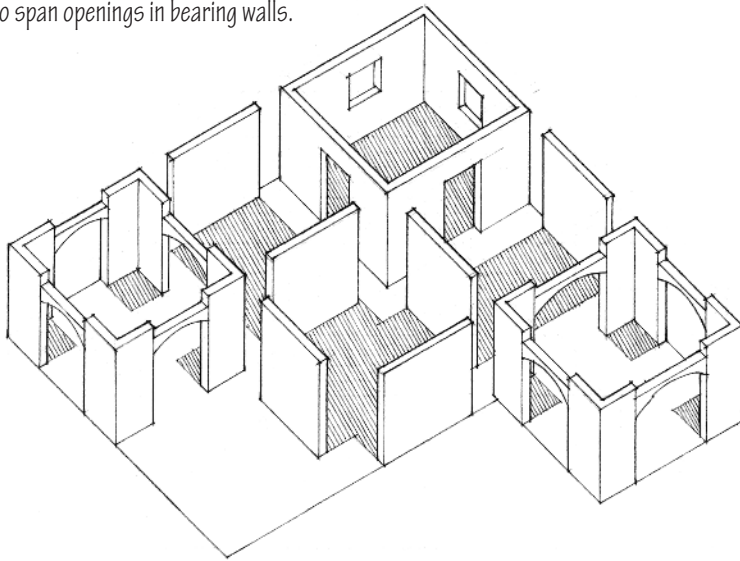

Varying degrees of spatial enclosure are possible with walls, depending on the size and location of openings within their planes.

The two principal types of planar structural elements are the *load-bearing wall* and the horizontal slab. A bearing wall acts as a long, thin column in transmitting compressive forces to its support or foundation.

Window and door openings within a bearing wall tend to weaken its structural integrity. Any opening must be spanned by an arch or a short beam called a *lintel* to support the wall load above and allow compressive stresses to flow around the opening to adjacent sections of the wall.

A common pattern for bearing walls is a parallel layout spanned by floor joists and roof rafters, or by horizontal slabs. For lateral stability, *pilasters* and cross walls are often used to help brace bearing walls.

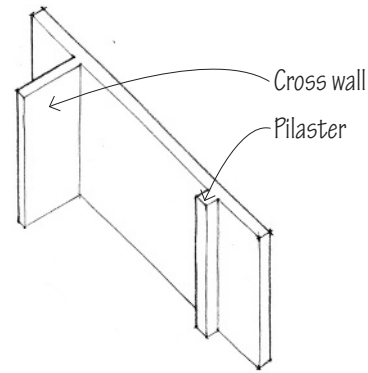

While linear structural elements outline the edges of spatial volumes, planar elements such as bearing walls define the physical limits of space. They provide a real sense of enclosure and privacy as well as serve as barriers against the elements.

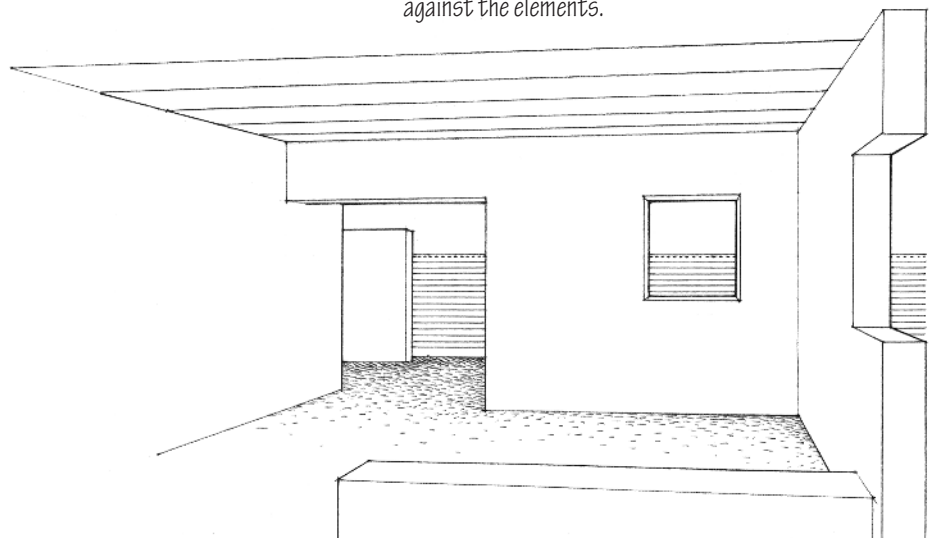

A slab is a horizontal, rigid, usually monolithic plate. A common example is a reinforced concrete slab. A slab is able to support both concentrated and distributed loads because the resulting stresses can fan out across the plane of the slab and take various paths to the slab supports.

When supported along two edges, a slab can be considered a wide, shallow beam extending in one direction. Supported along four sides, a slab becomes a two-way structural element. For greater efficiency and reduced weight, a slab can be modified in sections to incorporate ribs.

When integrally connected with reinforced concrete columns, flat slabs can be supported without beams. They form horizontal layers of space punctuated only by the shafts of the supporting columns.

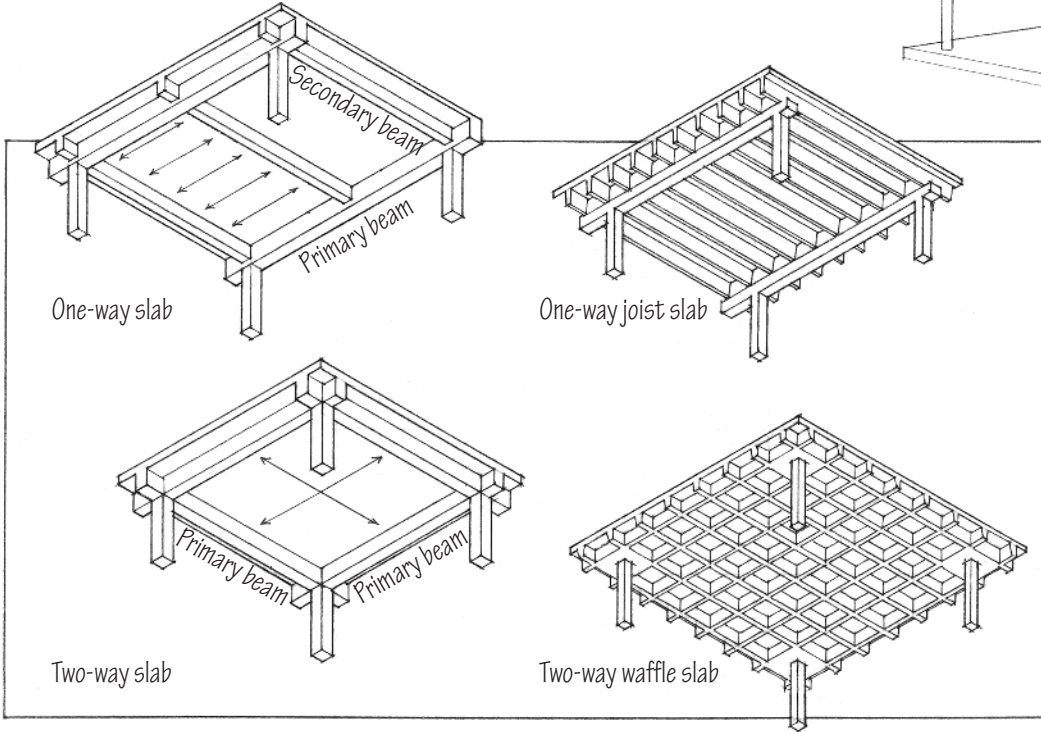
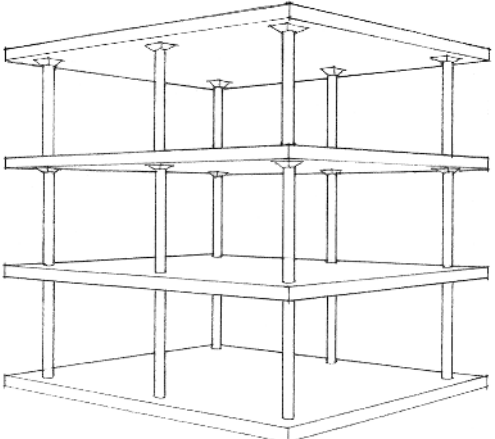
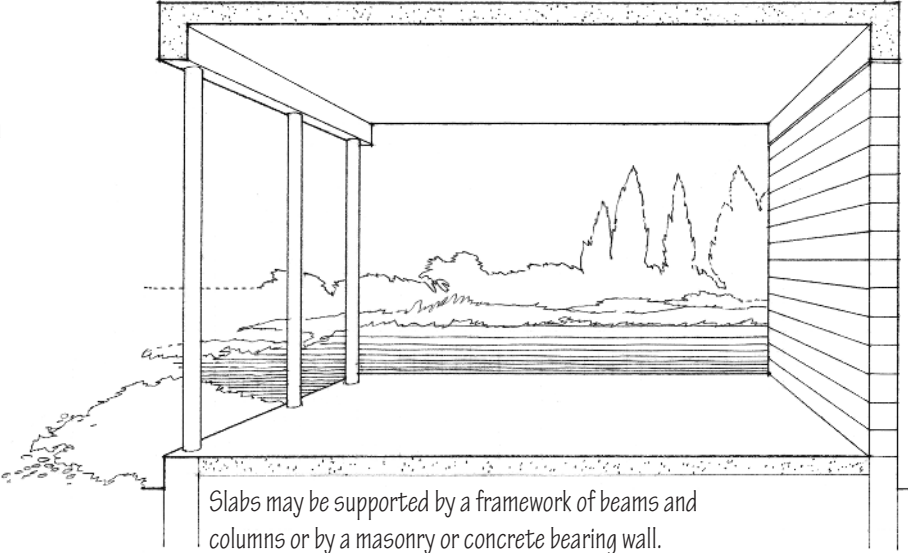

Two-way flat slabs thickened at their column supports define horizontal layers of space.

Types of Slabs

VOLUMETRIC STRUCTURAL SYSTEMS

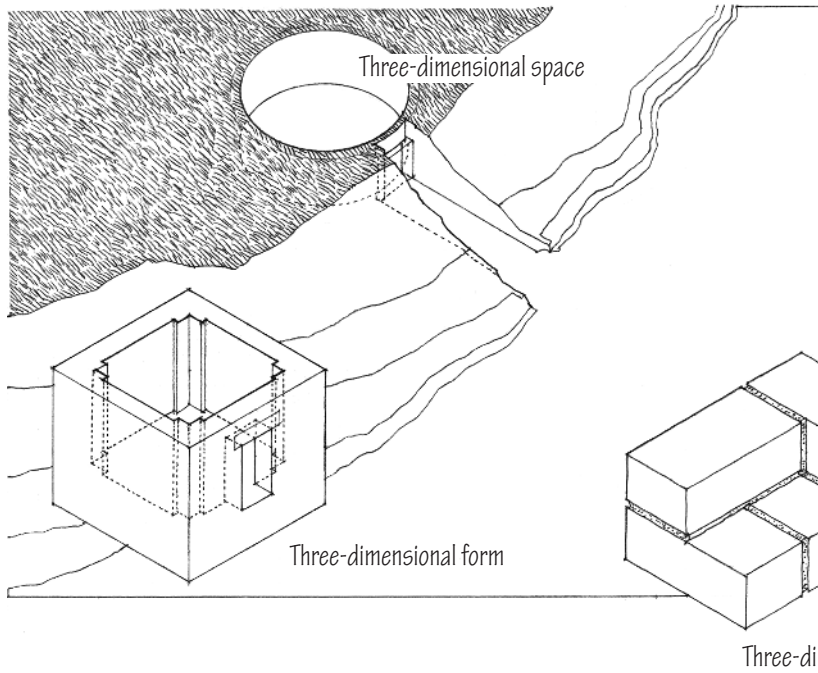

A volumetric structural system consists of a three-dimensional mass. The mass of the material occupies the void of space. The volume of interior space is carved out of the mass. The efficiency of engineering methods and the strength of modern building materials have limited the use of pure volumetric structural systems, although three-dimensional computer design is changing this; an example is the Walt Disney Concert Hall designed by Frank Gehry. At a small scale, stone and clay masonry units can be seen to be volumetric structural elements. At a larger scale, any building that encloses interior space can be viewed as a three-dimensional structure that must have strength in width, length, and depth.

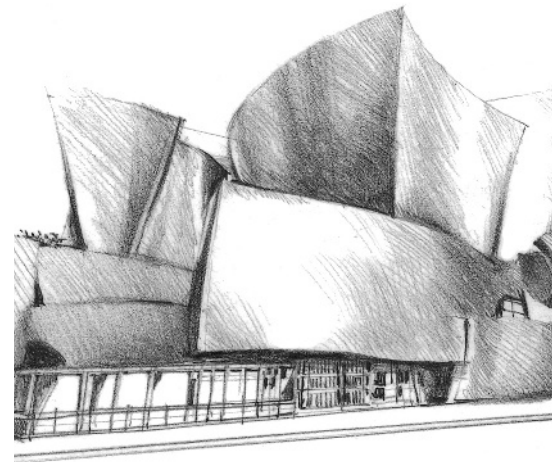
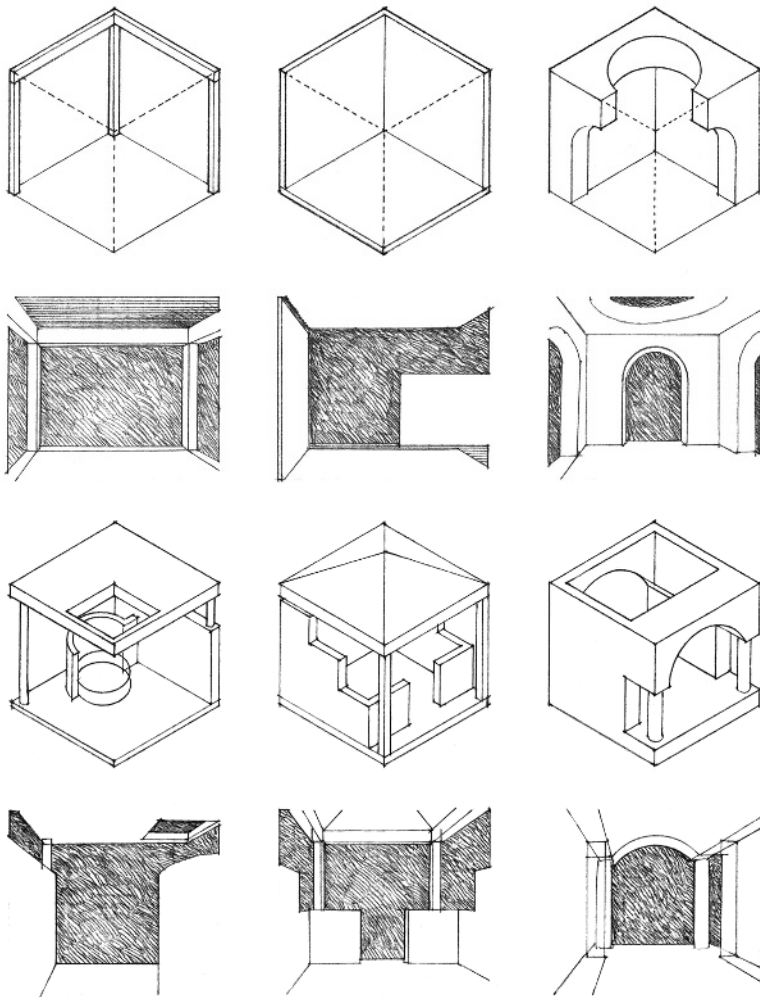

Walt Disney Concert Hall, Los Angeles, California, Frank Gehry, 2003

Composite systems combine linear, planar, and volumetric elements into three-dimensional compositions of form and space.

Most structural systems are in fact composites of linear, planar, and volumetric elements. No one system is superior to all others in all situations. For the structural designer, each presents advantages and disadvantages, depending on the size, location, and intended use of a building. An interior designer should be aware of the character of the interior spaces each system defines.

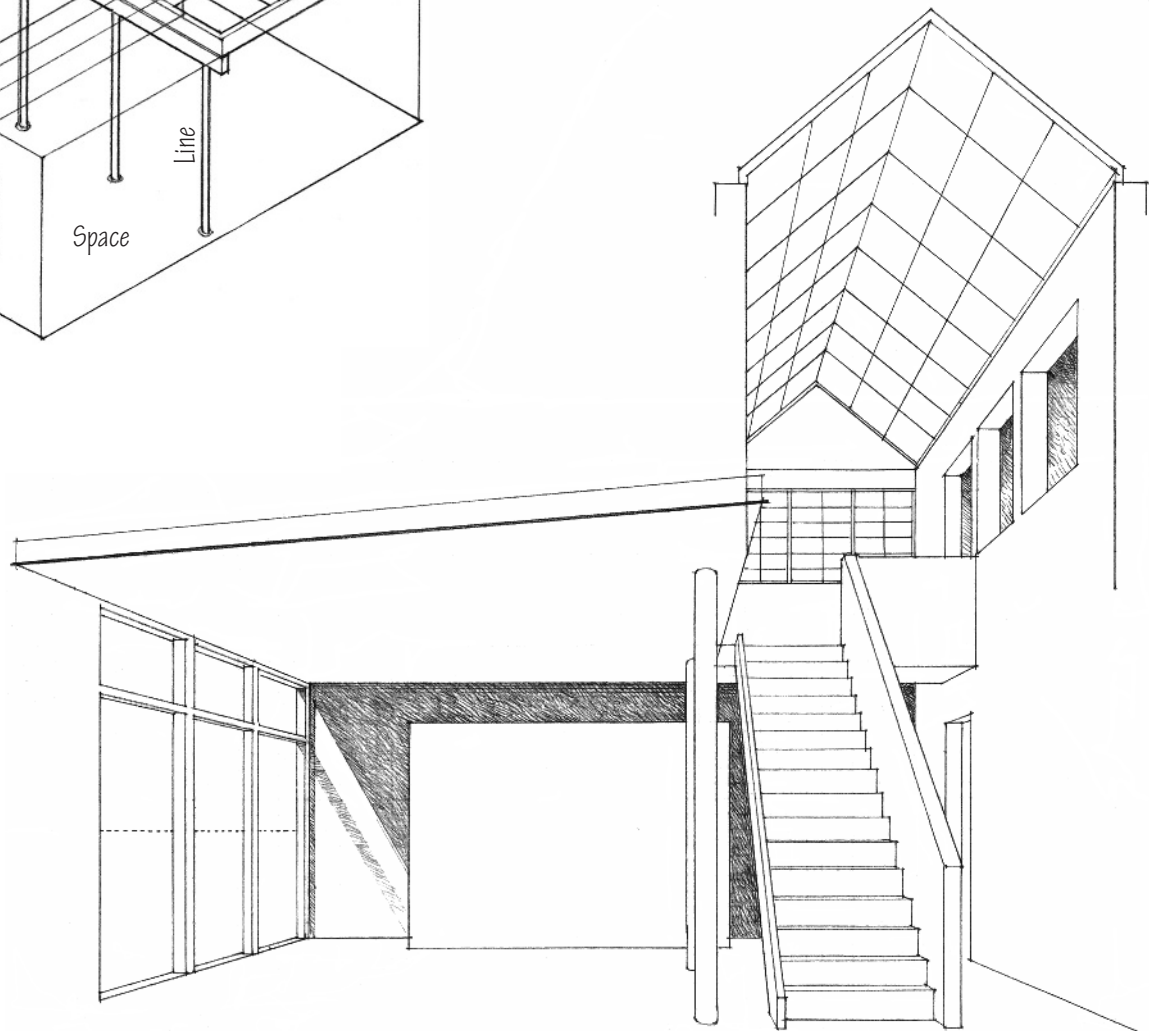
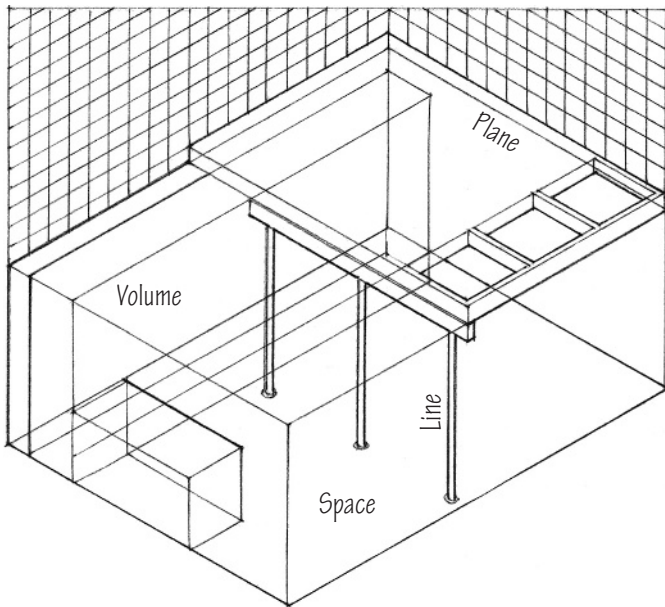
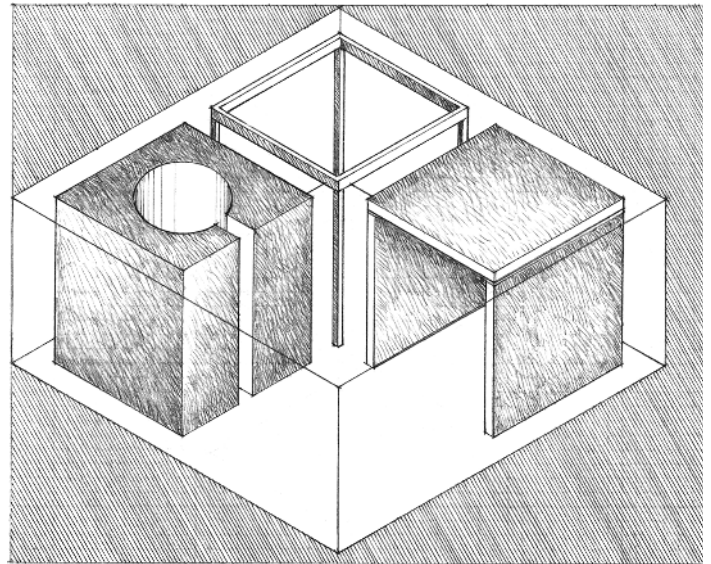

SHAPING INTERIOR SPACE

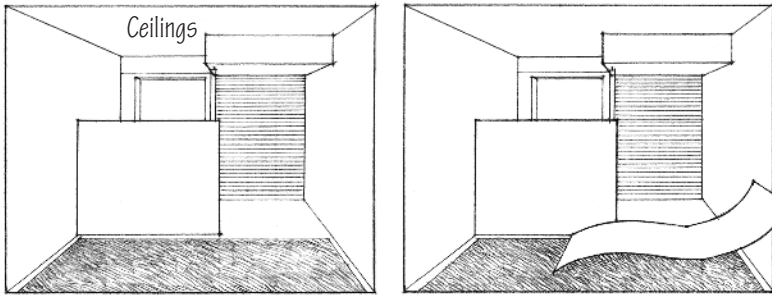
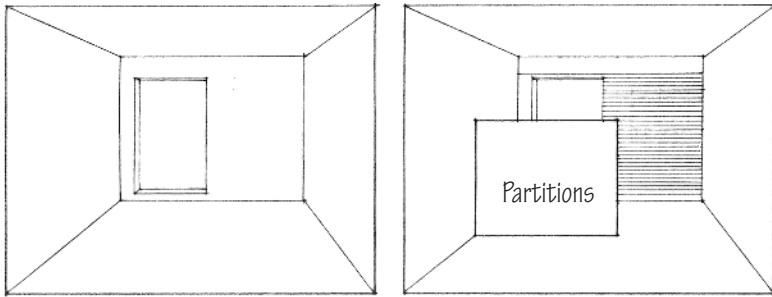

Although a building's structural system sets up the basic form and pattern of its interior spaces, these spaces are ultimately structured by the elements of interior design. The term "structure" is not used here in the sense of physical support. It refers to the selection and arrangement of interior elements such that their visual relationships define and organize the interior space of a room.

Non-load-bearing partitions and suspended ceilings are often used to define or modify space within the structural framework or shell of a building.

The color, texture, and pattern of wall, floor, and ceiling surfaces affect our perception of their relative positions in space and our awareness of the room's dimensions, scale, and proportion.

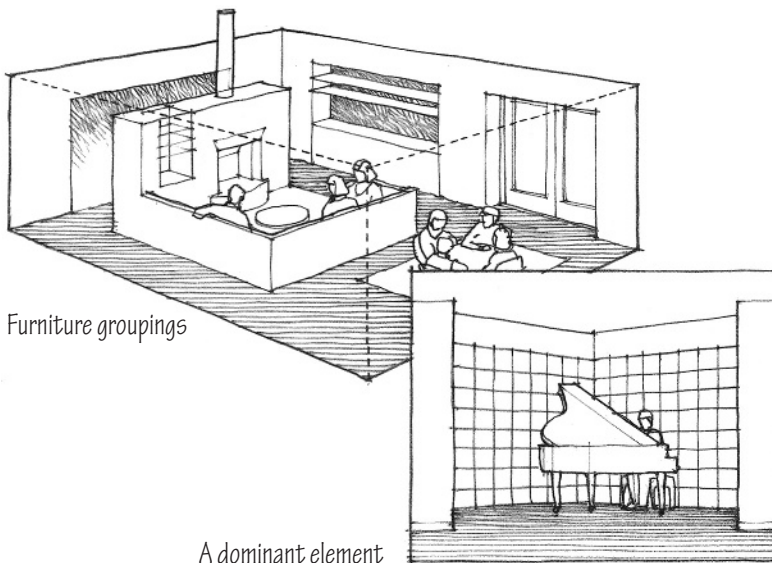

Furniture groupings

A dominant element

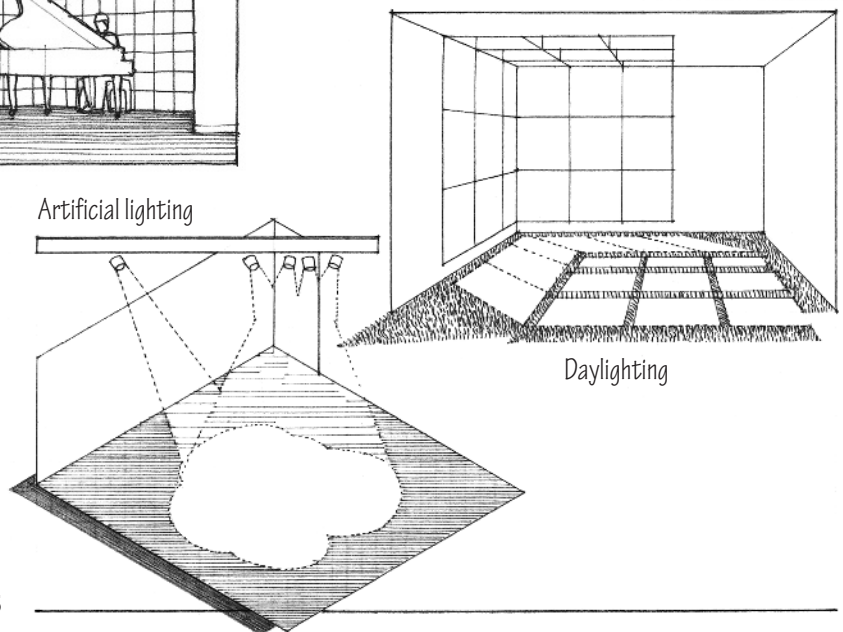

Structuring Space with Interior Design Elements

Within a large space, the form and arrangement of furnishings can divide areas, provide a sense of enclosure, and define spatial patterns.

Lighting, and the light and dark patterns it creates, can call our attention to one area of a room, deemphasize others, and thereby create divisions of space.

Even the acoustic nature of a room's surfaces can affect the apparent boundaries of a space. Soft, absorbent surfaces muffle sounds and can diminish our awareness of the physical dimensions of a room. Hard surfaces that reflect sounds within a room help to define its physical boundaries. Echoes can suggest a large volume.

Finally, space is structured by the way we use it. The nature of our activities and the rituals we develop in performing them influence how we plan, arrange, and organize interior space.

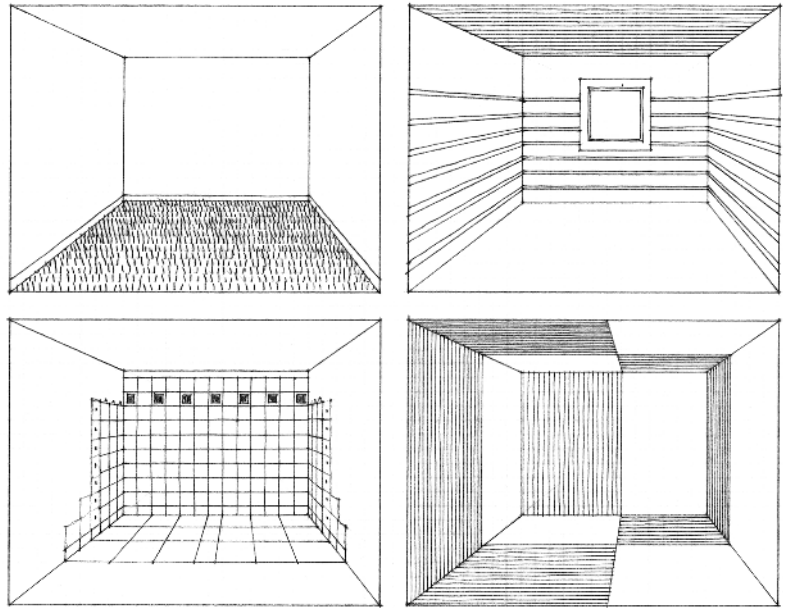

Color, texture, and pattern

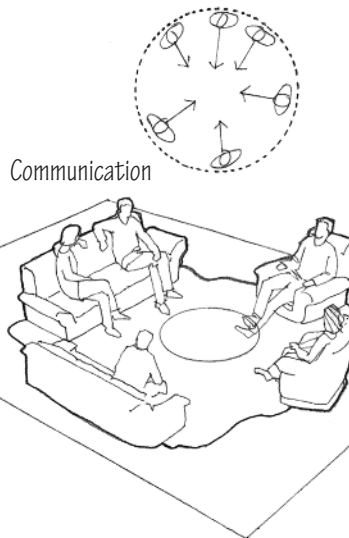
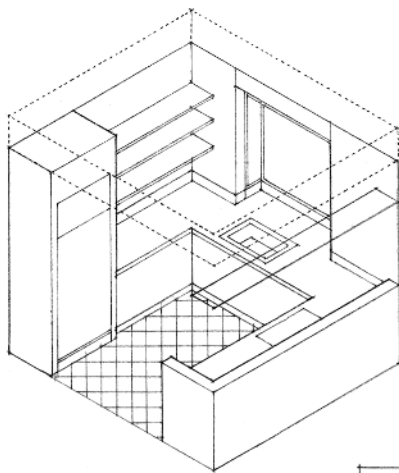

Communication

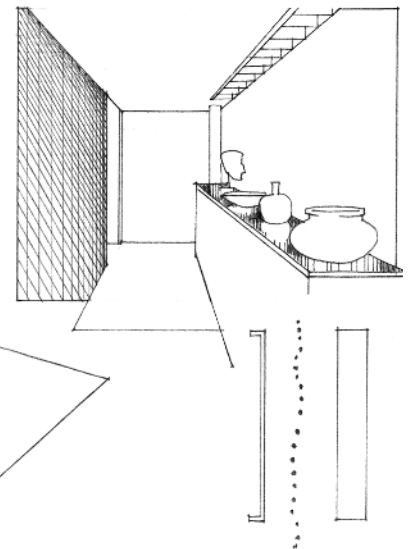

Movement

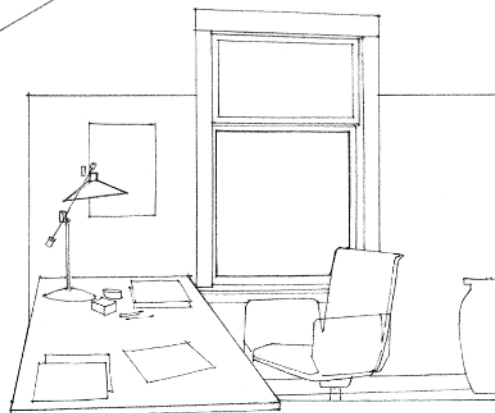

Individual and group activities

SPATIAL FORM

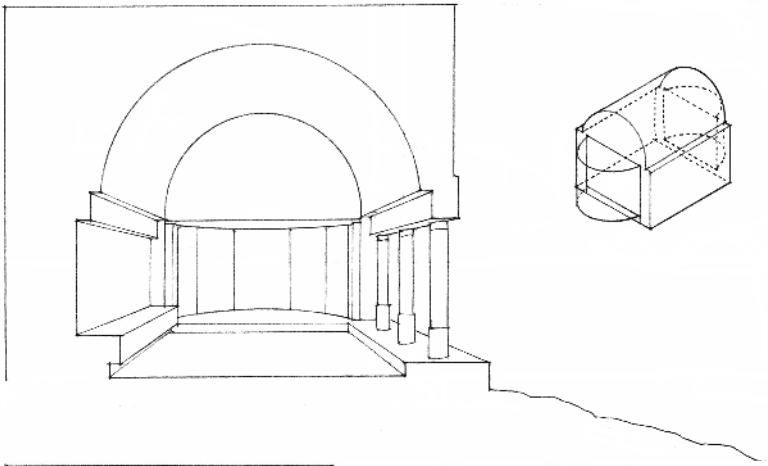

Interior spaces are formed first by a building's structural system, further defined by wall and ceiling planes, and related to other spaces by windows and doorways. Every building has a recognizable pattern of these elements and systems. Each pattern has an inherent geometry that molds or carves out a volume of space into its likeness.

It is useful to be able to read this *figure-ground* relationship between the form of space-defining elements and that of the space defined. Either the structure or the space can dominate this relationship. Whichever appears to dominate, we should be able to perceive the other as an equal partner in the relationship.

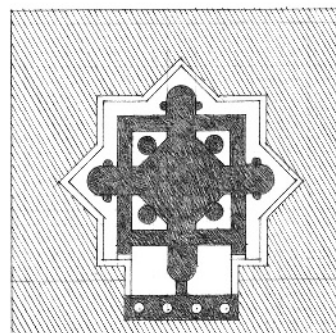
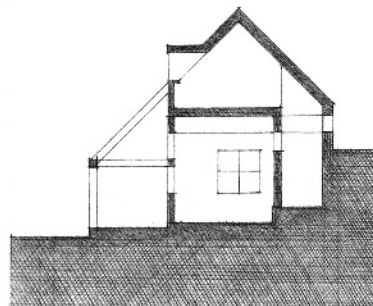
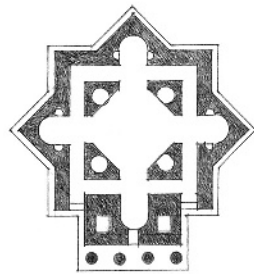
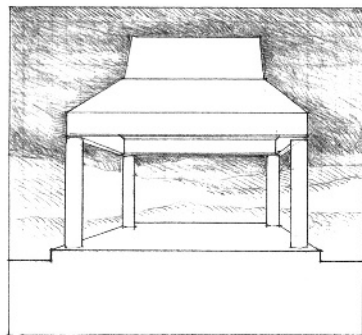
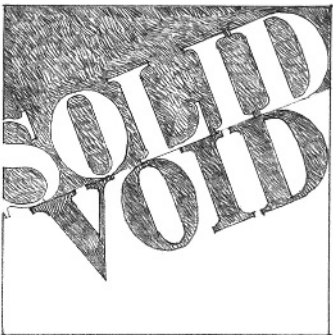
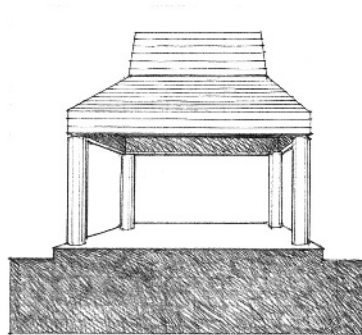
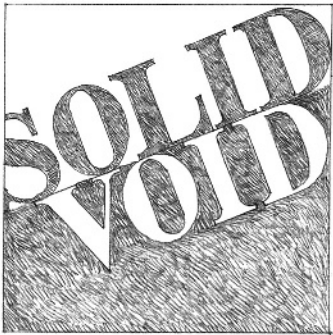

It is equally useful to see the alternating figure—ground dominance occurring as interior design elements, such as tables and chairs, are introduced and arranged within an interior space.

When a chair is placed in a room, it not only occupies space, it also creates a spatial relationship between itself and the surrounding enclosure. We should see more than the form of the chair. We should also recognize the form of the space surrounding the chair after it has filled some of the void.

As more elements are introduced into the pattern, the spatial relationships multiply. The elements begin to organize into sets or groups, each of which not only occupies space but also defines and articulates the spatial form.

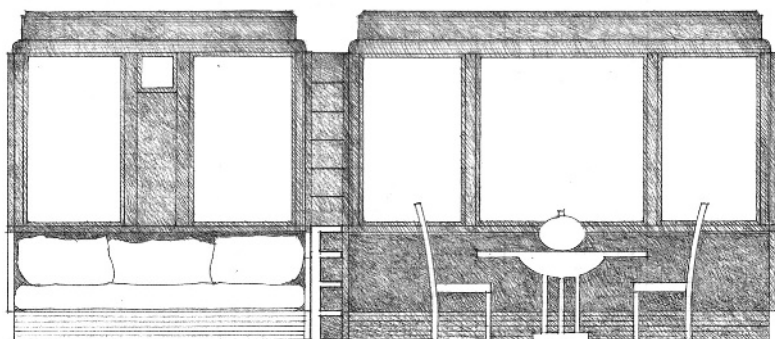
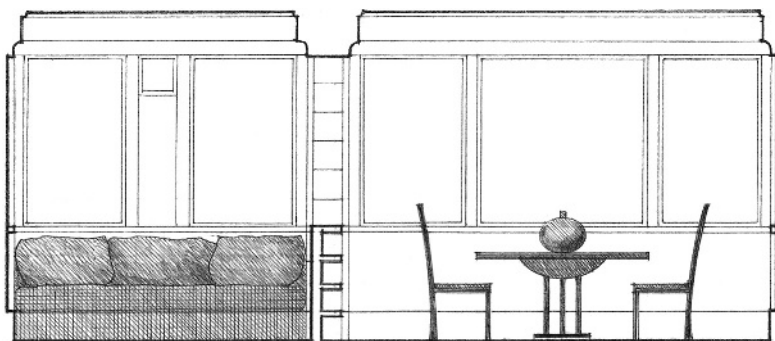
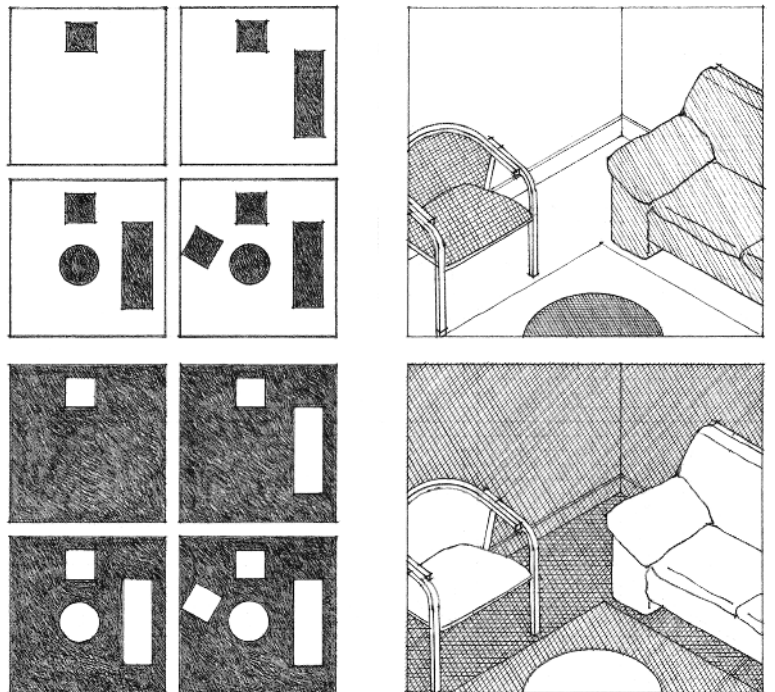
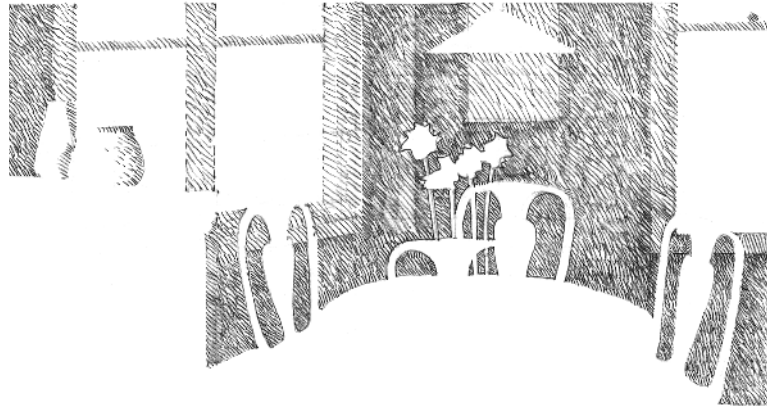

SPATIAL DIMENSIONS

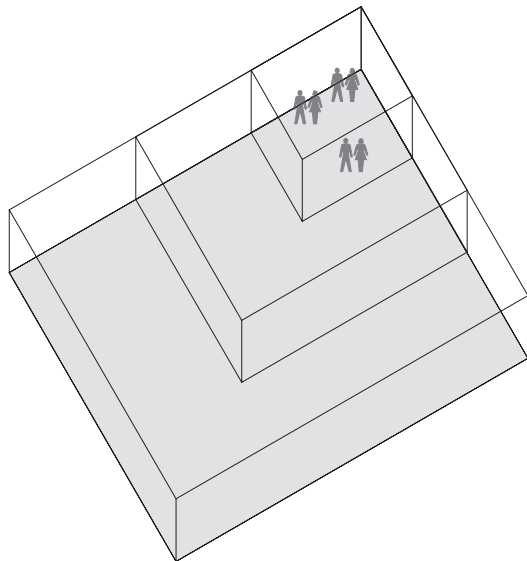
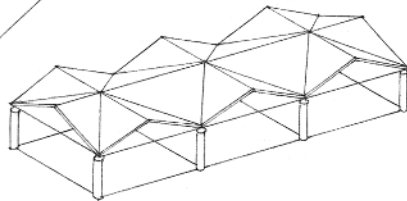
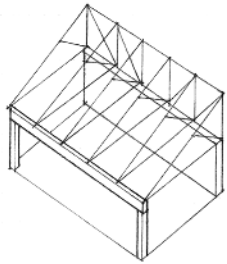
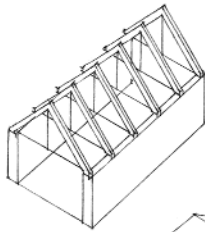
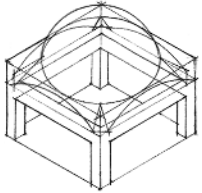
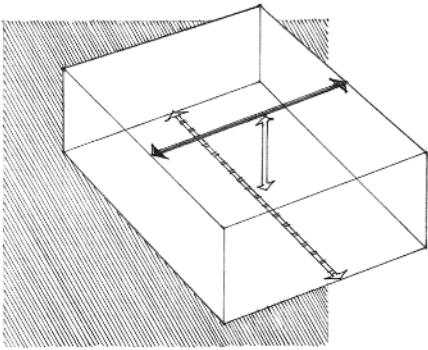

The dimensions of interior space, like spatial form, are directly related to the nature of a building's structural system—the strength of its materials and the size and spacing of its members. The dimensions of a space, in turn, determine a room's proportion and scale and influence the way it is used.

One horizontal dimension of space, its width, has traditionally been limited by the materials and techniques used to span it. Today, given the necessary economic resources, almost any architectural structure is technically possible. Wood or steel beams and concrete slabs can span up to 30 feet (9 m). Wood or steel trusses can span even farther, up to 100 feet (30 m) or more. Longer roof spans are possible with space frames and a variety of curved structures, such as domes, suspension systems, and membranes supported by air pressure.

Within the bounds of structural necessity, the width of an interior space should be established by the requirements of those who use the space and their need to set boundaries for themselves and their activities.

Building designers have traditionally developed spatial relationships by sketching and model building. *Computer-aided design (CAD)* and *building information management (BIM)* software systems are changing the way that building designers work. These computer technologies allow designers to build interactive three-dimensional computer models of buildings, and to coordinate building systems as they design.

Modeling a building with a 3D CAD system can provide higher productivity, rapid generation of design alternatives, and removal of errors that result from disparities between different drawings. However, these systems do require special design and management skills.

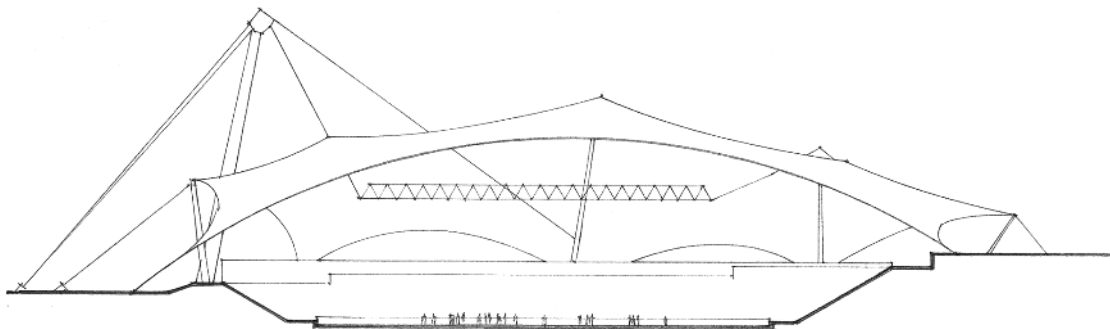

The other horizontal dimension of space, its length, is limited by desire and circumstance. Together with width, the length of a space determines the proportion of a room's plan shape.

A square room, where the length of the space equals its width, is static in quality and often formal in character. The equality of the four sides focuses our attention in on the room's center. This centrality can be enhanced or emphasized by covering the space with a pyramidal or dome structure.

To deemphasize the centrality of a square room, the form of the ceiling can be made asymmetrical, or one or more of the wall planes can be treated differently from the others.

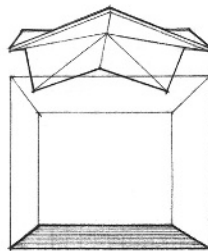
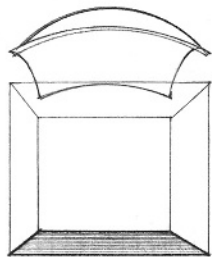
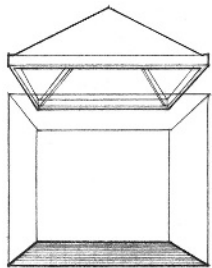
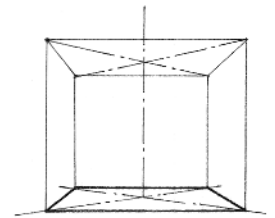
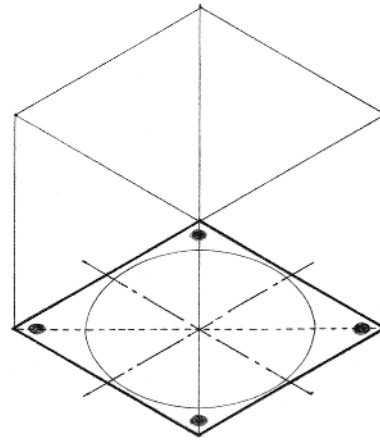
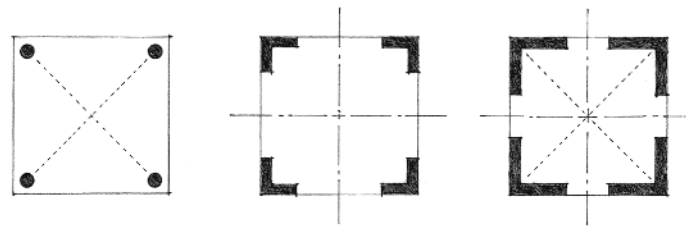

Pyramids, domes, and similar roof forms can emphasize the centrality of square spaces.

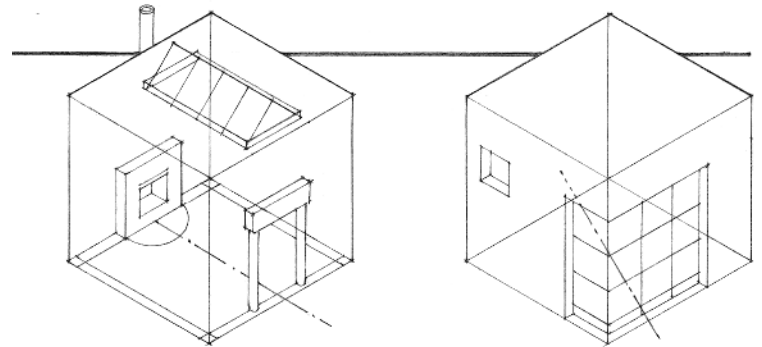

The placement of architectural elements, such as windows and stairways, can deemphasize the centrality of square spaces.

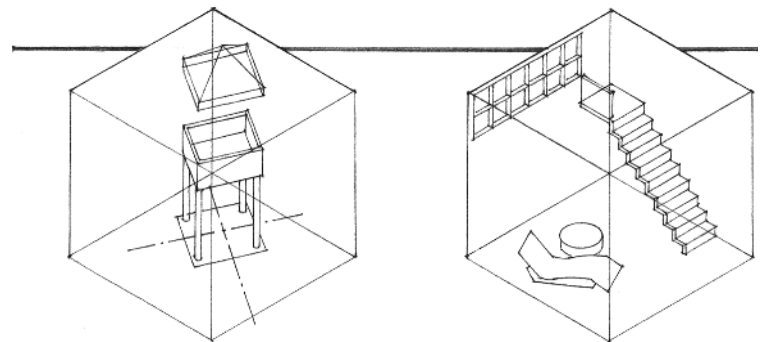

RECTANGULAR SPACES

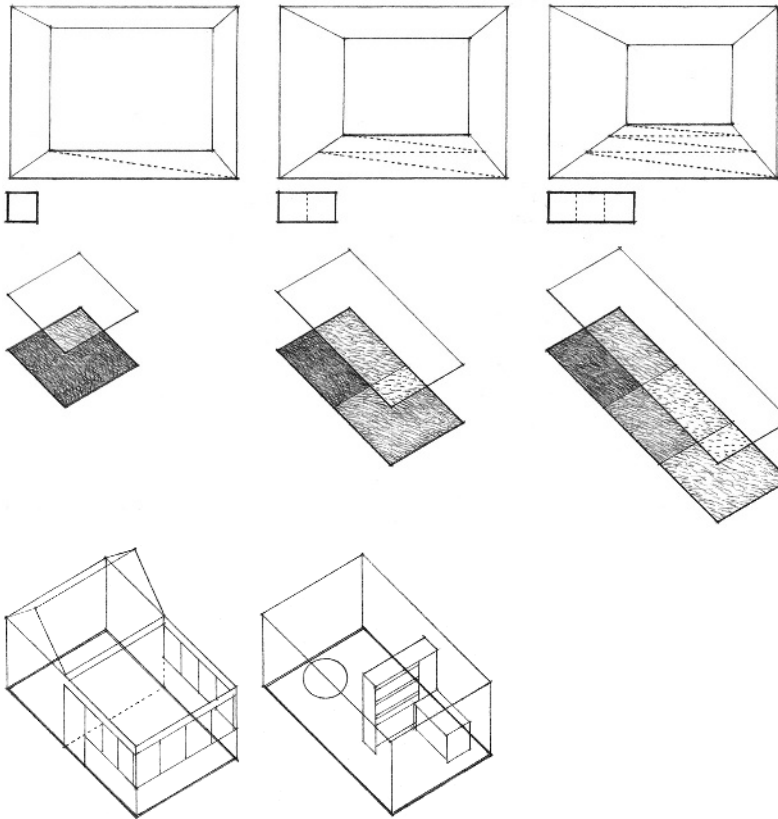

Square rooms are rare and distinctive. More often, a room will have a length greater than its width. A rectangular space, normally spanned across its width, is eminently flexible. Its character and usefulness are determined not only by its proportion of width to length, but also by the configuration of its ceiling, the pattern of its windows and doorways, and its relationship to adjacent spaces.

When the length of a space is greater than twice its width, it tends to dominate and control the room's layout and use. Given sufficient width, the space can be divided into a number of separate but related areas.

A space whose length greatly exceeds its width encourages movement along its long dimension. This characteristic of linear spaces makes them suitable for use as gallery spaces or as connectors of other spaces.

Horizontal dimensions alone do not determine the ultimate qualities and usefulness of a space. They only suggest opportunities for development.

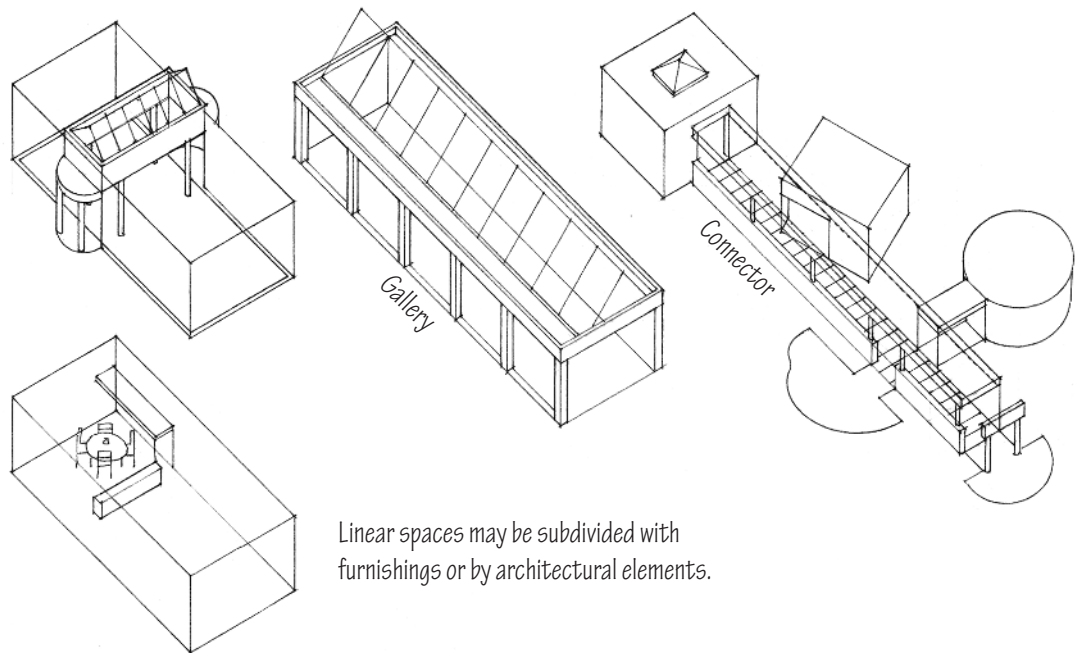

Linear spaces may be subdivided with furnishings or by architectural elements.

Both square and rectangular spaces can be altered by addition or subtraction, or by merging with adjacent spaces. These modifications can be used to create an alcove space or to reflect an adjoining element or site feature.

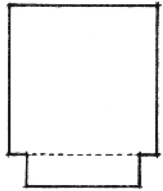

Extension

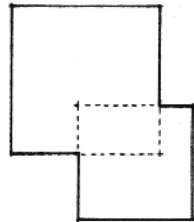

Addition

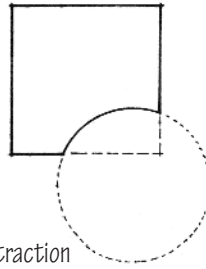

Subtraction

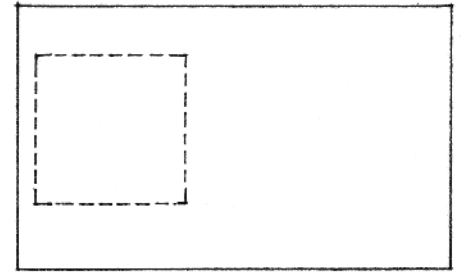

Merging

Altering Space

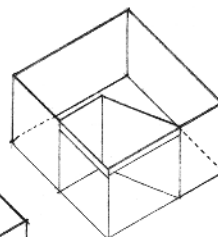
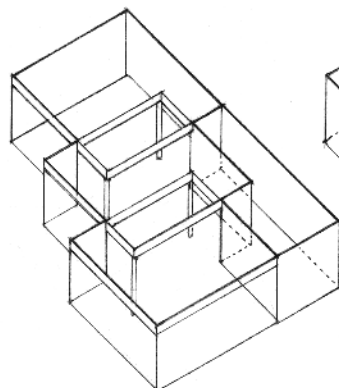
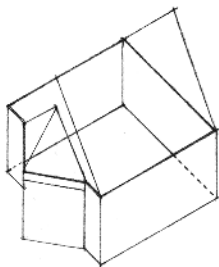
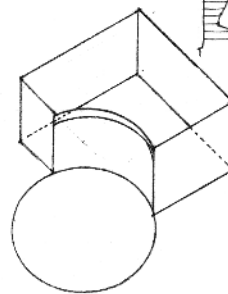
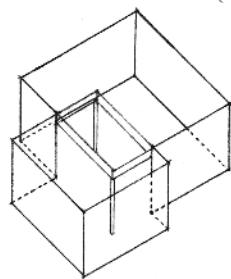
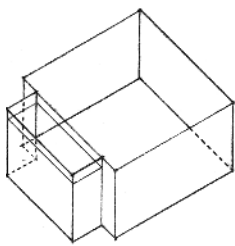
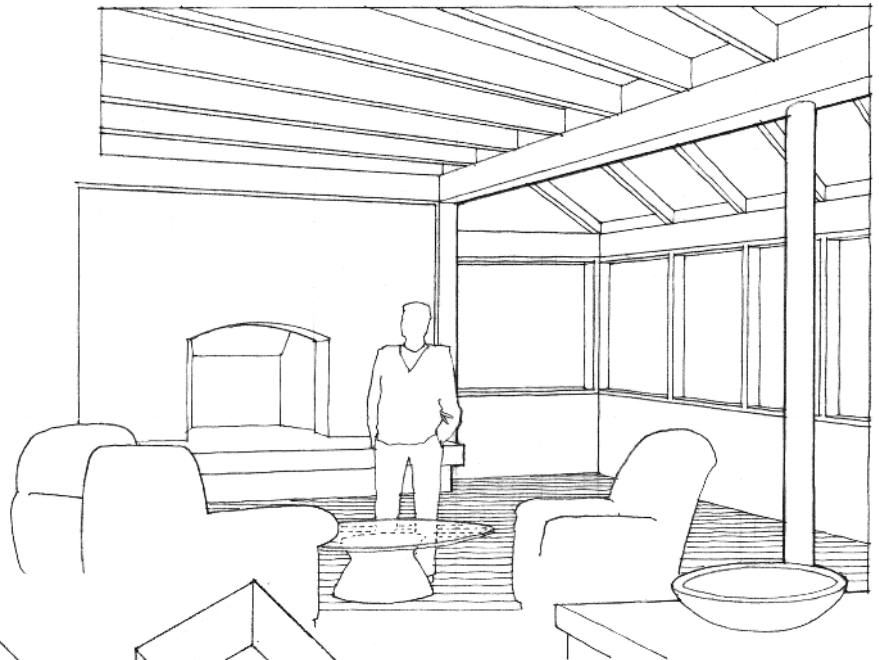

CURVILINEAR SPACES

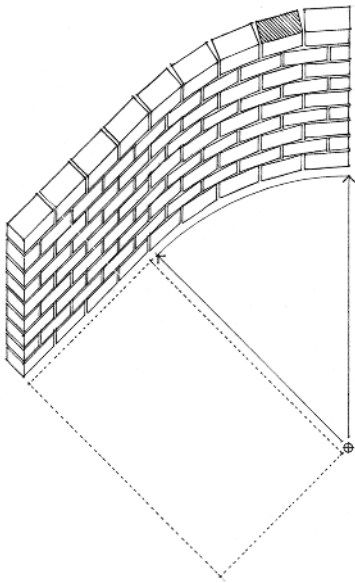

The radius of the curvature of a wall depends on the scale and flexibility of the material used to build it.

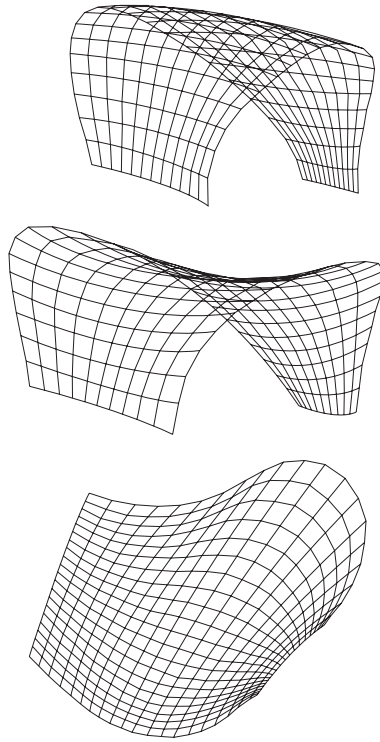

The nature of building materials and the techniques used to assemble them have traditionally established rectangular spaces as the norm. Curvilinear spaces are exceptional and usually reserved for special circumstances. However, the advent of 3D CAD systems has made the design and construction of curvilinear spaces more feasible.

The simplest curvilinear space is a circular one. It is compact and self-centering. Although it creates a focus on its center, a circular space also relates to the surrounding space equally in all directions. It has no front, back, or sides, unless these are defined by other elements.

An elliptical space is more dynamic, having two centers and unequal axes.

Other curvilinear spaces can be seen as transformations of circular or elliptical spaces that have been combined in an overlapping manner. The use of three-dimensional computer modeling is increasing the ease of designing complex curves.

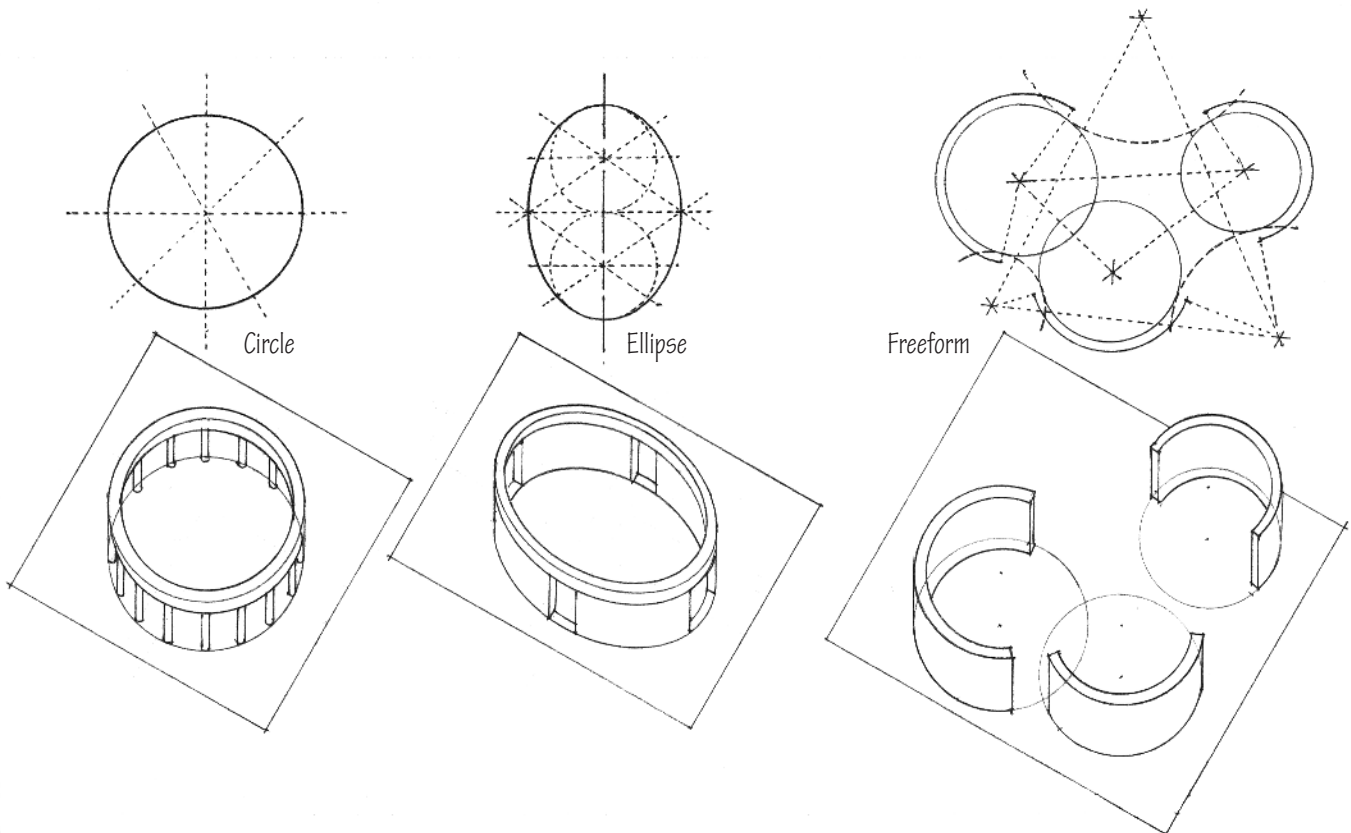

Within a rectilinear context, a curvilinear space is highly visible. Its contrasting geometry can be used to express the importance or uniqueness of its function. It can define a freestanding volume within a larger space. It can serve as a central space about which other rooms are gathered. It can articulate the edge of a space and reflect an exterior condition of the building site.

Curved walls are dynamic and visually active, leading our eyes along their curvature. The concave aspect of a curved wall encloses and focuses space inward, while its convex aspect pushes space outward.

An important consideration when we are dealing with a curvilinear space is the integration of furniture and other interior elements into its volume. One way of resolving conflicting geometries is to arrange interior forms as freestanding objects within the curvilinear space. Another is to integrate the form of built-in furniture and fixtures with the curved boundaries of the space.

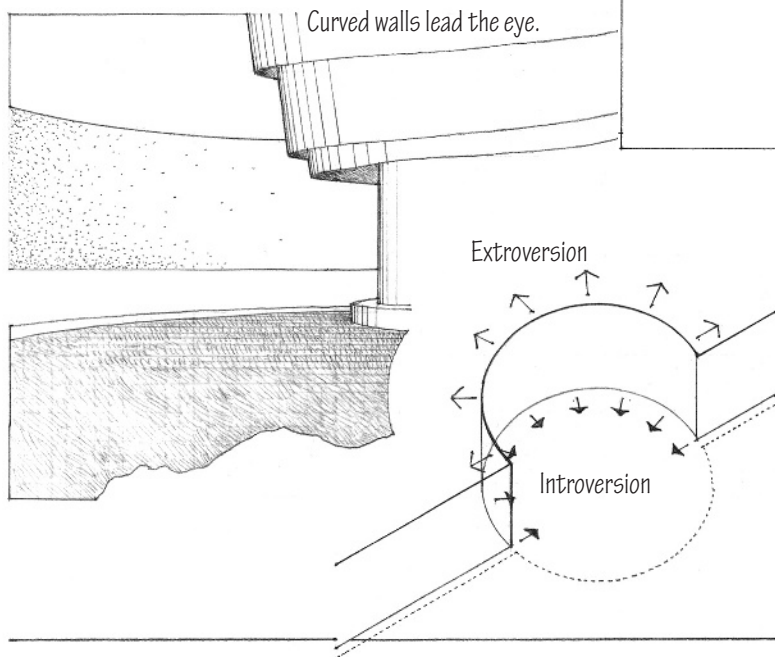
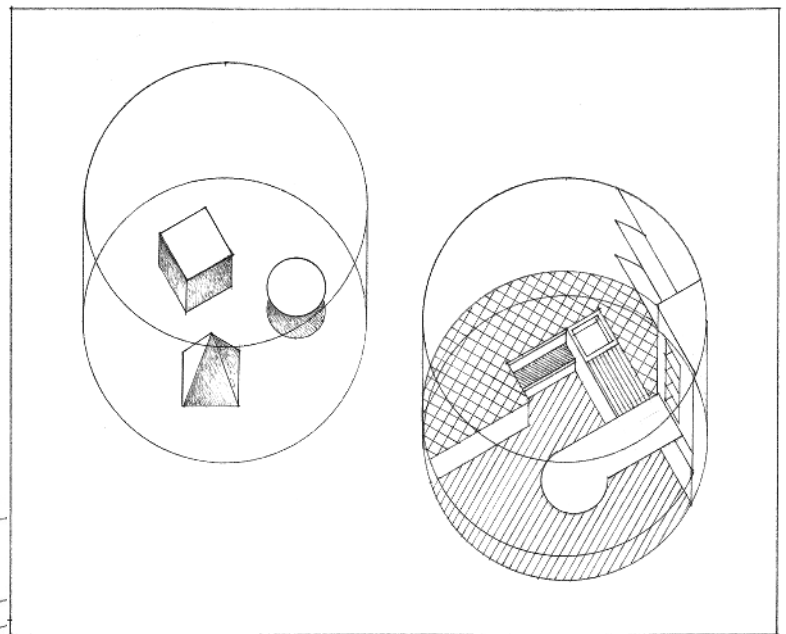
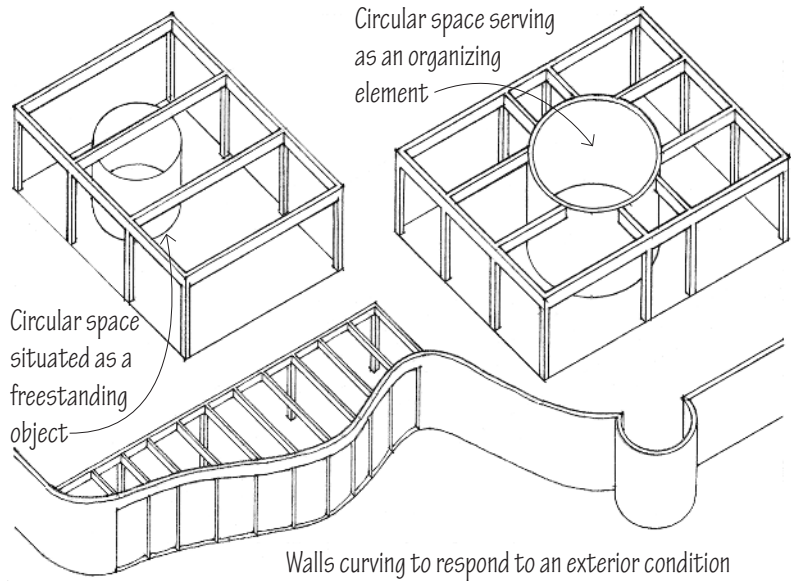

Furnishings may be placed as freestanding objects within a curvilinear space or be integrated within the curved forms.

THE VERTICAL DIMENSION OF SPACE

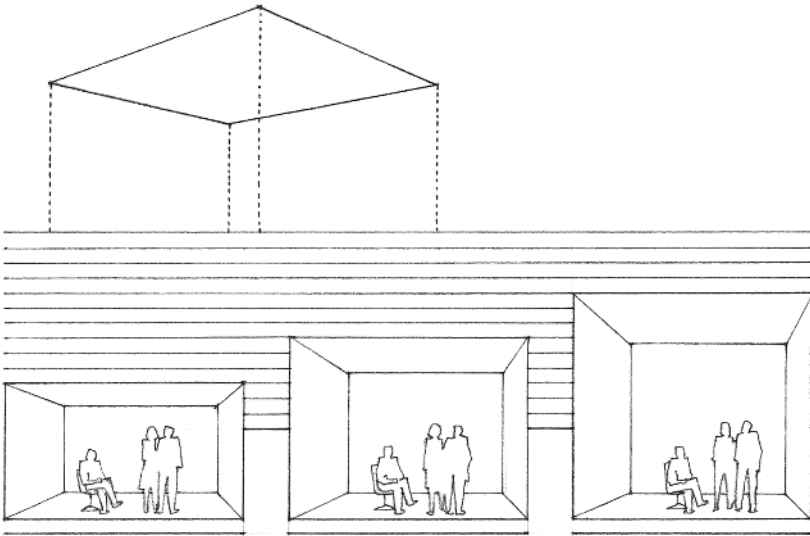

The third dimension of interior space, its height, is established by the ceiling plane. This vertical dimension is as influential as the horizontal dimensions of a space in forming the spatial quality of a room. Design of the ceiling is an important element of interior design.

While our perception of a room's horizontal dimensions is often distorted by the foreshortening of perspective, we can more accurately sense the relationship between the height of a space and our own body height. A measurable change in the height of a ceiling seems to have a greater effect on our impression of a space than a similar change in its width or length.

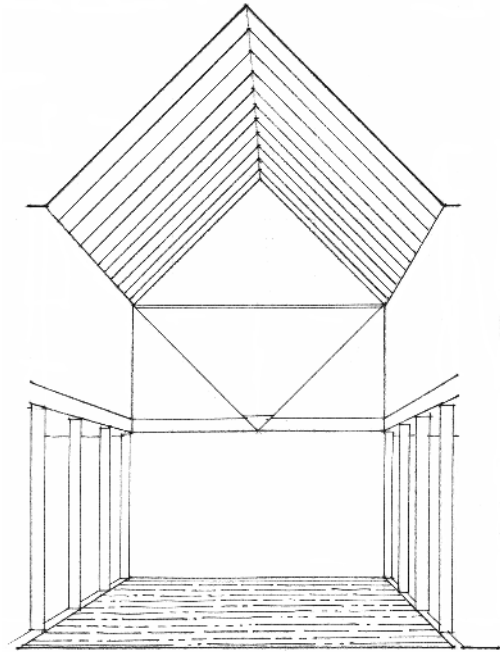
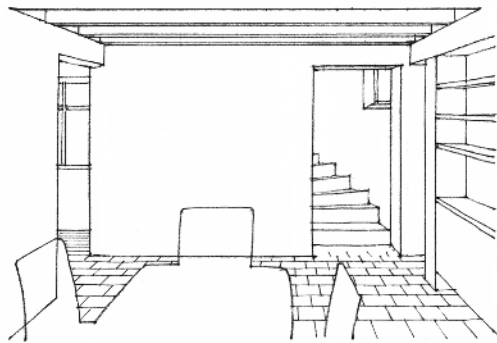
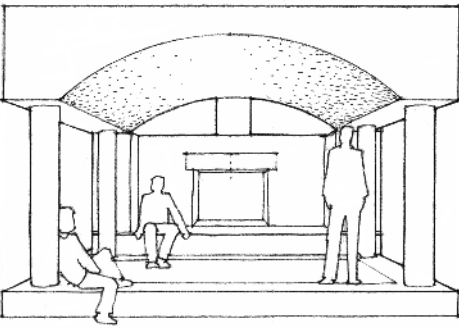

Varying the ceiling height can have a powerful effect on the perceived scale of a space.

High ceilings are often associated with feelings of loftiness or grandeur. Low ceilings may connote cavelike coziness and intimacy. However, our perception of the scale of a space is affected not by the height of the ceiling alone, but by its relationship to the width and length of the space as well.

A ceiling defined by the floor plane of the room above it is typically flat. A ceiling created by a roof structure can reflect its form and the manner in which it spans the space. *Shed, gable, and vaulted* ceiling forms give direction to space, while domed and pyramidal ceilings emphasize the center of a space.

Lowering part of a ceiling can foster intimacy, modify acoustics, or add visual texture. Interior *soffits, canopies, and clouds* can be used to partially lower a ceiling at its perimeter, or over areas of interest.

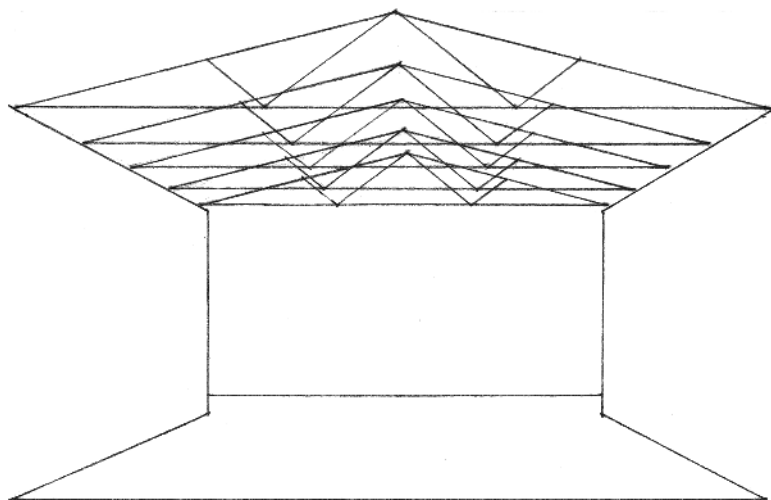

The roof structure can sometimes be left exposed, giving texture, pattern, and depth to the ceiling plane.

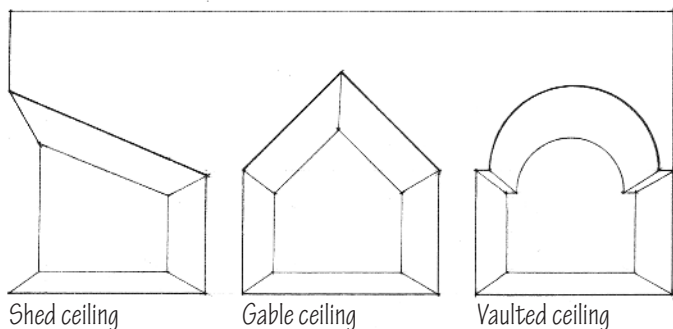

Shed ceiling

Gable ceiling

Vaulted ceiling

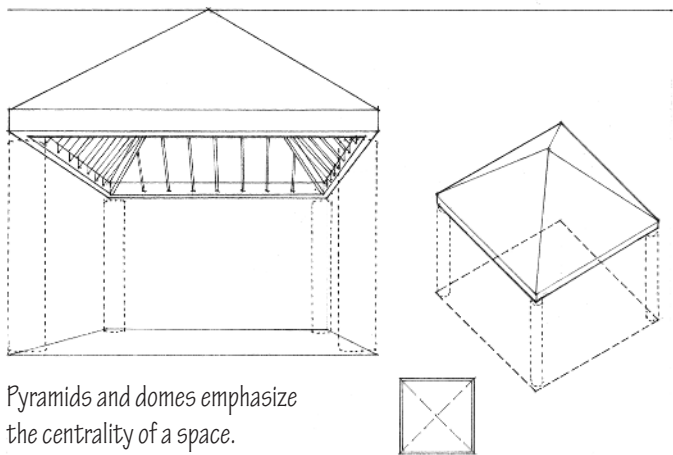

Pyramids and domes emphasize the centrality of a space.

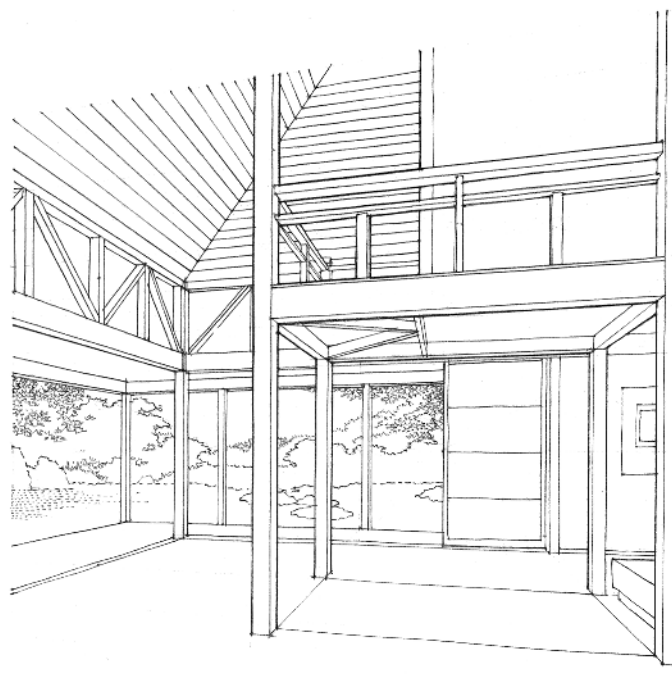

SPATIAL TRANSITIONS

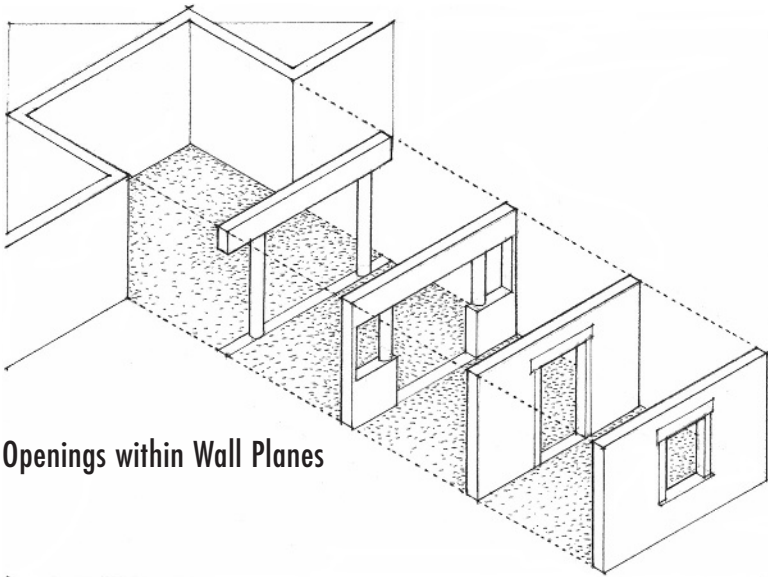

Openings within Wall Planes

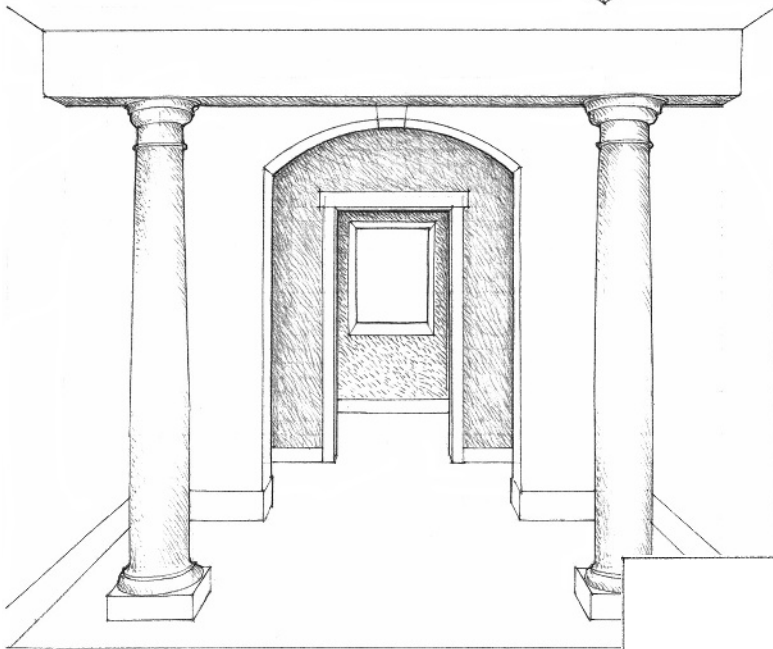

Although individual spaces may be designed and formed for a certain purpose or to house certain activities, they are gathered together within a building's enclosure because they are functionally related to one another, are used by a common group of people, or share a common purpose. How interior spaces are related to one another is determined not only by their relative position in a building's spatial pattern, but also by the nature of the spaces that connect them and the boundaries they have in common.

Floor, wall, and ceiling planes serve to define and isolate a portion of space. Of these, the wall plane, being perpendicular to our normal line of sight, has the greatest effect as a spatial boundary. It limits our visual field and serves as a barrier to our movement. Openings created within the wall plane for windows and doorways reestablish contact with the surrounding spaces from which the room was originally cut.

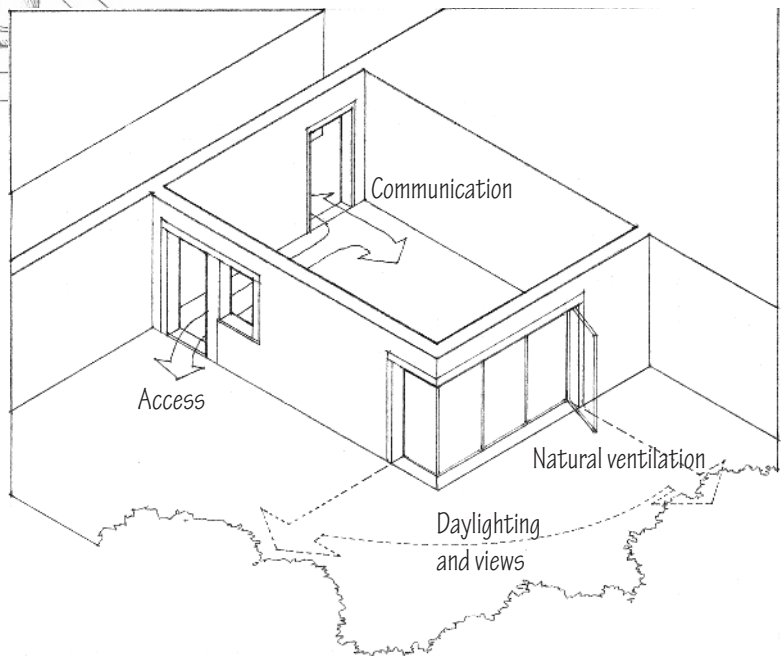

Doorways provide physical access from one space to another. When closed, they shut a room off from adjacent spaces. When open, they establish visual, spatial, and acoustical links between spaces. Large open doorways erode the integrity of a room's enclosure and strengthen its connection with adjacent spaces or the outdoors.

The thickness of the wall separating two spaces is exposed at a doorway. This depth determines the degree of separation we sense as we pass through the doorway from one space to another. The scale and treatment of the doorway itself can also provide visual clues to the nature of the space being entered.

The number and location of doorways along a room's perimeter affect our pattern of movement within the space, and the ways we may arrange its furnishings and organize our activities.

The widths of door openings affect the ease of movement for people and furnishings. A 36-inch (914-mm) wide doorway is reduced to about 32 inches (813 mm) when the thickness of the open door and that of its hardware are taken into consideration. Clear openings of less than 32 inches (813 mm) become barriers to standard wheelchairs, affecting *accessibility*, *visitability*, and *aging-in-place*.

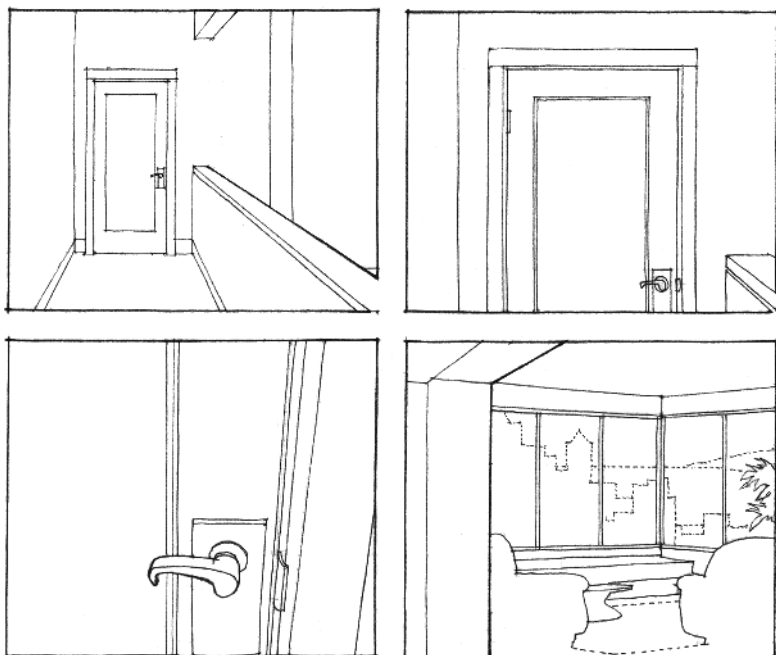
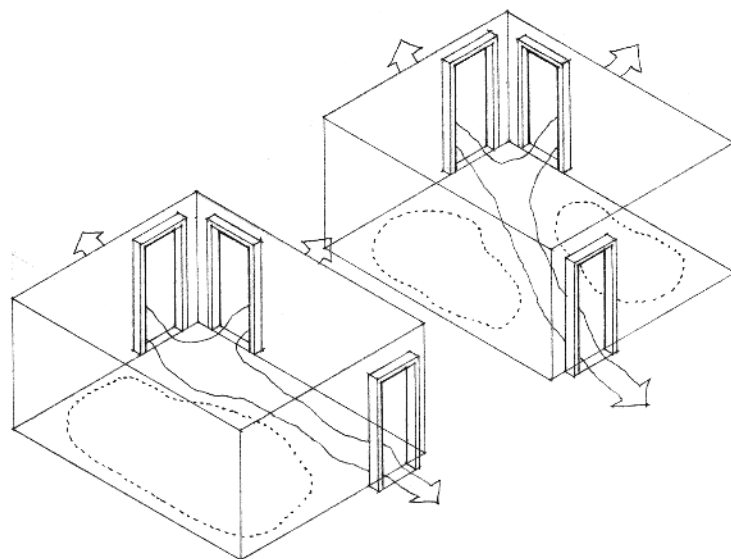
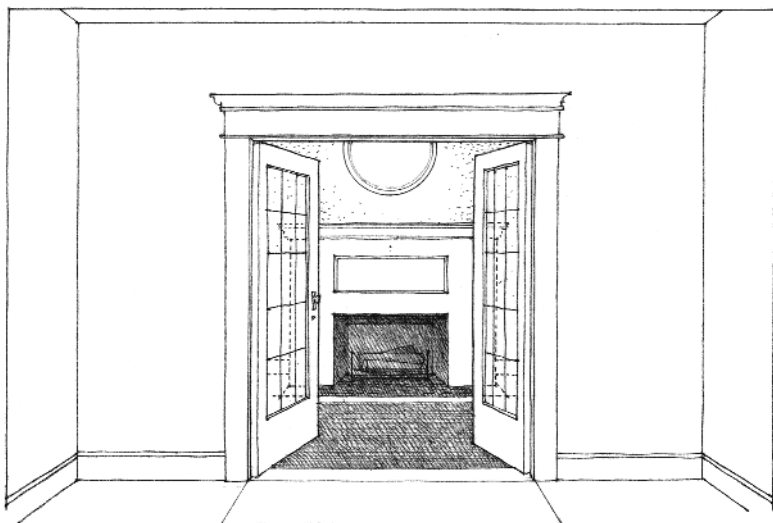

Doorway locations affect our patterns of movement and activities within a room.

WINDOWS

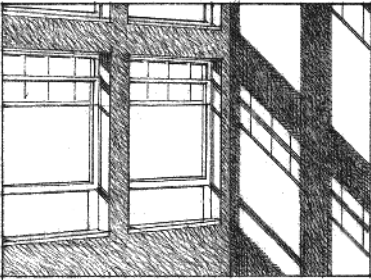

Daylighting

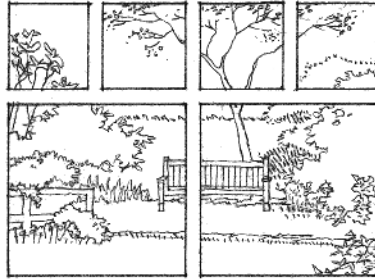

Framing views

Windows let light and air into the interior spaces of buildings and provide views of the outdoors, or from one space to another. Their size and placement, relative to the wall plane in which they occur, also affect the degree of separation between an interior space and the exterior environment. Views to the outside and *natural ventilation* are important elements in sustainable design.

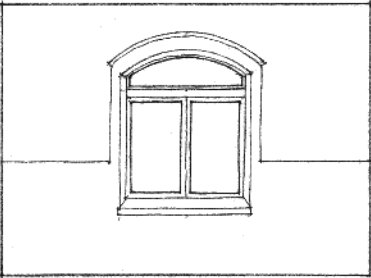

Degree of enclosure

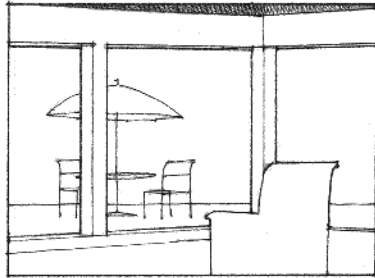

...or transparency

Windows framed within a wall plane attract our attention with their brightness and outlook but maintain the enclosure provided by the wall. Large windows and glass walls attempt, at least visually, to merge indoor and outdoor space. The visual treatment of the window frames in each case can either emphasize or minimize the perceived limits of interior space.

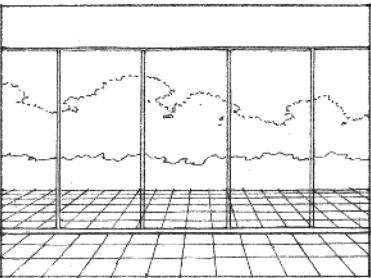

Thin frame

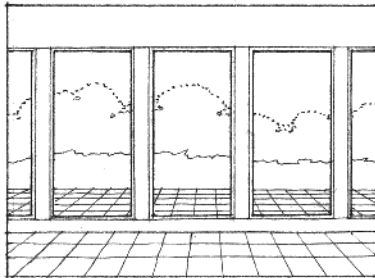

Thick frame

Interior windows can, in a similar manner, visually expand a room beyond its physical boundaries and allow it to become an integral part of the surrounding interior space.

Operable skylights allow overhead daylight to enter and excess heat to leave the building. They also provide building occupants with views of the sky.

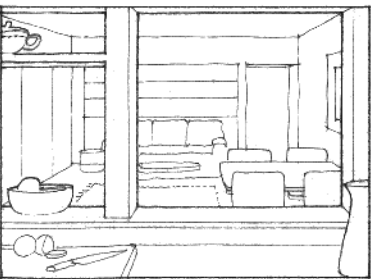

Interior windows

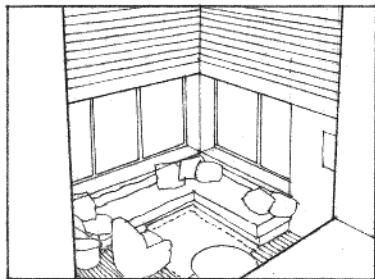

...connecting spaces

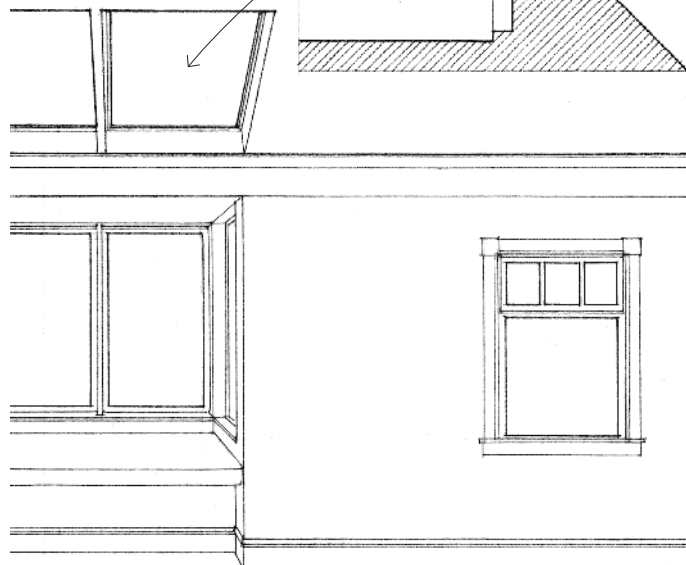
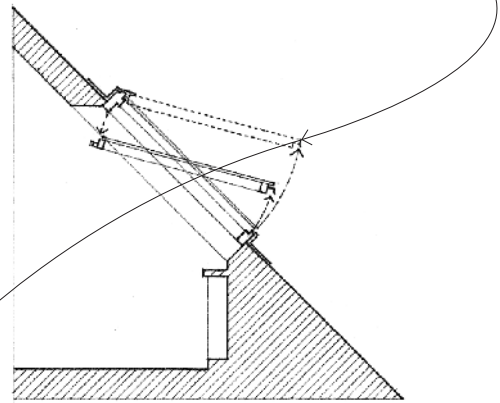

Stairways are also important forms of spatial transitions between rooms. An exterior set of steps leading to a building's entrance can serve to separate private domain from public passage and enhance the act of entry into a transitional space such as a porch or terrace. Entrances without steps support visitability and aging-in-place.

Interior stairways connect the various levels of a building. The manner in which they perform this function shapes our movement in space—how we approach a stairway, the pace and style of our ascent and descent, and what we have an opportunity to do along the way. Wide, shallow steps can serve as an invitation, while a narrow, steep stairway may lead to more private places. Landings that interrupt a flight of steps can allow a stairway to change direction and give us room for pause, rest, and outlook.

Designers are becoming more concerned with creating opportunities for movement within interior workplace spaces. One result of this has been the increasing use of wide stairs as seating areas, often connecting work or presentation spaces.

Active design focuses on the role of designers in dealing with the urgent health crises of obesity and related diseases such as diabetes. Active design guidelines go beyond Leadership in Energy and Environmental Design (LEED) programs to address people's varying needs and educate designers about opportunities to increase daily physical activity and include measures such as making stairs more visible and inviting. They seek to increase stair use by providing a conveniently located stair for everyday use, posting motivational signage to encourage stair use, and designing visible, appealing, and comfortable stairs.

The space a stairway occupies can be considerable, but its form can be fit into an interior in several ways. It can fill and provide a focus for a space, run along one of its edges, or wrap around a room. It can be woven into the boundaries of a space or be extended into a series of terraces.

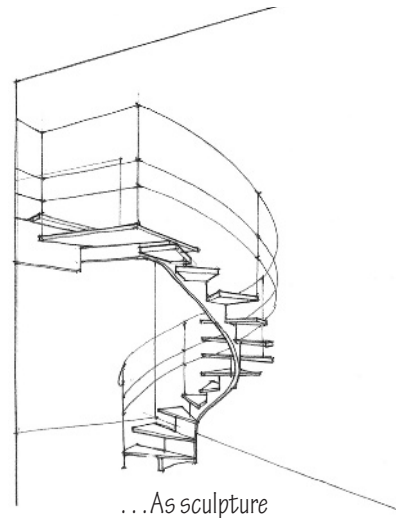
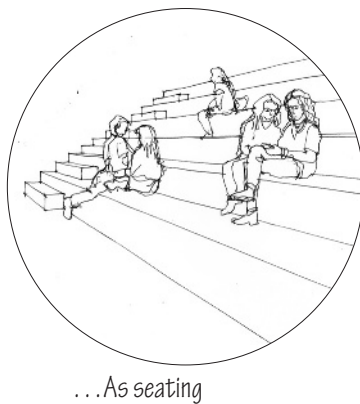
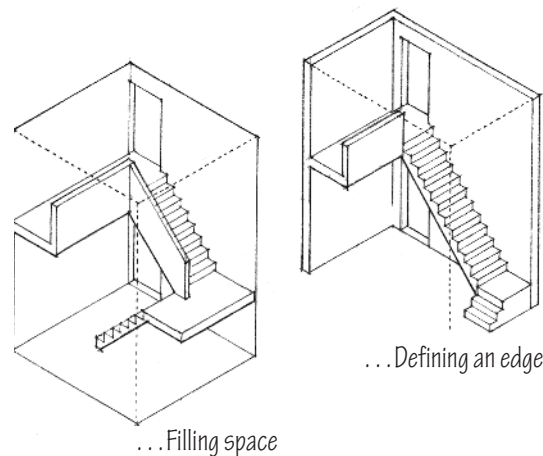
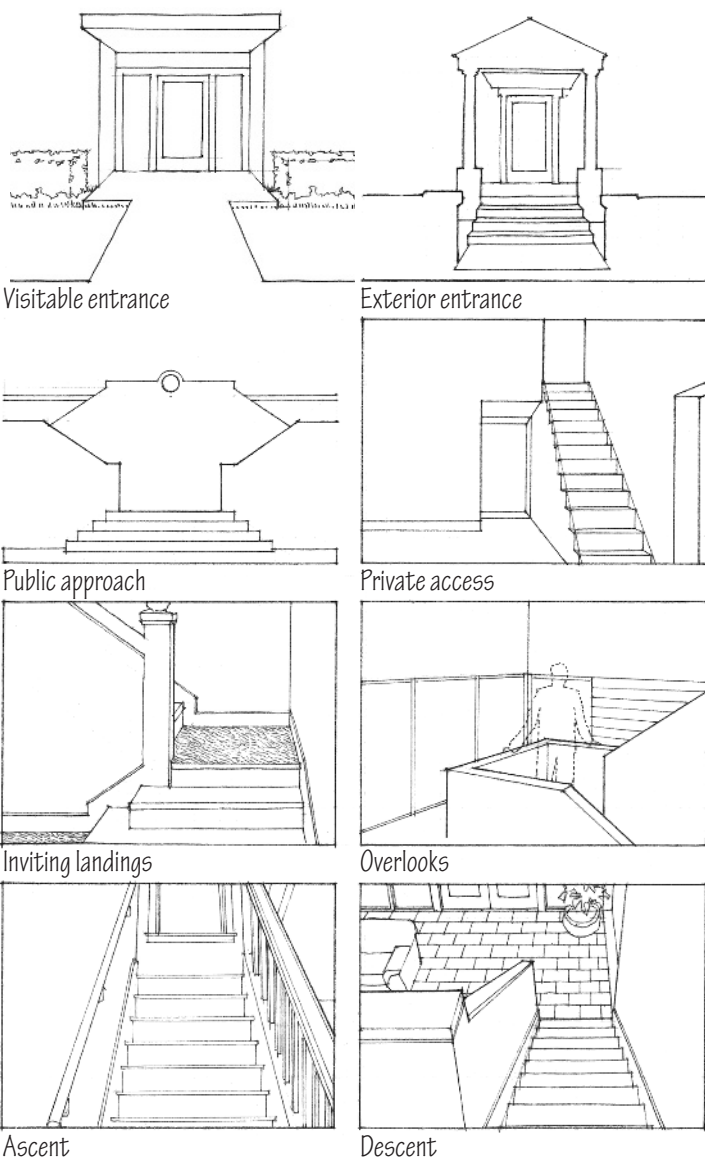

MODIFYING SPACE

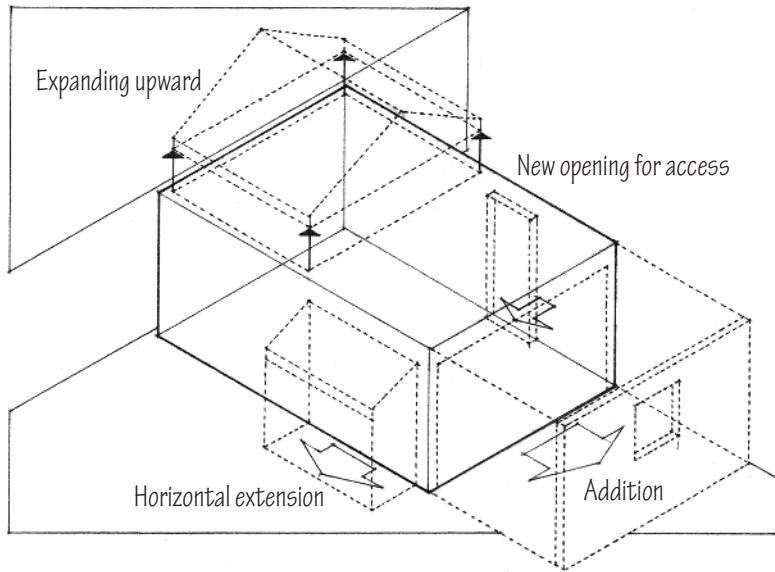

The architectural planning and design for a new building take into account the nature of the activities to be housed; the spatial requirements for form, scale, and light; and the desired relationships among the various interior spaces. When an existing building is to be used for activities other than those for which it was originally intended, however, activity requirements must be matched with the existing conditions. Where a misfit occurs, a modification of the existing spaces may be required.

Today, many interior renovations involve changes to existing buildings. Where the design involves changes in the building's use, the process is referred to as *adaptive reuse*. Reusing existing buildings can help preserve the historic qualities and architectural character of a built environment.

Two major types of alteration can be considered. The first involves structural changes in the boundaries of interior space and is more permanent in nature than the second. The second type of alteration involves nonstructural modifications and enhancement accomplished through interior design.

The acceptance of formerly forbidden accessory dwelling units (ADUs) offer opportunities to create residential units in existing owner-occupied one- to three-family buildings in certain neighborhoods. The ADUs create an opportunity to evolve older residences to meet 21st-century housing needs, while promoting long-term occupancy and neighborhood stability.

A structural change may involve removing or adding walls to alter the shape and rearrange the pattern of existing spaces, or to add on new space. When making such alterations, it is extremely important to understand the distinction between load-bearing walls and non-load-bearing *partitions*. It is, therefore, always advisable to consult a professional engineer or architect when making structural changes to a space.

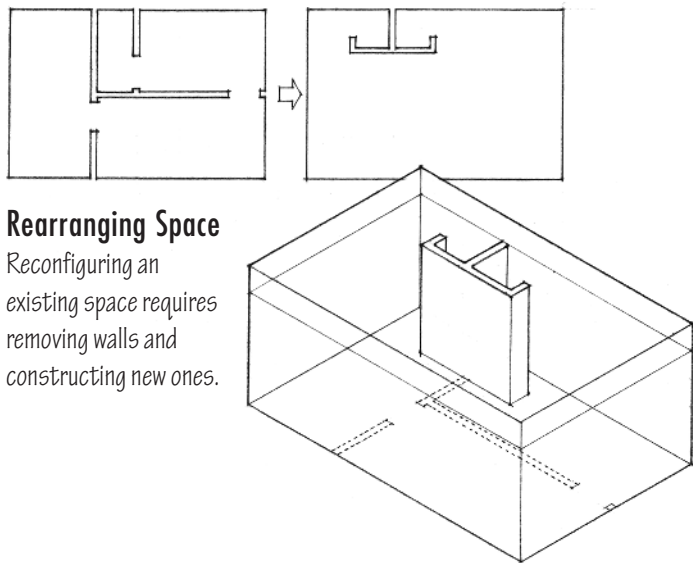

Rearranging Space

Reconfiguring an existing space requires removing walls and constructing new ones.

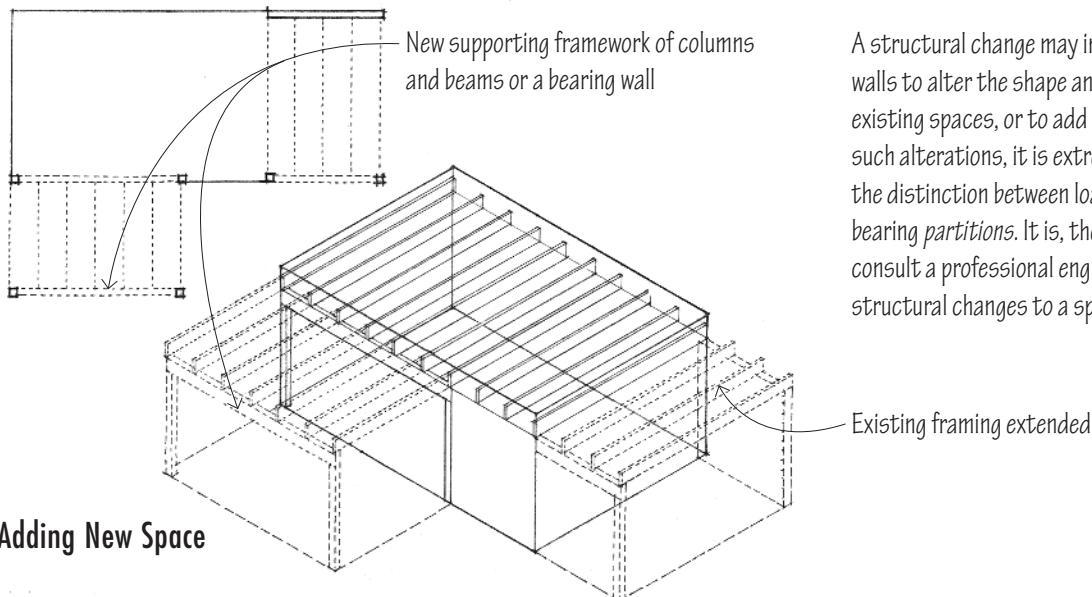

Adding New Space

Within the boundaries of a space, the existing pattern of openings can also be altered. Windows may be enlarged or added for better daylighting or to take advantage of a view. A doorway may be moved or added for better access to a room space or to improve the movement paths within the space. A large doorway may be created to merge two adjacent spaces. Any new or enlarged opening in a load-bearing wall requires a lintel or header sized to carry the wall load above the opening.

To add a stairway, daylight a space with skylights, or create a vertical relationship between two levels of space, structural changes in the floor or ceiling plane may be required. Alterations in these horizontal structures of a building may require that the edges of any new openings be reinforced and supported by a system of beams, columns, posts, or bearing walls.

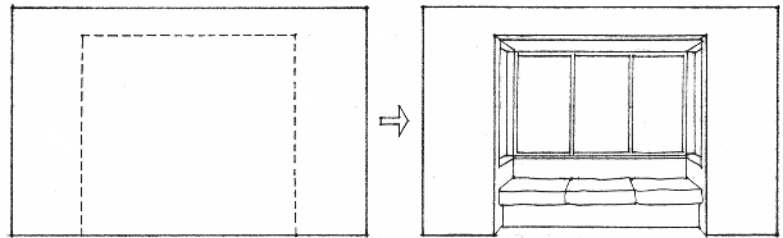

Extending space outward

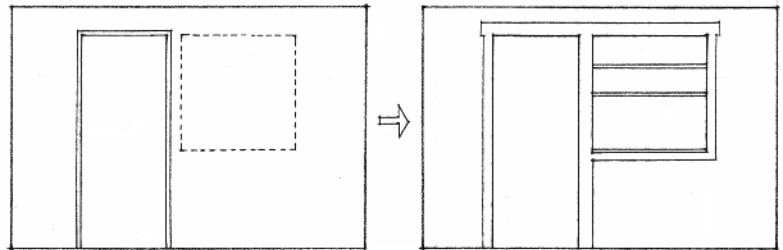

Enlarging an existing opening

New Wall Openings

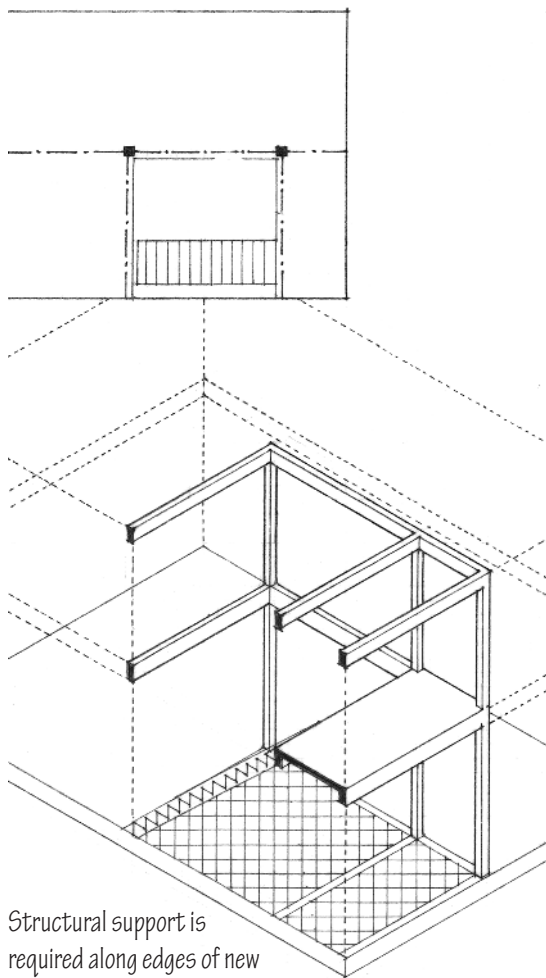

Structural support is required along edges of new floor and roof openings.

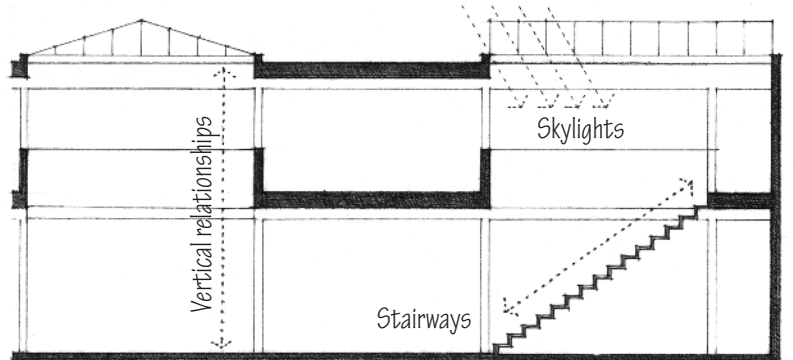
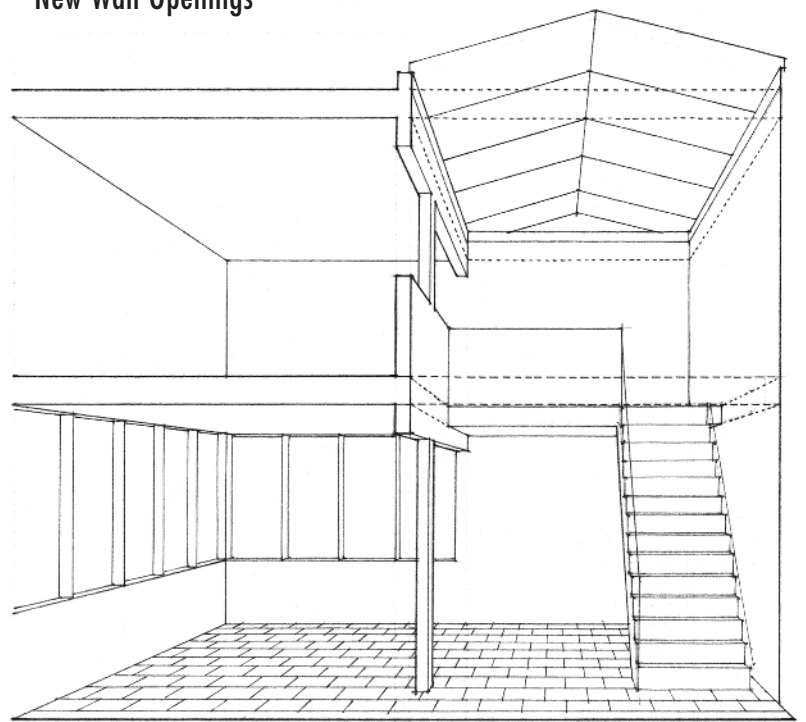

Vertical Expansion

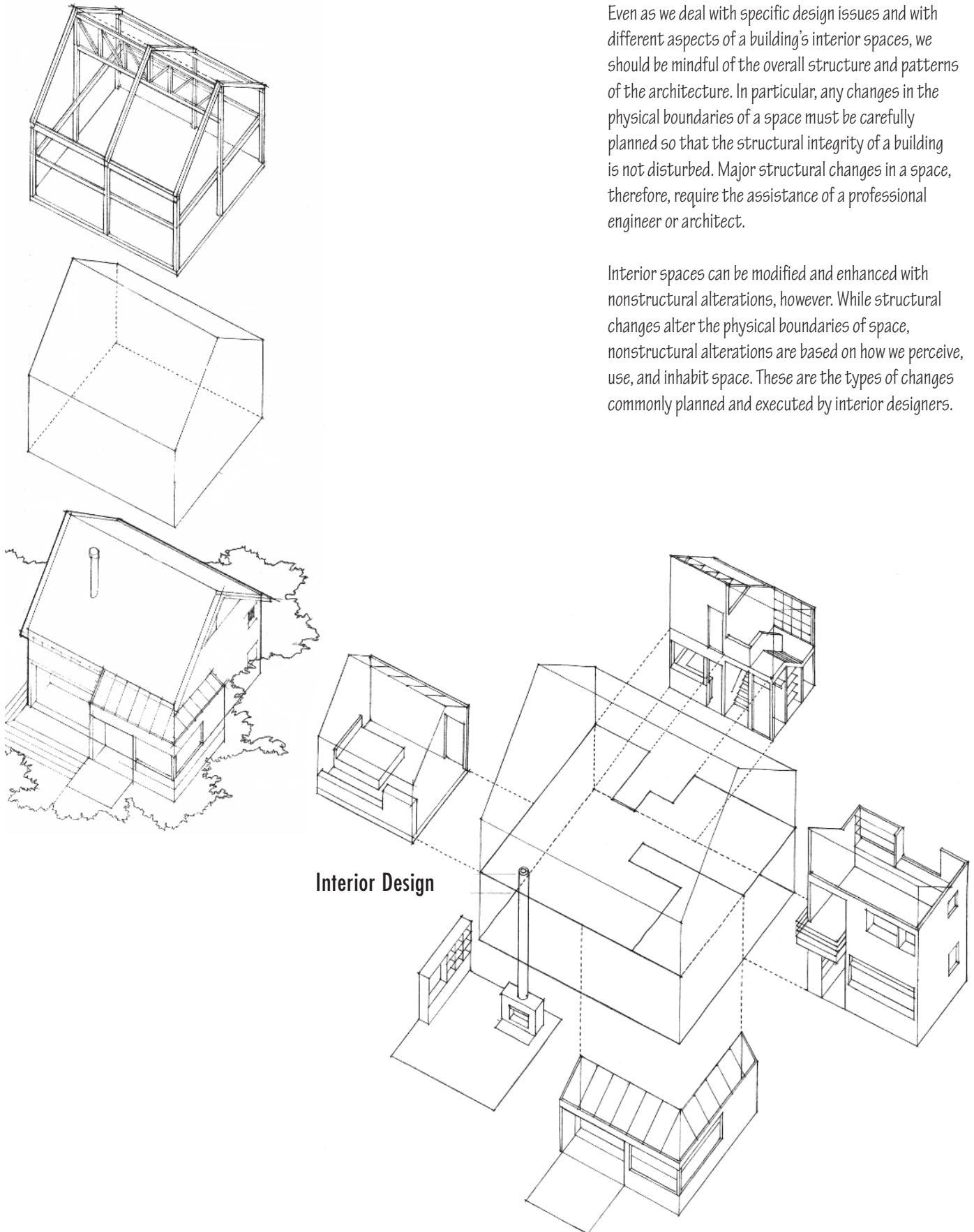

Even as we deal with specific design issues and with different aspects of a building's interior spaces, we should be mindful of the overall structure and patterns of the architecture. In particular, any changes in the physical boundaries of a space must be carefully planned so that the structural integrity of a building is not disturbed. Major structural changes in a space, therefore, require the assistance of a professional engineer or architect.

Interior spaces can be modified and enhanced with nonstructural alterations, however. While structural changes alter the physical boundaries of space, nonstructural alterations are based on how we perceive, use, and inhabit space. These are the types of changes commonly planned and executed by interior designers.